

Hollywood Racks Sport Rider Hitch Rack Instruction Manual

Model HR1000 (2013 edition) - 2 Bike Capacity, fits both 1 1/4" or 2" hitch receiver

Not to be used on any trailer, fifth wheel or towed vehicle

Weight Limit 45 lbs/20 kg per bike

Tools Required: Adjustable wrench and Phillips or flat screwdriver

Wrenches recommended: 3/4" or 19mm and 1/2" or 13mm

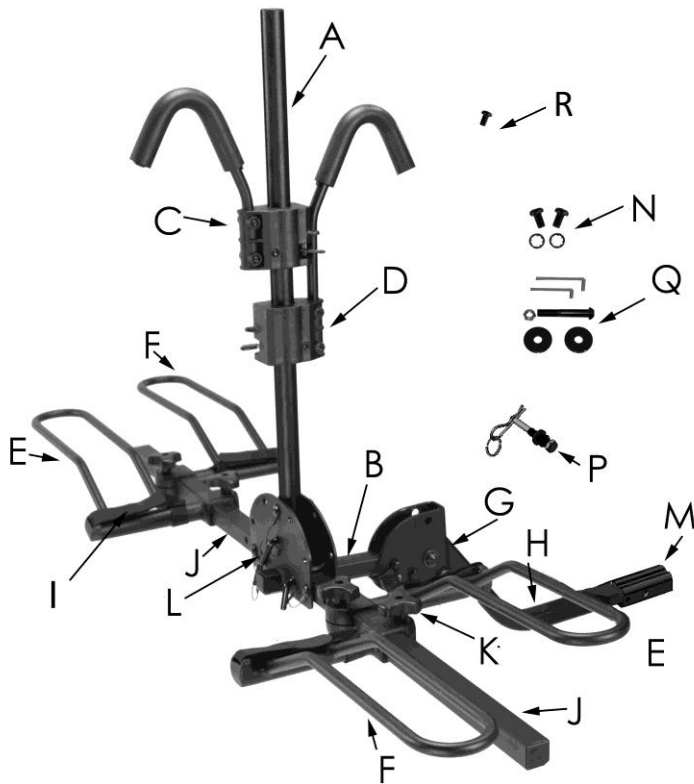

PARTS LIST

Item	Description	Qty
A	vertical post	1
B	support beam	1
C	short hook clamp	1
D	long hook clamp	1
E	left wheel holder	2
F	right wheel holder	2
G	folding bracket	1
H	hitch receiver tube	1
I	Velcro wheel straps	4
J	wheel tubes	2
K	knob for wheel holder	4
L	L-Pin	3
M	1 1/4"-2" adapter	1
N	wheel tube stop screws	2
P	Hitch bolt hardware kit:	
	Hitch pin bolt	1
	Flat washer	1
	Lock washer	1
	R shaped clip	1
Q	Hardware bag including:	
	1/2" diameter bolt	1
	Nut	1
	Washers	2
	Hex wrenches	2
	(8mm & 5mm)	
R	Vertical post stop screw	1

Assembly:

Tools required: adjustable wrench or equivalent (3/4" or 19mm and 1/2" or 13mm) 8mm Hex wrench included.

The SportRider 2 is easily assembled in just minutes. Place the rack on a table or flat surface with both the support beam (B) and receiver tube (H) lying on their sides (Fig. 1). Slide the receiver tube's bracket (G) onto the support beam. Align the outer holes and install the attached snapper pin and clip. Next, align the inner holes and install the 1/2" bolt and washer (Q). Rotate the rack upright, and install the nut and washer onto the bolt. Tighten nut and bolt securely. Next refer to **Fig. 3**: Adjust tightness on indicated nut using adjustable wrench (or either 1/2" or 13mm) so that the support beam fits snug inside the folding bracket. Do not over tighten or the fold up feature will be difficult to use.

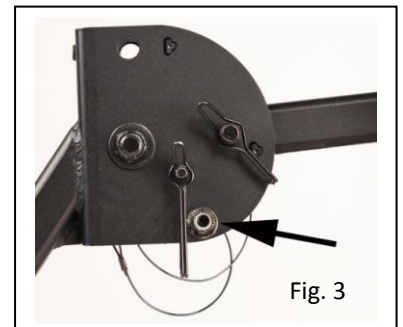
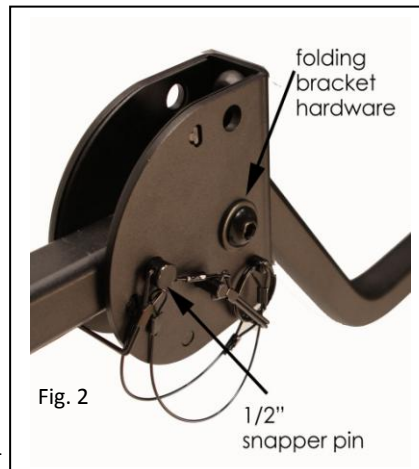
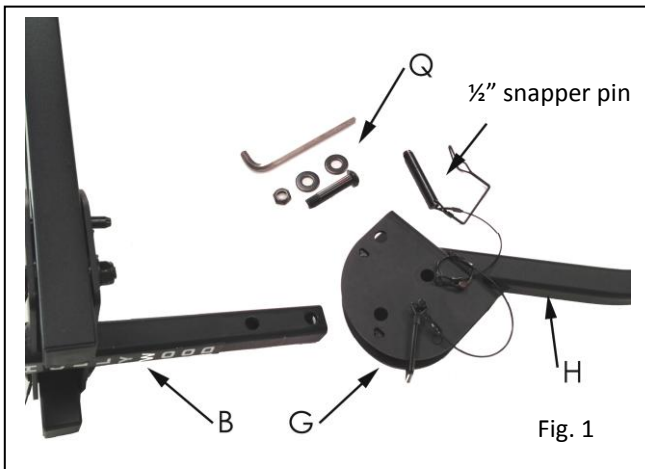

Installation into the hitch

Insert the receiver tube into the hitch and align the holes. Thread and tighten the bolt securely through the hitch and receiver tube using a wrench (adjustable, $\frac{3}{4}$ " or 19mm) then insert the safety clip. The rack should now be solidly mounted to your hitch. *Note for 2" hitches: When inserting the hitch pin bolt, the bolt should pass through the aluminum spacer first then through the receiver tube per Fig. 6.*

Use with 1 $\frac{1}{4}$ " hitches:
If the rack is to be used on a 1 $\frac{1}{4}$ " hitch, remove the aluminum spacer block from the receiver tube with the included 5mm hex wrench.

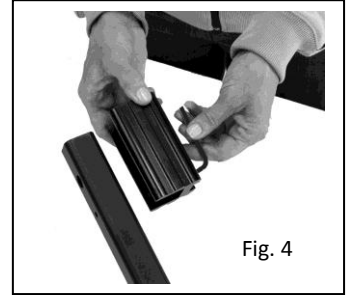

Fig. 4

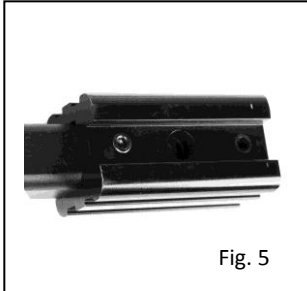

Fig. 5

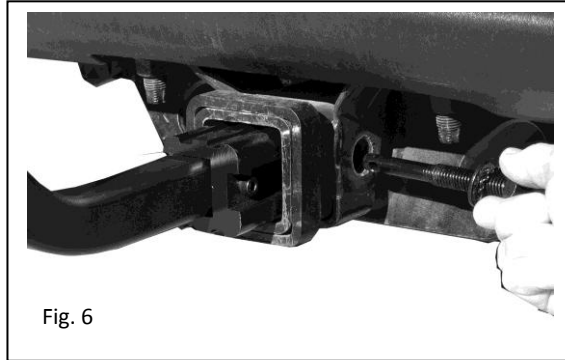

Fig. 6

Install Wheel Holders

See Fig. 7. Rotate and remove L pins from holes **AA** located on the rack's front plates. Rotate wheel tubes to a horizontal position, then replace L pins into holes **BB** as indicated. Select the smaller of the two bikes and position it in front of the rack, handle bars on the driver's side. The lowest point of the bike's top tube should be approximately even with the vertical post. Slide the wheel holders so they are aligned with the bike's wheels. Repeat for the second bike with the second set of wheel holders. Next, slide wheel Holders **E** and **F** onto wheel tubes as indicated. Note: They are snug – you may need to tap them on. *The wheel tube stop screws (N) should be installed after the bikes have been installed.*

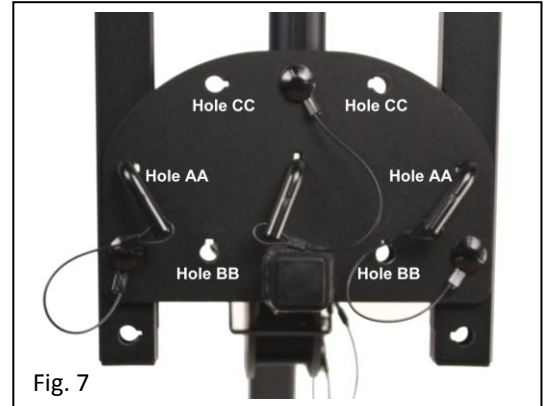

Fig. 7



Fig. 8

Installing the frame clamps

Position the long frame hook on top of the round vertical post facing the vehicle. Squeeze the lever and the tab together, so that the lever is all the way up (engaged). Now wiggle the plastic housing down onto the tube aligning the index guides with the index slots per Fig. 9. You may have to gently tap it with your other hand. Remember the lever must be engaged to install it onto the tube. Repeat for the short hook facing in the opposite direction.

Using the clamps: Once the clamp is installed, it can only be raised by engaging the lever. It is strongly recommended that the lever be engaged while pushing the plastic housing down to lower the clamp. *Tip: Push down on the plastic housing, not the metal hook.* **Install Vertical post stop screw per Fig. 10.** Use Phillips screwdriver.

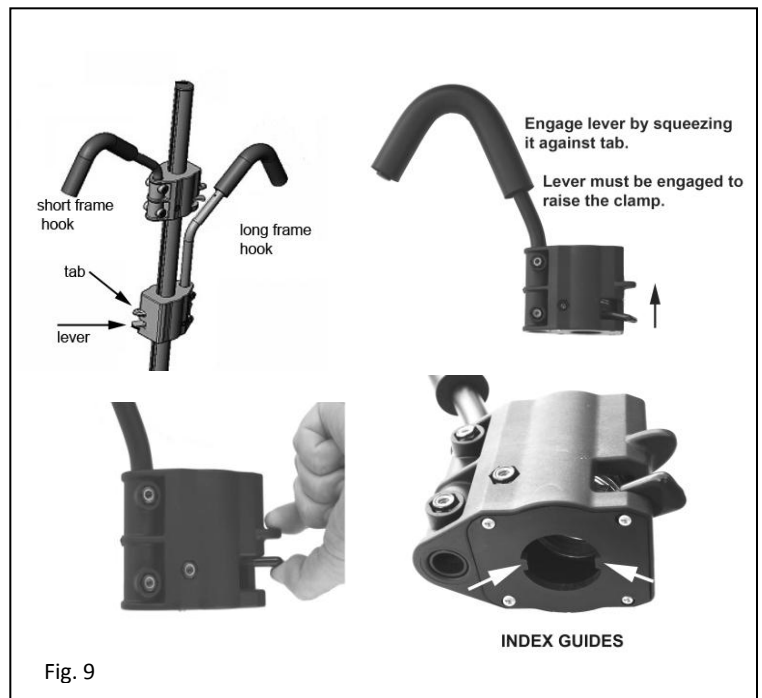
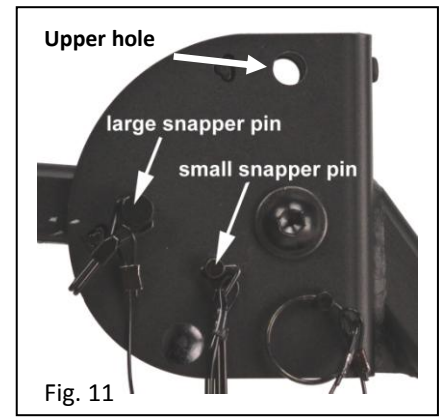
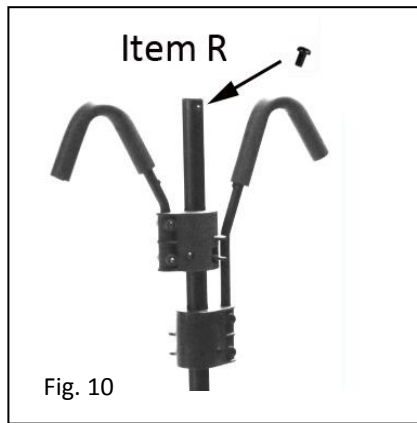

Fig. 9

Folding up when rack is mounted on vehicle (Fig. 12)

Rotate and remove the center L-Pin (L) per Fig. 7, then rotate the vertical post down and replace the L-pin in either holes CC. Next, refer to Fig. 11: Remove the ½" snapper pin, rotate support beam upwards then re-attach snapper pin into the upper hole.



Folding up for garage storage (Fig. 13):

Refer to Fig. 7: Remove L-pins from holes BB, rotate wheel tubes up and reinsert pins into holes AA.

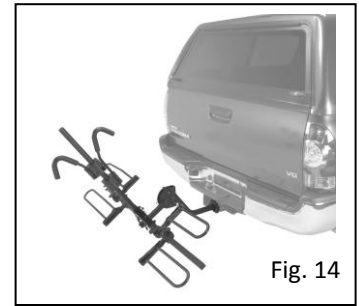
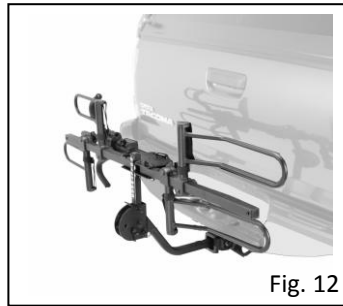

Tilting down for vehicle cargo area access (Fig. 14):

Remove the ½" snapper pin (Fig. 11). Next, remove smaller snapper pin and gently lower the support beam while holding rack up.

Installing bikes on the rack

The bikes should always be positioned so that the lowest point on the bike frame's top tube is close to the vertical post. The bike handlebars should be staggered (inside bike's handlebars on driver's side, outside bike's handlebars on passenger side).

While engaging the lever, lower the hook gently down onto bike frame as shown in Fig. 15.

To adjust the bike's wheel holders, loosen the knobs and slide wheel holders along the wheel support tube so that they are positioned directly beneath each wheel. Try to adjust the position of the wheel holder so that the hook will rest on the bike's lowest point of the top tube. Tighten knobs securely. Slide the hook down onto the frame. Use the Velcro strap (I) on the wheel holder per Fig. 16.

After the bike is mounted and the wheel holders tightened into the correct position, firmly push the clamps down on the bike's frame until fully engaged. *Push down on the plastic housing, not the metal hook.*

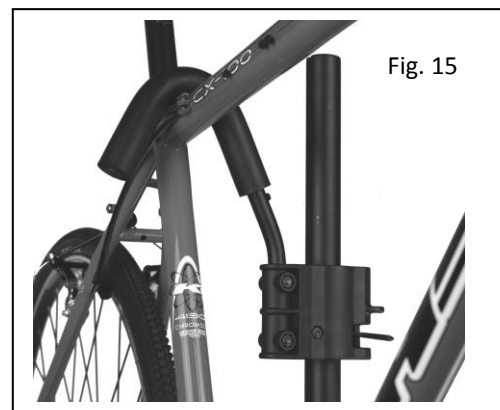

Installing wheel tube stop screws (N): After determining the final position of the wheel holders, install the stop screws (N) and washers into the bottom of the wheel tubes as indicated in Fig. 17. Use Phillips screwdriver.

Tips for carrying woman's bikes and bikes with slanted top tubes: Adjust the wheel trays so that the hook will rest in the bike frame's lowest possible point on the top tube. For very low top tubes, Please use the Bike Adapter Pro (sold separately).

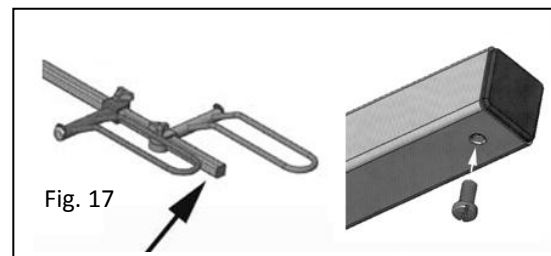

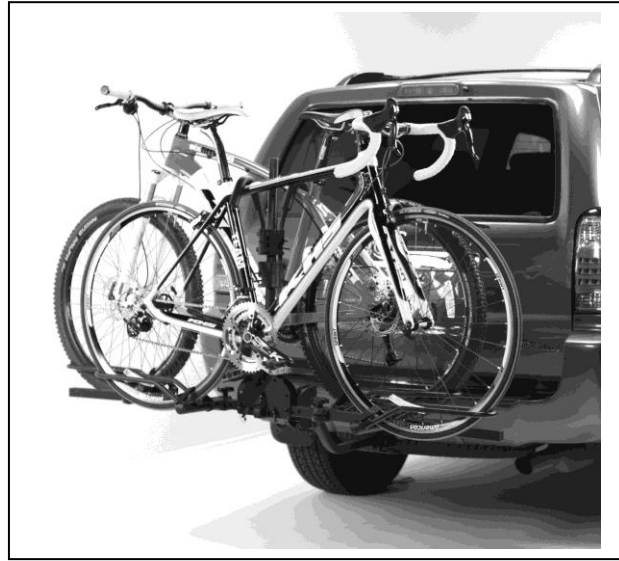

Double check before driving off:

- **Knobs are tight on all four wheel holders**
- **Frame hooks are firmly pressed down onto bike frames.**
- **Velcro straps are securely fastened**
- **Hitch pin is secure and hitch pin clip is installed**

Drive slowly on bumpy or dirt roads - Weight limit 45lbs/20Kg per bike

This product is not to be used on any trailer, fifth wheel or towed vehicle

Limited Lifetime Warranty (effective January 1, 2008):

Hollywood Racks will warrant its car racks and accessories during the time that an original retail purchaser owns the product subject to the exclusions and limitations of this warranty. Hollywood Racks will remedy defects in materials and workmanship by repairing or replacing (at its option) a defective part without charge for labor or parts. Hollywood Racks may elect (at its option) to issue a refund equal to the purchase price paid for the product.

This warranty does not cover problems caused by normal wear and tear including (but not limited to) weather, scratches, dents, rust, accidents, unlawful vehicle operation, misuse, abuse, neglect, theft, unauthorized modifications, or unauthorized repair. No warranty is given for defects resulting in incorrect assembly, incorrect installation onto the vehicle, installation on a "no fit" vehicle, incorrect attachment of bicycles onto the rack, or overloading of the rack's weight restrictions. This warranty terminates if the original retail purchaser transfers the product to any other person.

If a product is believed to be defective, the original retail purchaser should contact either the original retailer or Hollywood Racks directly at 800-747-4085 or at info@hollywoodracks.com

Disclaimer of Liability: Repair or replacement of a defective product or the issuance of a refund or credit (as determined by Hollywood Racks) is a purchaser's exclusive remedy under this warranty. Damage to a purchaser's vehicle, cargo, bicycles and or to any other person is excluded. This warranty is expressly made in lieu of any and all other express warranties, whether oral or written.

Hollywood Racks shall not be liable for any direct, indirect, consequential, incidental, special, punitive or any other damages in connection with the purchase, use or handling of this product.

Some states do not allow the exclusion or limitation of consequential or incidental damages and the above limitation may not apply to you. This warranty gives you specific legal rights and you have other rights, which vary from state to state.

Hollywood Racks
12812 South Spring Street Los Angeles, CA 90061
(800) 747-4085 (310) 516-8600 Fax (310) 516-8955
Customer Service Hours: 8:00 AM- 3:00 PM Pacific Time M-F
www.hollywoodracks.com info@hollywoodracks.com

12-2013 V4.1