

Assembly and Installation instructions Model # HR520 2" class 3 hitch req'd

WARNING! THIS PRODUCT IS NOT TO BE USED ON ANY TRAILER

PLEASE FOLLOW THESE IMPORTANT POINTS:

- DRIVE SLOWLY WHEN USING THE RACK ON BUMPY OR DIRT ROADS.
- CHECK THE RACK, BIKES AND STRAPS REGULARLY DURING USE.
- IF YOU HAVE ANY QUESTIONS OR INSTALLATION PROBLEMS, PLEASE SEE YOUR RETAILER OR CONTACT US AT 800 – 747- 4085.

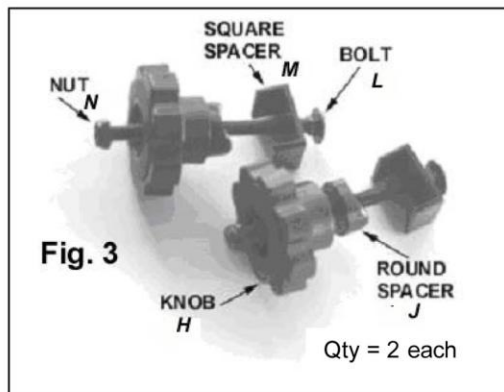
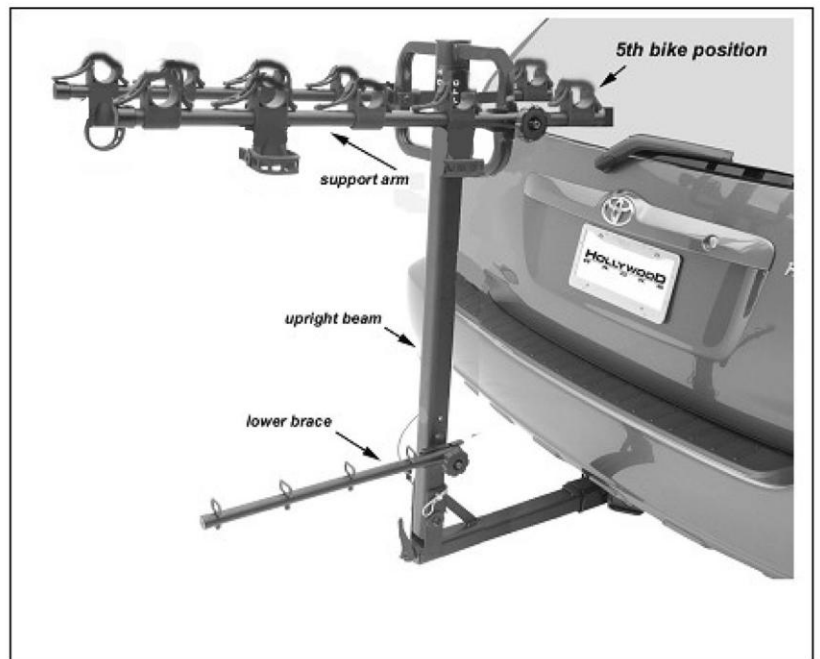

Fig. 1

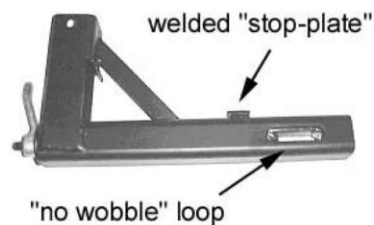

Fig. 5

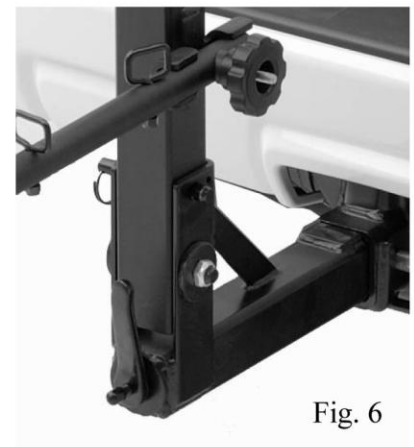

Fig. 6

After opening the box, you should have the following parts:

- Upright beam assembly (Fig 1) with wheel brace installed
- Two Support Arms (see Fig. 1)
- Parts bag including ½" diameter bolt, washers and nut, lynch pin and clip (Fig. 2: A, B, C, D).
- Locking hitch pin with security cable (Fig. 2: F & G)
- Support arm hardware bag including knob, plastic spacers and hardware (Fig. 3)
- Strap bag (Fig. 4) including 5 woven tie down straps and 15 rubber straps).
- Receiver tube assembly with "no wobble" system & handle lever (Fig. 5).

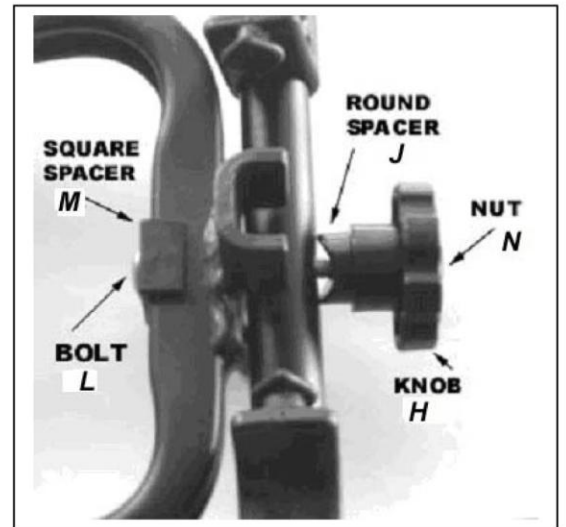

Fig. 7

ASSEMBLY

Tools required for assembly: Two 6" adjustable wrenches or equivalent, ½"/13mm socket

The Road Runner rack is easily assembled on your workbench or any flat surface. To assemble the rack, lay the upright beam face down on the bench (Hollywood decal facing down). Place the receiver tube's bracket on to the end of the upright beam so that the insert tube is pointing up.

1. Place a washer (B) on the end of the bolt (A), then insert the bolt through the **lower** hole of this bracket and pass it through the **lower** hole of the upright tube.. Once the bolt is protruding through the other side of the bracket, install the other washer (B) and nut (C). Tighten the nut securely on the bolt. Insert the attached lynch pin through the **upper** hole, and install lynch pin clip (D) in hole at the end of the lynch pin. See Fig. 5
2. To install the support arms: Locate parts bag with knob assembly (includes knob, carriage bolt, square spacer, round spacer and nut). Insert the bolt L through the square spacer M, then through the bike rack frame and support arm. Then install the round spacer J and knob H. Tighten knob, then install the nut N on the very end of the bolt so that the nut's nylon lock catches the bolt end. Repeat for other side. See Fig. 7 Note: Nut requires ½" or 13mm socket wrench for tightening.

INSTALLING THE RACK ON YOUR VEHICLE:

3. Within the parts bag, please locate the Locking Hitch Pin (F).
4. When inserting the rack into the trailer hitch, try to get the receiver tube as parallel to the hitch as possible. Slide the rack in a couple of inches until the welded "stop-plate" on the top of the receiver tube makes contact the outer face of your vehicle's hitch.
5. Unlock the Locking Hitch Pin and insert the long end through the trailer hitch **and** receiver tube. Be certain that the hitch pin goes through the "loop" at the end of the "no wobble" internal threaded rod. Failure to do so will render the "No Wobble" system inoperable. Be sure to install the lock onto the end of the Locking Hitch Pin. **Failure to do so will result in an accident.**
6. Tighten the lever clockwise to engage the patented "No Wobble" system, which will eliminate the movement of the insert tube in the receiver. **The lever should be turned "up" or to the side after tightening to prevent it from being damaged in the case you have to descend a steep driveway or have some other close encounter with "Solid Ground."** The rack should now be attached to your vehicle, and locked into place.

INSTALLING BIKES ON THE RACK:

7. Back off the knob on the rack's support arms, pull out the support arms and rotate them into the horizontal position. The arms should fit into the welded steel channels. Retighten the knobs securely. Rotate lower brace to its horizontal position.

8. Loosen knob on lower brace then rotate lower brace to its horizontal position. It should fit in the welded steel channel. Retighten black knob.



Fig. 8a



Fig. 8b



Fig. 8c

Attach one end of the rubber straps to the rubber cradles **13)**. Start with the round (end) hole of the strap stretched over the diamond shaped anchor on the cradle.

Place the **heaviest bike onto the rack first** (closest to the vehicle), putting the bike's top tube (usually) into the rubber cradles on the support arms. Be sure to note the location of the pedal, as you may have to rotate the crank in order to keep the pedal from hitting the vehicle.

Pull the rubber strap across the bike's frame tube and attach it to the anchor on the opposite side of the cradle for both right and left cradles. Straps should be snug, but *do not over-tighten* the straps since this may shorten the useful life of the strap.

Next, rotate the Anti-Sway cradle so that it rests against the bike's seat tube (this is the frame tube into which the seat post fits) Fig. 9c Pull the strap across the bike's seat tube in a similar snug manner.

Put the next bike on the rack with the handlebars on the other side of the vehicle and attach the straps. Be sure **not** to route straps over any cables but rather under them This will protect the bike's finish.

SPECIAL NOTES: On a bike with a slanted top tube, place top tube on rear cradle, and down tube on front cradle to keep bike as "level" as possible. For "ladies" style and non-conventional frames, it may not be possible to keep bike "level". On a road bike with a level top tube, place top tube on both cradles, with anti-sway on seat tube.

11. Using the lower brace anti-sway system (Fig. 9):

Using the 1" x 86" woven straps, run the strap through both front and rear wheels of each bike and then through the eyelet loop on the lower brace. Thread the end of the strap into the buckle and tighten the strap so that the bikes do not move. Repeat for the other bikes.



Fig. 9

12. Installing “wrap around tie down,” and security cable: After all the bikes have been installed, take the 86” tie down strap and wrap it around the rack’s upright tube and all of the bikes. There is not a lot of room, but **this is a very important safety step**. Tighten this strap securely.

13. Anti –Theft Security

For anti-theft security, the rack comes with a locking hitch pin and a 9-foot cable with an integrated lock. Wrap the cable around the bike frames, their wheels and through the rack. Secure by inserting end of cable in the lock.

14. REMOVING THE BIKES AND RACK

To remove the bikes, simply undo the straps and gently lift the bikes off. If you’re in a parking lot, be sure to fold down the support arms and fold up the wheel brace so as to minimize the length of the rack when not in use. To remove the rack from the vehicle, fold the support arms and lower brace, and remove the Locking Hitch Pin. Unscrew (counter-clockwise) the “no wobble” lever and slide the rack out of the hitch receiver.

15. BACKING OUT OF DRIVEWAYS AND GOING OVER BUMPS

Please keep in mind that when transporting bikes, you will be carrying more weight on your hitch. This means the rear of your vehicle will be lower to the ground. When going up driveways or over bumps, drive slowly and at an angle if possible. If you have a car or minivan where the hitch is low to the ground, the rack may hit the ground. Go slowly and please be sure the handle lever for the no wobble system is turned up or to the side.

Limited Lifetime Warranty (effective January 1, 2008):

Hollywood Racks will warrant its car racks and accessories during the time that an original retail purchaser owns the product subject to the exclusions and limitations of this warranty. Hollywood Racks will remedy defects in materials and workmanship by repairing or replacing (at its option) a defective part or the complete rack without charge for labor or parts. Hollywood Racks may elect (at its option) to issue a refund equal to the purchase price paid for the product.

This warranty does not cover problems caused by normal wear and tear including (but not limited to) weather, scratches, dents, rust, accidents, unlawful vehicle operation, misuse, abuse, neglect, theft, unauthorized modifications, or unauthorized repair. No warranty is given for defects resulting in incorrect assembly, incorrect installation onto the vehicle, installation on a “no fit” vehicle, incorrect attachment of bicycles onto the rack, or overloading of the rack’s weight restrictions. This warranty terminates if the original retail purchaser transfers the product to any other person. If a product is believed to be defective, the original retail purchaser should contact either the original retailer or Hollywood Racks directly at 800-747-4085 or at info@hollywoodracks.com

Disclaimer of Liability: Repair or replacement of a defective product or the issuance of a refund or credit (as determined by Hollywood Racks) is a purchaser’s exclusive remedy under this warranty. Damage to a purchaser’s vehicle, cargo, bicycles and or to any other person is excluded. This warranty is expressly made in lieu of any and all other express warranties, whether oral or written.

Hollywood Racks shall not be liable for any direct, indirect, consequential, incidental, special, punitive or any other damages in connection with the purchase, use or handling of this product.

Some states do not allow the exclusion or limitation of consequential or incidental damages and the above limitation may not apply to you. This warranty gives you specific legal rights and you have other rights, which vary from state to state.

Hollywood Racks

12812 S. Spring St. Los Angeles, CA 90061

(800) 747-4085 or (310) 516-8600 FAX (310) 516-8955 info@hollywoodracks.com

www.hollywoodracks.com

Customer Service: M-F 8:00 AM – 3:00 PM PST

Made in Taiwan

04-13 rev d