

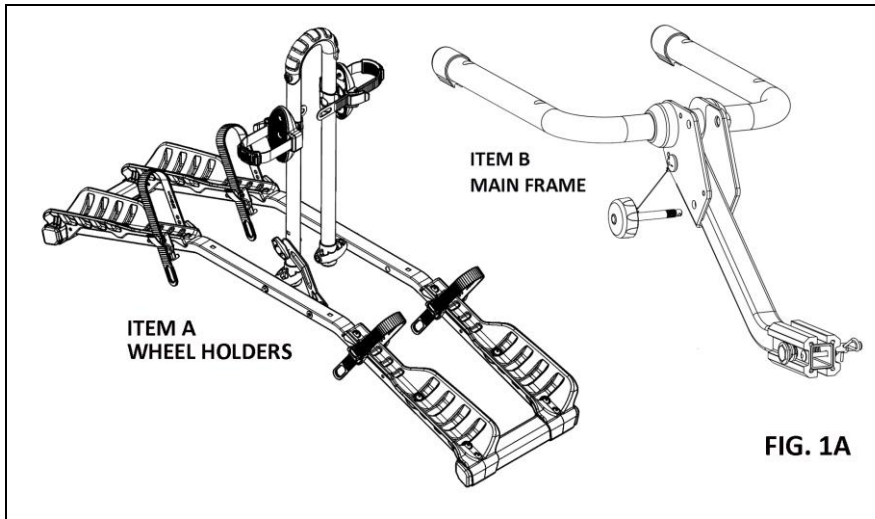

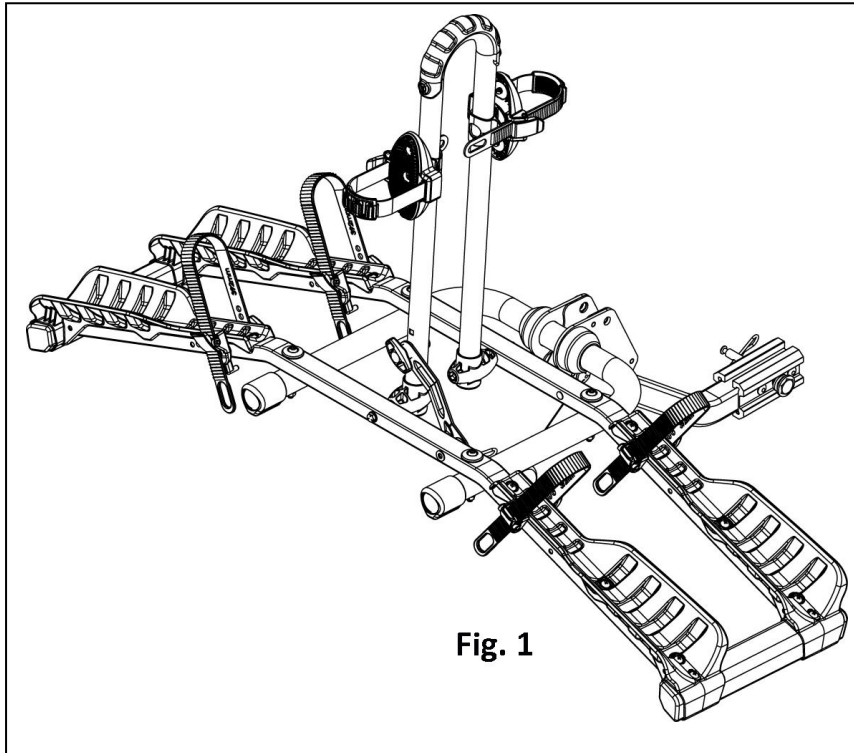





Hollywood Racks Destination 2 Hitch Rack *Assembly and Instruction Manual*

Model No. HR4200 Fits 1 1/4" & 2" hitches only - 2 bike capacity - Maximum weight 35 lbs/16kg per bike

- For use on 1 1/4" & 2" hitches. Do not use hitch extenders.
- Maximum weight 35lbs/16kg per bicycle. Do not use with Electric bicycles, motorized bicycles, mopeds or motorcycles
- This product is not intended for use on any trailer, fifth wheel or vehicle being towed by another vehicle.

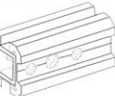
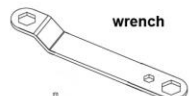
For video & installation instructions, please visit Hollywoodracks.com



Item	Quantity	Description
C	4x	 Ø6.5 mm washer
D	4x	 M6x62 mm bolt
E	4x	 Ø6.5 mm washer
F	4x	 M6x1.0 mm nut
G	1x	 adapter (NOTE: ADAPTER ATTACHED TO MAIN FRAME ITEM B)
H	1x	 wrench
I	1x	 screwdriver/hex key
J	1x	 1/2" flat washer for hitch pin
K	1x	 1/2" split washer for hitch pin
L	2x	 "R" shaped clip
M	1x	 1/2" -13 threaded hitch pin
N	1x	 hitch pin lock with 2 keys
O	1x	 tie down strap
P	1x	 socket wrench

Step 1: Assembly of bike rack

Assembly Tools Required:



Parts Required:

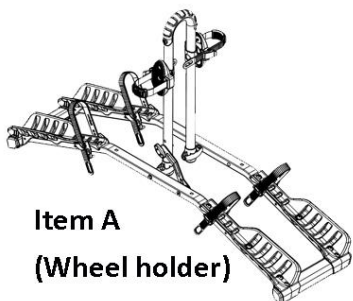

Item A
(Wheel holder)

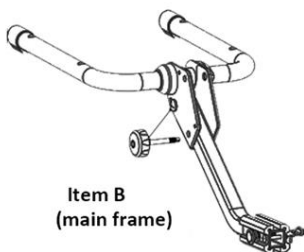

Item B
(main frame)



Item L x1



Ø6.5 mm x 4
Item C



M6x62 mm
Item D x 4



Ø6.5 mm
Item E x 4



M6x1.0 mm
Item F x 4

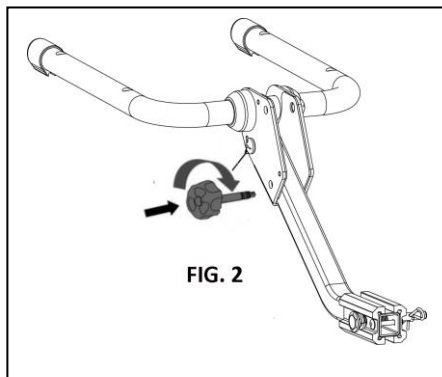

FIG. 2

Install knob into bracket per Fig. 2

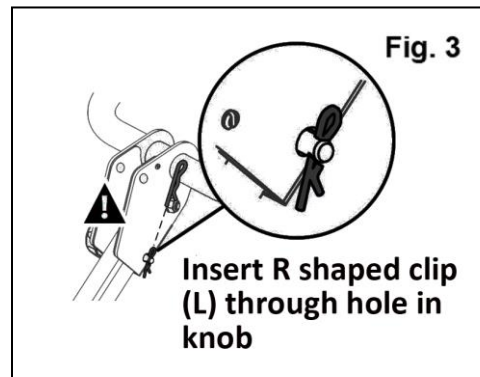

Fig. 3

Insert R shaped clip (L) through hole in knob

Insert Clip L through hole in knob

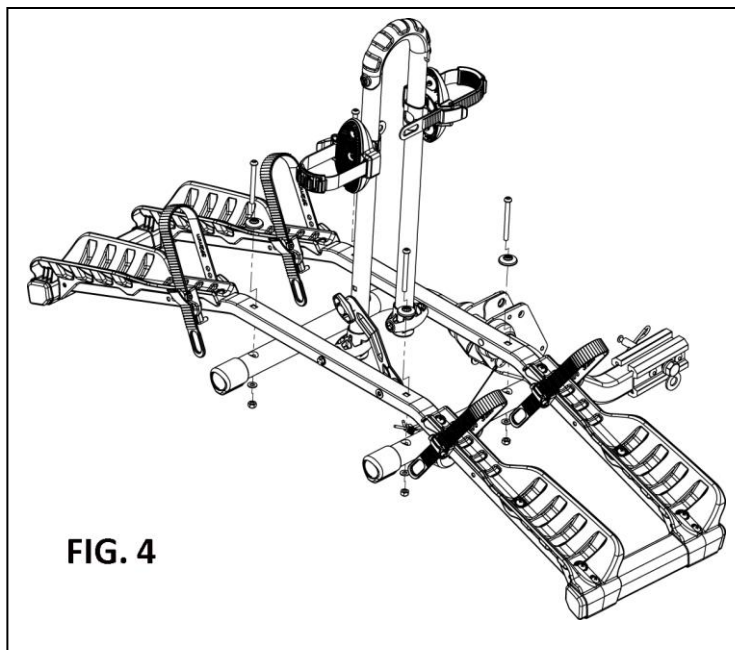

FIG. 4

Place the wheel holder on top of the main frame per Fig. 4. Align the holes (*There are four bolt/washer/nuts per wheel holder*). Assemble washer C through bolt D, then insert the bolt/washer through the aligned holes of the wheel holder and frame. Install washer E and tighten nut F onto bolt. Repeat for the other **three** bolts. After all four bolts and nuts have been installed, use the provided tools to tighten all four nuts and bolts securely per Fig. 5

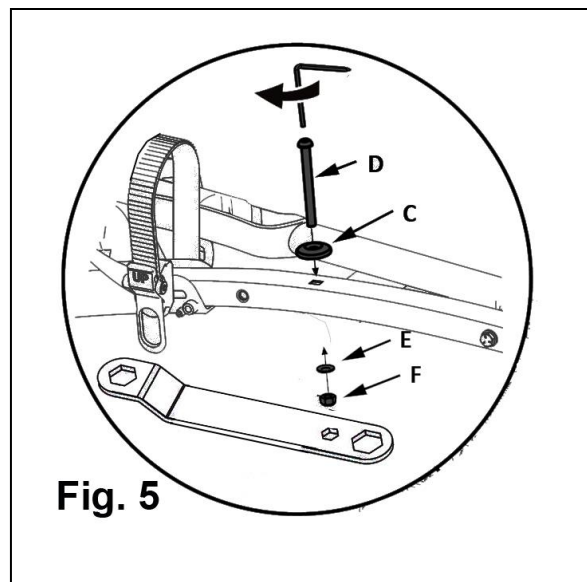

Fig. 5

Step 2: Installing rack into 1 1/4" or 2" trailer hitch

Assembly Tools Required:



Item I



Item P
(for 1 1/4" hitches only)

Parts Required:

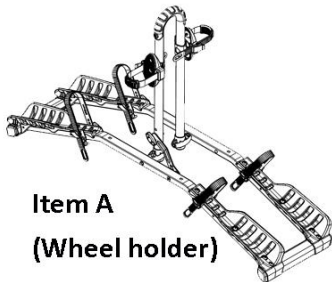

Item A
(Wheel holder)

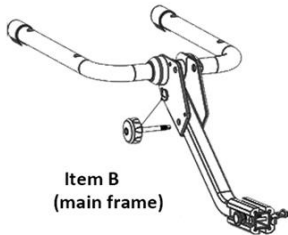

Item B
(main frame)



Item L X1



Ø6.5 mm x 4
Item C



M6x62 mm
Item D X 4



Ø6.5 mm
Item E X 4



M6x1.0 mm
Item F X 4

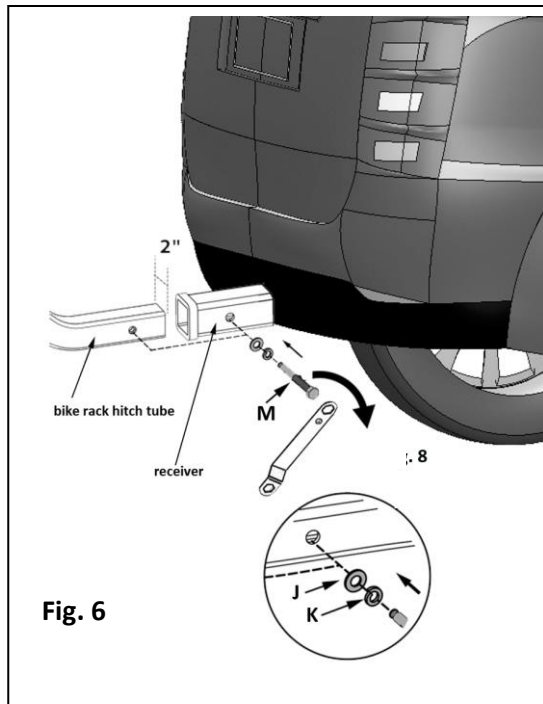

Fig. 6

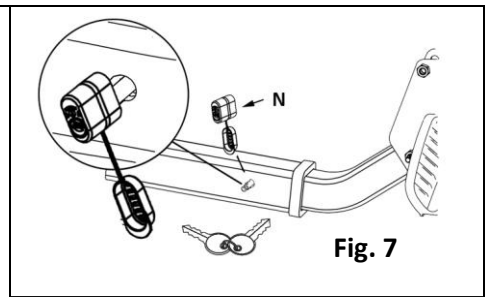

Fig. 7

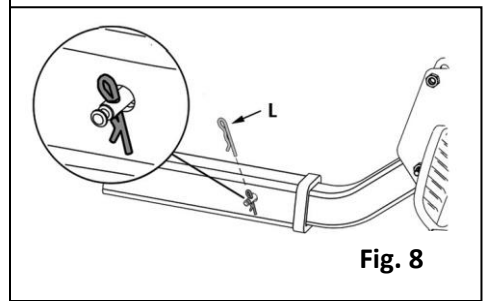

Fig. 8

Insert the bike rack's hitch tube into the vehicle's trailer hitch receiver. Align the holes of the hitch tube with the receiver. Place split washer K then the flat washer J onto hitch pin M per Fig. 6. Thread the hitch pin through the receiver and into the hitch tube using the tool provided. Alternatively, use a 3/4" or 19mm socket. Tighten securely. Place the lock onto the hitch pin's end, then lock it by turning the key per Fig. 7. Alternatively, the R shaped clip L can be installed through the hole in the hitch pin per Fig. 8.

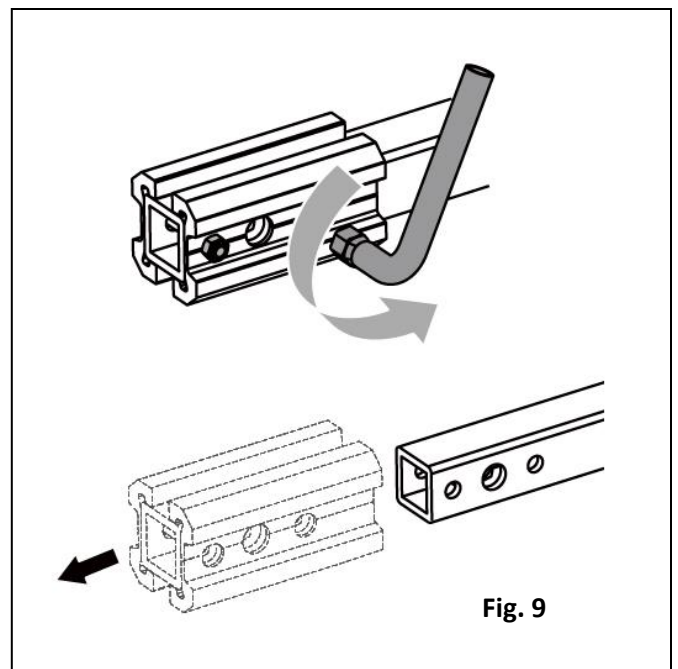

Fig. 9

Use with 1 1/4" hitches:

If the rack is to be used on a 1 1/4" hitch, remove the aluminum spacer block from the receiver tube with the included socket wrench (item P) per Fig. 9. Insert and tighten per above instructions.

Step 3: Setting up the rack

Install the rack into your vehicle's trailer hitch per the above section. Rotate the mast to the vertical position per Fig. 10.

Attach the slotted hinge to the bolt on the mast. Be sure the slot (Fig. 11) is firmly engaged on the bolt and tighten the knob securely. If the knob and bolt are missing or misplaced, do not use this product until an equivalent replacement has been installed on the rack.

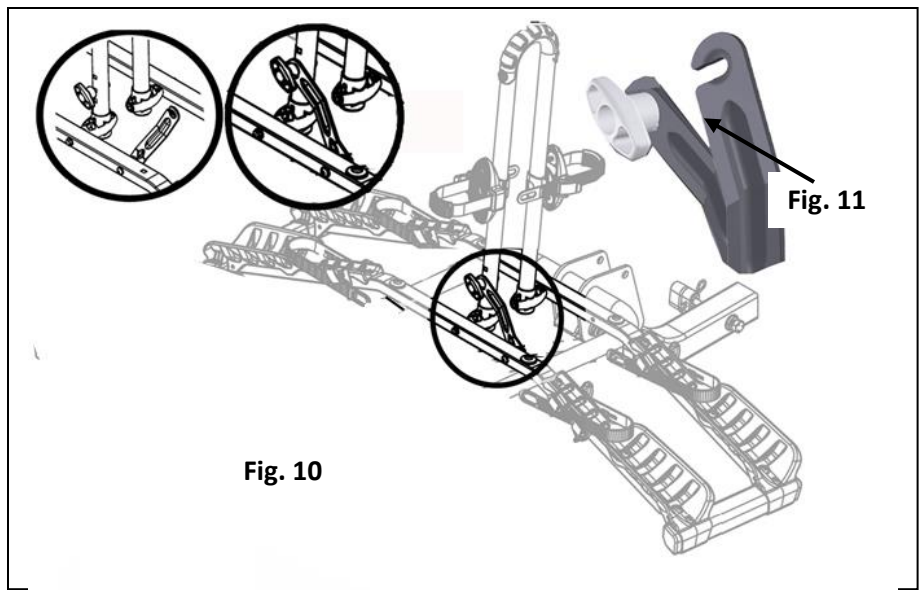

The Destination 2 rack features ratcheting wheel straps. If your bike's wheelbase is under 44", you may need to remove the ratchet straps and relocate them to the inner hole positions per Fig. 13 and 14 on page 4. The ratcheting straps may also need to be relocated depending on the mix of bikes, type of handlebars and height of seat.

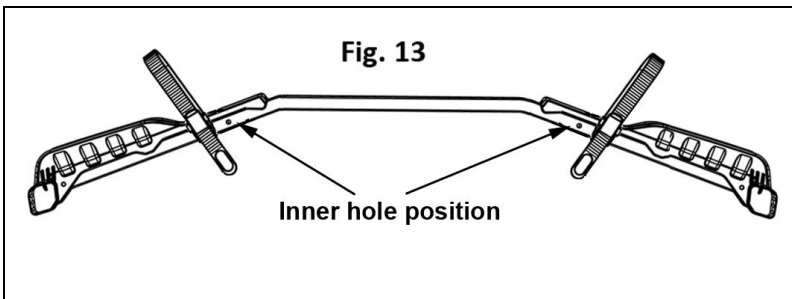
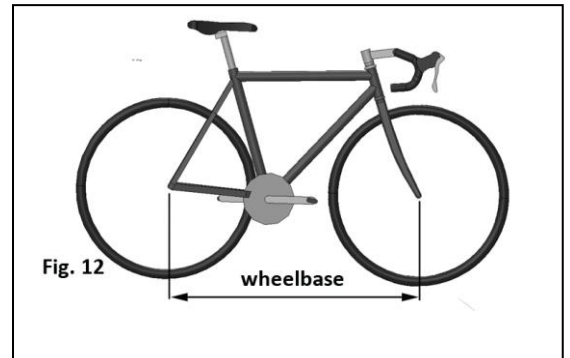

To remove strap and buckle, unscrew the knob and relocate the bolt with buckle to inner hole position. Re-install strap onto bolt and install the knob. Buckle opening must be on top when inserting strap. Tighten knob securely

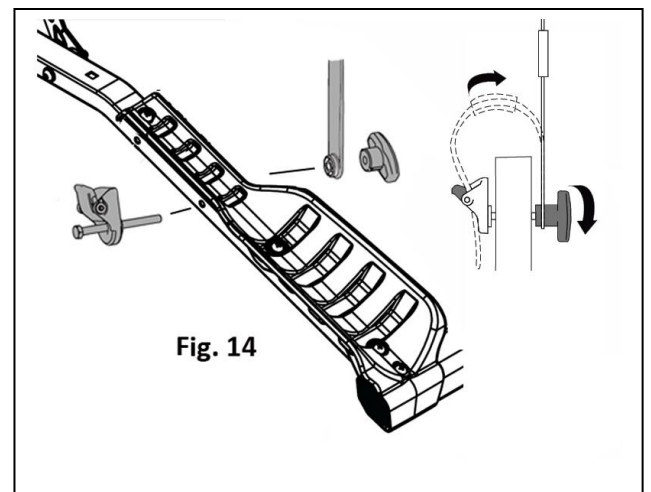

Step 4: Mounting and securing bikes

Please read this first: *Mounting bikes to the Destination 2 hitch rack is simple, but please follow these basic tips and guidelines:*

1. Always mount the largest bikes first.
2. The first and third bikes should have their handlebars on the driver side. The second and fourth or outside bike should have their handlebars on the passenger side. This is so the bike's chain rings will not be in contact with the vertical mast.

3. Location of the pedals make the bike's loading easier so there is little interference. We've supplied some tips, but all bikes have different geometry so look for what works best for your bikes.

4. You may have to raise or lower your seat posts for fitting the bikes on the rack.

5. Depending on your bike's wheelbase, you may need to relocate one or both wheel ratchet straps to the inner hole. You may have to relocate a wheel ratchet strap depending on the geometry of the adjacent bikes.

If any questions or comments, please contact us at info@hollywoodracks.com

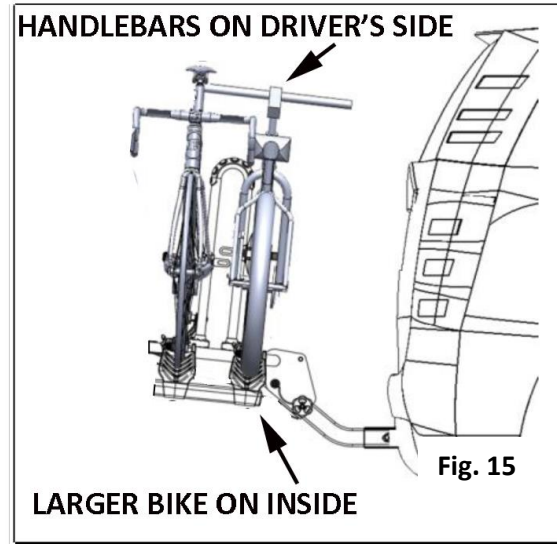

Mounting and securing the first bike: Place the bike (handlebars on driver side) onto the inner most wheel tray per Fig. 17. Rotate the frame ratchet strap (Fig. 18) so that it aligns with the bike's frame. Insert the strap into the top of the buckle and pull the strap tight per Fig. 19.

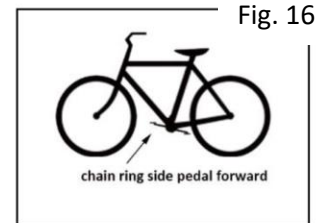
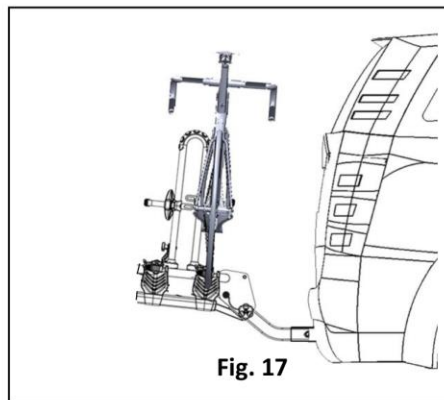

First Bike Installation Tip: rotate pedals so that right (or chain ring side) is forward.

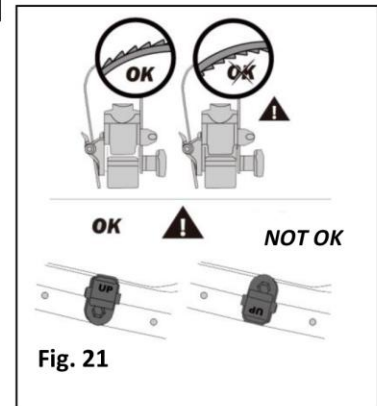
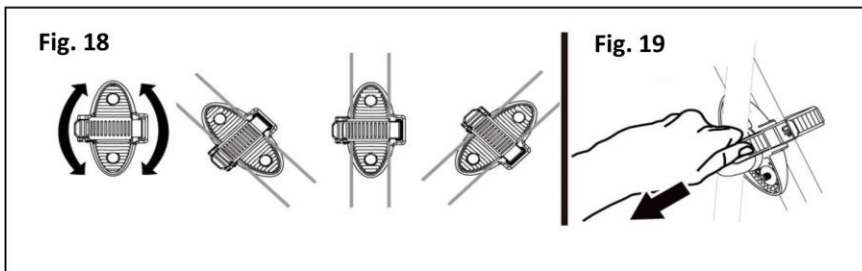

Attach the wheel ratchet straps to the bike's wheels per Fig. 20. Note position of strap and wheel. If you need to relocate the wheel strap to the outer hole position, please refer to Fig. 14 on page 4. Note Fig. 21 for correct position of buckle and ratchet teeth.

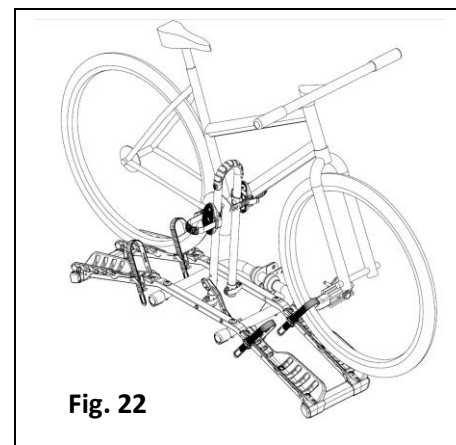
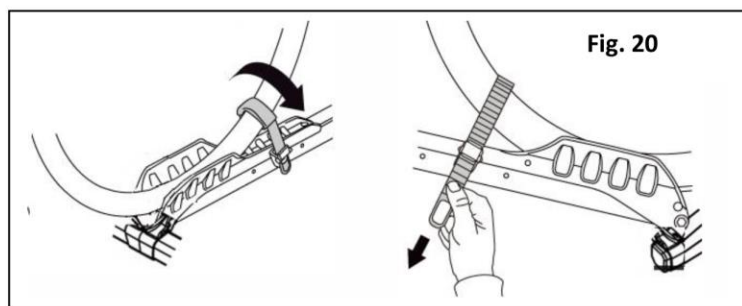

Mounting and securing the second bike:

Place the bike onto the wheel trays (handlebars on passenger side) per Fig. 23.



Rotate the frame ratchet strap (Fig. 18) so that it aligns with the bike's frame. Insert the strap into the top of the buckle and pull the strap tight per Fig. 19.

Attach the wheel ratchet straps to the bike's wheels per Fig. 20. Note position of strap and wheel. If you need to relocate the wheel strap to the outer hole position, please refer to Fig. 13 and 14. Note Fig. 21 for correct position of buckle and ratchet teeth.

Second Bike Installation tip:
Rotate pedals so that the right pedal is up.

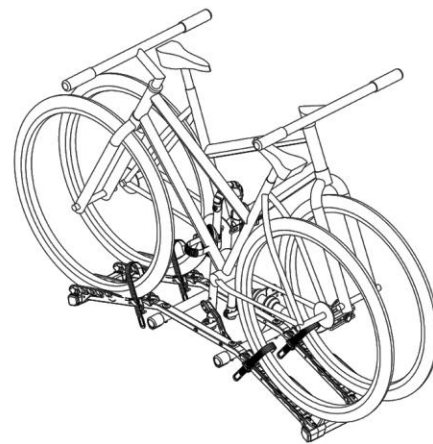
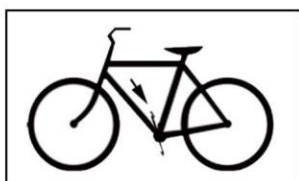

Step 5: Attaching Safety Tie Down Straps

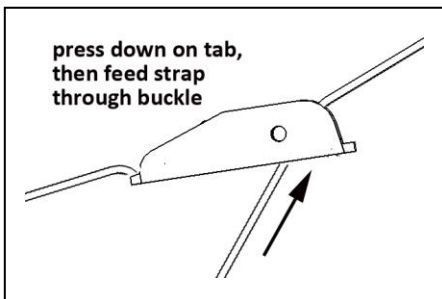

Included with the Destination 2 rack is a red tie down strap (item O). Per Fig. 24, attach the straps to the bike frames and masts. Insert the end of the strap into the buckle and pull securely. Straps should have no slack after installation.

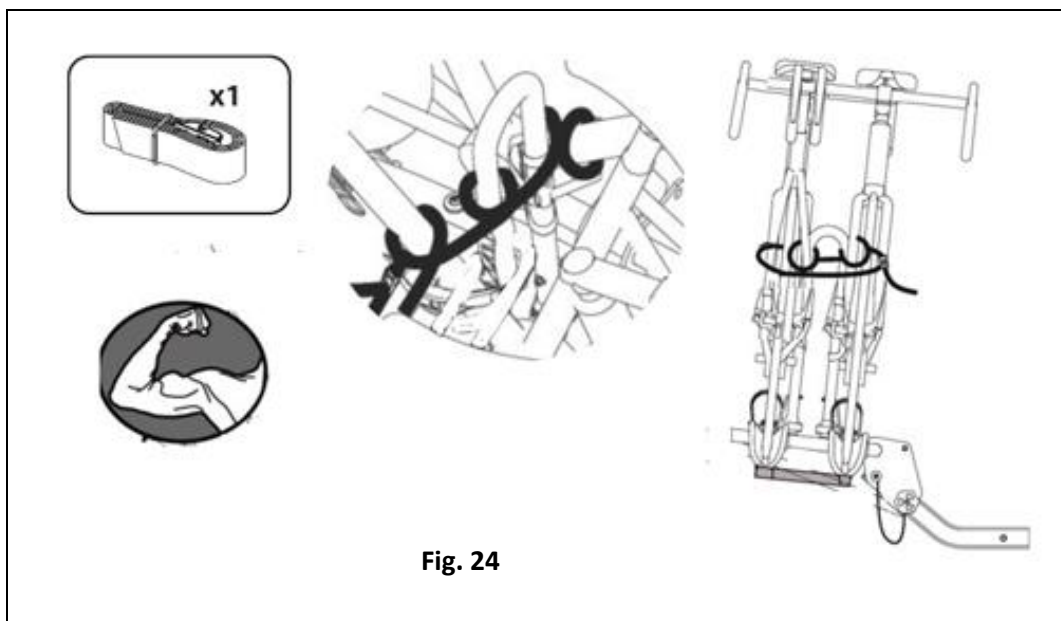

Fold Up Function

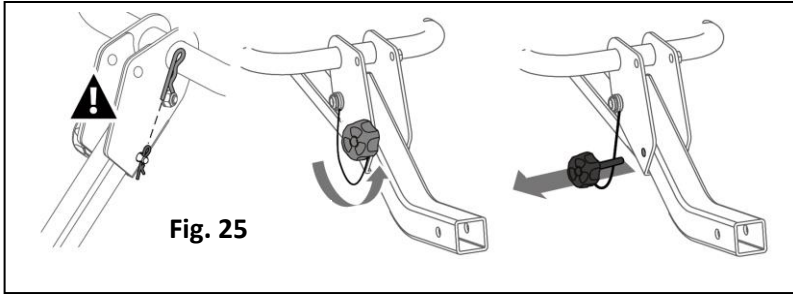

To fold the Destination 2 rack against the back of the car:

Fold down the masts >> Fasten one of the wheel ratchet straps around the mast to prevent it from moving when the rack is folded against the vehicle >> Remove clip from knob >> Unscrew knob >> Remove knob (Fig. 30)

Rotate the rack upwards >> insert and tighten knob >> Insert clip into hole in knob (Fig. 26-28)

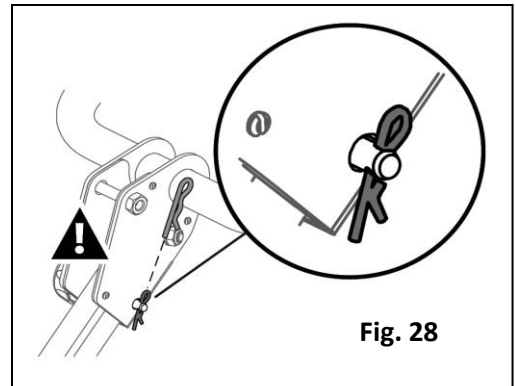
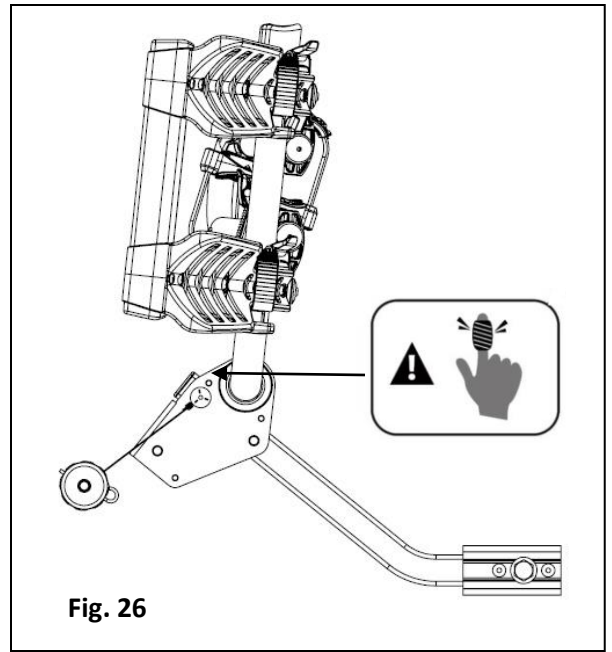
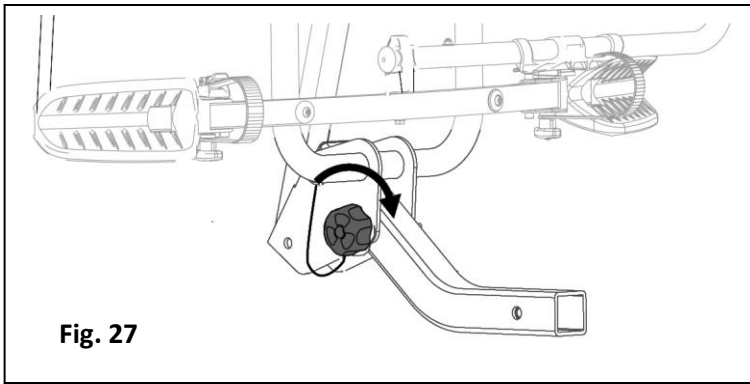

Rear Hatch/Door

To gain access to rear cargo area, fold down the masts per Figs. 29 and 30.

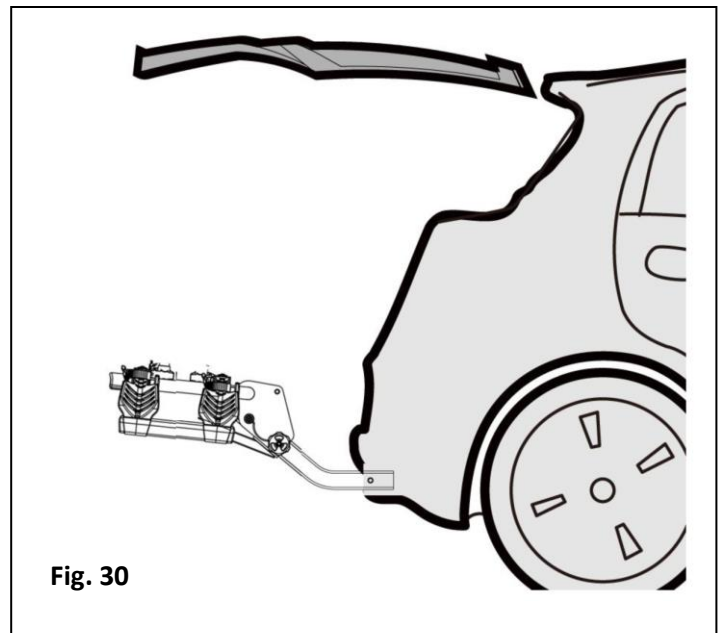
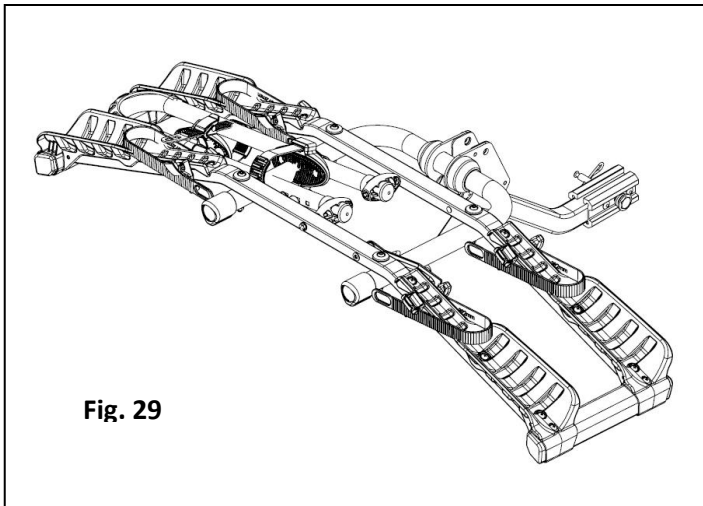

CAUTION: DO NOT EXCEED BIKE WEIGHT CAPACITY. THIS PRODUCT WILL NOT SUPPORT E-BIKES.

Double check before driving:

1. Slotted hinges are fully engaged & knobs are securely fastened
2. Frame and wheel ratchet straps are tight and securely fastened
3. Safety tie-down straps are securely fastened around bikes and masts
4. Hitch pin & lock head are installed and secure

Drive slowly on bumpy or dirt roads.

This product not to be used on any trailer, fifth wheel or towed vehicle



Optional 8'
security cable sold
separately.

Cable locks
wheels and
frames to locking
hitch pin

Limited Lifetime Warranty (effective January 1, 2008):

Hollywood Racks will warrant its car racks and accessories during the time that an original retail purchaser owns the product subject to the exclusions and limitations of this warranty. Hollywood Racks will remedy defects in materials and workmanship by repairing or replacing (at its option) a defective part without charge for labor or parts. Hollywood Racks may elect (at its option) to issue a refund equal to the purchase price paid for the product. This warranty does not cover problems caused by normal wear and tear including (but not limited to) weather, scratches, dents, rust, accidents, unlawful vehicle operation, misuse, abuse, neglect, theft, unauthorized modifications, or unauthorized repair. No warranty is given for defects resulting in incorrect assembly, incorrect installation onto the vehicle, installation on a "no fit" vehicle, incorrect attachment of bicycles onto the rack, or overloading of the rack's weight restrictions. This warranty terminates if the original retail purchaser transfers the product to any other person. If a product is believed to be defective, the original retail purchaser should contact either the original retailer or Hollywood Racks directly at 800-747-4085 or at info@hollywoodracks.com **Disclaimer of Liability:** Repair or replacement of a defective product or the issuance of a refund or credit (as determined by Hollywood Racks) is a purchaser's exclusive remedy under this warranty. Damage to a purchaser's vehicle, cargo, bicycles and or to any other person is excluded. This warranty is expressly made in lieu of any and all other express warranties, whether oral or written. Hollywood Racks shall not be liable for any direct, indirect, consequential, incidental, special, punitive or any other damages in connection with the purchase, use or handling of this product. Some states do not allow the exclusion or limitation of consequential or incidental damages and the above limitation may not apply to you. This warranty gives you specific legal rights and you have other rights, which vary from state to state.

Hollywood Racks

12812 South Spring Street Los Angeles, CA 90061 (800) 747-4085 (310) 516-8600 Fax (310) 516-8955
Customer Service Hours: 8:00 AM- 3:00 PM PST www.hollywoodracks.com info@hollywoodracks.com

Made in Taiwan

HR4200

11/19 V1