

# Hollywood Racks Assembly & installation instructions for model:

## HR1560Z-E (E bikes)

- For use on 1-1/4" hitches. 2" adapter included
- For use on CLASS 2 or CLASS 3 Hitch Receivers only (Never on Class 1)\*
- Maximum weight per bicycle is 80lbs
- Not intended for use with motorized bicycles, mopeds or motorcycles.
- Not intended for use on any trailer, fifth wheel or vehicle being towed by another vehicle.

\*Please check our website or call us for more information.

USE THE INSTRUCTIONS ON THIS SHEET FOR STEP 1 AND  
CONTINUE ASSEMBLY USING THE HR1500 INSTRUCTION SHEET  
FOLLOWING THIS PAGE

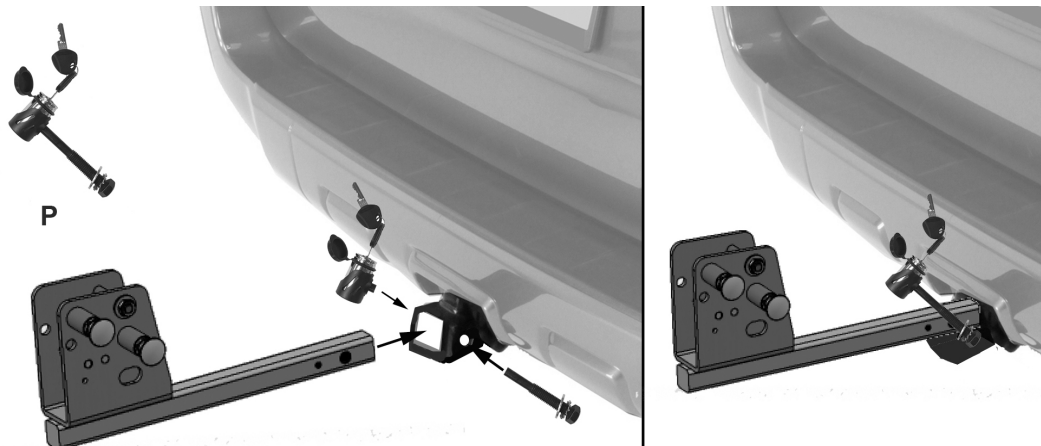

### Step 1: Install Hitch Tube (B) into vehicle's trailer hitch. Then install Hitch Tightener

Insert the receiver tube into the hitch and align the holes. Thread and tighten the bolt securely using a wrench (adjustable,  $\frac{3}{4}$ " or 19mm). If you intend on using the rack after assembly, then install the locking head onto the end of the hitch pin.

Flip this page for instructions on installing the hitch Tightener. Then proceed to step 2 using the HR1500 Instruction sheet attached.

**Tools Required: Adjustable wrench or 7/8" wrench**

**Contents:**

**U-Bolt for 2" hitches (qty = one)**

**U-Bolt for 1 1/4" hitches (qty = one)**

**Clamp Bar (qty = one)**

**Split Washers (qty = two)**

**Flat Washers (qty = two)**

**1/2-13 Hex Nuts (qty = four)**

**7/16-14 Hex Nuts (qty= four)**

**Note: This product requires a flange on your hitch**

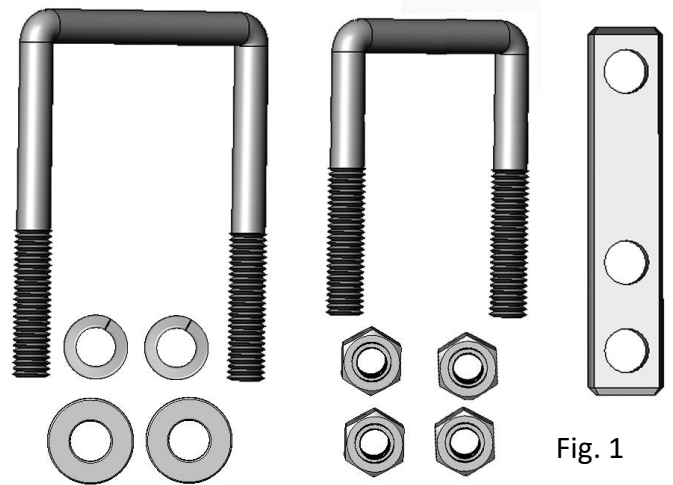

Fig. 1

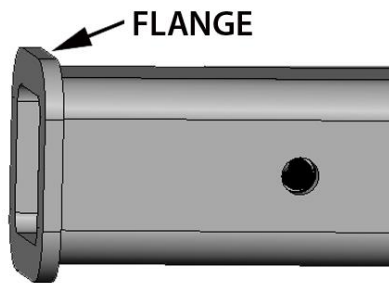

Fig. 2

1. Check the package contents per Fig. 1.
2. Per Fig. 2, please note that this product requires that your hitch has a flange.

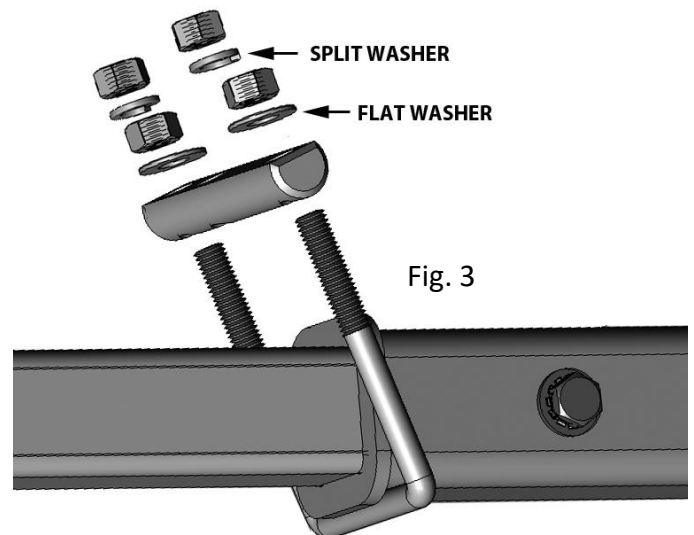

Fig. 3

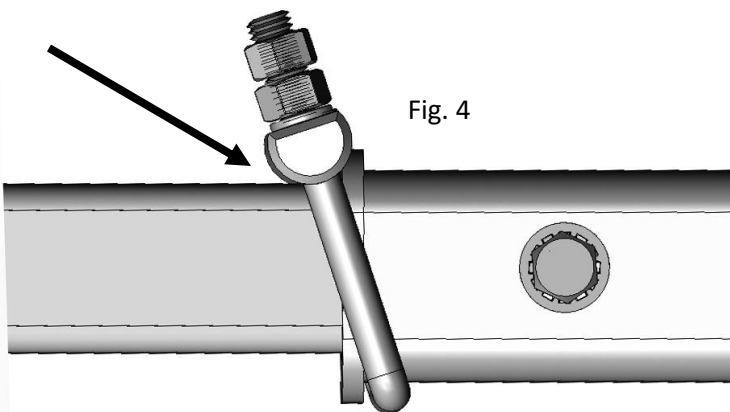

Fig. 4

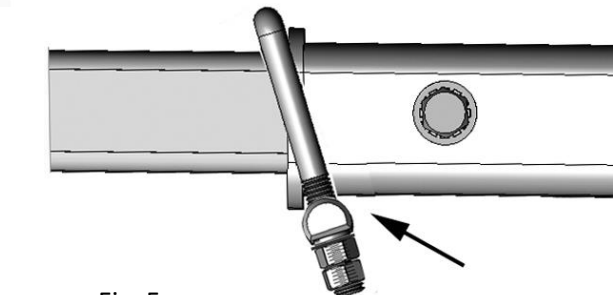

Fig. 5

*Note: The hitch tightener can be installed with the clamp bar below the hitch and behind the flange per Fig. 5.*

3. Place the U-bolt below the receiver hitch and behind the flange per Fig. 3.

4. Slide the clamp bar onto the legs of the U-bolt. Rounded surface of the clamp bar must in contact with the flange and accessory tube per Fig. 4.

5. Install the flat washers and thread a nut onto both legs of the U-bolt. Tighten the nuts securely so there is equal pressure on the clamp bar.







6. Install the split washers and thread the second set of nuts onto the legs of the U-bolt. Tighten securely, max. torque 25 ft-lbs.

# Hollywood Racks Sportrider Model HR1500 Hitch Mounted E-Bike Rack

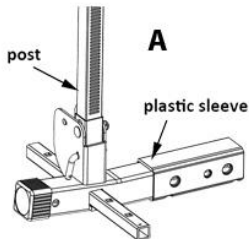
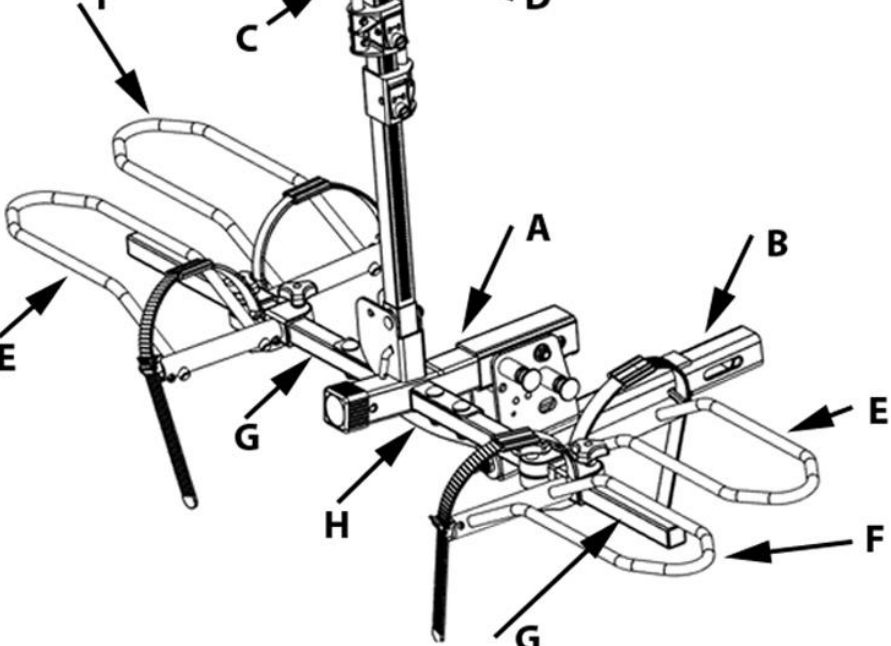
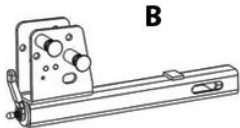
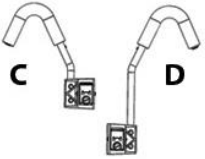
## Assembly and Installation Instructions

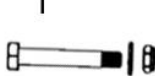
- Two bike capacity. For use on 2" hitches only. Do not use a 1 1/4" to 2" hitch adapter, bumper mount hitch adapter or hitch extenders. This product is not intended for off-road use.
- Maximum weight per bicycle = 80lbs. Maximum bicycle wheelbase = 60". Maximum tire width = 5".
- Do not use with mopeds, motorcycles, gas powered bicycles
- This product is NOT warranted for use on any trailer, 5<sup>th</sup> wheel or towed vehicle.
- For video and assembly & installation instructions, please visit [Hollywoodracks.com](http://Hollywoodracks.com)

### Parts

|   |  |  |  |
|---|--|--|--|
|  <p><b>A</b><br/>post<br/>plastic sleeve</p> | <p>main frame with post and plastic sleeve<br/>Qty = 1</p>                                       |   |  |
|  <p><b>B</b></p>                            | <p>hitch tube with no-wobble system<br/>Qty = 1</p>  |  |  |
|  <p><b>C</b><br/><b>D</b></p>               | <p><b>C</b>: short locking frame hook<br/><b>D</b>: Long locking frame hook<br/>Qty = 1 each</p> |  |  |
|  <p><b>E</b></p>                            | <p>left side wheel holders with ratchet straps<br/>Qty = 2 each</p>                              |  |  |
|  <p><b>F</b></p>                            | <p>right side wheel holders with ratchet straps<br/>Qty = 2 each</p>                             |  <p><b>I</b> main pivot bolt, washer and nut<br/>1/2-20 thread<br/>Qty = 1 each</p> |  |
|  <p><b>G</b></p>                            | <p>wheel support tubes<br/>Qty = 2</p>   |  <p><b>J</b> 10mm carriage bolts, spacers and nuts<br/>Qty = 4 each</p>             |  |
|   |  |  <p><b>K</b> 6mm screws<br/>Qty = 3</p>   |  |

## 1: Install Hitch Tube (B) into vehicle's trailer hitch.

Slide the hitch tube **A** into the 2" trailer hitch until it stops (Fig. 1, 2). Remove locking head from the locking hitch pin and insert pin through the hole in the trailer hitch and hitch tube until it passes through the opposite side. Be sure the pin passes through the internal tightening loop (located inside the hitch tube, Fig. 3). Push the locking head onto the end of the pin.

Tighten the front lever until all the play is taken out between trailer hitch and hitch tube (Fig. 4). After tightening, front lever should always be pointed upwards or to the side to avoid damage when going up or down steep driveways.

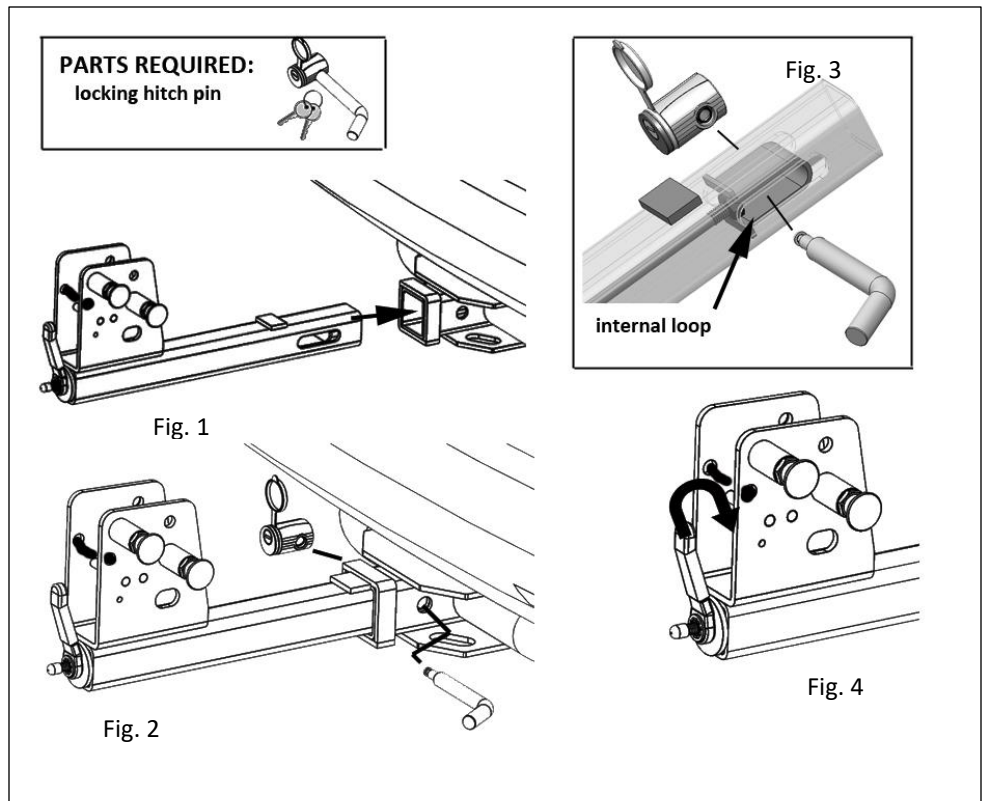

## 2: Attach Main Frame (A) to Hitch Tube (B):

**TOOLS REQUIRED: Two 19mm or ¾" wrenches or adjustable wrenches that open to ¾"**

Push the plastic sleeve forward so that all three holes are visible. Retract the front spring pin and align the holes.

Place the main frame **A** with plastic sleeve into the bracket of the hitch tube **B** per Fig. 5.

Insert the bolt **I** and washer through the pivot bolt holes. Install nut and washer to bolt end. Tighten using two adjustable, 19mm or ¾" wrenches. (Figs. 6, 7)

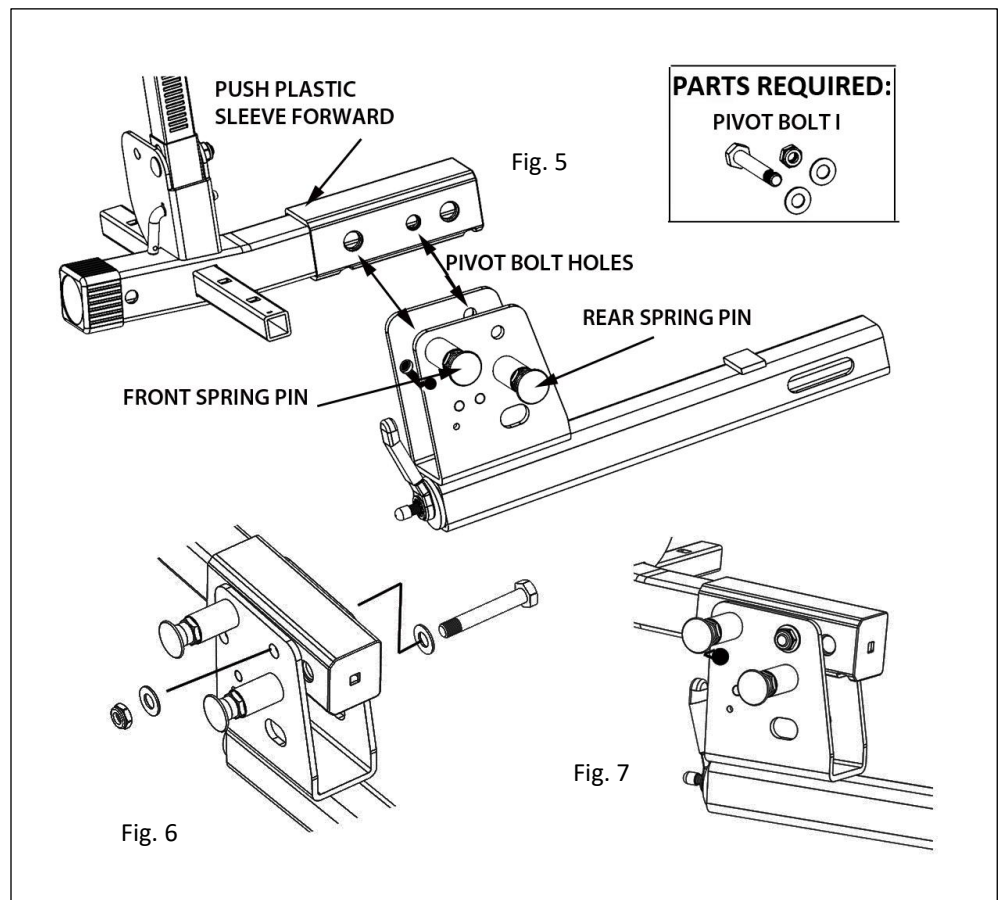

### 3: Attach wheel support tubes and wheel tube brace to main frame

Per Fig. 8, 9, slide the wheel tubes onto the main frame with the wheel tube's square holes facing up. Position the tubes so that the holes are aligned.

Position brace H on top of the wheel tubes per Fig. 10, 11. Insert carriage bolt J through the holes, and install the thick round washer and nut onto the end of the bolt. Repeat for the other three bolts. Tighten using included socket wrench. Refer to Figs. 12-13

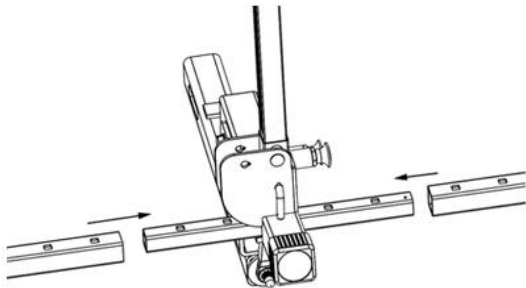
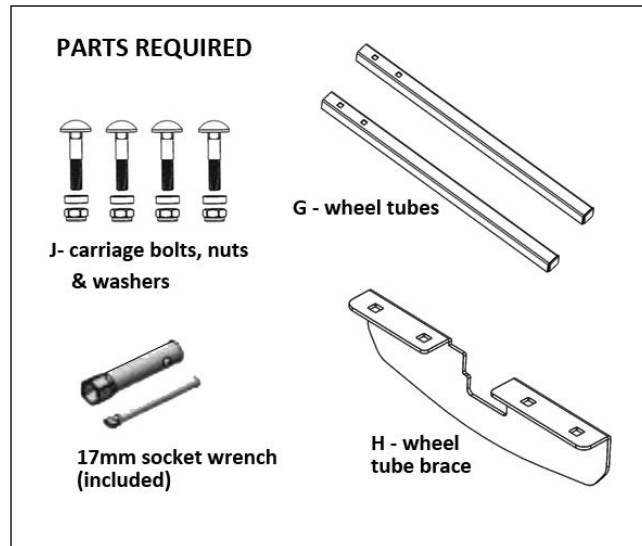

Fig. 8

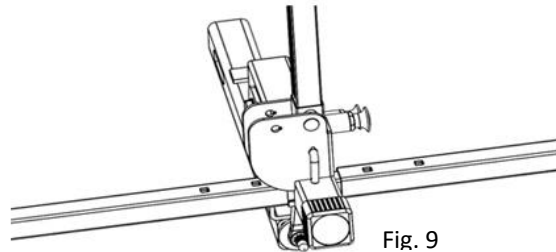

Fig. 9

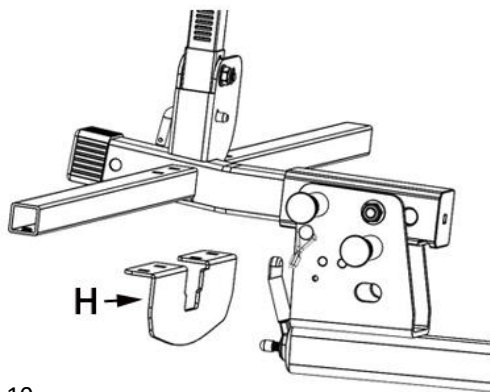

Fig. 10

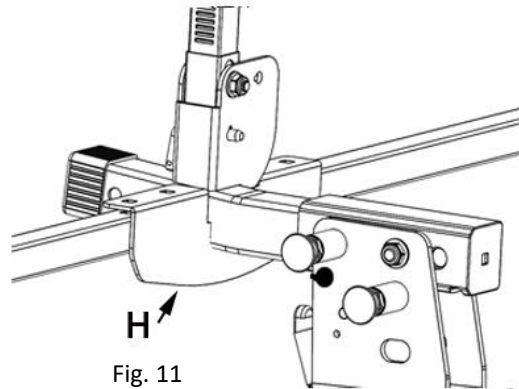

Fig. 11

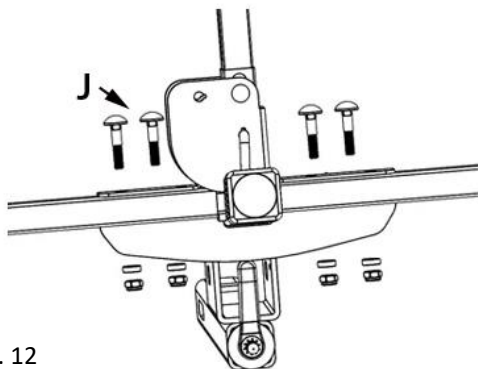

Fig. 12

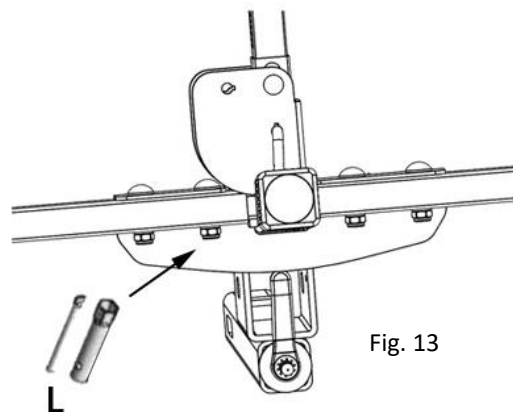

Fig. 13

#### 4: Install frame hooks & wheel holders:

To change the post from folded to “in use” position: rotate & remove the keyed L pin, rotate the post, then re-insert the L pin in the lower hole. Be sure the handle of the pin is pointing downwards to lock it into position. Refer to Fig. 14, 15.

**To install the locking frame hooks:** Spring loaded buttons on the frame hooks must be in the unlocked position per Fig. 18. Place the long frame hook (D) on top of the square post (A) with the hook facing the vehicle. Push the button in and slide the frame hook down onto the post. Repeat for the short frame hook (C) facing in the opposite direction, per Fig. 16. Note: Frame hooks can be installed with the short hook facing the vehicle by using the “ratchet teeth” located on the opposite side of the post.

**Using the clamps:** Once the clamp is installed, it can only be raised by pushing in the button. To lock the frame hook, insert the key and rotate clockwise, per Fig. 18

**Tip: Push down on the plastic housing, not the metal hook**

**Optional post stop screw:** If you do not need to remove the frame hooks from the post for bike mounting or removal, then install screw K into post per Fig.17 with Phillips screwdriver.

**Install wheel holders:** Loosen the knobs on the wheel holders and slide them onto the tubes per Fig. 19. Final positioning will be done when installing bikes.

#### PARTS REQUIRED: Frame hooks (C & D), Wheel Holders (E & F), screw K

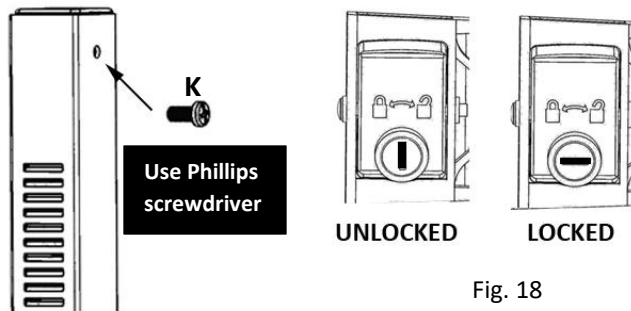
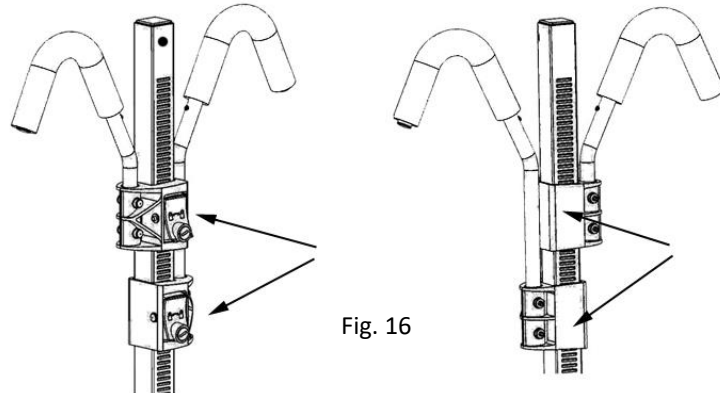
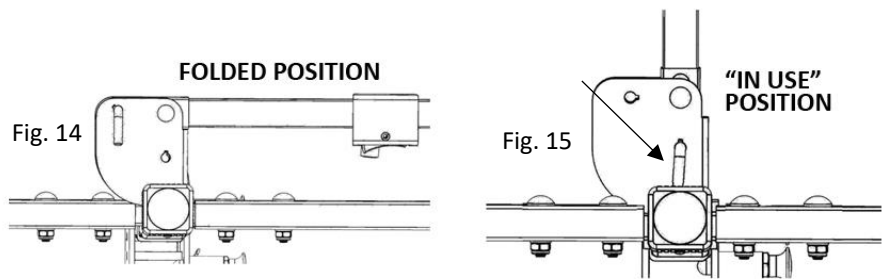

Fig. 17

Fig. 18

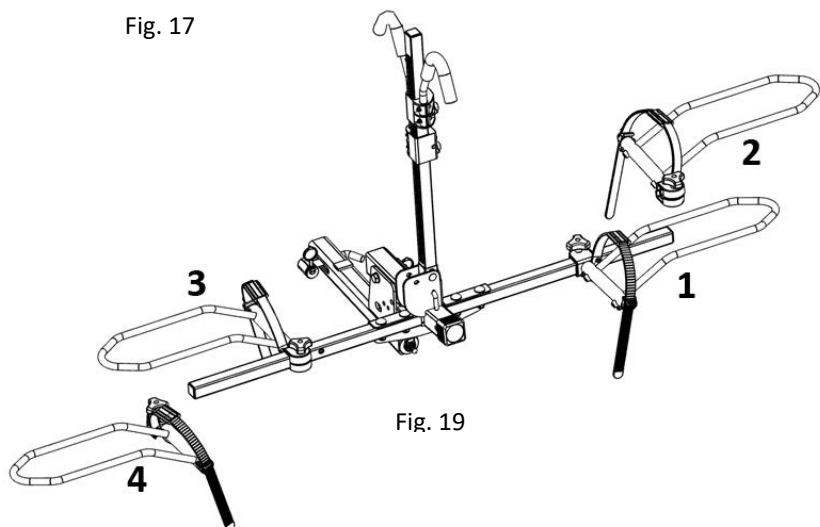

Fig. 19

**5: Installing wheel holder stop screws (Item K):**

After determining the final position of the wheel holders, install the two stop screws (K) into the bottom of the wheel tubes as indicated in Fig. 20. Use Phillips screwdriver.

**6: Fold-up function:**

R remove the L pin and rotate the vertical post to its folded position. Reinsert the L pin. Next, retract or pull back the front spring pin per Fig. 21 and rotate the rack towards the rear of the car until it “clicks” into the folded position. To return the rack to its “in use” position, retract the rear spring pin and gently lower the rack until it clicks into it’s in use position.

**7: Tilt-down function:**

Per Fig. 22, Locate snapper pin. Per Fig. 23, remove snapper pin, retract the front spring pin and gently lower the rack down to its tilted position. Follow reverse steps to bring the rack back to its “in use” position. Be sure to re-install the snapper pin.

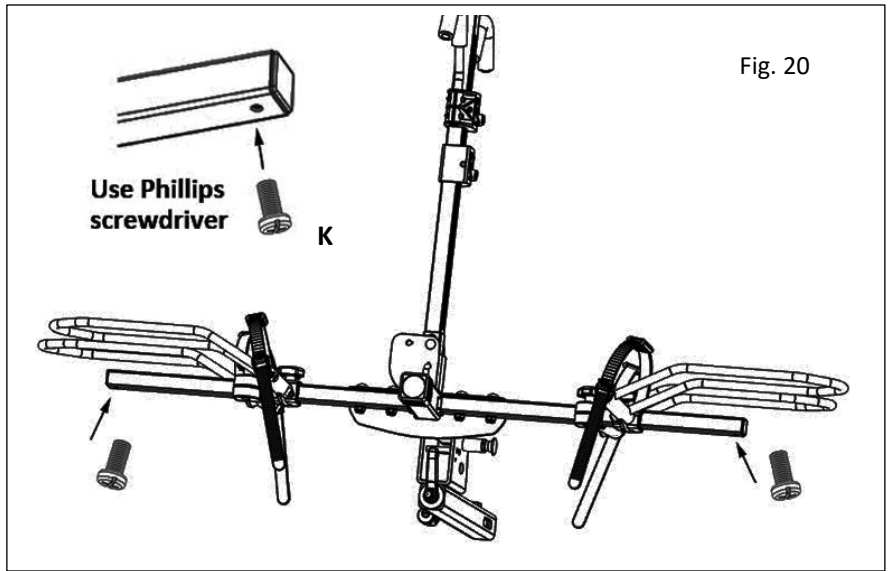

Fig. 20

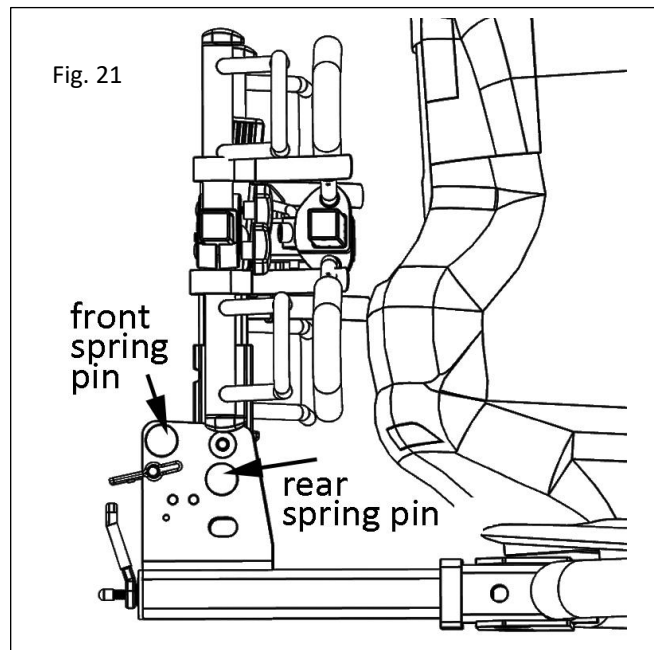

Fig. 21

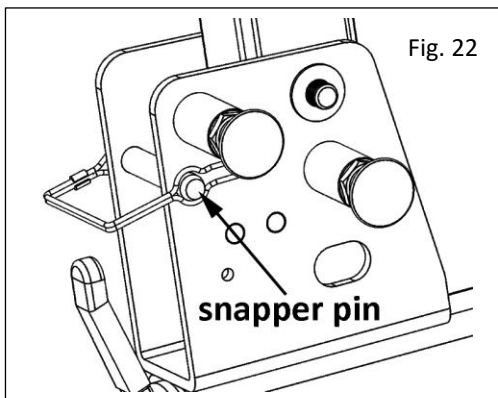

Fig. 22

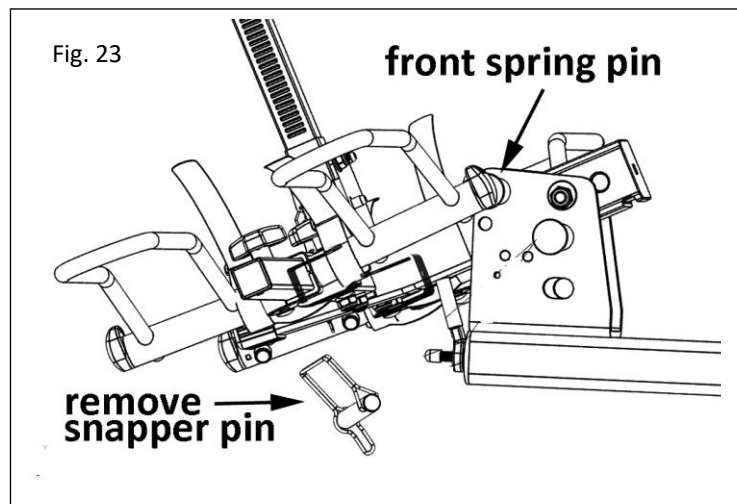

Fig. 23

## 8: Installing bikes on rack

**Remove battery before mounting bikes on rack.**

*Note: The wheel holders on this rack will fit tire widths up to 5" wide. Please see Fig. 27 below.*

Place the inside bike (bike closest to the vehicle) in front of the rack and slide the wheel holders so they align with the bike's wheels. **Try to locate the wheel holders so that the frame hook will rest near the bike's lowest point of the top tube.** Place the bike onto the wheel holders and make final wheel holder position adjustments if necessary. Tighten knobs securely. Push the frame hook down onto the bike's frame until fully engaged per Fig. 24. (Push down on the plastic housing, not the metal hook). Lock the frame hook. **Do not over-compress the padded hook onto the frame.** For square shaped top tubes you can use extra padding (such as a sponge or piece of cloth) as needed.

**Ratchet strap wheel holders:** Rotate the wheel ratchet strap and lay it on top of the bike's wheel (ratchet teeth "up"). Insert the strap into the buckle and pull tight. Do not overtighten. Repeat for the second wheel. To release the strap, push in the spring loaded tab and pull the strap out of the buckle. Note: Straps should be inserted into the buckle when the rack is not in use.

**Carrying two bikes:** When carrying two bikes, the handlebars must be staggered. Repeat for the outside bike, with handlebars positioned with the handlebars on the opposite side per Fig. 26. Lock bikes to rack with included security cable.

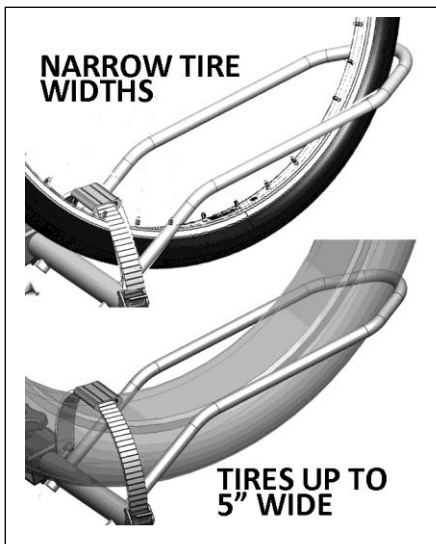
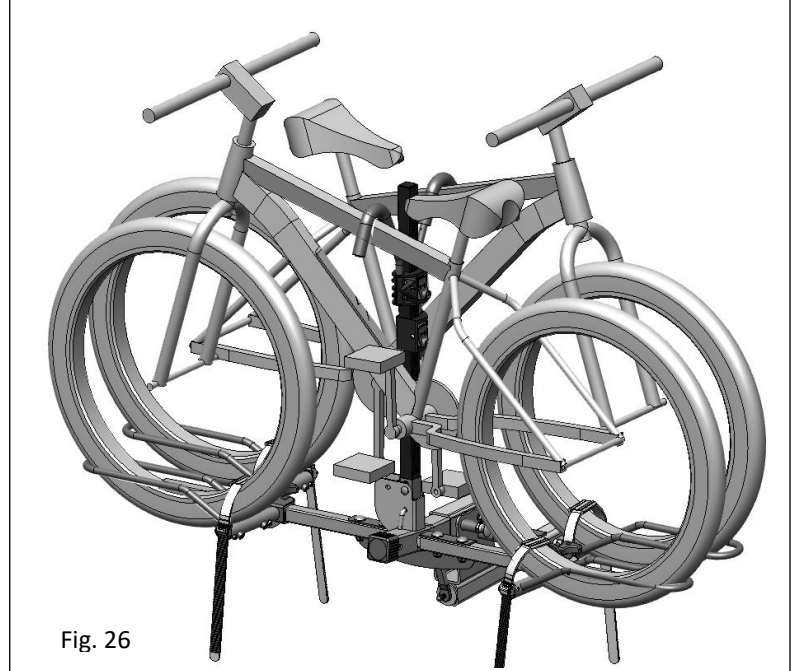
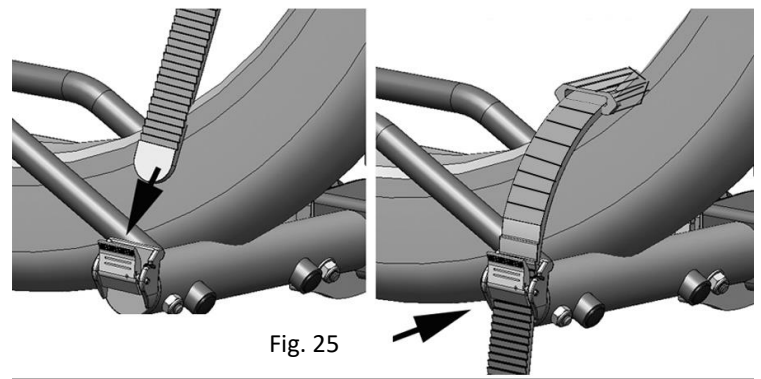

Fig. 27





**9. Loading heavy bikes:** If you are carrying two heavy E-bikes, it is easiest to load the inside bike (closest to the vehicle) first. Lower the post and lift the bike's front wheel onto the rack (Fig. 28). Then lift the rear wheel onto the rack. Now "walk" the bike over to the inside bike wheel holders (Fig. 29). Rotate the pedals so the post will not interfere with them when rotating the post back to its "in use" position. Rotate and secure the post (Fig. 30). Secure the bike by pressing down then locking frame hook and attach wheel holder ratchet straps. Now load the second (or outside) bike by lifting the front wheel into the wheel holder first, then the rear wheel. Press down and lock frame hook, then attach wheel ratchet straps. Use the included security cable to lock your bikes.

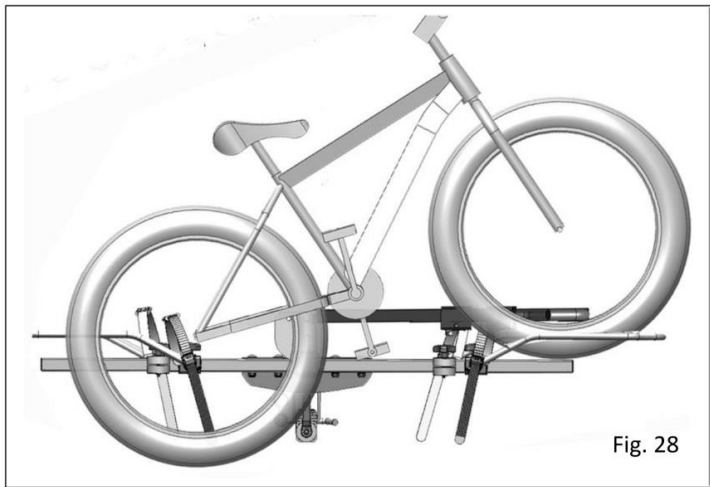

Fig. 28



Fig. 29

Fig. 30

**10. Small Wheel Adapter**

**SOLD SEPARATELY**

The small wheel adapter is a two piece bracket which shortens the inside length of the wheel holder. **It is intended for use only with 20" diameter fat tire bikes that feature a rear derailleur style gear changer.**

**USE ON REAR WHEEL ONLY**

**DO NOT USE WITH ANY 24" TO 29" DIAMETER WHEEL BIKE. DOING SO WILL VOID WARRANTY.**

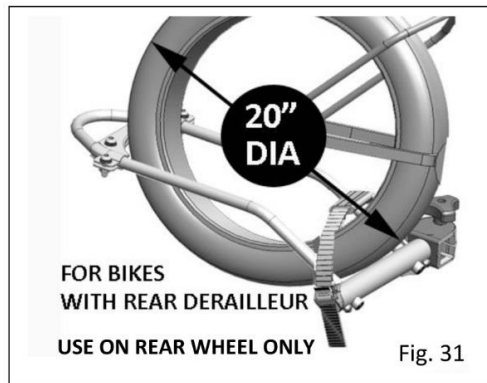

Fig. 31

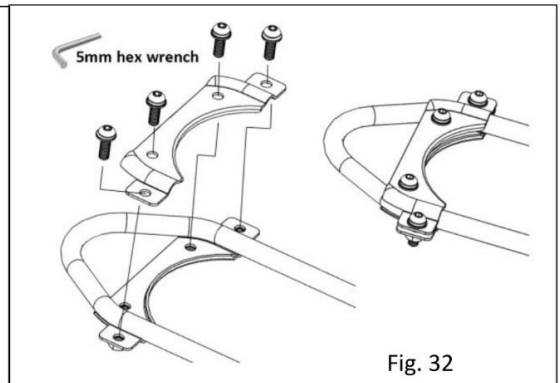

Fig. 32

To install the small wheel adapter, place the bottom half (with welded nuts) below the "pointed end" of the rear wheel holder. Position the upper half on top and install bolts. Tighten bolts securely using the included 5mm hex wrench. Refer to Fig.32 .

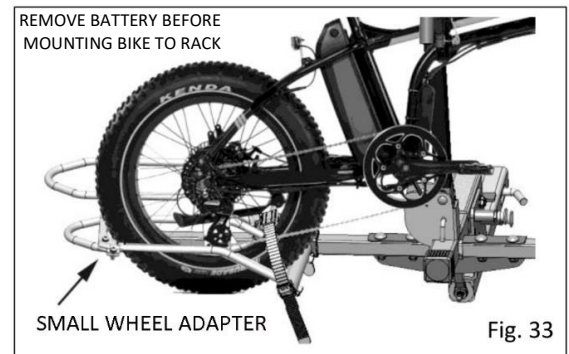
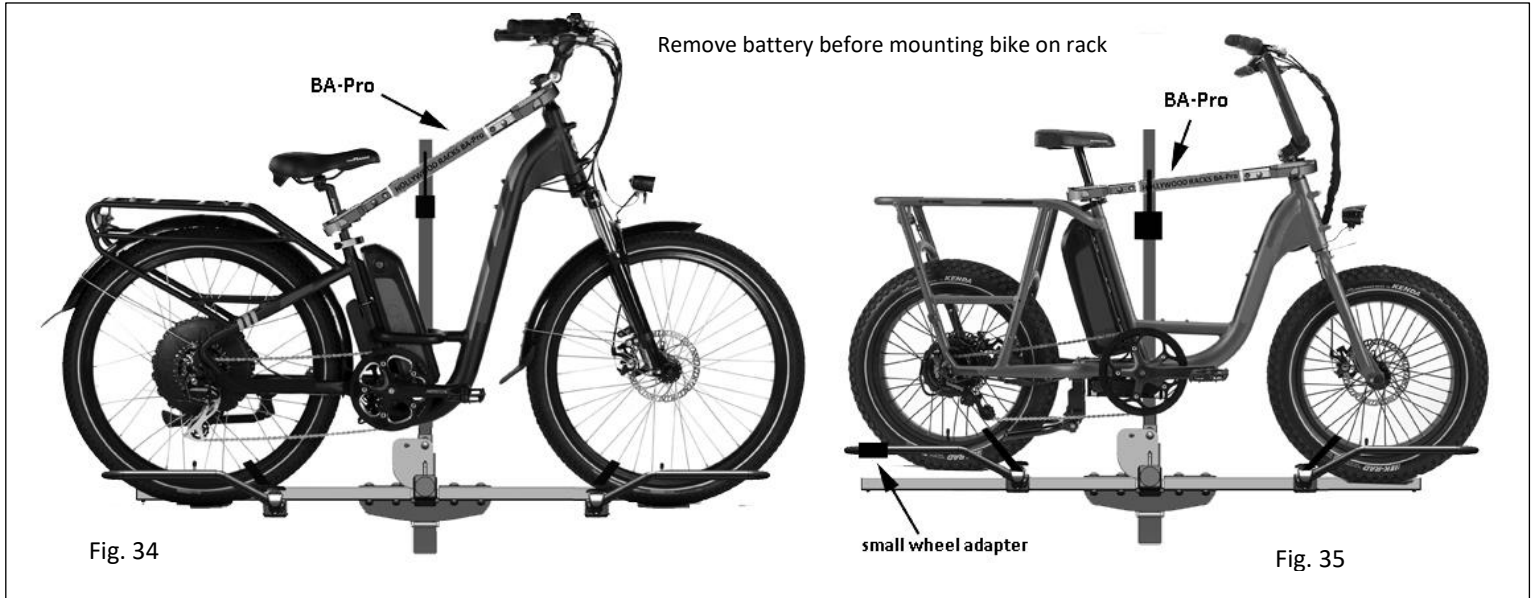

Fig. 33

## 11: BA-Pro Bike Adapter (SOLD SEPARATELY)

The Hollywood BA-Pro is a heavy-duty frame adapter which creates an artificial “top tube” for your bike. Certain bike frames, such as step thru and utility bikes will require this accessory.



### Limited Lifetime Warranty (effective January 1, 2008):

Hollywood Racks will warrant its car racks and accessories during the time that an original retail purchaser owns the product subject to the exclusions and limitations of this warranty. Hollywood Racks will remedy defects in materials and workmanship by repairing or replacing (at its option) a defective part without charge for labor or parts. Hollywood Racks may elect (at its option) to issue a refund equal to the purchase price paid for the product. This warranty does not cover problems caused by normal wear and tear including (but not limited to) weather, scratches, dents, rust, accidents, unlawful vehicle operation, misuse, abuse, neglect, theft, unauthorized modifications, or unauthorized repair. No warranty is given for defects resulting in incorrect assembly, incorrect installation onto the vehicle, installation on a “no fit” vehicle, incorrect attachment of bicycles onto the rack, or overloading of the rack’s weight restrictions. This warranty terminates if the original retail purchaser transfers the product to any other person. If a product is believed to be defective, the original retail purchaser should contact either the original retailer or Hollywood Racks directly at 800-747-4085 or at [info@hollywoodracks.com](mailto:info@hollywoodracks.com) **Disclaimer of Liability:** Repair or replacement of a defective product or the issuance of a refund or credit (as determined by Hollywood Racks) is a purchaser’s exclusive remedy under this warranty. Damage to a purchaser’s vehicle, cargo, bicycles and or to any other person is excluded. This warranty is expressly made in lieu of any and all other express warranties, whether oral or written. Hollywood Racks shall not be liable for any direct, indirect, consequential, incidental, special, punitive or any other damages in connection with the purchase, use or handling of this product. Some states do not allow the exclusion or limitation of consequential or incidental damages and the above limitation may not apply to you. This warranty gives you specific legal rights and you have other rights, which vary from state to state.

**Hollywood Racks**  
12812 South Spring Street Los Angeles, CA 90061 (800) 747-4085 (310) 516-8600 Fax (310) 516-8955  
[www.hollywoodracks.com](http://www.hollywoodracks.com) Customer Service: [info@hollywoodracks.com](mailto:info@hollywoodracks.com)  
Made in Taiwan SportRider Model HR1500 V1.1 07-2020