

Hollywood Racks Assembly & installation instructions for models:

HR1450Z-R FOR RECUMBENT BIKES

- For use on 2" hitches only. Do not use a 1 ¼" -2" hitch adapter.
- Maximum weight per bicycle is 50lbs. Not intended for use with motorized bicycles, mopeds or motorcycles.
- Not intended for use on any trailer, fifth wheel or vehicle being towed by another vehicle.

For video assembly & installation instructions, please visit hollywoodracks.com

Fig.1

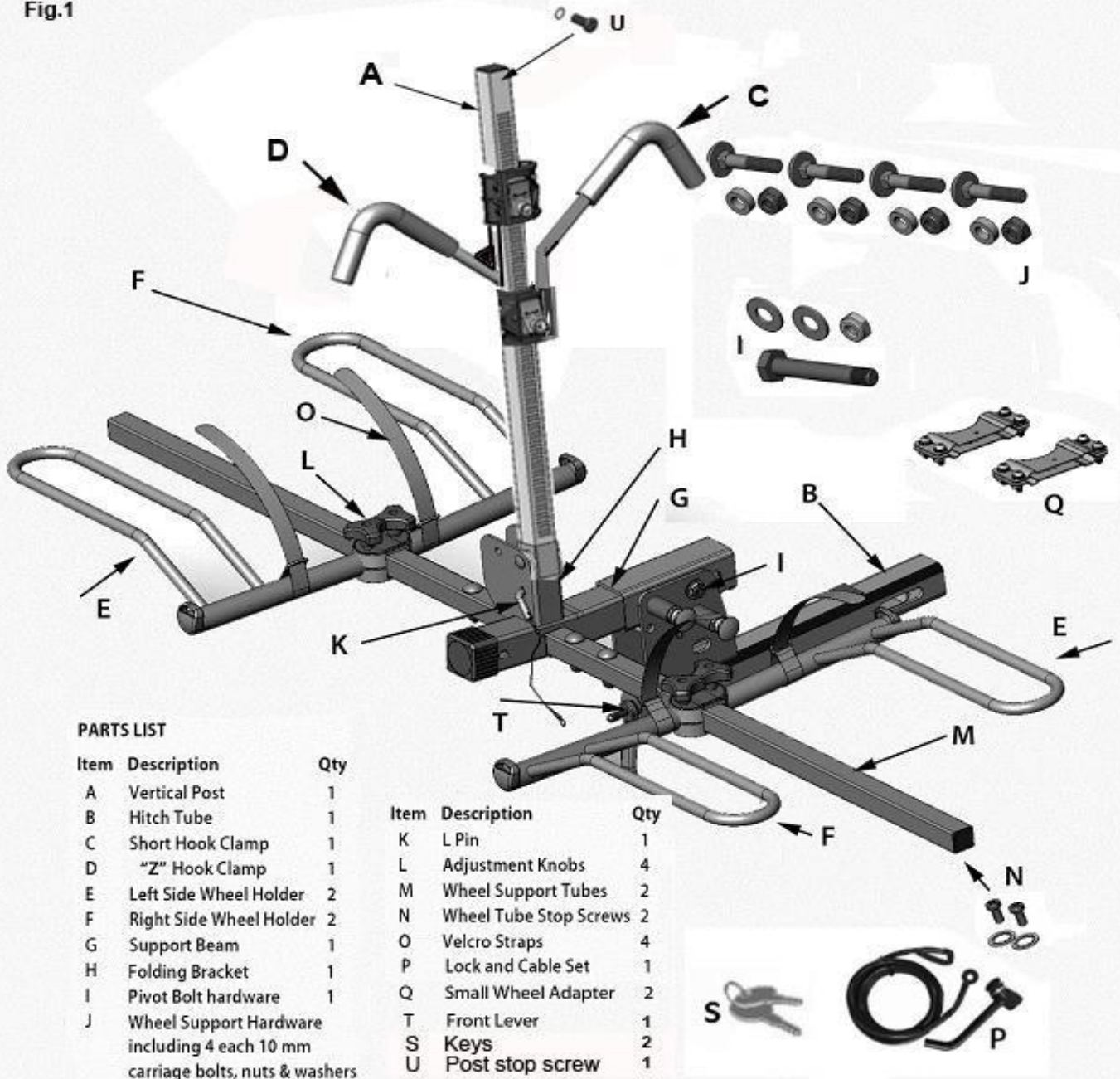

PARTS LIST

Item	Description	Qty
A	Vertical Post	1
B	Hitch Tube	1
C	Short Hook Clamp	1
D	"Z" Hook Clamp	1
E	Left Side Wheel Holder	2
F	Right Side Wheel Holder	2
G	Support Beam	1
H	Folding Bracket	1
I	Pivot Bolt hardware	1
J	Wheel Support Hardware including 4 each 10 mm carriage bolts, nuts & washers	

Item	Description	Qty
K	L Pin	1
L	Adjustment Knobs	4
M	Wheel Support Tubes	2
N	Wheel Tube Stop Screws	2
O	Velcro Straps	4
P	Lock and Cable Set	1
Q	Small Wheel Adapter	2
T	Front Lever	1
S	Keys	2
U	Post stop screw	1

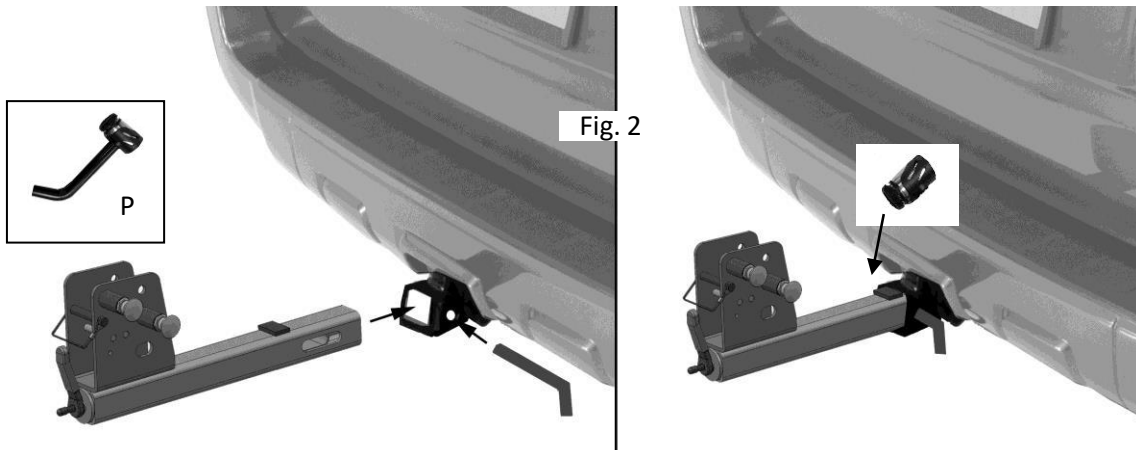

Step 1: Install Hitch Tube (B) into vehicle's trailer hitch.

Slide the hitch tube into the trailer hitch until it stops. Remove locking head from hitch pin (P) and insert pin through the hole in the trailer hitch and hitch tube until it passes through the opposite side. Tighten the front lever until good and snug. If you intend on using the rack after assembly, then install the locking head onto the end of the hitch pin, otherwise it is not required to complete the assembly. Front lever (T) position after tightening should always be pointed upwards or to the side to avoid damage when going up or down steep driveways.

Step 2: Attach Support Beam (G) to Hitch Tube (B):

Refer to Fig. 3: Retract the front spring pin insert the main beam into the bracket of the hitch tube. The front spring pin should drop into hole G1. Next, align hole G2 with hole B1. Insert the bolt I and washer through holes G2 and B1. Install nut and washer to bolt end. Tighten using adjustable, 19mm or ¾" wrenches. Hole G3 should be partially visible after assembly.

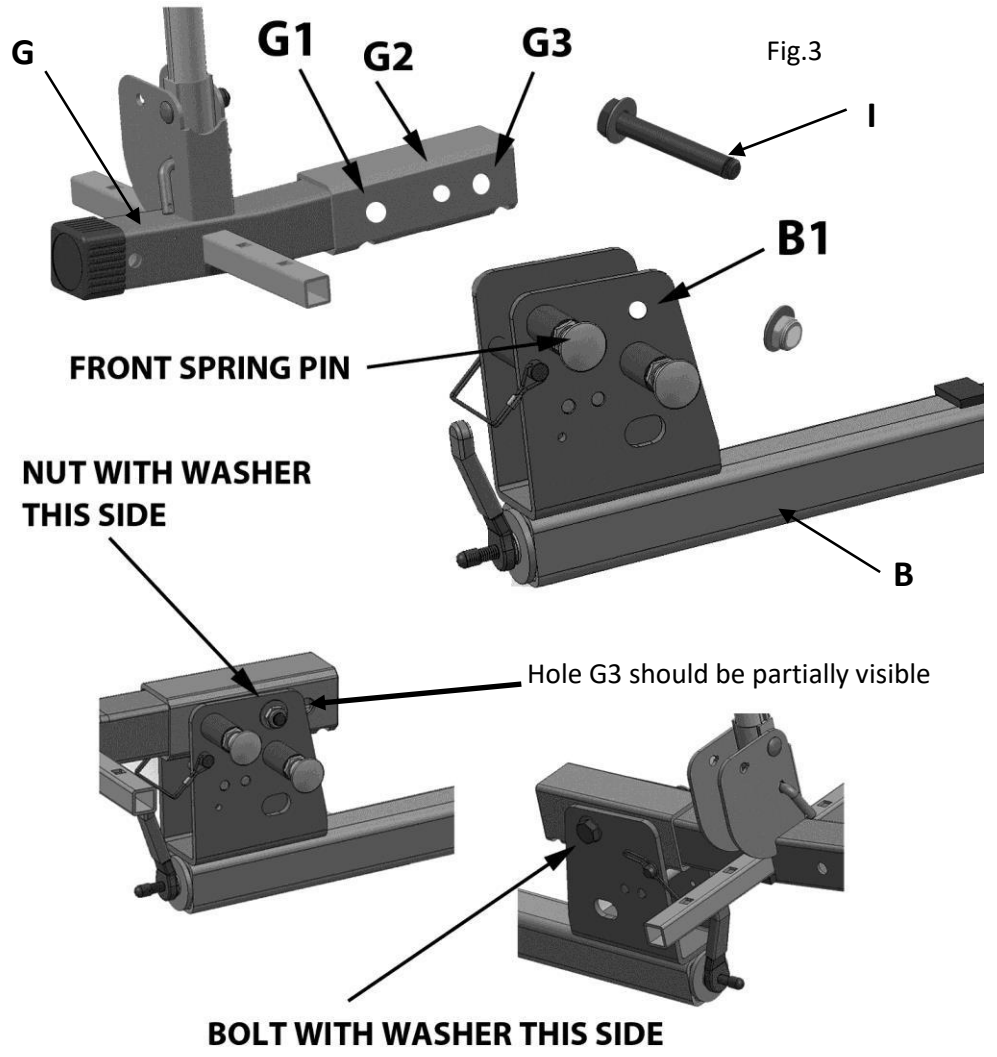

Step 3: Attach Wheel Support Tubes (M) to Support Beam (G):

Refer to Fig. 4: Slide wheel tubes over square posts on the support beam. Square holes on the wheel tubes should be on top. Insert carriage bolts (J) through holes, install thick round washer and nut onto bolt end. Tighten securely with adjustable or 17mm wrench.

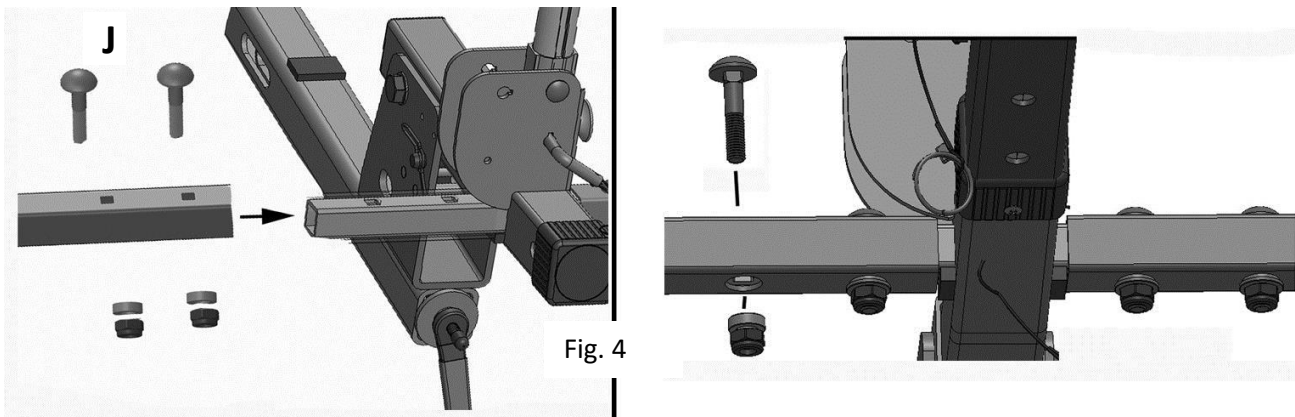

Step 4: Installing the ratcheting frame hooks

Refer to Fig. 5: Rotate and remove the L Pin (K) from the lower hole and rotate the post to the vertical or "in use" position. Insert the L pin in the upper hole and rotate so the handle part of the pin is pointing down.

Be sure release buttons on the ratchet hooks are in the unlocked position per Fig 7A. Next, position the long frame hook (D) on top of the square post (A) with the hook facing the vehicle. Push the release button in and slide the frame hook down onto the post. Remember, the release button should be pushed in when installing the hook onto the post. Repeat for the short hook (C) facing in the opposite direction, per Fig. 6

Using the clamps: Once the clamp is installed, it can only be raised by pushing in the release button. To lock the frame hook, insert the key and rotate clockwise, per Fig. 7B

Tip: Push down on the plastic housing, not the metal hook

Optional post stop screw: If you do not need to remove the frame hooks from the post for bike installation, then install post screw (U) into post per fig. 8 with Phillips screwdriver.

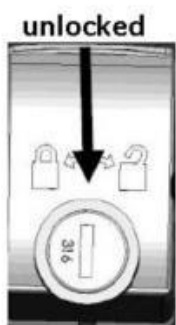
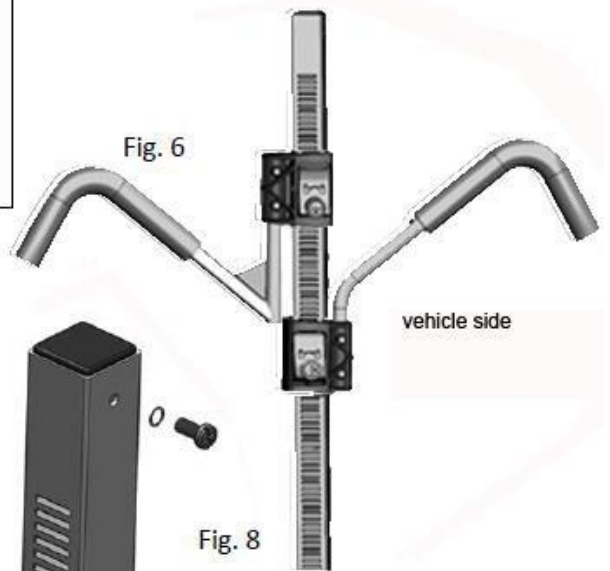
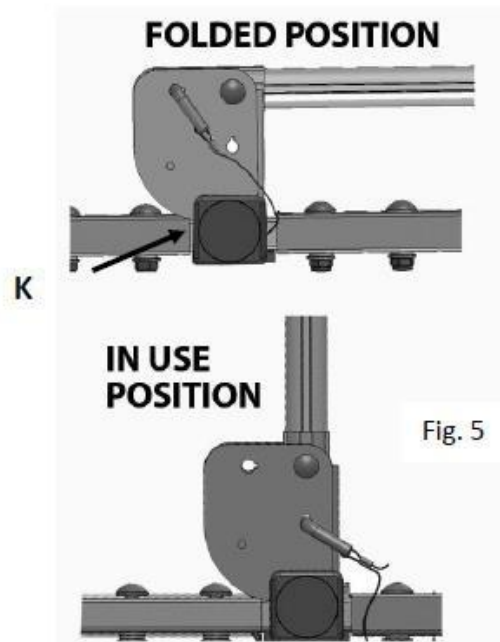

Fig. 7A



Fig. 7B

Step 5: Install Wheel Holders

Loosen the knobs on the wheel holders and slide them onto the wheel tubes per Fig. 9. They are snug, you may need to tap them on. Configure the wheel holders per Fig. 10. Install the wheel holder for inside bike passenger side first (1), next the outside bike passenger side (2), then the inside bike's driver side (3), and finally the outside driver side wheel holder (4).

Fig. 9

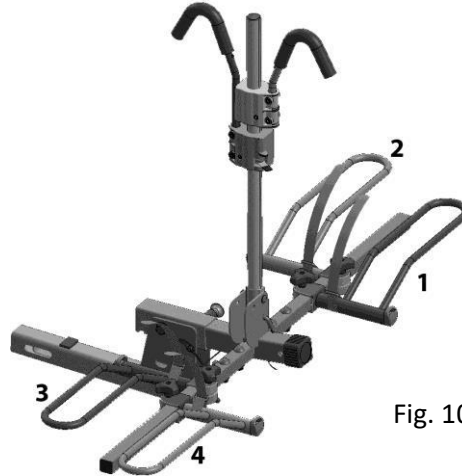
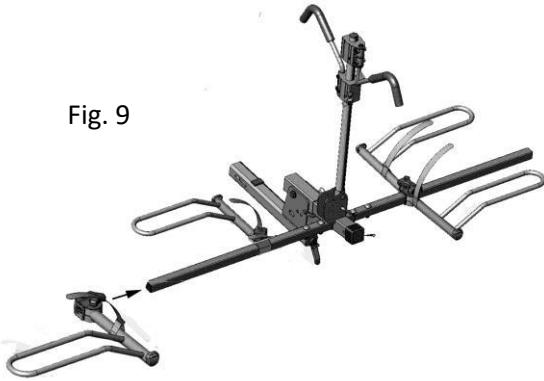

Fig. 10

Step 6: Installing wheel holder stop screws:

After determining the final position of the wheel holders, install the two stop screws (N) into the bottom of the wheel tubes as indicated in Fig. 11. Use Phillips screwdriver.

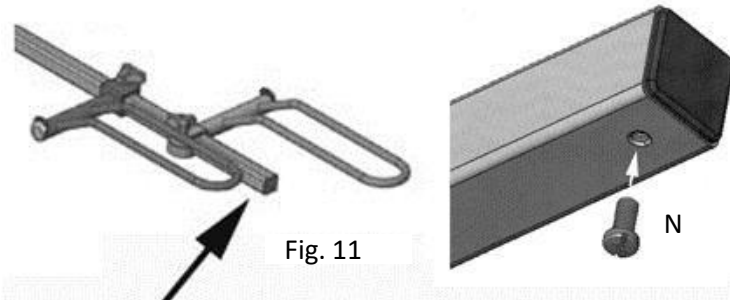

Fig. 11

7: Fold-up function:

Per Fig. 5, remove the L pin (K) and rotate the vertical post to its folded position. Reinsert the L pin. Next, retract or pull back the front spring pin per Fig. 12 and rotate the rack towards the rear of the car until it "clicks" into the folded position. To return the rack to its "in use" position, retract the rear spring pin and gently lower the rack until it "clicks" into its in use position.

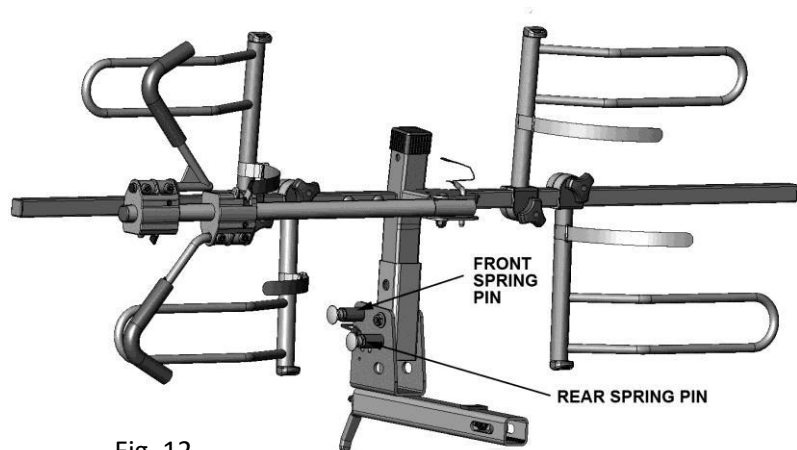

Fig. 12

8. Tilt-down function:

Per Fig. 13, remove snapper pin. Per Fig.14, retract front spring pin and gently lower the rack down to its tilted position. Follow reverse steps to bring the rack back to its “in use” position.

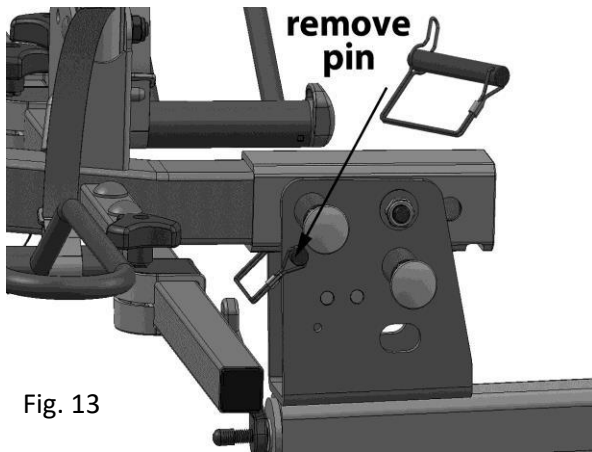

Fig. 13

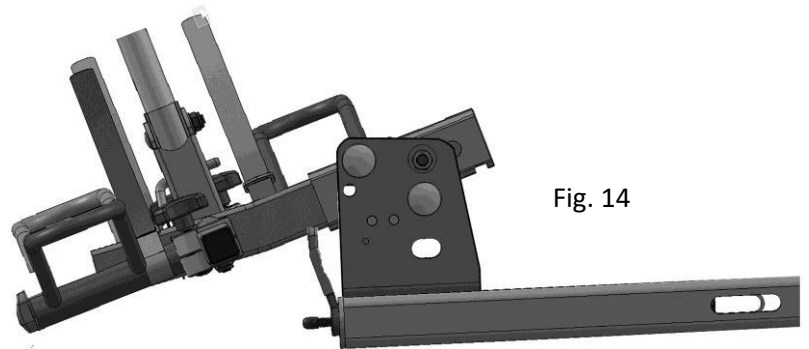

Fig. 14

9. Small Wheel Adapter

For bikes with 16” wheels, use the “small wheel” adapter (item Q) to prevent the wheel from falling through the wheel holder. Place the upper section on top of the wheel holder, then position the bottom section directly below it. Insert the bolts and lightly tighten using the included 5mm hex wrench. Slide the wheel adapter to the desired position then tighten all 4 bolts securely.

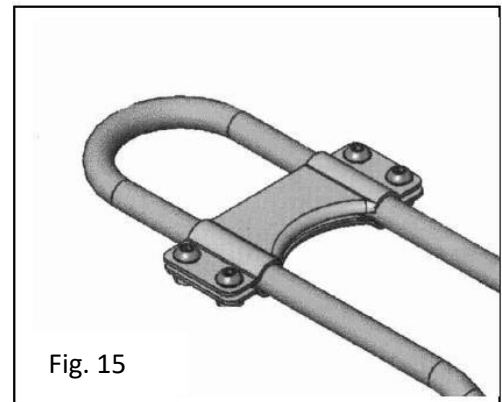

Fig. 15

10. Installing Bikes

Carrying one bike: Place the bike in front of the rack and slide the outside wheel holders so they align with the bike’s wheels. **Try to locate the wheel holders so that the frame hook will rest near the bike’s lowest point of the top tube.** Place the bike onto the wheel holders and make final wheel holder position adjustments if necessary. Tighten knobs securely. Push the frame hook down onto the bike’s frame until fully engaged per Fig. 16 (Push down on the plastic housing, not the metal hook). **Do not over-compress the padded hook onto the frame.** For top tubes other than round shape, you can use extra padding (such as a sponge or piece of cloth) as needed. Tighten the Velcro straps **G** around the bike’s wheels per figure 17. As the final step, pull up on the plastic housing to double check it is properly engaged. Lock bike to rack with included security cable.

Fig. 16

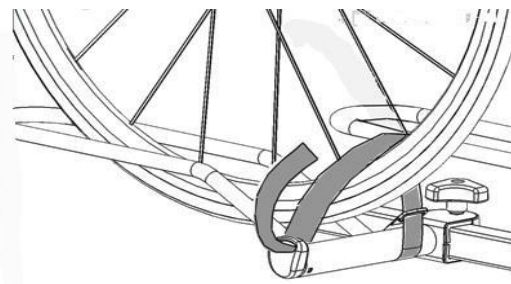

Fig. 17

Fig. 18



Note: image shown with “y”
version clamps

Carrying two bikes: When carrying two bikes, the handlebars must be staggered. Try to place the heaviest bike closest to the vehicle. Depending on the size of the bikes and the length of their wheel bases, the location of the wheel holders will vary. Place the inside bike in front of the rack. Loosen the knobs on the inside wheel holders and slide the wheel holders so they align with the bike's wheels. **Try to locate the wheel holders so that the frame hook will rest near the bike's lowest point of the top tube.** Place the bike onto the wheel holders and make final wheel holder position adjustments if necessary. Tighten knobs securely. Push the frame hook down onto the bike's frame until fully engaged per Fig. 15. Push down on the plastic housing, not the metal hook. **Do not over-compress the padded hook onto the frame.** For top tubes other than round shape, you can use extra padding (such as a sponge or piece of cloth) as needed. Tighten the Velcro straps **G** around the bike's wheels per Fig. 17. As the final step, pull up on the frame clamp to double check it is properly engaged. Repeat for the outside bike, positioned with the handlebars on the passenger side. Lock bikes to rack with included

Installing locking cable

To lock two bikes, locate the 8' security cable included with the rack. Identify the cable's "loop" end and "lug" end

Installing locking cable continued:

Thread the 8' cable through the bikes so that both the "loop" and "lug" end are near the vehicle's hitch and locking hitch pin (Fig. 19). Pass the lug through the loop. Remove the locking head from the hitch pin, then slide the lug over the hitch pin (Fig. 20). Install the locking head onto the hitch pin.

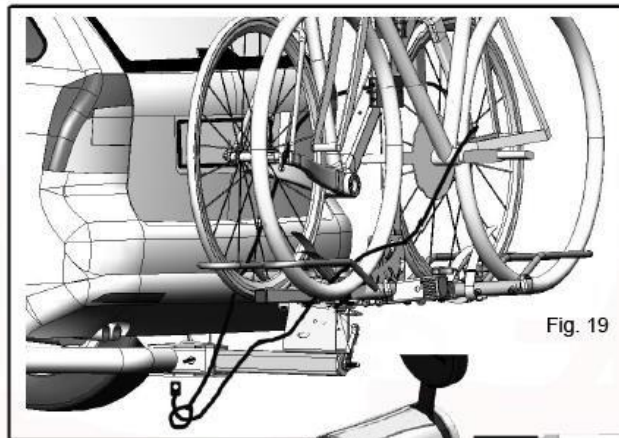
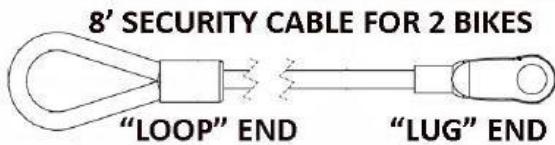

Fig. 19



8' SECURITY CABLE FOR 2 BIKES

"LOOP" END

"LUG" END

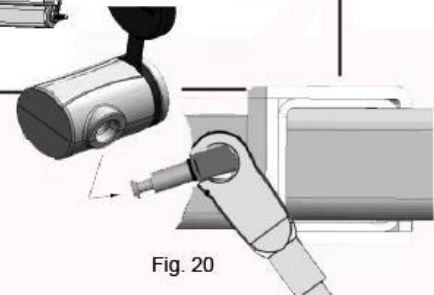
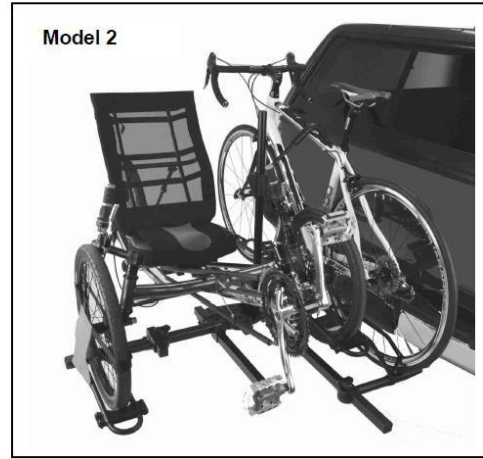
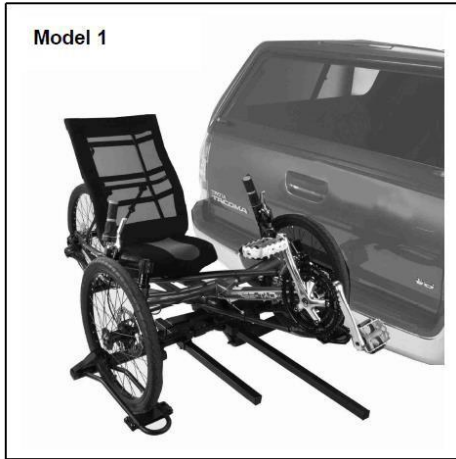

Fig. 20

Trike Adapter Optional Accessory (sold separately)

Trike Adapter Model 1: Allows the carrying of one trike only on the rack

Trike Adapter Model 2: Allows the carrying of one trike plus one bike (standard or recumbent)



Double check before driving:

Knobs are tight on all wheel holders

Frame hooks are firmly pressed down onto bike frame

Velcro straps are securely fastened

Hitch pin with locking head is installed and secure

Always drive slowly on bumpy or dirt roads

Limited Lifetime Warranty (effective January 1, 2008):

Hollywood Racks will warrant its car racks and accessories during the time that an original retail purchaser owns the product subject to the exclusions and limitations of this warranty. Hollywood Racks will remedy defects in materials and workmanship by repairing or replacing (at its option) a defective part without charge for labor or parts. Hollywood Racks may elect (at its option) to issue a refund equal to the purchase price paid for the product. This warranty does not cover problems caused by normal wear and tear including (but not limited to) weather, scratches, dents, rust, accidents, unlawful vehicle operation, misuse, abuse, neglect, theft, unauthorized modifications, or unauthorized repair. No warranty is given for defects resulting in incorrect assembly, incorrect installation onto the vehicle, installation on a "no fit" vehicle, incorrect attachment of bicycles onto the rack, or overloading of the rack's weight restrictions. This warranty terminates if the original retail purchaser transfers the product to any other person. If a product is believed to be defective, the original retail purchaser should contact either the original retailer or Hollywood Racks directly at 800-747-4085 or at info@hollywoodracks.com **Disclaimer of Liability:** Repair or replacement of a defective product or the issuance of a refund or credit (as determined by Hollywood Racks) is a purchaser's exclusive remedy under this warranty. Damage to a purchaser's vehicle, cargo, bicycles and or to any other person is excluded. This warranty is expressly made in lieu of any and all other express warranties, whether oral or written. Hollywood Racks shall not be liable for any direct, indirect, consequential, incidental, special, punitive or any other damages in connection with the purchase, use or handling of this product. Some states do not allow the exclusion or limitation of consequential or incidental damages and the above limitation may not apply to you. This warranty gives you specific legal rights and you have other rights, which vary from state to state.

Hollywood Racks

12812 South Spring Street Los Angeles, CA 90061 (800) 747-4085 (310) 516-8600 Fax (310) 516-8955

Customer Service Hours: M-F 8:00 AM- 3:00 PM PST www.hollywoodracks.com info@hollywoodracks.com

Made in Taiwan

HR1400Z-R V3 09-2018