

Hollywood Racks Sport Rider Electric Bike Hitch Rack

Model HR1450E - 2 Bike Capacity

- Not to be used on any trailer, fifth wheel or vehicle being towed by another vehicle
- Weight Limit 80 lbs per bike
- 2 bike maximum capacity

PARTS LIST

Item	Description	Qty	Item	Description	Qty
A	vertical post	2	H	receiver tube	1
B	base assembly	1	I	pivot nut	1
B1	Front Cap	1	J	pivot washers	2
C	short hook clamp	2	K	locking hitch pin	1
D	long hook clamp	2	L	security cable	1
E	left wheel holder	4	M	wheel support tube	4
F	right wheel holder	4	N	extension lever	1
G	pivot bolt	1	P	"stop" screws	2
			R	clip	2
SUPPORT FRAME					
S	straight tube	1			
T	Connector tube	2			
U	Cross connector	2			
V	Front main bracket	1			

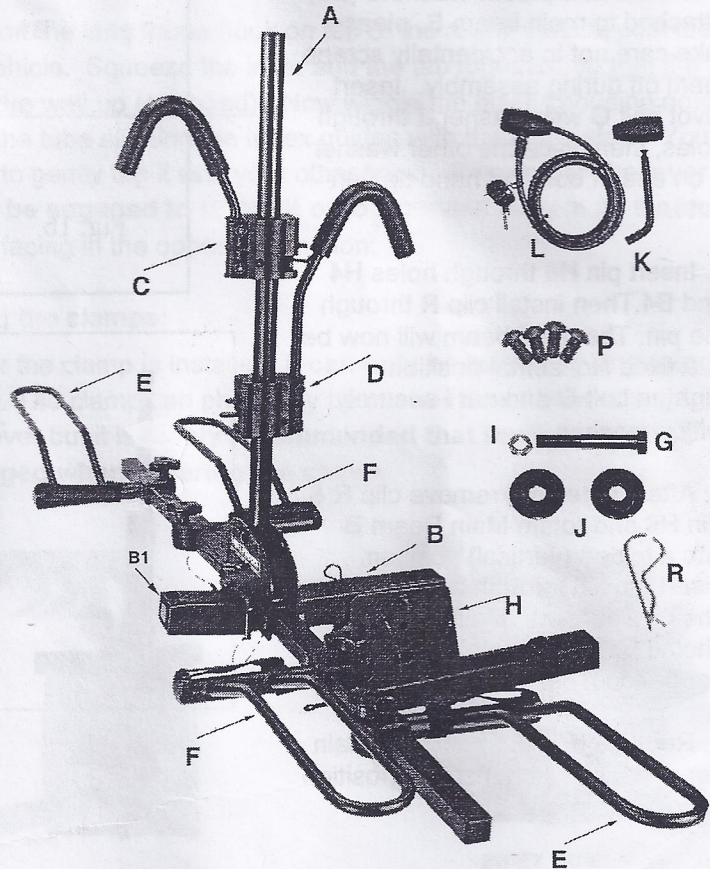
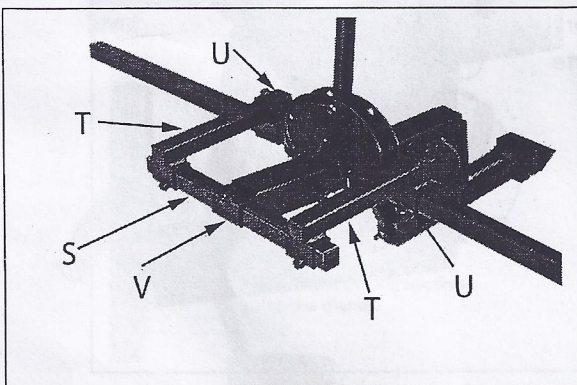
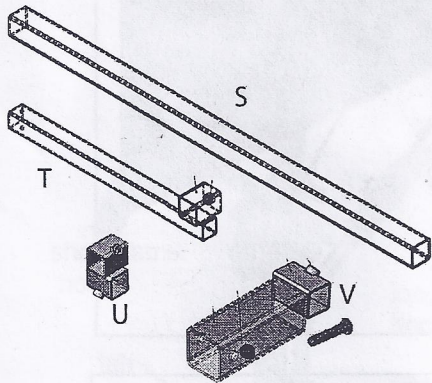

Assembly Instructions:

Tools Required: Two 8" adjustable wrenches or equivalent, Phillips screwdriver.

For ease of assembly, we suggest that you use your vehicle's hitch.

Step 1: Assemble Receiver Tube to Base Assembly

1. Install your receiver tube **H** into the hitch. Unlock hitch pin **K** and insert it through hole in the hitch and the rack. Be sure that the pin passes through the welded loop on the end the bolt attached to the lever **H7**. Tighten the lever **H7** on the front of the insert tube until good and snug. Use this same procedure when using the rack.

2. Gently insert Base Assy **B** into the bracket of Receiver tube **H**, aligning holes **H3** with **B2**. The main beam can rest on pin **H5**. There are two plastic washers (**B3**) attached to main beam **B**, please take care not to accidentally scrape them off during assembly. Insert pivot bolt **G** with washer **J** through holes, then place the other washer **J** on end of bolt and hand tighten nut **I**.

3. Insert pin **H6** through holes **H4** and **B4**. Then install clip **R** through the pin. The main beam will now be in a fixed Horizontal position. Tighten bolt **G** and nut **I** securely with wrenches.

4. After tightening, remove clip **R** & Pin **H6** and rotate Main Beam **B** into a folded (vertical) position. Insert pin **H6** through holes **H2** to check alignment. Main beam should be able to rotate easily, but not be too loose.

5. Remove pin **H6** and rotate main beam back to its horizontal position to continue assembly.

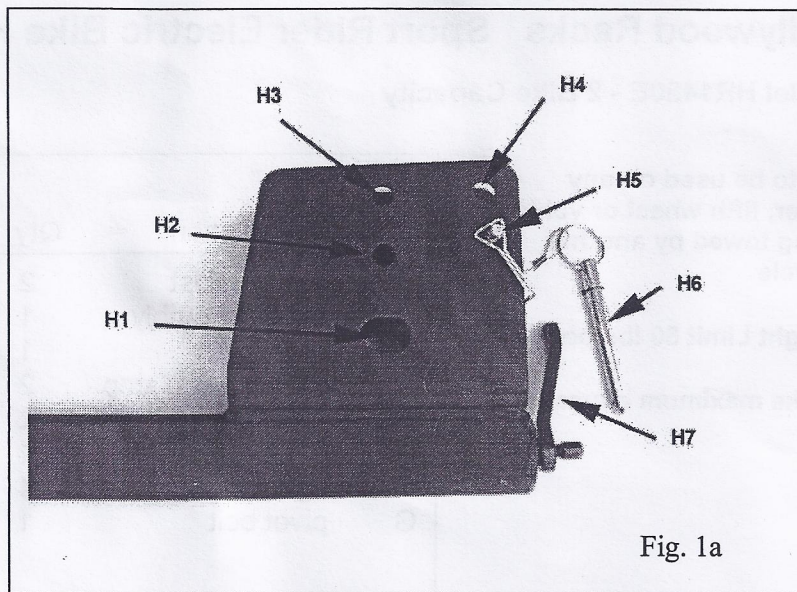

Fig. 1a

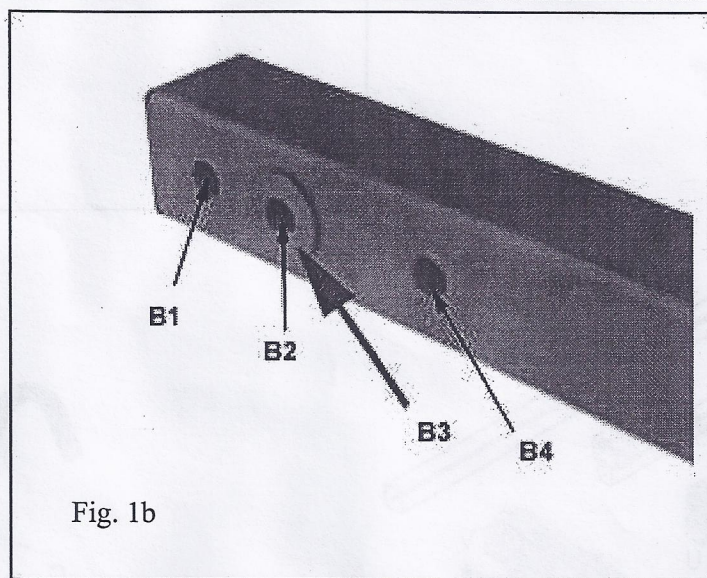

Fig. 1b

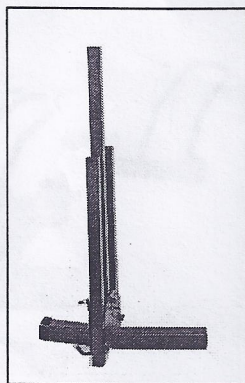

Fig. 1c

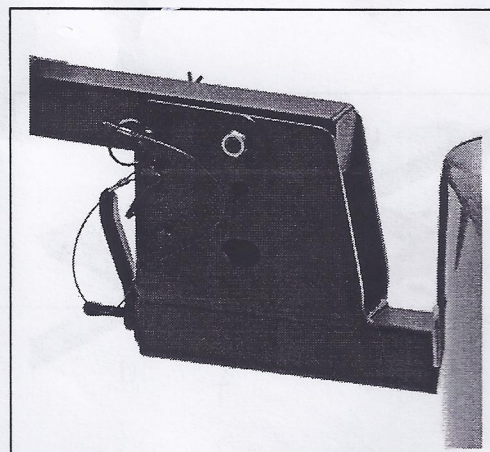
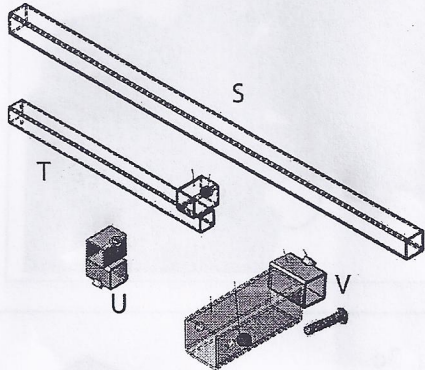

Fig. 1d
"B" base assembly

Step 2: Install Support Frame



SUPPORT FRAME

Part#	Description	Qty
S	Straight tube	1
T	Connector tube	2
U	Cross connector	2
V	Front main bracket	1

1. Remove Front reflector cap using Philips head screwdriver (screw located on bottom of cap)

2. Install front main bracket (V). Align hole with tube, then insert pin and clip. Slide cross connectors (U) onto wheel tubes, "empty hole" on top.

3. Install connector tubes (T) into the cross connectors' "empty holes".

4. Slide straight tube (S) through holes in connector tubes.

5. Tighten using included hex key.

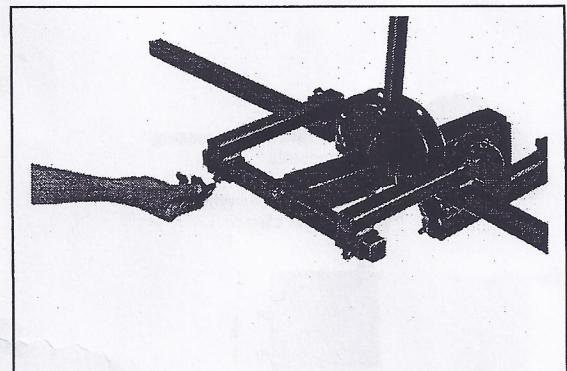
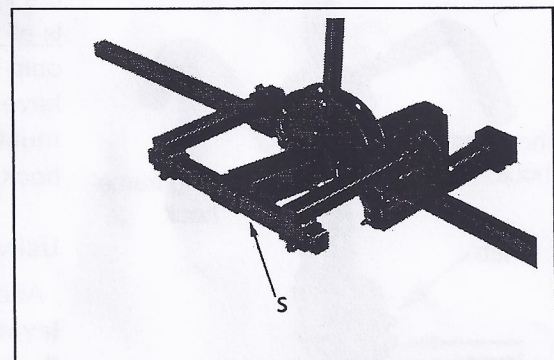
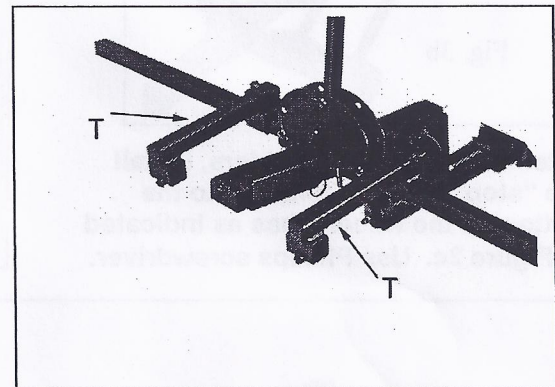
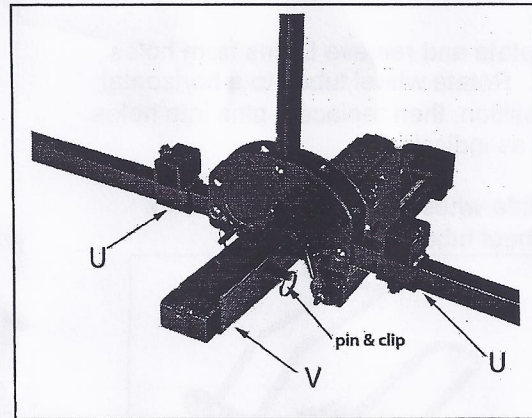

Step 3: Install Wheel Holders:

Rotate and remove L pins from holes A. Rotate wheel tubes to a horizontal position, then replace L pins into holes B as indicated.

Slide wheel Holders E and F onto wheel tubes as indicated.

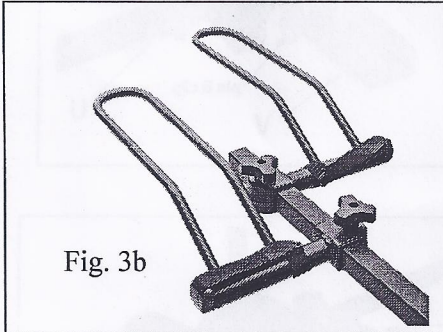

After installing wheel holders, install the "stop" screws (item P) into the bottom of the wheel tubes as indicated in Figure 2c. Use Phillips screwdriver.

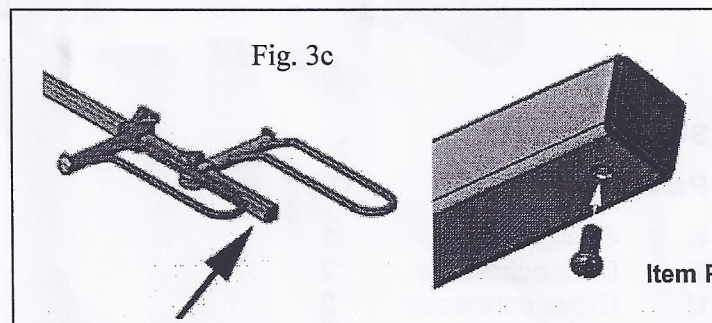
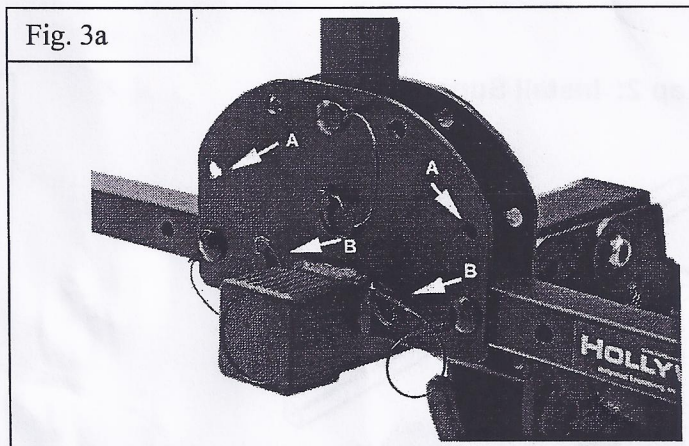

Step 4: Installation and operation of Clamp System

Position the long frame hook on top of the round vertical post facing the vehicle. Squeeze the lever and the tab together, so that the lever is all the way up (engaged). Now wiggle the plastic housing down onto the tube aligning the index guides with the index slots. You may have to gently tap it with your other hand. Remember the lever must be engaged to install it onto the tube. Repeat for the short hook facing in the opposite direction.

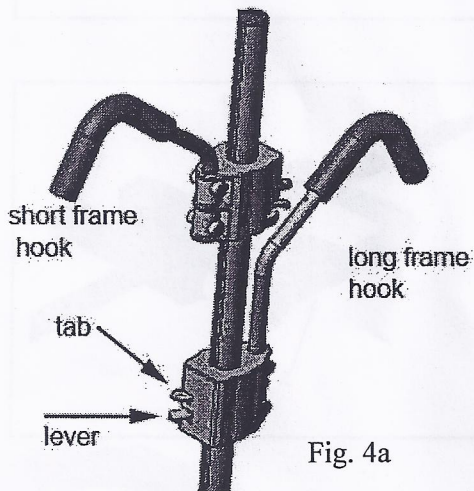

Using the clamps:

After the clamp is installed, it can only be raised by engaging the lever. The clamp can physically be pushed down without engaging the lever but it is highly recommended that the lever also be engaged when lowering the clamp.

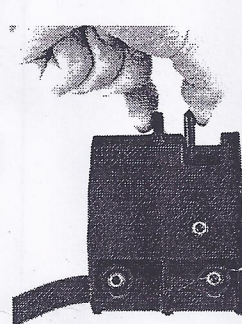
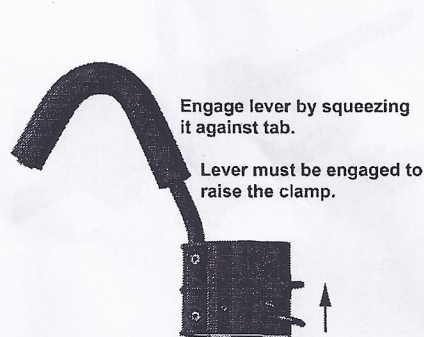

Step 5: Fold Up and Tilt Down features

To fold up the main beam, you must first fold down the vertical post (B). Refer to Fig. 3a: Rotate and remove pin A, then rotate the post (B) and replace the pin in either holes C.

Next, refer to Fig. 3a: remove clip R from pin H6, then remove pin H6.

Finally, rotate main beam upward and re-install pin H6 and clip into hole H2 per Fig. 3a

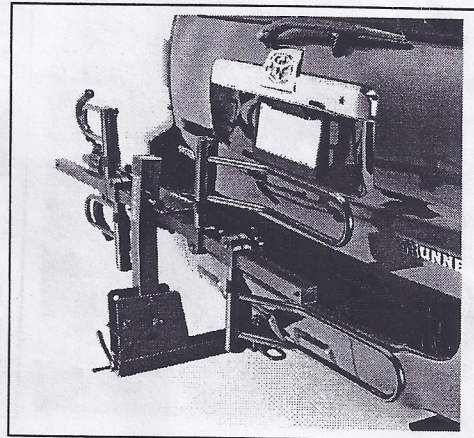

Tilt –Down Feature:

For easy access to the rear cargo door of your vehicle, the Sport Rider can be tilted down: First fold down vertical Post as described in "Fold-up feature". Next refer to fig. 1a: Remove pins H5 then H6 from receiver tube bracket and gently lower the main beam down so it is resting on the welded stop.

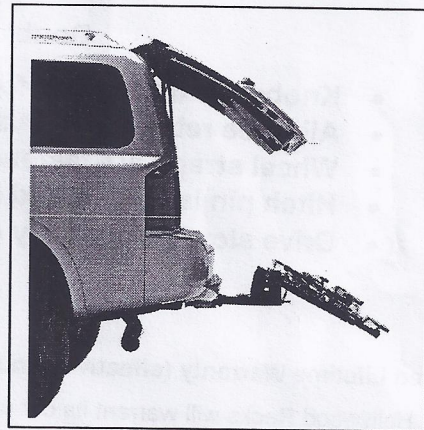

Step 6: Installing bikes on the rack

The bikes should always be positioned so that the lowest point on the bike frame's top tube is close to the vertical post (Fig. 6b).

The bike handlebars should be staggered (first bike's handlebars on passenger side, second bike's handlebars on driver side, etc.

1. Lower both vertical posts as described earlier.
 2. To adjust the bike's wheels trays, loosen the knobs and slide wheel holders along the wheel support tube so that they are positioned directly beneath each wheel. Try to adjust the position of the wheel trays so that the hook will rest on the bike's lowest point of the top tube (Fig. 6b) Tighten knobs securely. Rotate the bike's pedals so that the vertical post can be raised and secured. Slide the hook down onto the frame. Use the Velcro strap on the wheel holder.
 3. Adjust the wheel holders of the second bike and mount to the rack in the same procedure as described above.
 4. Be sure that the hooks are well supported on the bike's frame and the knobs securely pushing down on the bike's frame. **Tips for carrying woman's bikes and bikes with slanted top tubes: Adjust the wheel trays so that the hook will rest in the bike frame's top tube and seat tube.**
- A keyed trailer hitch pin and security cable is included to help prevent theft of rack and bikes.*

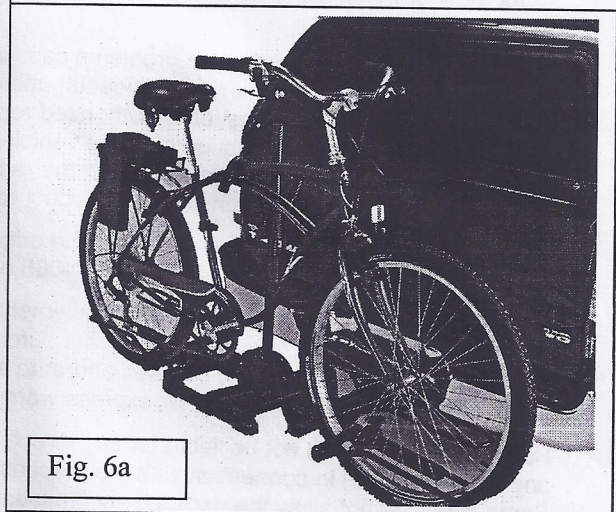

Fig. 6a

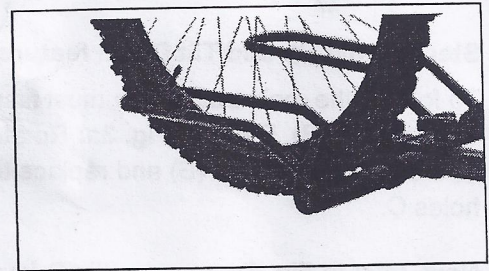
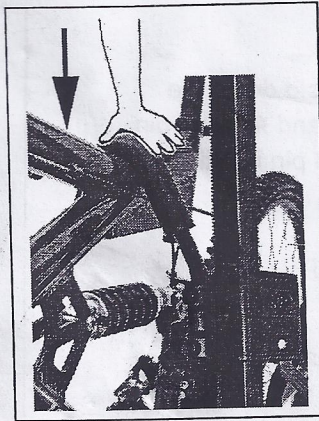
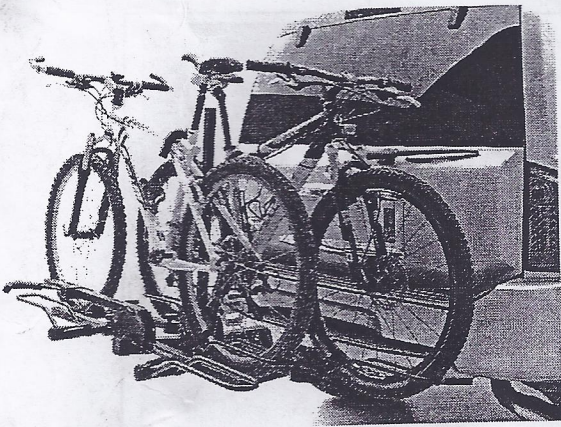

Fig. 6b

Fig. 6c

Double check before driving off:

- Knobs are tight on all four wheel trays and both frame hooks.
- All three retaining pins are properly inserted and secure
- Wheel straps are fastened
- Hitch pin is secure and hitch pin clip is installed
- Drive slowly on bumpy or dirt roads

Limited Lifetime Warranty (effective January 1, 2008):

Hollywood Racks will warrant its car racks and accessories during the time that an original retail purchaser owns the product subject to the exclusions and limitations of this warranty. Hollywood Racks will remedy defects in materials and workmanship by repairing or replacing (at its option) a defective part without charge for labor or parts. Hollywood Racks may elect (at its option) to issue a refund equal to the purchase price paid for the product.

This warranty does not cover problems caused by normal wear and tear including (but not limited to) weather, scratches, dents, rust, accidents, unlawful vehicle operation, misuse, abuse, neglect, theft, unauthorized modifications, or unauthorized repair. No warranty is given for defects resulting in incorrect assembly, incorrect installation onto the vehicle, installation on a "no fit" vehicle, incorrect attachment of bicycles onto the rack, or overloading of the rack's weight restrictions. This warranty terminates if the original retail purchaser transfers the product to any other person.

If a product is believed to be defective, the original retail purchaser should contact either the original retailer or Hollywood Racks directly at 800-747-4085 or at info@hollywoodracks.com

Disclaimer of Liability: Repair or replacement of a defective product or the issuance of a refund or credit (as determined by Hollywood Racks) is a purchaser's exclusive remedy under this warranty. Damage to a purchaser's vehicle, cargo, bicycles and or to any other person is excluded. This warranty is expressly made in lieu of any and all other express warranties, whether oral or written.

Hollywood Racks shall not be liable for any direct, indirect, consequential, incidental, special, punitive or any other damages in connection with the purchase, use or handling of this product. Some states do not allow the exclusion or limitation of consequential or incidental damages and the above limitation may not apply to you. This warranty gives you specific legal rights and you have other rights, which vary from state to state.

Hollywood Racks
12812 South Spring Street Los Angeles, CA 90061
(800) 747-4085 (310) 516-8600 Fax (310) 516-8955
Customer Service Hours: 8:00 AM- 3:00 PM Pacific Time M-F
www.hollywoodracks.com info@hollywoodracks.com