

# Hollywood Racks - Sport Rider Recumbent Bike Hitch Rack

Model HR1000Z-R: 2 Bike Capacity, fits both 1 1/4" and 2" hitch receivers

Includes locking frame hooks and keyed alike locking hitch pin

Not to be used on any trailer, fifth wheel or towed vehicle Weight Limit 50 lbs/22.5 kg per bike

## PARTS LIST

Item	Description	Qty
A	Vertical post	1
B	Support beam	1
C	Wide ratchet hook	1
D	"Z" ratchet hook	1
E	Left wheel holder	2
F	Right wheel holder	2
G	Folding bracket	1
H	Hitch receiver tube	1
I	Velcro wheel straps	4
J	Wheel tubes	2
K	Knob for wheel holder	4
L	L-Pin	1
M	1 1/4"-2" adapter	1
N	Tube stop screws	3
O	Wheel tube hardware	4
P	Hitch bolt hardware kit:	
	Hitch pin bolt	1
	Flat washer	1
	Lock washer	1
	Lock Head	1
Q	Hardware bag including:	
	1/2" diameter bolt	1
	1/2" lock nut	1
	1/2" steel washers	2
	Hex wrenches	2
	(8mm & 5mm	
	10mm Carriage bolts	4
	10mm lock nuts	4
	Thick washers	4
R	Keys	2
S	Small Wheel Adapter	2

Fig. 1

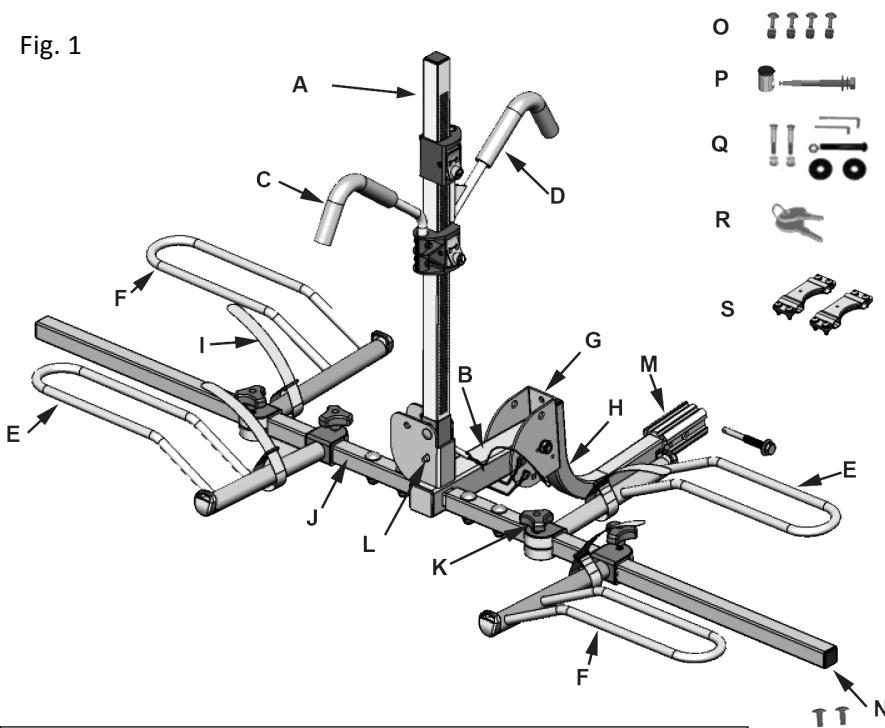

**Assembly: Tools required: adjustable wrench or equivalent (3/4" or 19mm and 1/2" or 13mm), 5 & 8mm Hex wrench included.**

**Step 1:** Slide wheel tube (J) over post, square holes facing up per Fig. 2 Install wheel tube hardware (O) per Fig. 3

Fig. 2

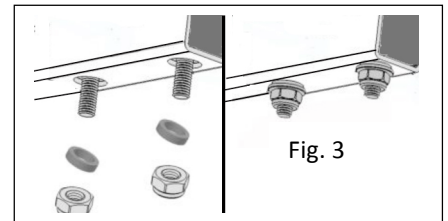
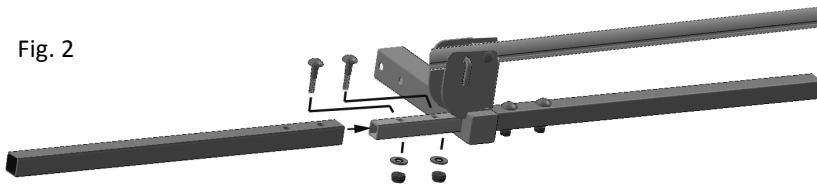

Fig. 3

Per Fig. 4, Slide the receiver tube's bracket (G) onto the support beam (B). Be careful not to dislodge the two pre-installed plastic spacers. Align the outer holes and install the attached snapper pin and clip. Next, align the inner holes and install the 1/2" bolt and washer (Q). Rotate the rack upright, and install the nut and washer onto the bolt.

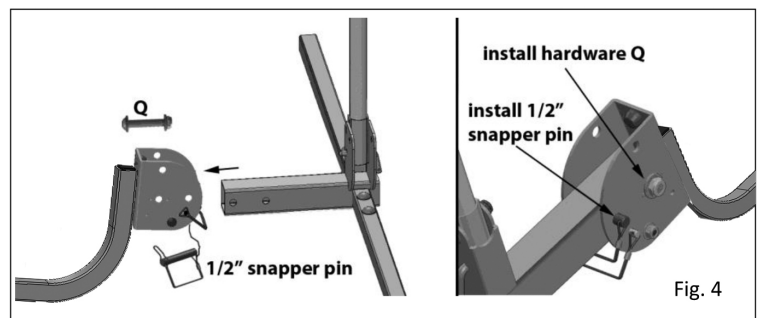
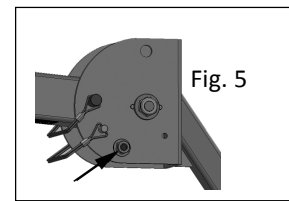

Fig. 4

Next refer to **Fig. 5**: Adjust tightness on indicated nut using adjustable wrench (or either ½" or 13mm) so that the support beam fits snug inside the folding bracket. Do not over tighten or the fold up feature will be difficult to use.



**Step 2: Installing the ratcheting frame hooks**

Remove the L Pin (item L) from the front bracket and rotate the aluminum post to the vertical, or "in use" position. Insert the L pin in the lower hole per Fig. 6 & 7. Be sure release buttons on the ratchet hooks are in the unlocked position per Fig. 8. Next, position the long frame hook on top of the square post (A) with the hook facing the vehicle. Push the release button in and slide the frame hook down onto the post. Remember, the release button should be pushed in when installing the hook onto the post. Repeat for the short hook facing in the opposite direction, per Fig. 10

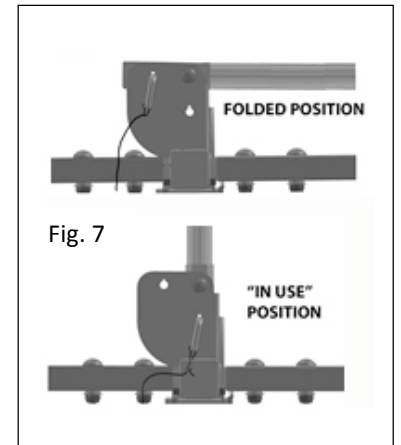
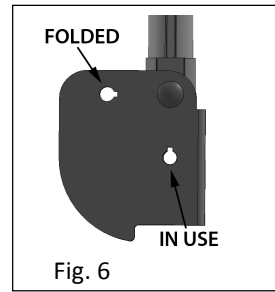

**Using the clamps:** Once the clamp is installed, it can only be raised by pushing in the release button. To lock the frame hook, insert the key and rotate clockwise, per Fig. 9

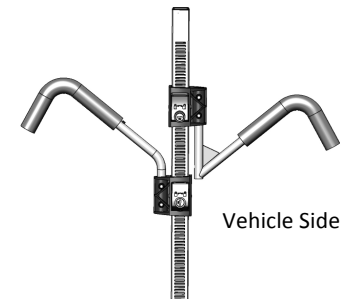
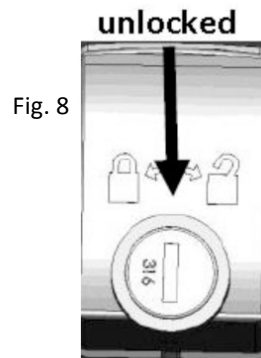

**Tip: Push down on the plastic housing, not the metal hook.**

Optional post stop screw: **Per Fig. 10A**, if you do not need to remove the frame hooks for bike installation, install screw **N** into post with Phillips screwdriver.

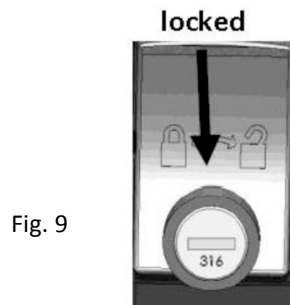

Fig. 10

**Step 3: Install Wheel Holders**

Loosen the knobs on the wheel holders and slide them onto the wheel tubes per Fig. 11. **They are snug - you may need to tap them on.** Configure the wheel holders per Fig. 12. Install the wheel holder for inside bike passenger side first (1), next the outside bike passenger side (2), then the inside bike's driver side (3), and finally the outside driver side wheel holder (4).

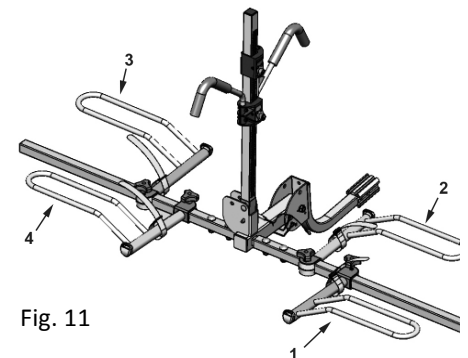
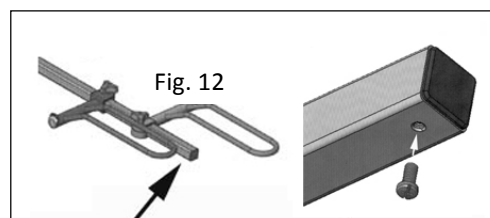

Fig. 10A

Fig. 11

**Step 4: Installing wheel holder stop screws:**

After determining the final position of the wheel holders, install the two stop screws (N) into the bottom of the wheel tubes as indicated in Fig. 12. Use Phillips screwdriver.



### Step 5: Fold up and tilt down functions

#### *Folding up when rack is mounted on vehicle:*

Rotate and remove the center L-Pin (L) per Fig. 6, then rotate the vertical post to the vertical position. Next, refer to Fig. 13: Remove the ½" snapper pin, rotate support beam upwards then re-attach snapper pin into the upper hole.

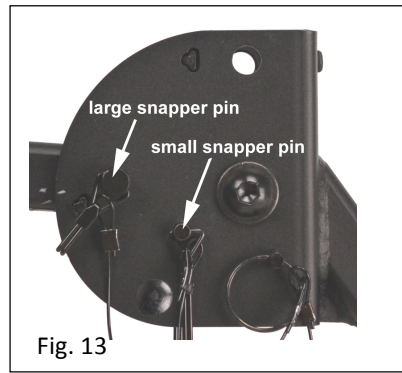

#### *Tilting down for vehicle cargo area access:*

Per Fig. 13, Remove the large (½") snapper pin. Next, remove smaller snapper pin and gently lower the support beam while holding rack up.

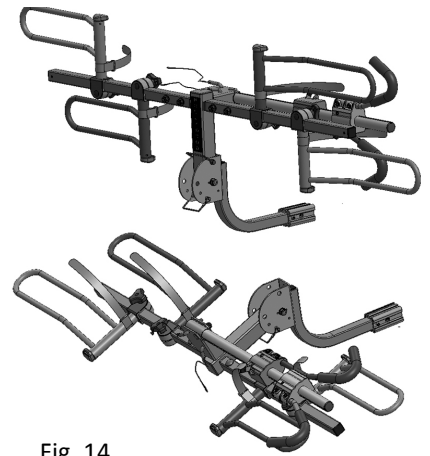
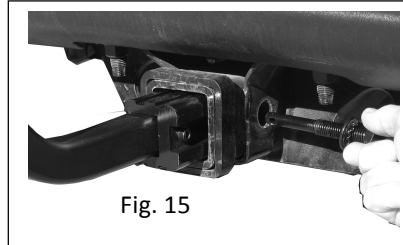

**Step 6: Installation into the hitch:** Insert the hitch receiver tube **H** into the trailer hitch and align the holes per Fig. 15. Place the lock washer and then the flat washer onto the hitch pin bolt **P**. Next, insert and tighten the bolt using a ¾" socket wrench or equivalent. Tighten securely. Next, per Fig. 15A, install the lock head onto the end of the hitch pin and be sure to remove the key. Note for 2" hitches: the bolt should pass through the aluminum spacer first, then through the receiver tube.

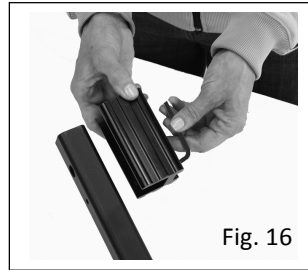

#### **Use with 1 ¼" hitches:**

If the rack is to be used on a 1 ¼" hitch, remove the aluminum spacer block from the receiver tube with the included 5mm hex wrench per Fig. 16.

**Small Wheel Adapter:** For bikes with 16" wheels, use the "small wheel" adapter (item S) to prevent the wheel from falling through the wheel holder. Place the upper section on top of the wheel holder, the position the bottom section directly below it. Insert the bolts and tighten using the included 5mm hex wrench. Slide the wheel adapter to the desired position then tighten all 4 bolts securely.

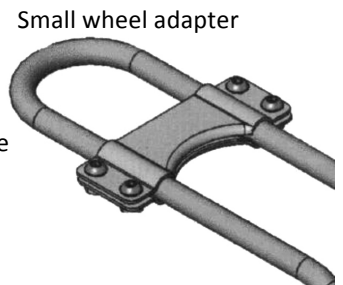

### Step 7: Installing bikes on rack

**Carrying one bike:** Place the bike in front of the rack and slide the outside wheel holders so they align with the bike's wheels. **Try to locate the wheel holders so that the frame hook will rest near the bike's lowest point of the top tube.** Place the bike onto the wheel holders and make final wheel holder position adjustments if necessary. Tighten knobs securely. Push the frame hook down onto the bike's frame until fully engaged per Fig. 17, the padded hook should be snug and touching onto the frame, do not over compress. Push down on the plastic housing, not the metal hook. Tighten the Velcro straps **I** around the bike's wheels per figure 18. As the final step, pull up on the plastic housing to double check it is properly engaged and lock the ratchet clamp for security.

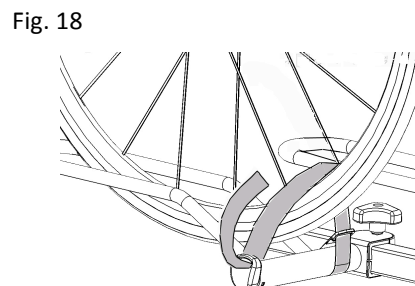

**Carrying two bikes:** When carrying two bikes, the handlebars must be staggered. Depending on the size of the bikes and the length of their wheel bases, the location of the wheel holders will vary. Place the inside bike in front of the rack. Loosen the knobs **J** on the inside wheel holders and slide the wheel holders so they align with the bike's wheels. **Try to locate the wheel holders so that the frame hook will rest near the bike's lowest point of the top tube.** Place the bike onto the wheel holders and make final wheel holder position adjustments if necessary. Tighten knobs securely. Push the frame hook down onto the bike's frame until fully engaged per Fig. 17. Push down on the plastic housing, not the metal hook. Tighten the Velcro straps **I** around the bike's wheels per Fig. 18. As the final step, pull up on the frame clamp to double check it is properly engaged. Repeat for the outside bike, positioned with the handlebars on the passenger side. Lock ratchet hooks for security.



### **Trike Adapter Accessory (sold separately)**

Trike Adapter Model 1: Allows the carrying of one trike on the rack



#### **Double check before driving:**

- Knobs are tight on all four wheel holders
- Velcro straps are securely fastened
- Weight limit 50lbs/22.5 Kg per bike
- Frame hooks are firmly pressed down onto bike frame.
- Drive slowly on bumpy or dirt roads
- All hardware is securely fastened

### **This product is not to be used on any trailer, fifth wheel or towed vehicle**

#### **Limited Lifetime Warranty (effective January 1, 2008):**

Hollywood Racks will warrant its car racks and accessories during the time that an original retail purchaser owns the product subject to the exclusions and limitations of this warranty. Hollywood Racks will remedy defects in materials and workmanship by repairing or replacing (at its option) a defective part without charge for labor or parts. Hollywood Racks may elect (at its option) to issue a refund equal to the purchase price paid for the product. This warranty does not cover problems caused by normal wear and tear including (but not limited to) weather, scratches, dents, rust, accidents, unlawful vehicle operation, misuse, abuse, neglect, theft, unauthorized modifications, or unauthorized repair. No warranty is given for defects resulting in incorrect assembly, incorrect installation onto the vehicle, installation on a "no fit" vehicle, incorrect attachment of bicycles onto the rack, or overloading of the rack's weight restrictions. This warranty terminates if the original retail purchaser transfers the product to any other person. If a product is believed to be defective, the original retail purchaser should contact either the original retailer or Hollywood Racks directly at 800-747-4085 or at [info@hollywoodracks.com](mailto:info@hollywoodracks.com) **Disclaimer of Liability:** Repair or replacement of a defective product or the issuance of a refund or credit (as determined by Hollywood Racks) is a purchaser's exclusive remedy under this warranty. Damage to a purchaser's vehicle, cargo, bicycles and or to any other person is excluded. This warranty is expressly made in lieu of any and all other express warranties, whether oral or written. Hollywood Racks shall not be liable for any direct, indirect, consequential, incidental, special, punitive or any other damages in connection with the purchase, use or handling of this product. Some states do not allow the exclusion or limitation of consequential or incidental damages and the above limitation may not apply to you. This warranty gives you specific legal rights and you have other rights, which vary from state to state.

#### **Hollywood Racks**

12812 South Spring Street Los Angeles, CA 90061 (800) 747-4085 (310) 516-8600 Fax (310) 516-8955  
Customer Service Hours: 8:00 AM- 3:00 PM PST [www.hollywoodracks.com](http://www.hollywoodracks.com) [info@hollywoodracks.com](mailto:info@hollywoodracks.com)  
Made in Taiwan

HR1000Z-R V2.2 092518