

The F2 Over-the-Top rack has been specially designed to fit SUVs, mini-vans and hatch-backs equipped with rear spoilers or wind deflectors. The rack uses an adjustable "spoiler clearance frame" to prevent the top or uppermost straps of the rack from making contact with the spoiler. The F2 will also fit most vehicles without spoilers.

**When installing the F2, please follow these important guidelines:**

- Install the F2 on structurally sound trunks, hatches, roof rack load bars and roof rack raised side rails only.
- Never attach hooks to plastic, glass, fiberglass or carbon fiber.
- Clean the surface of the trunk or hatch before installation of the rack.
- Tighten all six straps before AND after mounting bikes on the rack.
- **Maximum capacity is 2 bikes (F2-2) or 3 bikes (F2-3), 35 lbs/16kg per bike.**
- Always use the safety strap after loading and tying down bikes.
- Keep bicycle tires min. 1ft / 30cm away from vehicle exhaust pipe.
- Check rack, bikes and straps regularly during use.
- Drive slowly when used on bumpy or dirt surface roads.

For quick-start instructions, scan QR Code or go to [hollywoodracks.com/f2](http://hollywoodracks.com/f2)



### 1. Choosing the correct top straps

This rack includes three types of top or upper strap attachment systems:

a) Regular Hollywood top straps with trunk lid hooks (Fig. 3). These are pre-assembled with the rack. **See section 2**

b) Hatch anchors with quick connect straps. **See section 3**

c) Roof rack adapter straps with quick connect straps. **See section 4**

On some vehicles, more than one top strap attachment system can be used. Determining the best one may require ruling out the other two.

*Continued on page 2*

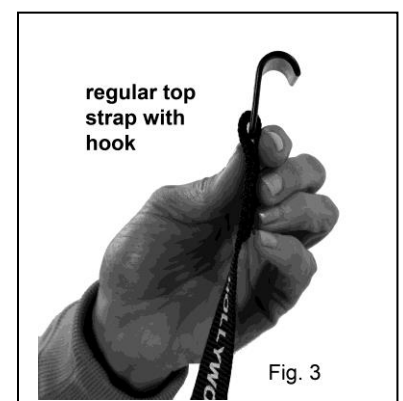
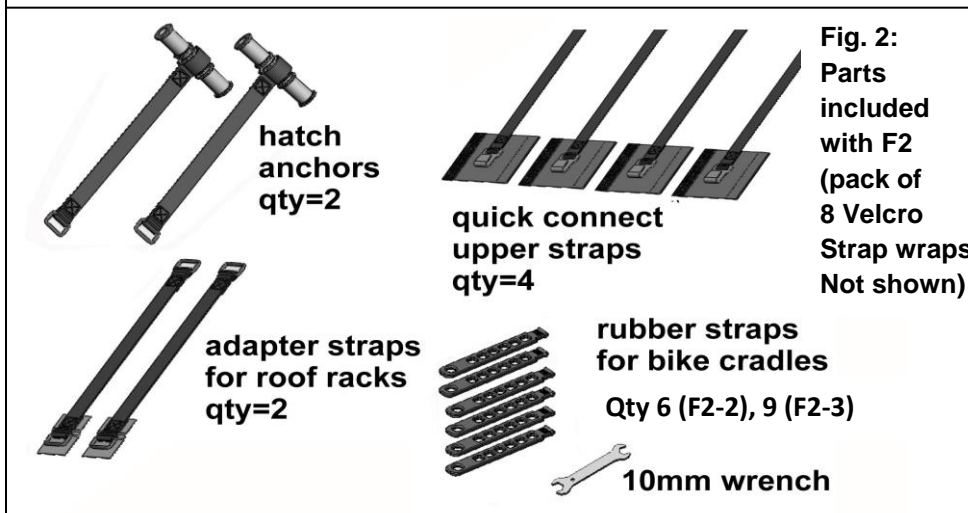
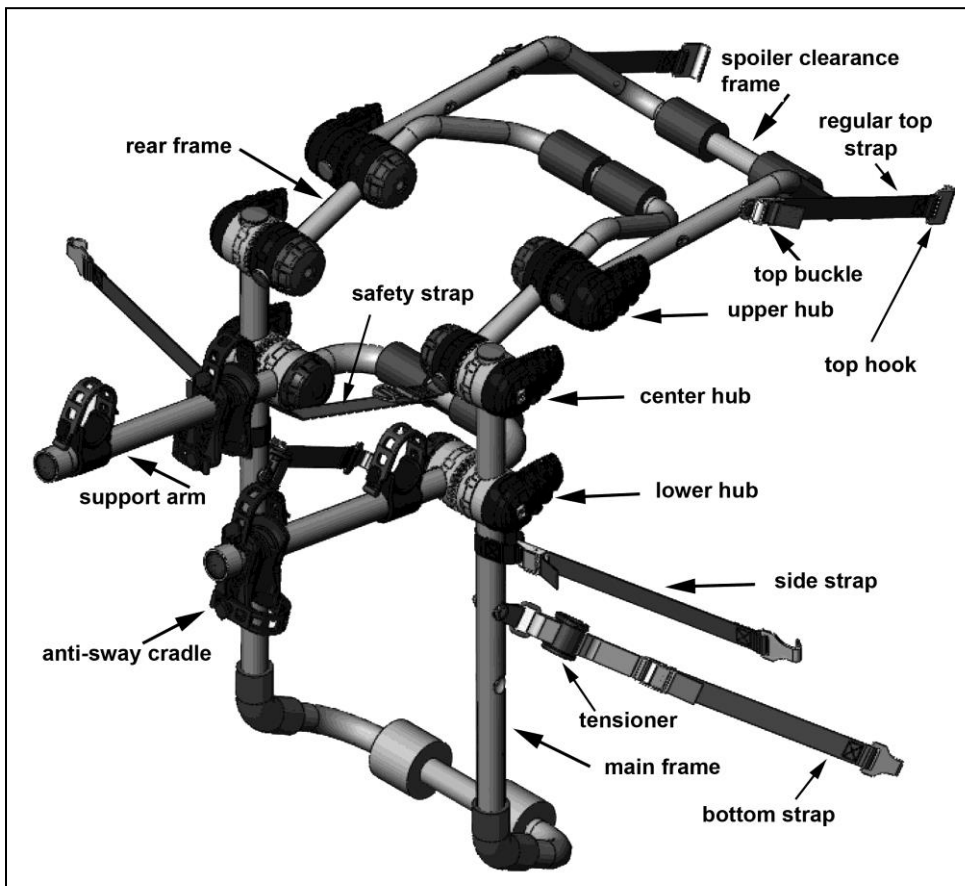

**Section 1 continued:**

Look at the gap or opening between the top of the rear hatch and vehicle.

**d) Check and confirm the following:**

I) The trunk or hatch lid made of steel. Use a magnet and check fit guide.

II) There is room for the hook to “drop” into the gap.

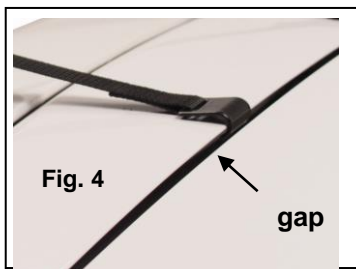

III) The hook can attach to the hatch lid. (The hatch doors on some vehicles, like the 2013 Ford Escape, are too thick for a hook to attach to).

IV) Open the vehicle’s rear hatch. There should be no plastic molding that would interfere with the hook. *Note: The hook must not attach to the spoiler. Do not use the standard upper strap if the vehicle’s spoiler is made of plastic or fiberglass.*

**If these can be confirmed, then you can use the regular upper straps with hook. If not, go to section 3 or 4.**

## 2. Installation Using Regular Upper Straps

The F2 has three sets of adjustment hubs: Lower, center and upper. The hubs are unlocked by opening the lever. They are adjusted by tightening/loosening the cup and lever. See Fig. 5

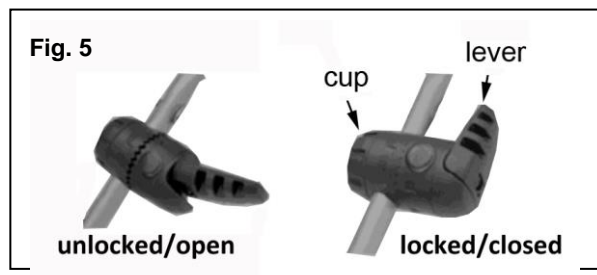

a) Unlock the center hubs (Fig. 6) and rotate the rear frame so it is vertical per Fig. 7.



Fig. 6

**Note: depending on the tightness of the cups, you may also need to unlock one or both of the levers on the lower hubs.**

b) Next, unlock the upper hubs and rotate the spoiler clearance frame so it is positioned per Fig. 8. Now lock the upper hubs.

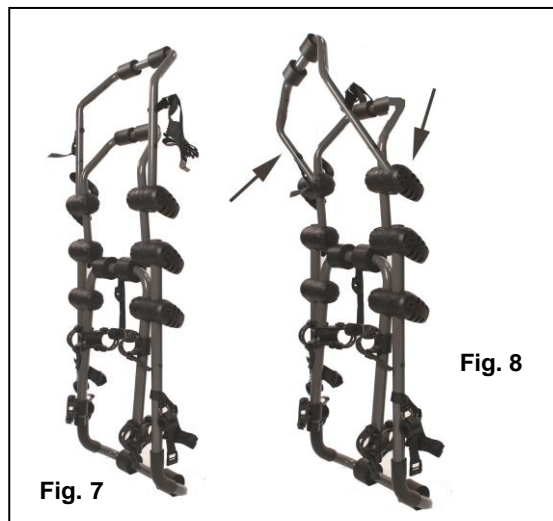

c) Place the rack on the car’s bumper and unlock the center hubs per fig. 9. Rotate the rear frame so it is resting on the car’s hatch door or window per fig 10. (Avoid contact with rear windshield wiper). **Close the levers. Note: depending on the tightness of the hubs, you may need to unlock one or both of the levers on the lower hubs.**

d) Attach the side hooks per Fig. 10. Pull the strap end to tighten. The rack should now be self supporting.

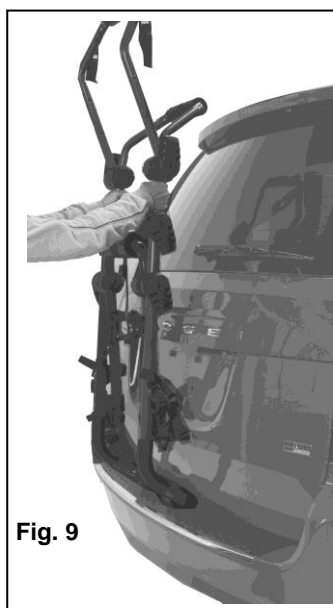
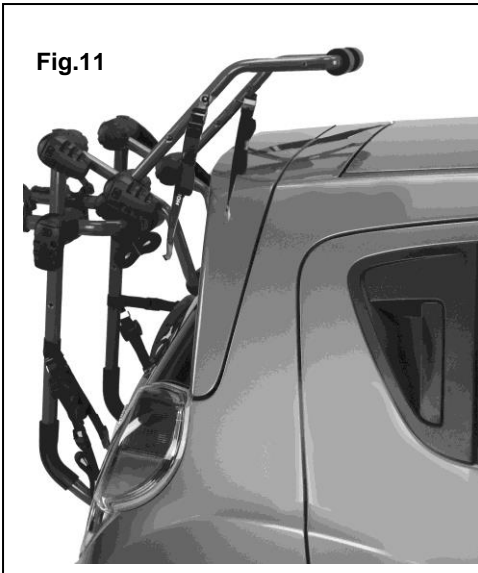

Fig. 9

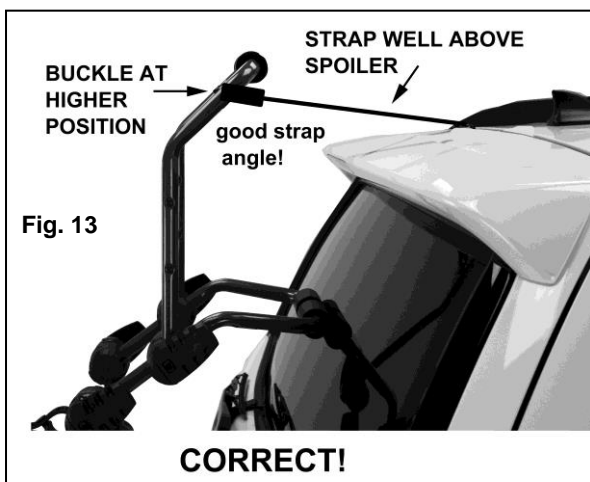
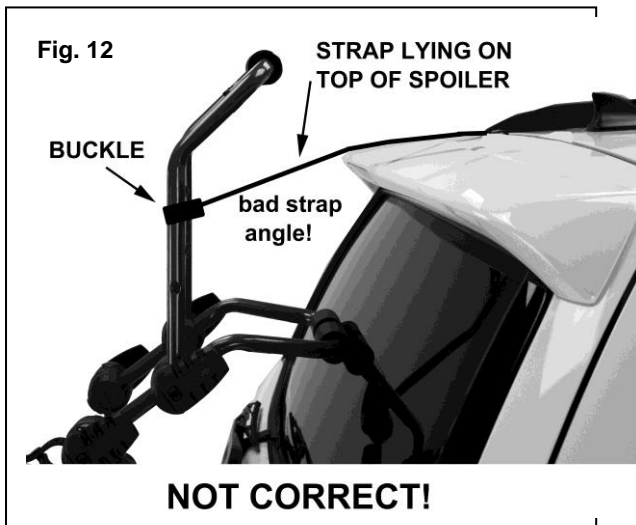

Fig. 10

e) Unlock the upper hubs and rotate the clearance frame so the upper buckle is **well above the spoiler** per Fig. 11. Close the levers.



f) Depending on the height of the vehicle, you may **not** be able to rotate the clearance frame high enough above the spoiler for a correct “strap angle” (Fig. 12). In that case, you can re-locate the upper buckles to get the correct strap angle. There are additional buckle hole positions located on the spoiler clearance frame. Use the 10mm wrench included with the rack (or equivalent) to relocate the buckles if necessary. See Fig. 13



**The strap angle from the upper-most buckles to the upper hooks must be high enough so that the straps are not making any contact with the spoiler!**

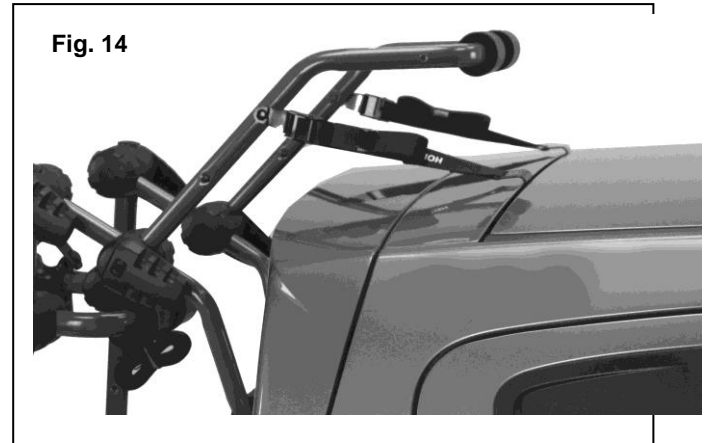

g) Attach the hooks to the hatch lid and pull the strap end snug. See Fig. 14. Lower pads should remain seated against bumper.

h) Attach the hooks on the lower straps to the bottom of the trunk or hatch lid and pull snug. See Fig. 15a.

Note that the lower strap's buckle can be relocated to the higher hole on the main frame if required. Use the 10mm wrench included with the rack. **Recheck all straps to make sure they are snug.**

i) Unlock the center hubs and rotate the support arms so they are horizontal or pointing slightly upwards, then lock hubs. See Fig. 15b.

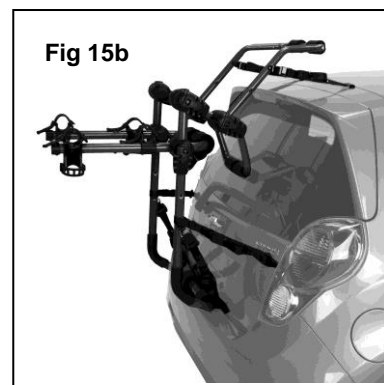
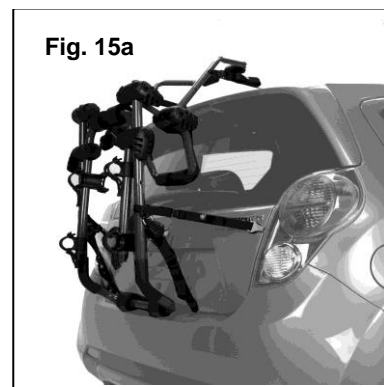

### 3. Installation Using Hatch Anchors

The hatch anchors included with the F2 (Fig. 16) fit between your rear hatch and vehicle body. They are used when the hooks on the regular straps can't be used. *If your vehicle has a roof rack with load bars or raised side rails, you may have to choose between the hatch anchor or roof rack attachment system.* There are some vehicles (such as the Infiniti J35) which will require the hatch anchors to be used in either the side strap or bottom strap position. Hatch anchors must be used with the quick connect upper straps.



#### Installation on vehicle

**a)** Remove the regular upper straps from the upper-most buckles and replace with the quick connect straps (Fig 17). Insert the strap through the bottom of the buckle while depressing the buckle's spring loaded tab. Hooks should be facing up.



**b)** Open rear hatch and insert hatch anchor's strap with D-ring through the gap/opening. The D ring is plastic coated and can lay on the car's roof. See Fig. 18 & 19.

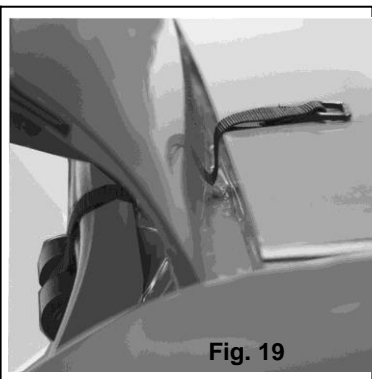
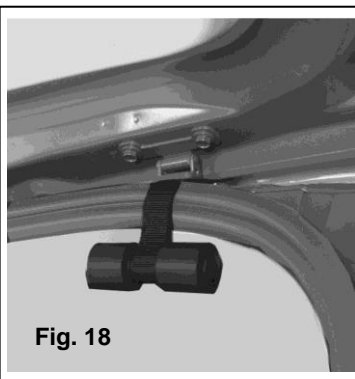

**c)** Close the rear hatch. Pull the D-ring end to remove slack out of strap. See Fig 20.



**d)** Please refer to above instructions 2a through 2f for positioning rack on vehicle

**e)** Position hook near the D-ring (Fig. 21), then connect D-ring to hook. (Fig. 22)

**f)** Tighten strap by pulling on strap end. Fold the cover over the hook/D-ring and close up the cover. (Fig. 23). Lower pads should remain seated against bumper.

**g)** Attach the hooks on the lower straps to the bottom of the trunk or hatch lid and pull snug. See Fig. 15a. Note that the lower strap's buckle can be relocated to the higher hole on the main frame if required. Use the 10mm wrench included with the rack. **Recheck all straps to make sure they are snug.**

**h)** Unlock the center hubs and rotate the support arms so they are horizontal or pointing slightly upwards, then lock hubs. See Fig.15b.

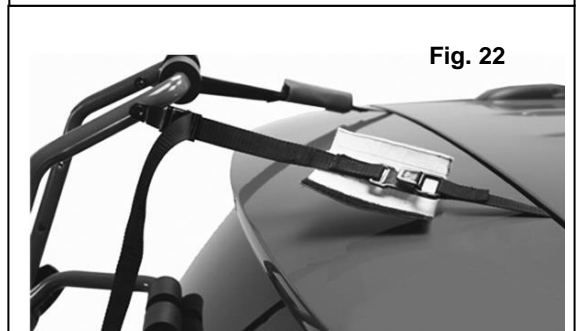
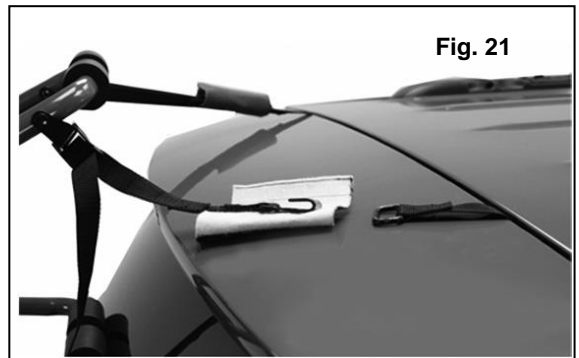

## 4. Installation Using Roof Rack Adapter Straps

These padded straps provide a convenient location for top strap attachment when regular upper straps or hatch anchors can't be used. They wrap around the raised rails or load bar and must be used with the quick connect upper straps. **There are vehicles (i.e. Infiniti J35/7) where hatch anchors are used for the bottom or side straps and roof rack adapter straps are used for the upper attachment system.**

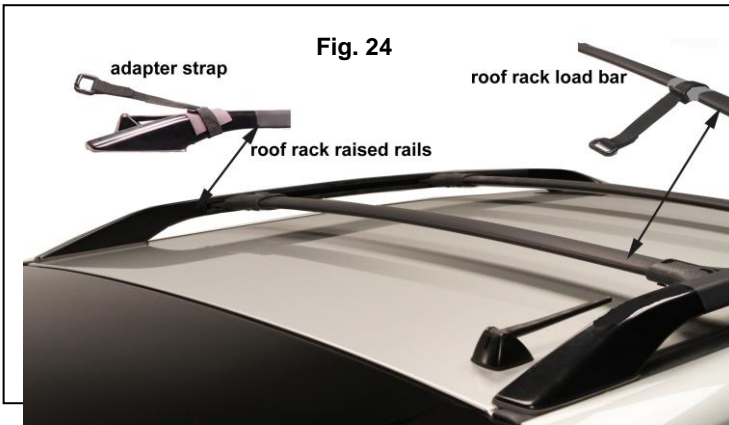

### Installation on vehicle:

**a)** Rotate the “hook side” D-ring 90 degrees so it is “length wise” in line with the strap per fig 25. Wrap the D-ring strap around the load bar or raised rail. **Insert the hook side D-ring through the padded side D-ring and pull so it is snug.** Be sure the pad is between the strap and load bar or raised rail per fig. 26. **Then rotate the hook side D-ring back to its original position.**

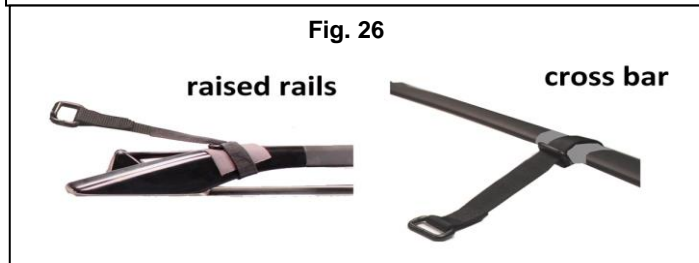
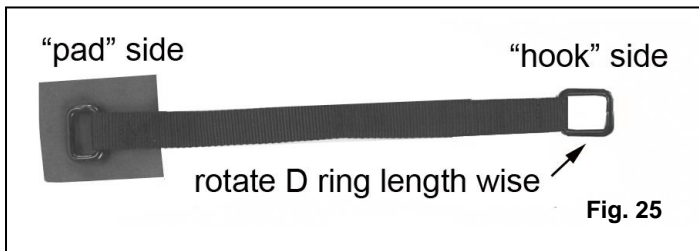

**b)** Remove the regular upper straps from the uppermost buckles and replace with the quick connect straps (Fig 27). Insert the strap through the bottom of the buckle while depressing the buckle's spring loaded tab. Hooks should be facing up.



**c)** Please refer to above instructions 2a through 2f for positioning rack on vehicle

**d)** Position hook near the D-ring then connect D-ring to hook. (Fig. 28a)

**e)** Tighten strap by pulling on strap end. Fold the cover over the hook/D-ring and close up the cover. (Fig. 28b). Lower pads should remain seated against bumper.

**f)** Attach the hooks on the lower straps to the bottom of the trunk or hatch lid and pull snug. See Fig. 15a. Note that the lower strap's buckle can be relocated to the higher hole on the main frame if required. Use the 10mm wrench included with the rack. **Recheck all straps to make sure they are snug.**

**g)** Unlock the center hubs and rotate the support arms so they are horizontal or pointing slightly upwards (Fig. 15b). Then lock hubs.

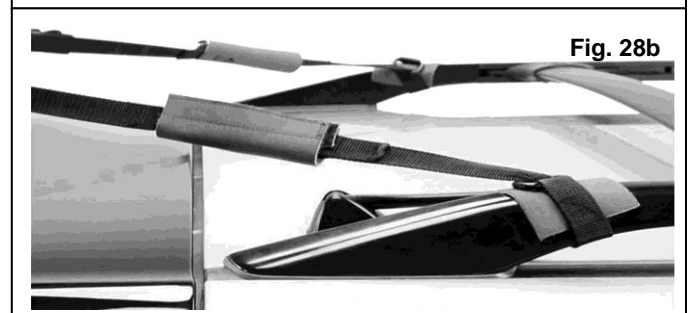

## 5. Mounting bikes on rack



Included with the rack are rubber straps (1 each for the regular cradles (Fig. 30) and 2 each for the anti-sway cradles (Fig. 31) plus one built in nylon safety strap with buckle.

Attach one end of the rubber straps to the rubber cradles (Fig. 30 & 31). Start with the round (end) hole of the strap stretched over the diamond shaped anchor on the cradle.

Place the **heaviest bike onto the rack first** (closest to the vehicle), putting the bike's top tube (usually) into the rubber cradles on the support arms. Be sure to note the location of the pedal, as you may have to rotate the crank in order to keep the pedal from hitting the vehicle.

Pull the rubber strap across the bike's frame tube and attach it to the anchor on the opposite side of the cradle for both right and left cradles. Straps should be snug, but *do not over-tighten* the straps since this may shorten the useful life of the strap.

Next, rotate the Anti-Sway cradle so that it rests against the bike's seat tube (this is the frame tube into which the seat post fits) Fig. 32a (preferred) or 32b (when frame clearance is an issue). Pull the strap across the bike's seat tube in a similar snug manner.

Put the next bike on the rack with the handlebars on the other side of the vehicle and attach the straps. Be sure **not** to route straps over any cables (Fig. 33a), but rather under them (Fig. 33b). This will protect the bike's finish.

**Once all the bikes are mounted and all the rubber straps are pulled snug (but not over-stretched), route the attached safety strap around all the bikes and re-attach to the buckle. Remember to re-check all straps after the bicycles have been mounted. Re-tighten straps as necessary.**

**SPECIAL NOTES:** On a bike with a slanted top tube, place top tube on rear cradle, and down tube on front cradle to keep bike as "level" as possible. For "ladies" style and non-conventional frames, it may not be possible to keep bike "level". On a road bike with a level top tube, place top tube on both cradles, with anti-sway on seat tube.



## 6. Fit Gallery

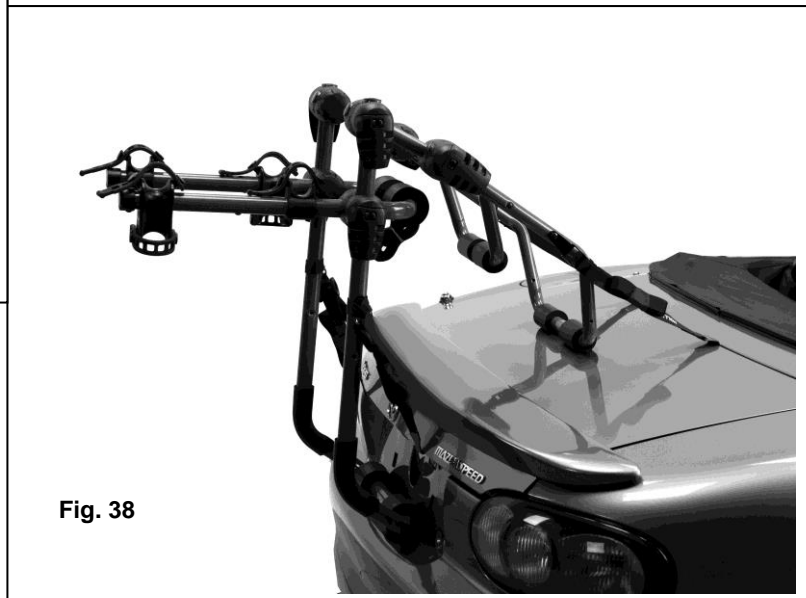
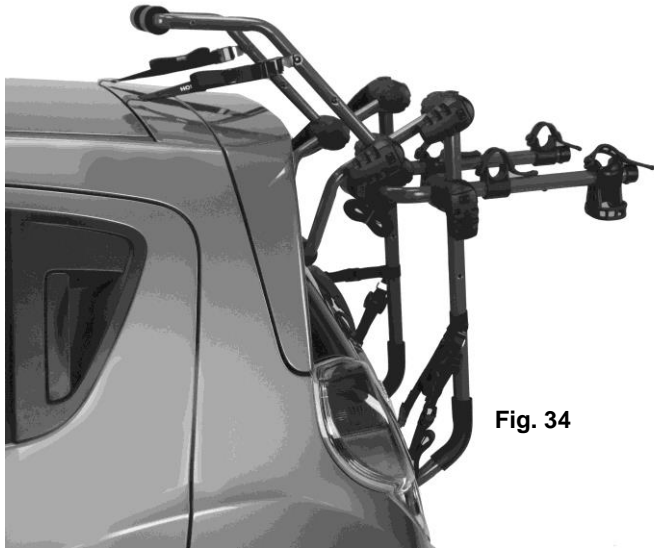

Fig. 34: Correct spoiler clearance frame position on small square back with spoiler.

Fig. 35: Correct Spoiler clearance frame position on Infiniti J35 using roof rack straps to side rails. Hatch anchors are used on bottom of hatch door.

Fig. 36: Correct Spoiler clearance frame position on Lexus RX330 using roof rack straps to side rails.

Fig. 37: Correct mounting on Dodge Caravan using Hatch anchors

Fig. 38: Installation on Mazda Miata. Rear frame and spoiler clearance frame are in-line. Spoiler frame resting on vehicle's trunk. Side straps not used on this particular vehicle.

### **CAUTION:**

*This bicycle carrier has been designed to attach securely to most vehicles. It is the user's responsibility to insure the safe and proper installation of this product. Improper attachment or installation of this product may result in damages to your bicycles, vehicle, or vehicles following behind you. If the pads of this rack (or any rack) are resting against glass or a structurally soft panel, be aware that this may cause damage to your vehicle. The manufacturer of this product will not extend the warranty to any damages not attributable to a defect in materials and workmanship. The fit guide printed in this manual is intended as a general reference only. Ongoing changes in vehicle design, materials and finishes used on motor vehicles make it the user's responsibility to determine the use of this product. Do not attach hooks to aluminum, glass, fiberglass, moldings, spoilers or carbon fiber parts. Please check the Fit Guide on the back page prior to installation! If the make and model of your cars is listed as a "No Fit," check with your dealer about installation assistance, exchange for another model that will fit, or refund. This guide is not complete due to continuous changes in automotive design. For answers to questions, call our customer service department at: 800-747-4085 Mon.-Fri. from 7:00 AM–3:00 PM Pacific time OR Email us anytime at [info@hollywoodracks.com](mailto:info@hollywoodracks.com)*

### **Limited Lifetime Warranty (effective January 1, 2008):**

Hollywood Racks will warranty its car racks and accessories during the time that an original retail purchaser owns the product subject to the exclusions and limitations of this warranty. Hollywood Racks will remedy defects in materials and workmanship by repairing or replacing (at its option) the complete rack or a defective part without charge for labor or parts. Hollywood Racks may elect (at its option) to issue a refund equal to the purchase price paid for the product.

This warranty does not cover problems caused by normal wear and tear including (but not limited to) weather, scratches, dents, rust, accidents, unlawful vehicle operation, misuse, abuse, neglect, theft, unauthorized modifications, or unauthorized repair. No warranty is given for defects resulting in incorrect assembly, incorrect installation onto the vehicle, installation on a "no fit" vehicle, incorrect attachment of bicycles onto the rack, or overloading of the rack's weight restrictions. This warranty terminates if the original retail purchaser transfers the product to any other person. If a product is believed to be defective, the original retail purchaser should contact either the original retailer or Hollywood Racks directly at 800-747-4085 or at [info@hollywoodracks.com](mailto:info@hollywoodracks.com)

**Disclaimer of Liability:** Repair or replacement of a defective product or the issuance of a refund or credit (as determined by Hollywood Racks) is a purchaser's exclusive remedy under this warranty. Damage to a purchaser's vehicle, cargo, bicycles and or to any other person is excluded. This warranty is expressly made in lieu of any and all other express warranties, whether oral or written. Hollywood Racks shall not be liable for any direct, indirect, consequential, incidental, special, punitive or any other damages in connection with the purchase, use or handling of this product. Some states do not allow the exclusion or limitation of consequential or incidental damages and the above limitation may not apply to you. This warranty gives you specific legal rights and you have other rights, which vary from state to state.

**Hollywood Racks**  
**12812 South Spring Street Los Angeles, CA 90061**  
**(800) 747-4085 (310) 516-8600 Fax (310) 516-8955**  
**Customer Service Hours: 7:00 AM- 3:00 PM Pacific Time**  
**[www.hollywoodracks.com](http://www.hollywoodracks.com) [info@hollywoodracks.com](mailto:info@hollywoodracks.com)**

Made in Taiwan  
US Patent No. 9,522,635  
**V6.3**