

When using the Hollywood Expedition rack, please follow these important guidelines:

- Install the Baja rack on structurally sound trunks and rear decks only.
- Never attach hooks to aluminum, plastic, glass, fiberglass or carbon fiber.
- Clean the surface of the trunk, rear door or deck lid before installation of the rack.
- Tighten all six straps both before *and* after mounting bikes on the rack.
- Never place more than 100 lbs. (45 KG) on either B2 or B3
- Always use the attached tie-down safety strap after loading all of the bicycles onto the rack. This final Safety Strap should be threaded through all of the bikes.
- Keep the bicycle tires at least one foot (1'=30 cm approx.) away from the exhaust pipe(s).
- Check the rack, bikes and straps regularly during use.
- Drive slowly when used on bumpy or dirt surface roads.



Fig.1

Mounting the Hollywood Baja Rack on Your Vehicle:

After removing your **Baja** rack from the box, loosen the black hubs by flipping the hub lever outward (away from the rack). This will allow the two sections of the rack frame to move relative to one another for correct rack placement on your vehicle. Note how the teeth on the hubs interlock into place. See **Fig. 2a & 2b** showing the hub and lever in both the closed and open positions.

Adjusting the rack frame: Position the **Baja** rack on the vehicle such that the bicycle support arms are parallel to the ground, or angled slightly upward at the back of the rack. The upper pads should rest on a steel trunk lid, or rear door. If necessary (particularly on vans, station wagons and SUV's) the upper pads *may rest* on glass. This is because the weight of the rack and bicycles is support by the upper straps, and the lower pads. Be careful not to interfere with rear mounted wiper blade.

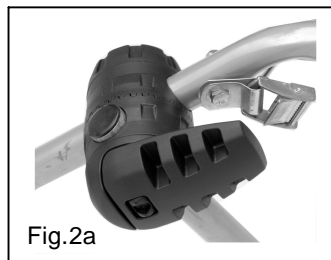

Fig.2a



Fig.2b

Once the proper rack position has been determined by adjusting the **Baja's** bicycle support arms and main frame, tighten the hubs by flipping black levers in and locking them in place against the rack; then rotate the lever and/or cup until the hubs are **snug and secure**. Be sure that the teeth of the hubs are interlocked evenly and that the support arms are parallel or pointing slightly upwards .

Attaching the straps: Begin attaching straps with the upper (farthest forward) pair, placing the hooks in the most forward trunk lid opening, and then pulling on the end of the strap until the proper length is reached. Once the upper straps have been attached, the side and bottom straps can be attached in any order.

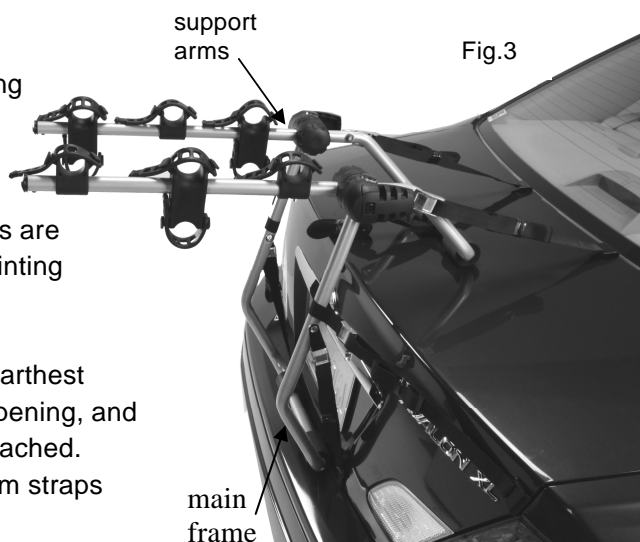

Fig.3

If your vehicle has a “soft” plastic bumper, the lower straps may be attached to the lower edge of the trunk lid, or rear door opening instead of the bumper. When all six straps are attached, pull on each strap to make sure that the hooks are properly seated, and that all straps are tight. After mounting the bikes, recheck and retighten all straps since the weight of the bike(s) often adds tension to the upper straps, and removes an equal amount of tension from the lower straps.



Fig.4



Fig.5



Fig.6

Mounting bikes on rack

Included with the rack are either 6 rubber straps for the B-2 or 9 rubber straps for the B-3. (use 1 each for the regular cradles (Fig. 5) and 2 each for the anti-sway cradles (Fig. 6) plus one built in nylon safety strap with buckle.

Attach one end of the rubber straps to the rubber cradles. Start with the round (end) hole of the strap stretched over the diamond shaped anchor on the cradle.

Place the **heaviest bike onto the rack first** (closest to the vehicle), putting the bike's top tube (usually) into the rubber cradles on the support arms. Be sure to note the location of the pedal, as you may have to rotate the crank in order to keep the pedal from hitting the vehicle.

Pull the rubber strap across the bike's frame tube and attach it to the anchor on the opposite side of the cradle for both right and left cradles. Straps should be snug, but *do not over-tighten* the straps since this may shorten the useful life of the strap.

Next, rotate the Anti-Sway cradle so that it rests against the bike's seat tube (this is the frame tube into which the seat post fits) Fig. 7 or 8. Pull the strap across the bike's seat tube in a similar snug manner. Put the next bike on the rack with the handlebars on the other side of the vehicle and attach the straps. Be sure **not** to route straps over any cables (Fig. 9), but rather under them (Fig. 10). This will protect the bike's finish.

Once all the bikes are mounted and all the rubber straps are pulled snug (but not over-stretched), route the attached safety strap around all the bikes and re-attach to the buckle. Remember to re-check all straps after the bicycles have been mounted. Re-tighten straps as necessary.

SPECIAL NOTES: On a bike with a slanted top tube, place top tube on rear cradle, and down tube on front cradle to keep bike as “level” as possible. For “ladies” style and non-conventional frames, it may not be possible to keep bike “level”. On a road bike with a level top tube, place top tube on both cradles, with anti-sway on seat tube.

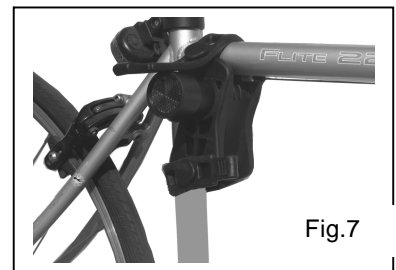

Fig.7

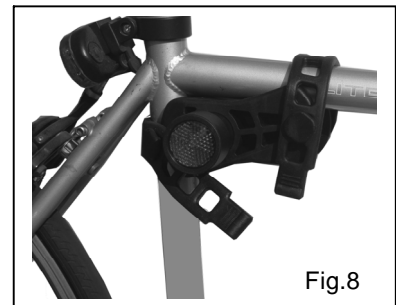

Fig.8



Fig.9



Fig.10

Esta hoja de instruccion es aplicable para 2 y 3 bicicletas capacidades en este porta bicicletas por favor Seguir las siguientes recomendaciones:

- *Se instala el porta bici. Baja en cubiertas metalicas solamente.
- *Nunca poner los ganchos al aluminio plastico, cristal, fibra de vidrio, carbon
- *Limpia la superficie de la puerta posterior o de la tapa de la cubierta antes de la instalacion del porta bici.
- *Aprieta las seis correas antes y despues que montan las bicis en el portabici.
- *Nunca poner mas de 100 libras.(45 kilogramos) en el Baja 2 o Baja 3
- *Usa siempre la correa de 86" alrededor de todas las bicis, y del marco del portabicicletas.
- *Revisar el portabici las bicis y las correas regularmente durante el uso.
- *Impulsion del vehiculo lentamente cuando esta utilizando en los caminos superficiales desiguales o de roca.

Despues de sacar tu Baja porta bici de la caja

Aflogar cubos jalando la palanca del cubo asia afuera esto permitira que las dos secciones del porta bici tengan movimiento.

Para colocacion correcta en el vehiculo ver como los dientes del cubo se enclavijan en su lugar ver fig.2a y 2b Muestran en pocision cerrada y abierta los cubos y la palanca.

Ajuste del marco

Pocision del Baja porta bici en el vehiculo. los brazos paralelos al piso o en angulo levemente asia arriba de la parte trasera del porta bici

Las espongas superiores deben reclinarsse sobre la parte superior o puerta trasera ver fig.1 particularmente en furgonetas y SUV's las espongas

Superiores pueden reclinarsse sobre el vidrio esto es porque el pesor del porta bici y las bicicletas estan apoyadas en las correas superiores y en

Las espongas de abajo .tener cuidado de no estorbar el limpiados de vidrio trasero.

Cuando la pocision del porta bici a sido determinada apriete los cubos moviendo la palanca asia dentro del porta bici asegurandolas en su lugar

Sobre el porta bici rotar la palanca asta que los cubos esten apretados y asegurados

Ver que los dientes de los cubos estan enclavijados correctamente de modo que los brazos sean paralelos

Colocar las correas .6 en total 2 para la parte de arriba 2 a los lados y 2 para abajo del bumper o orilla de la cajuela si tu vehiculo tiene bumper

Plastico colocar las correas debajo en la parte baja de la cajuela .

Colocar las correas de goma en las cunas y blockes antimovimiento

Montar las bicis en tu porta bicicletas baja.

Montar la bicicleta mas pesada primero sobre las cunas pegadas al vehiculo estar seguro que el pedal de la bici no golpea el vehiculo.

A lo major tengan que rotar el pedal .

Jalar la correa de goma sobre el tubo del marco de la bicicleta adjuntar al anclaje en el lado opuesto de la cuna en ambos lados izquierdo y Derecho de las cunas las correas apretarlas lo suficiente pero demasiado esto puede acortar la duraci3n de la correa.

Siguiente rotar el bloque anti movimiento que repose en el poste del asiento ver figura 7 o 8 Jalar la correa sobre el poste del asiento de una manera similar poner la siguiente bicicleta con el manillar en posici3n opuesta a la primera bicicleta fijar las correas estar seguro que no est3n sobre ning3n cable ver figura (9) pero puede pasarlo abajo del cable ver figura (10) esto protege el afinado de la bicicleta.

Cuando todas las bicicletas an sido montadas y todas las correas de goma est3n apretadas lo suficiente (pero no demasiado estiradas) colocar alrededor de las bicicletas la correa de seguridad que esta adjunta al marco de la bicicleta y asegurar de colocar dentro de la hebilla y apretarla .recuerda de revisar todas las correas cuando las bicicletas an sido montadas si es necesari volverlas apretar.

Nota especial: en una bicicleta con tubo superior inclinado, coloque el tubo en la parte superior trasera y asia abajo en la parte delantera para mantenerla a 'nivel' la bicicleta lo mas posible. para bicicletas estilo para damas y no convencionales marcos no es posible mantenerlas a 'nivel' en una bicicleta de carretera con un tubo de nivel superior coloque el tubo en las cunas con el bloque antimovimiento en el poste del asiento.

¡Precaución! Este porta bicicleta se ha diseñado para la mayoría de los vehículos. Es la responsabilidad del usuario asegurar la instalación segura y apropiada de este producto. La instalación incorrecta de este producto puede dar lugar a daños a tus bicis, vehículo, o vehículos que siguen detrás de ti. Si los cojines de este portabici (o de cualquier otro) se están reclinando contra el cristal o un panel suave, estar enterado que esto puede causar daño a tu vehículo. El fabricante de este producto no extenderá la garantía a ninguna por daños no atribuidos a un defecto en materiales y la ejecución. La guía impresa en este manual se usa para referencia general solamente. Si se cambia el diseño del vehículo, materiales y los afinados usados en los vehículos automotores de marca la responsabilidad es del usuario de determinar el uso de este producto. No unir los ganchos al aluminio, cristal, fibra de vidrio, fibra de carbón. ¡Comprobar por favor la guía apta en la página trasera antes de la instalación! Si la marca y el modelo de tu coche se enumera como “ningún ajuste,” comprobar con tu distribuidor sobre ayuda de la instalación, el intercambio para saber si hay otro modelo que quepa, o el reembolso. Esta guía no es completo debido a los cambios continuos en diseño automotor. preguntas, llamar nuestro departamento de servicio de cliente al: 310-516-8600 lunes. viernes. de 7:00 AM-3: 00PM tiempo del pacífico.

CAUTION!

This bicycle carrier has been designed to attach securely to most vehicles. It is the user's responsibility to insure the safe and proper installation of this product. Improper attachment or installation of this product may result in damages to your bicycles, vehicle, or vehicles following behind you. If the pads of this rack (or any rack) are resting against glass or a structurally soft panel, be aware that this may cause damage to your vehicle. The manufacturer of this product will not extend the warranty to any damages not attributable to a defect in materials and workmanship. The fit guide printed in this manual is intended as a general reference only. On-going changes in vehicle design, materials and finishes used on motor vehicles make it the user's responsibility to determine the use of this product. Do not attach hooks to aluminum, glass, fiberglass, moldings, spoilers or carbon fiber parts. Please check the Fit Guide on the back page prior to installation!

If the make and model of your cars is listed as a “No Fit,” check with your dealer about installation assistance, exchange for another model that will fit, or refund. This guide is not complete due to continuous changes in automotive design. For answers to questions, call our customer service department at: 800-747-4085 Mon.-Fri. from 7:00AM–3:00PM Pacific time OR Email us anytime at info@hollywoodracks.com

Limited Lifetime Warranty (effective January 1, 2008):

Hollywood Racks will warranty its car racks and accessories during the time that an original retail purchaser owns the product subject to the exclusions and limitations of this warranty. Hollywood Racks will remedy defects in materials and workmanship by repairing or replacing (at its option) the complete rack or a defective part without charge for labor or parts. Hollywood Racks may elect (at its option) to issue a refund equal to the purchase price paid for the product.

This warranty does not cover problems caused by normal wear and tear including (but not limited to) weather, scratches, dents, rust, accidents, unlawful vehicle operation, misuse, abuse, neglect, theft, unauthorized modifications, or unauthorized repair. No warranty is given for defects resulting in incorrect assembly, incorrect installation onto the vehicle, installation on a “no fit” vehicle, incorrect attachment of bicycles onto the rack, or overloading of the rack's weight restrictions. This warranty terminates if the original retail purchaser transfers the product to any other person.

If a product is believed to be defective, the original retail purchaser should contact either the original retailer or Hollywood Racks directly at 800-747-4085 or at info@hollywoodracks.com

Disclaimer of Liability: Repair or replacement of a defective product or the issuance of a refund or credit (as determined by Hollywood Racks) is a purchaser's exclusive remedy under this warranty. Damage to a purchaser's vehicle, cargo, bicycles and or to any other person is excluded. This warranty is expressly made in lieu of any and all other express warranties, whether oral or written. Hollywood Racks shall not be liable for any direct, indirect, consequential, incidental, special, punitive or any other damages in connection with the purchase, use or handling of this product. Some states do not allow the exclusion or limitation of consequential or incidental damages and the above limitation may not apply to you. This warranty gives you specific legal rights and you have other rights, which vary from state to state.

Hollywood Racks
12812 South Spring Street Los Angeles, CA 90061
(800) 747-4085 (310) 516-8600 Fax (310) 516-8955
Customer Service Hours: 8:00 AM- 3:00 PM Pacific Time
www.hollywoodracks.com info@hollywoodracks.com