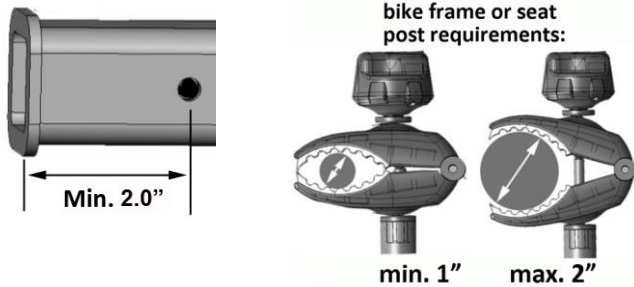


# Hollywood Racks RV Rider E-Bike Hitch Rack Assembly and Installation Guide

Model No. HR1600 (Up to 3" wide tires)  
Model HR1700 (Universal sized up to 5" wide tires)

For use on 2" (min. Class III) hitches only\*. Do not use a 1 1/4" - 2" hitch adapter. See below for other restrictions.



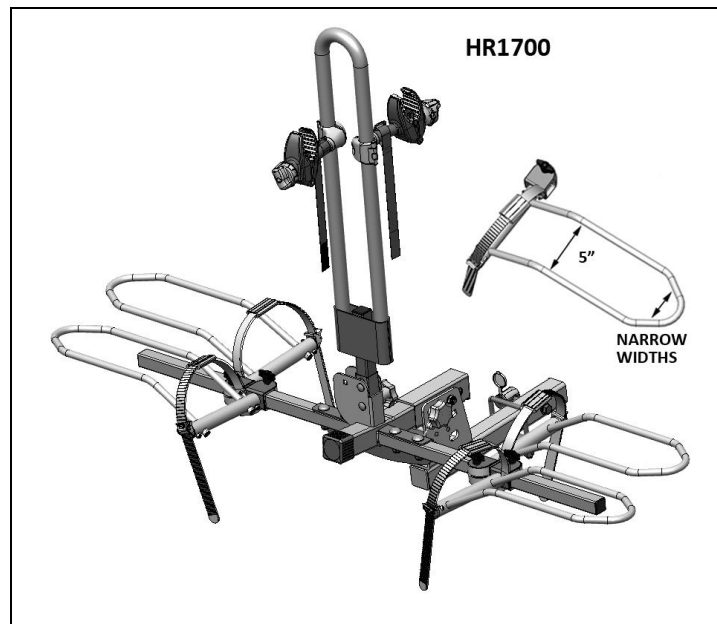
Maximum weight per bicycle is 80 lbs.  
Maximum bicycle wheelbase 60"

Not intended for use with motorized bicycles, mopeds, motorcycles or 3 wheel bikes (trikes).

For further video assembly & installation instructions, please visit [hollywoodracks.com](http://hollywoodracks.com)

## RESTRICTIONS – PLEASE READ BEFORE INSTALLATION

**RATED FOR USE WITH MOTOR HOMES (CLASS A, B, C), FLAT TOWING, AND 5<sup>TH</sup> WHEELS. IF FLAT TOWING, YOUR TOWED VEHICLE MUST HAVE A MINIMUM CLASS III RECEIVER HITCH. NOT TO BE USED WITH A 1 1/4"-2" HITCH ADAPTER OR WITH A BUMPER MOUNT HITCH ADAPTER.**



### 5<sup>TH</sup> WHEEL REQUIREMENTS:

1. TRAILER HITCH MUST HAVE A MIN. 350 LBS TONGUE WEIGHT CAPACITY (MIN. CLASS 3)
2. DOUBLE AXLE AND 24' IN LENGTH (BOX LENGTH)
3. MINIMUM GVW IS 5000 LBS

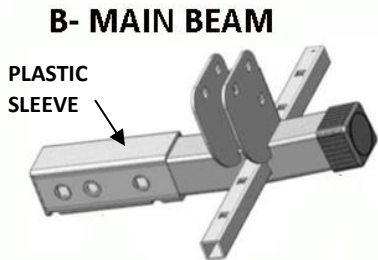
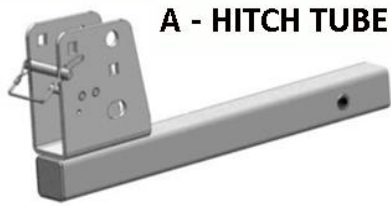
*Please see Page 12 (back page) before installation*

**NOT INTENDED FOR USE WITH TRAVEL TRAILERS**

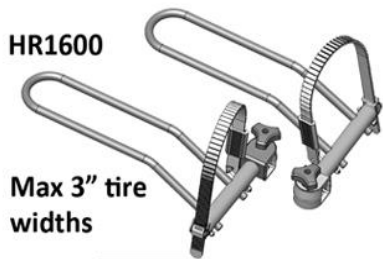


**WARNING!**  
DO NOT USE  
WITH BUMPER  
MOUNTED HITCH  
ADAPTERS!

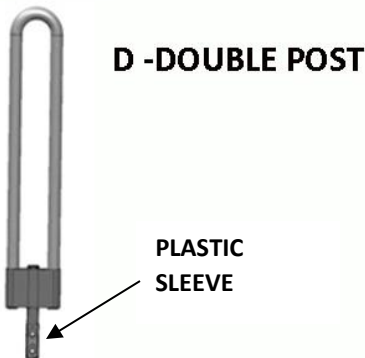
# PARTS LIST



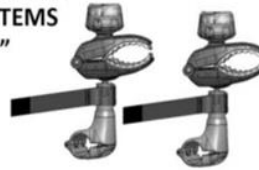
**C - WHEEL HOLDERS**  
(TWO PAIR LEFT & RIGHT SIDE)



**OR**



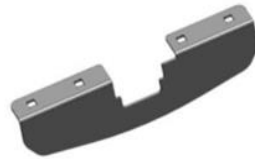
**E - BIKE FRAME CLAMPS**  
LOCKING, KEYED  
ALIKE TO ITEMS  
"I" AND "J"



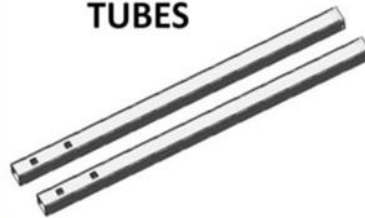
**E1- Set of longer bolts & tubes for frame clamps**



**F - SUPPORT BRACKET**



**G - WHEEL SUPPORT TUBES**



**I - THREADED LOCKING HITCH PIN**



**J - 7' SECURITY CABLE**



**K - WHEEL SUPPORT TUBE HARDWARE**

4 EACH  
10mm carriage bolts, nuts, and spacers

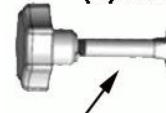


**L - MAIN BEAM HARDWARE**

2 each: 1/2-20 bolts, nuts, washers,  
1 each: spacer



**M - Knob for main beam**  
(1/2-13 thread size)



**M1 - Bolt for main beam**

**N - DOUBLE POST HARDWARE**

1 EACH  
10mm carriage bolt, nut, washer



**O - DOUBLE POST KNOB AND BOLT**  
10mm



**P- WRENCH, 17mm and 19mm**



**Q - SOCKET WRENCH**  
17MM



**R - Wheel tube stop screws**



**S - SAFETY STRAPS QTY 3**



**Section 1: Assembly - requires adjustable wrench or 3/4" wrench, Phillips screwdriver, included tools "P" and Q"**

**Step 1: Assemble main beam to hitch tube**

Install hitch tube (A) into your vehicle's 2" receiver per Fig. 1.

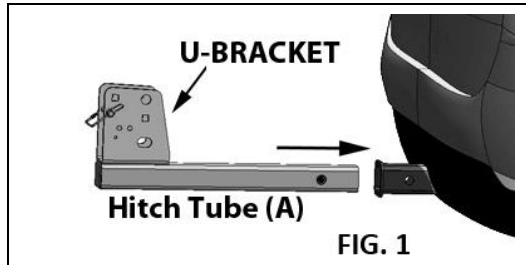


FIG. 1

Install 1/2-13 threaded hitch pin (I) through the hitch tube and receiver. Tighten using the provided wrench (P) or 3/4" socket wrench.

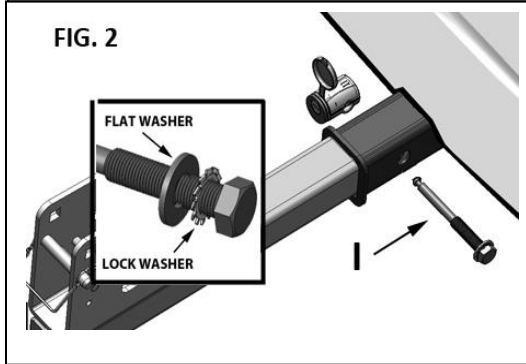


FIG. 2

Fig. 3: Push the plastic sleeve all the way forward on the main beam so that the three holes are exposed.

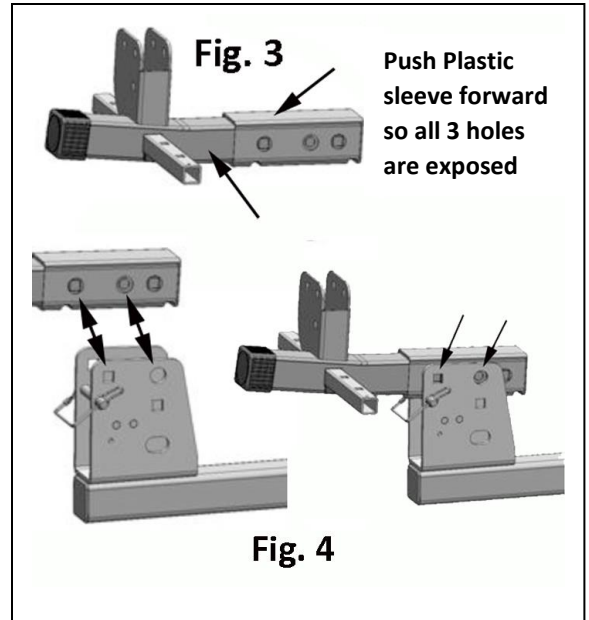


Fig. 4

Fig. 4: Position main beam (B) inside the hitch tube's large U-bracket and align the holes.

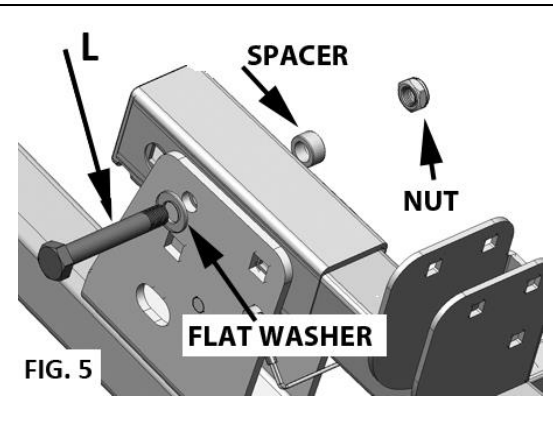


FIG. 5

Fig. 5 & 5A: Slide the flat washer onto pivot bolt (L), then insert the pivot bolt so it passes through both the main beam and U-shaped bracket.

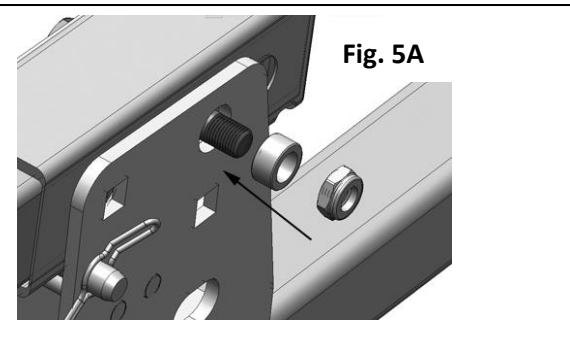


Fig. 6: Insert carriage bolt (M) through the square hole in the U-bracket and pass it through the main beam until it protrudes on the other side of the U bracket.

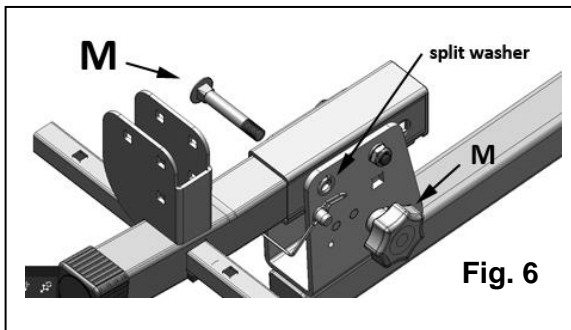


Fig. 6

Fig. 7: Slide the split washer onto the bolt.

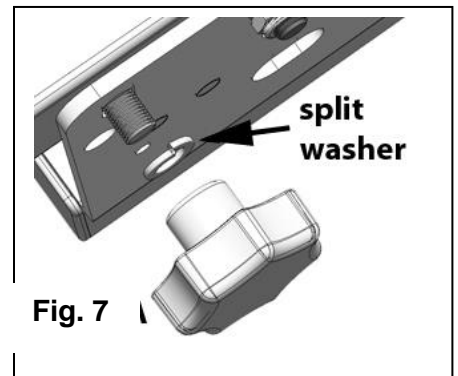
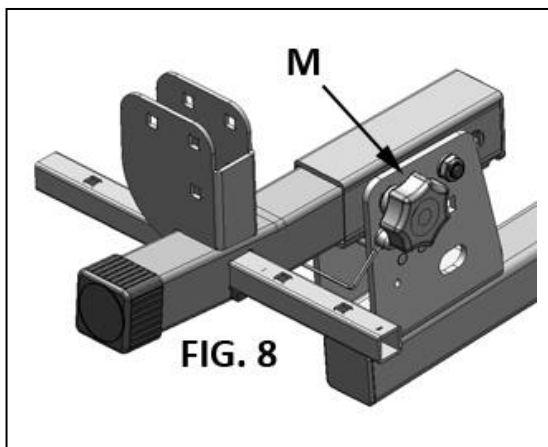


Fig. 8: Install the knob for bolt (M). Tighten securely.



## Step 2: Assemble double post, wheel tubes and support bracket to main beam

Fig. 9: Check that plastic sleeve is installed on double post. Position double post (D) in the bracket of the main beam.

Fig. 10: Insert carriage bolt (N) in the upper hole, then install flat washer and nut onto the bolt. Use wrench to tighten the nut.

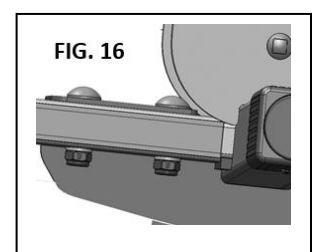
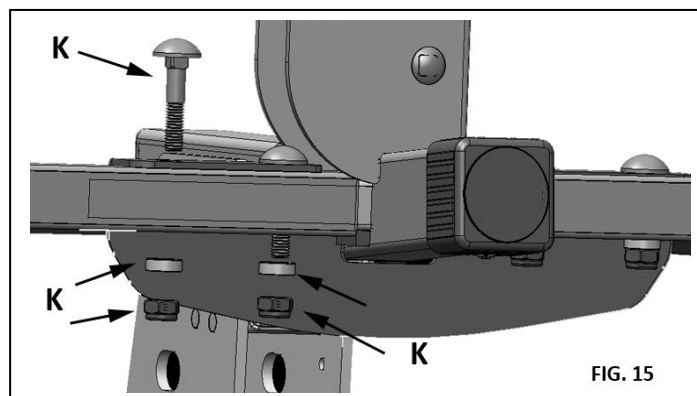
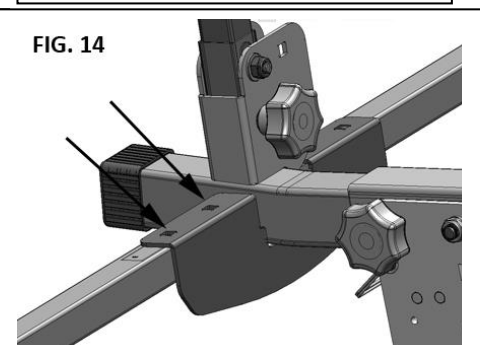
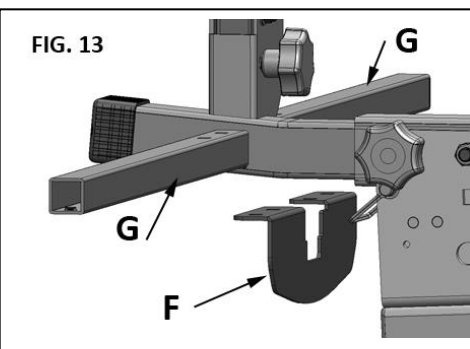
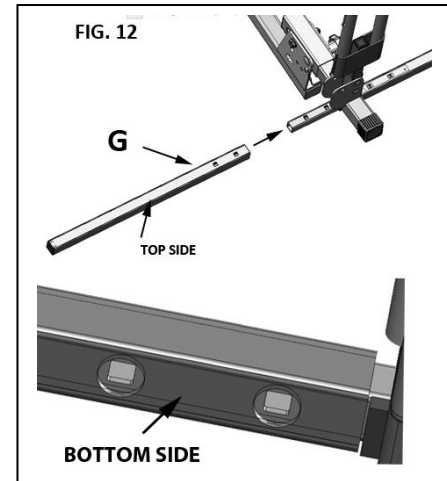
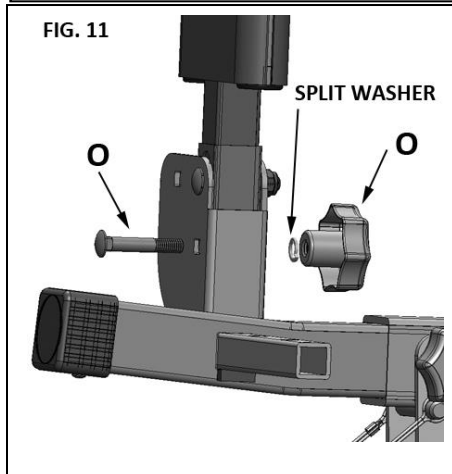
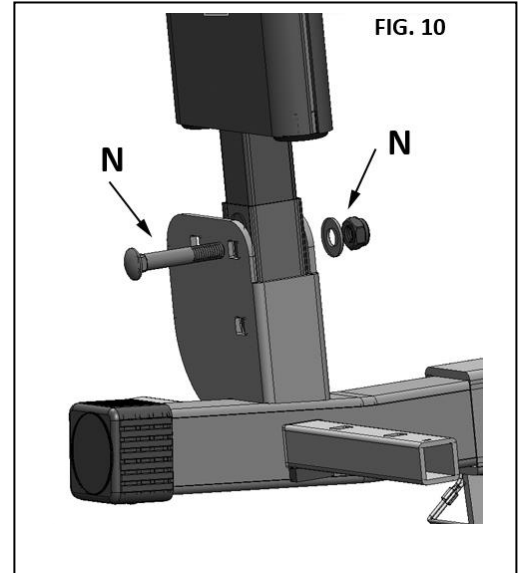
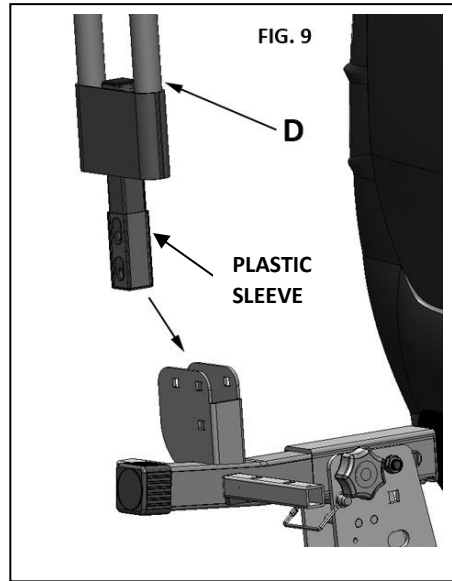
Fig. 11: Insert carriage bolt (O) through the lower hole, then install split washer and knob onto the bolt. Tighten knob securely.

Fig. 12: Slide wheel tubes (G) onto posts of main beam. Square holes of wheel tubes (G) are on top, large round holes on the bottom side.

Fig. 13: Position support bracket (F) onto wheel tubes. Align the square holes per Fig. 14

Fig. 15: Insert carriage bolts (K) from the top through the support brace and wheel tubes. Ends of bolts should now be protruding on the lower side of the wheel tubes. Slide the spacers up and onto the end of the bolt. Install and “finger tighten” the nuts.

Fig. 16: Use socket wrench (Q) to tighten the “K” nuts securely.



### Step 3: Install Wheel Holders

Fig. 17: Loosen the knobs on the wheel holders and slide them onto the wheel tubes per Fig. 17. They are snug, you may need to tap them on. Install the wheel holder for inside bike passenger side first (1), next the outside bike passenger side (2), then the outside bike's driver side (3), and finally the inside driver side wheel holder (4).



### Step 5: Install Frame Clamps (Item E)

Fig. 18: Identify the frame clamps, they are both the same.

Fig. 19: Unscrew the knob and remove the long carriage bolt. Careful not to misplace the washer/spacer that goes between the clamp and the knob.

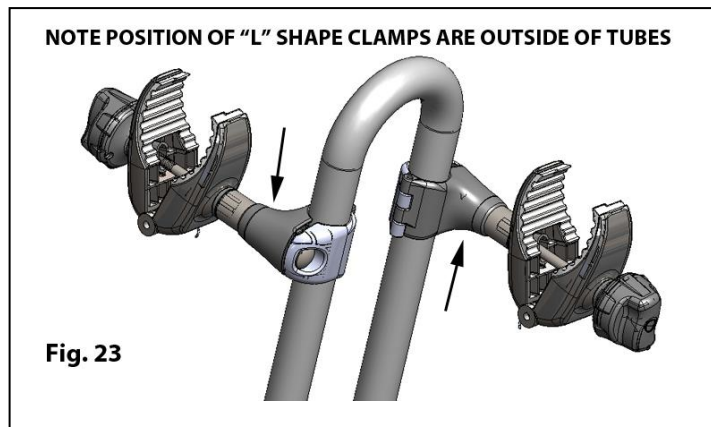
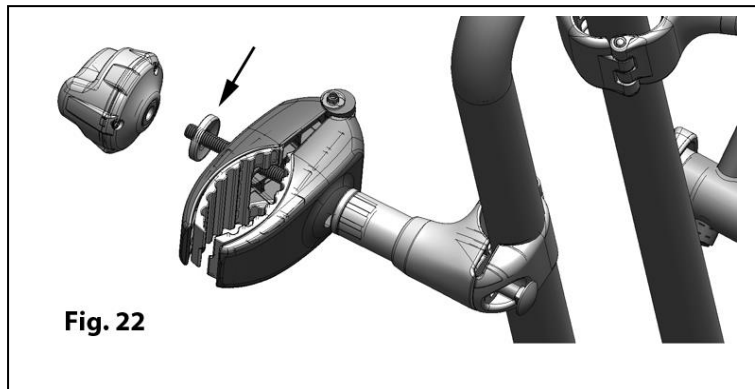
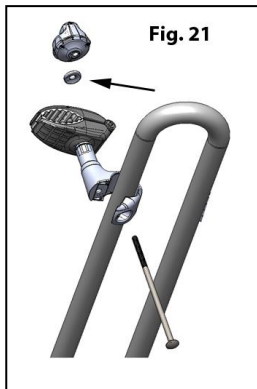
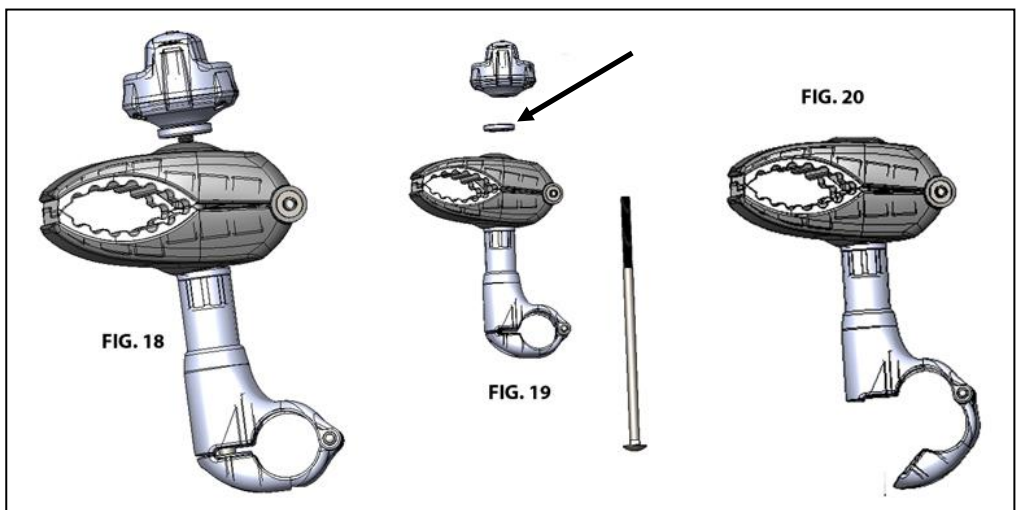
Fig. 20: Rotate the lower portion open.

Fig. 21 and 22: Re-install the frame clamp as shown.

Fig. 23: Note position of the "L" shaped clamp on the tube is outside of the double post.

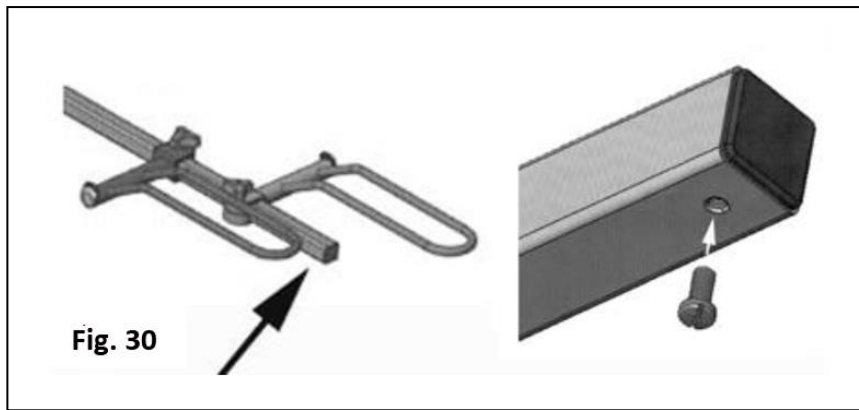
### USING THE LONGER CARRIAGE BOLTS AND TUBES (ITEM E1):

Per Fig. 24: Depending on your bicycles, you may need to use the included longer carriage bolts and tubes for your rack. Follow the same instructions as outlined above in Fig. 18-23.



**Step 6: Installing the wheel tube stop screws:**

*After determining the final position of the wheel holders,* install the two stop screws (item R) into the bottom of the wheel tubes per Fig. 30. Use Phillips screwdriver. (Note: This step should be done after you have installed your bikes and do not need to remove the wheel holders).



**Folding the double post down**

Fig. 25a: Loosen knob and remove bolt (O). Be careful not to misplace split washer.

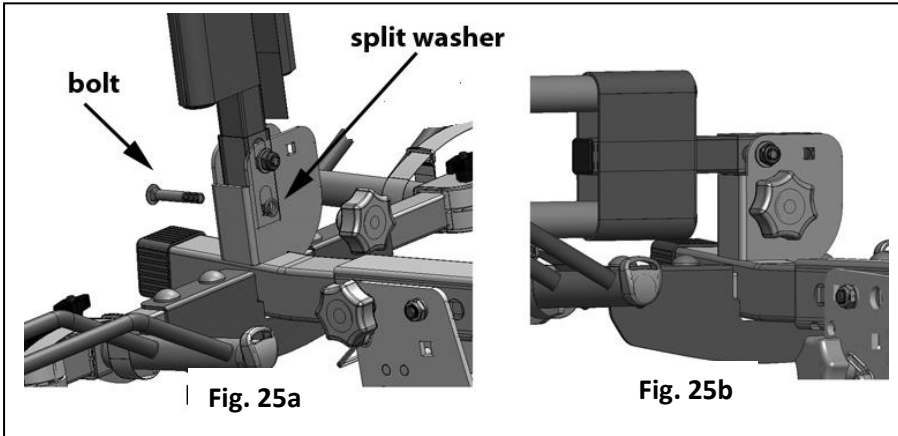


Fig. 25b: Rotate double post 90 degrees, then re-install carriage bolt, split washer and knob.

**Folding the rack flat against back of vehicle (note double post must be folded down)**

Fig. 26 and 27: Unscrew the knob for bolt (M). Rotate main beam 90 degrees up. Be careful not to misplace the split washer. Reinsert the bolt in hole indicated, slide the split washer onto bolt and install knob. Tighten securely.

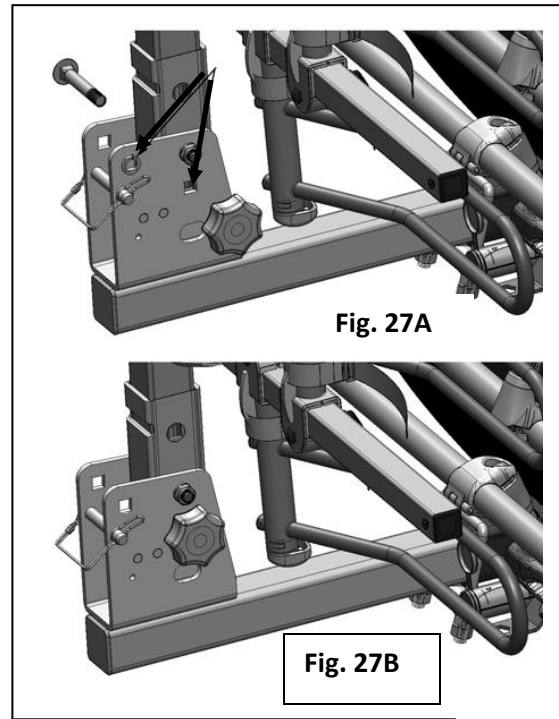
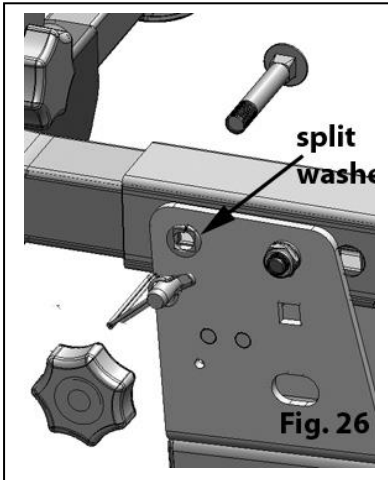
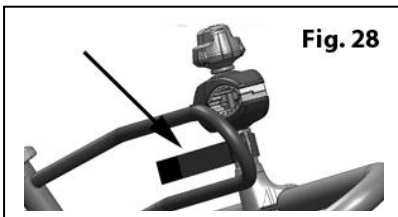


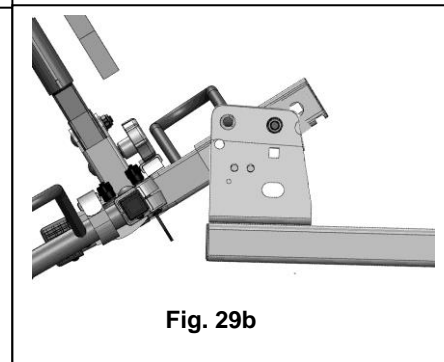
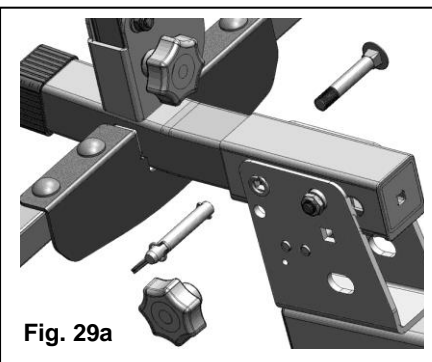
Fig. 28: Use the attached Velcro strap to attach the frame clamp to the wheel holder when the rack is folded against the vehicle.



**Tilting the rack**

Fig. 29a: Remove pin with clip, knob and carriage bolt

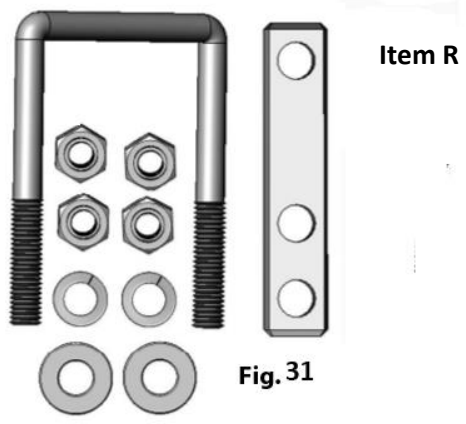
Fig. 29b: Gently tilt rack down.



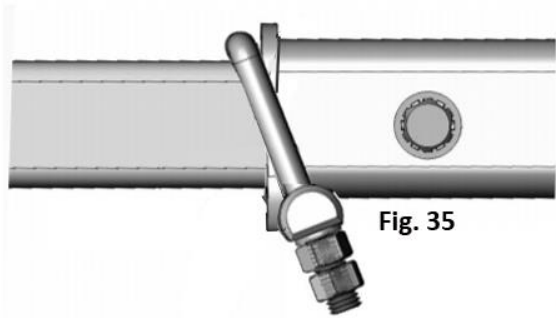
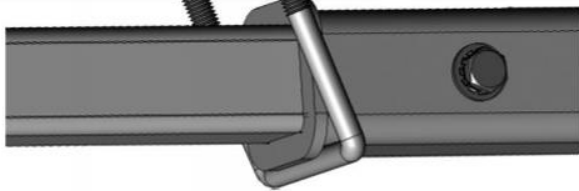
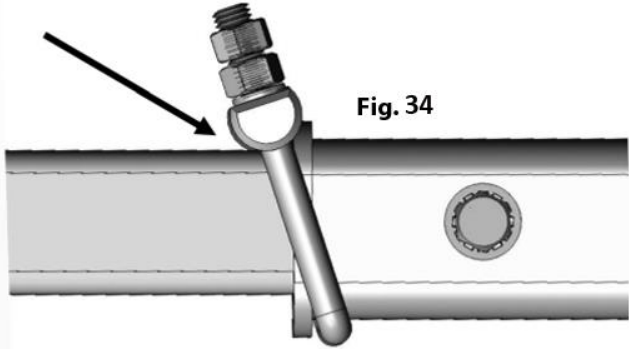
# Install hitch tightener (note: hitch tightener is used to reduce the rack's vertical wobble)

**Tools Required:** Adjustable wrench or 7/8" wrench  
**Contents:**  
 U-Bolt for 2" hitches (qty = one)  
 Clamp Bar (qty = one)  
 Split Washers (qty = two)  
 Flat Washers (qty = two)  
 1/2-13 Hex Nuts (qty = four)

**Note:** This product requires a flange on your hitch



1. Check the package contents per Fig. 31
2. Per Fig 32 please note that this product requires that your hitch has a flange.

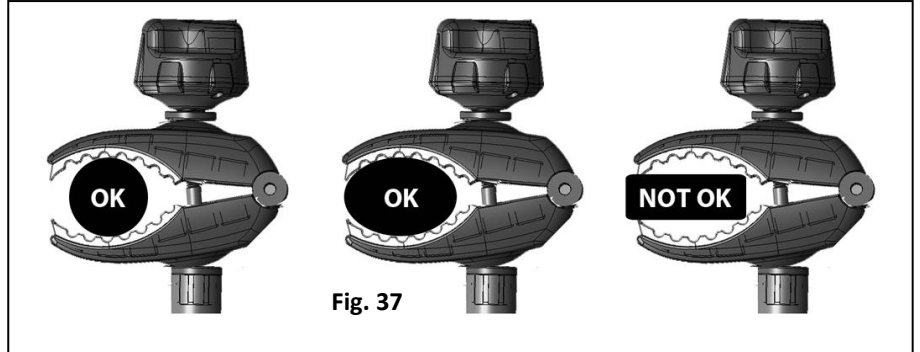
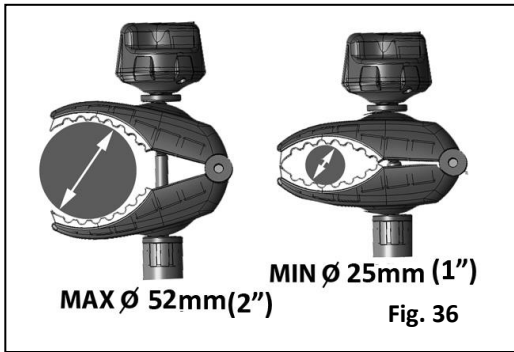


3. Place the U-bolt below the receiver hitch and behind the flange per Fig.
4. Slide the clamp bar onto the legs of the U-bolt. Rounded surface of the clamp bar must in contact with the flange and accessory tube per Fig.
5. Install the flat washers and thread a nut onto both legs of the U-bolt. Tighten the nuts securely so there is equal pressure on the clamp bar.
6. Install the split washers and thread the second set of nuts onto the legs of the U-bolt. Tighten securely, max. torque 25 ft-lbs.

*Note: The hitch tightener can be installed with the clamp bar below the hitch and in front of the flange per Fig. 35*



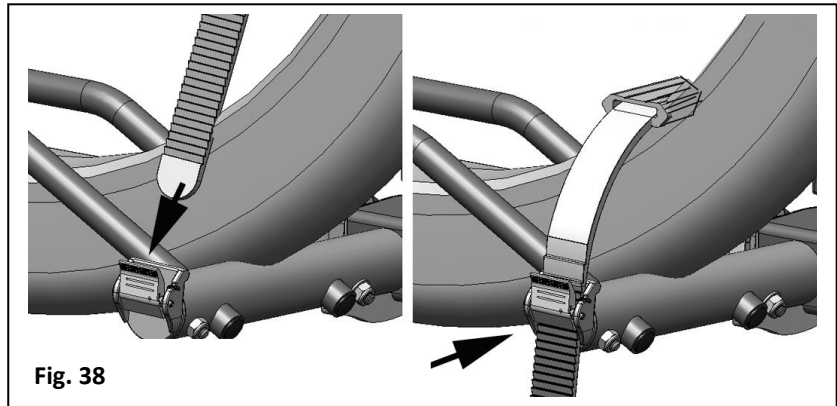
**Frame Clamp compatibility:** Check your bike frame or seat post to be sure the frame clamps will fit. If your bike frame is CARBON FIBER, be sure to clamp to the seat post. Minimum diameter is 25mm/1", Maximum diameter is 52mm/2". Please refer to Fig. 37 for frame shapes.



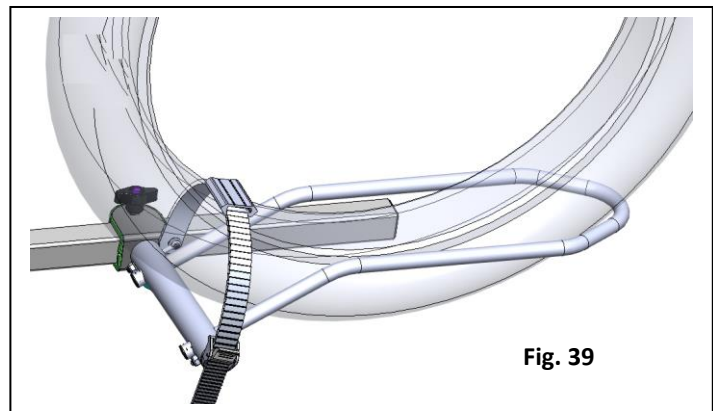
## Section 2: Bike attachment

### Fig. 38: Ratchet Strap Wheel

**Holders:** After the bike's wheels have been placed into the wheel holders, rotate the strap and lay it on top of the bike's wheel (ratchet teeth "up"). Insert the strap into the buckle and pull tight. Do not overtighten. Repeat for the second wheel. To release the strap, push in the spring loaded tab and pull the strap out of the buckle. Note: Straps should be inserted into the buckle when the rack is not in use.

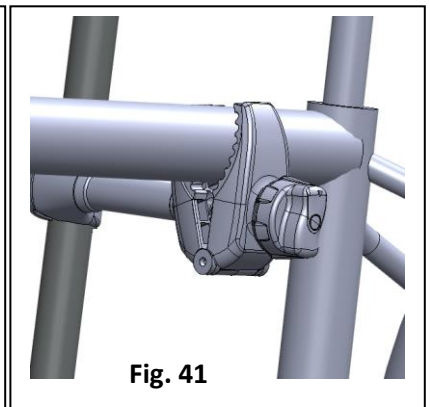
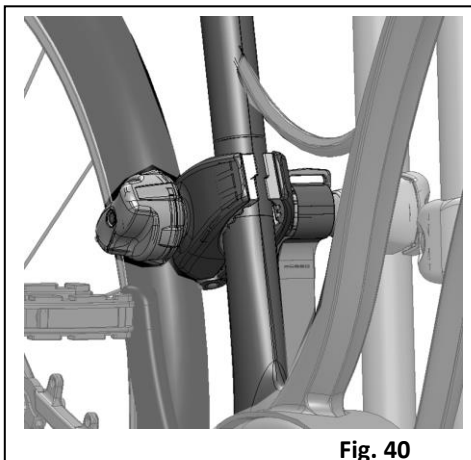


**Fig. 39: Model HR1700 with "universal sized" wheel Holders.** These wheel holders will fit bicycle tire sizes from 1 3/8" width road bike tires to 5" width fat tires.



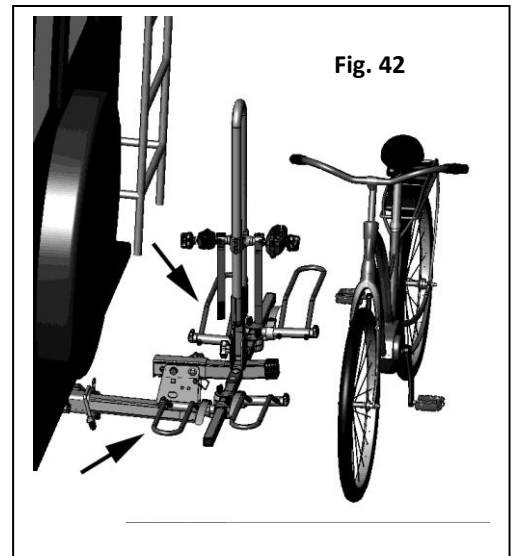
### Fig. 40, 41: Attach the frame clamp.

Unscrew (but do not remove) the knob to open the jaws of the clamp. Place around the frame or seat post, then tighten knob securely. Frame clamps are lockable, and keyed to the hitch pin and security cable. Always lock the clamp after bike installation. Repeat for the second or outer bike. **Use the included Tie-down strap between bikes and double post to reduce any extra bike motion. See Fig. 54 and 55**

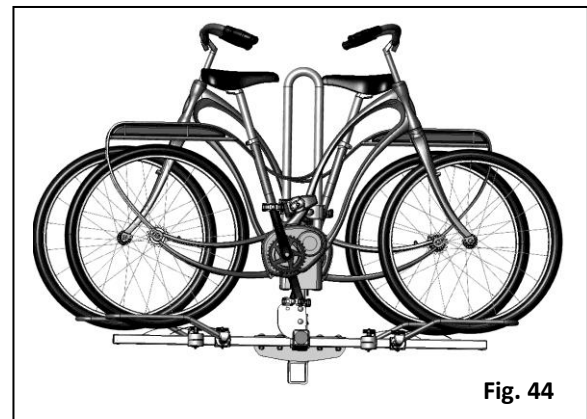
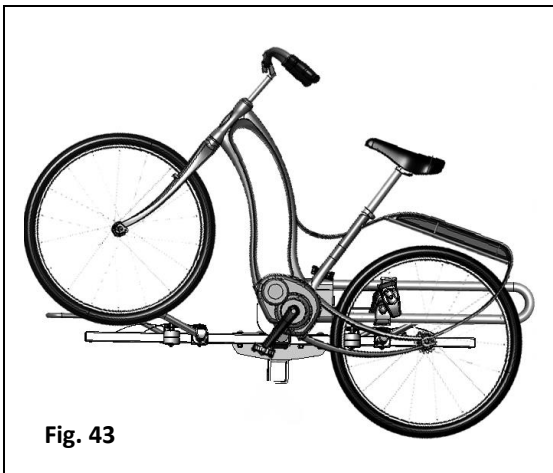




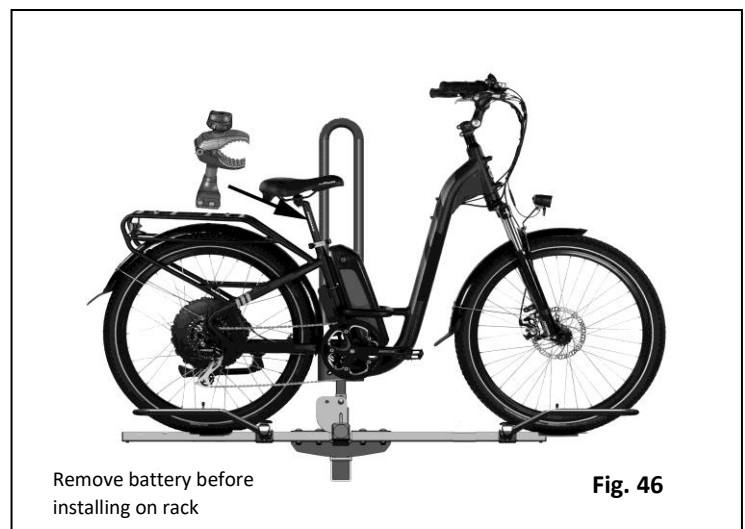
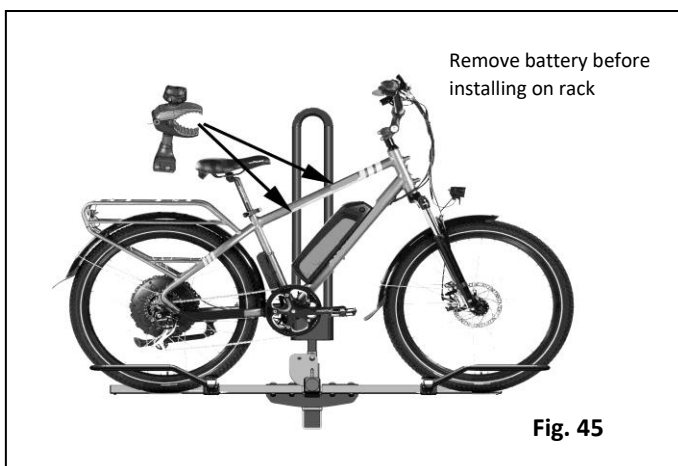
**Installing your bikes onto the RV Rider:** Please check Figs. 45-50 prior to bike installation for tips on how your particular frame style will fit best. Per your E bike's instructions and recommendations, remove battery. **Whenever possible, try to keep the bike centered on the rack due to uneven weight distributions on some non-mid drive E bikes.** Depending on your bike's size and design, it may be necessary to lower or raise the seat post due to possible handlebar to seat interference. *Bike frame fit tips:* Check Figs. 36 and 37 to be sure your bike frame and/or seat post will fit in the frame clamp. If it does not properly fit, you can use a bike adapter (Hollywood model BA-PRO) per fig. 51 and 52.



1. Position the first or inside bike in front of the rack, so that the bike frame or seat post can be securely attached by the clamp. Adjust the position of the wheel holders so they align with the bike's wheels. Repeat for the second or outside bike.
2. Fold down the double post.
3. Raise the front wheel of the first bike and place it on the outside wheel holder (Fig. 43), then raise the rear wheel and place it on the rack. You can then "walk" the bike into the inside wheel holders.
4. Raise and secure the double post. Make any final wheel holder adjustments and tighten knobs securely. Secure the frame clamp and wheel ratchet straps.
5. Repeat for the second or outside bike, handlebars on the opposite side of the first or inside bike (Fig. 44).
6. Attach safety strap per Fig. 54.



**Tip:** The frame clamp can be installed at the seat post for most step thru bikes (Fig 44), but a bike adapter can also be used depending on the bike's frame geometry and tube shape (Fig. 53 and 54).



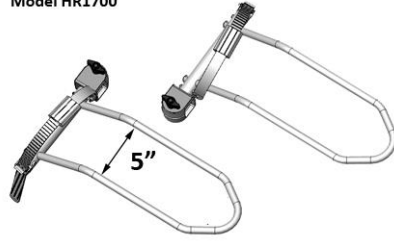
Remove battery before installing on rack

Fig. 47



Standard wheel holders handle up to 3" wide tires. If you have fat tires, such as the bike shown in Fig. 47, you will need Model HR1700 which can accommodate tire widths up to 5" wide.

Model HR1700



Remove battery before installing on rack

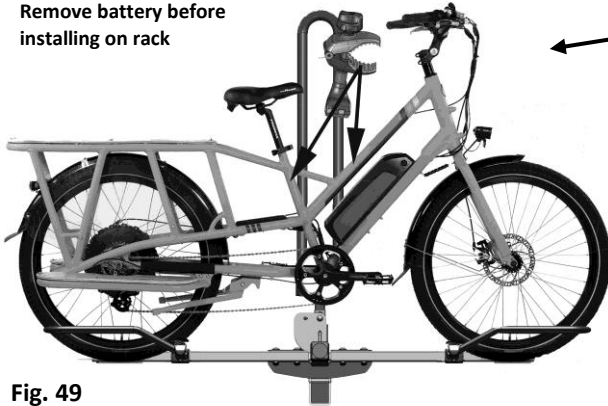


Fig. 49

If you are carrying **cargo bikes** (Fig. 49), please contact us to purchase the wider cargo bike wheel holders.

If you have a **carbon fiber bike**, only attach the clamp to a round steel or aluminum seat post. Do not attach the frame clamps to the frame or any other shaped seat post but round.

Remove battery before installing on rack

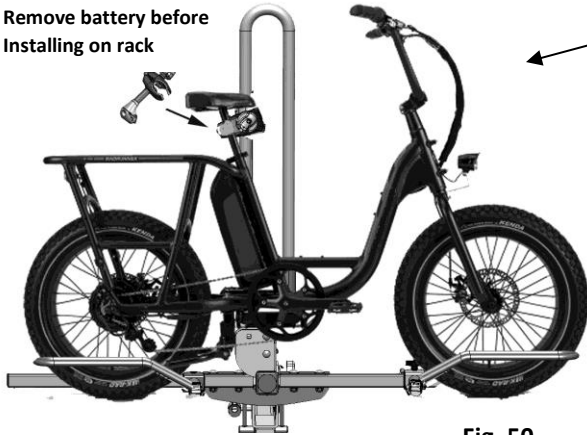


Fig. 50

If you have a 20" wheel dia. E bike equipped with a derailleurs, you will need to adjust your gear shifter into first gear (largest rear wheel chain ring). Alternatively, you can purchase the small wheel adapter (Fig. 51) which will raise the rear wheel up in the wheel holder. Please contact Hollywood Racks (model SWA-FT) for more information.



Fig. 51

Fig. 52



Some step-thru bikes may Require a top tube "bike Adapter". Please use Hollywood Racks Model **BA-Pro** (shown below).

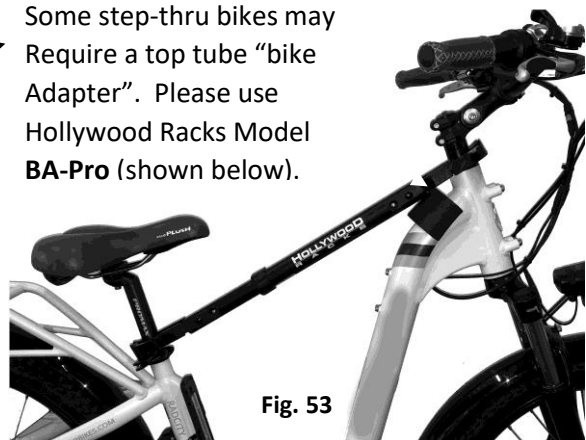
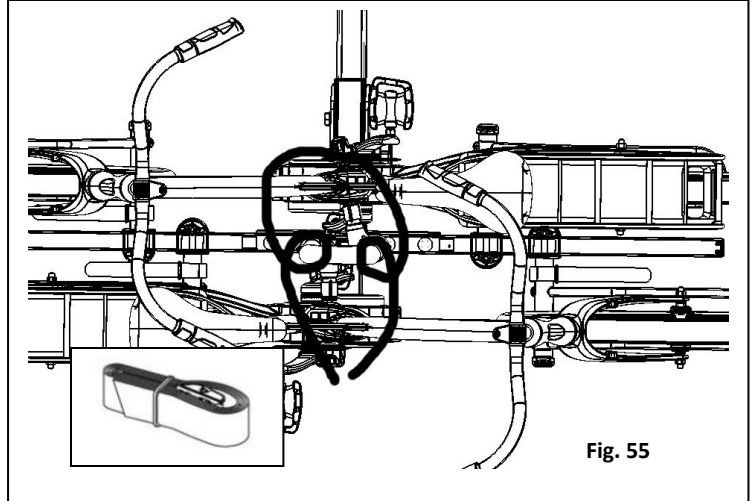
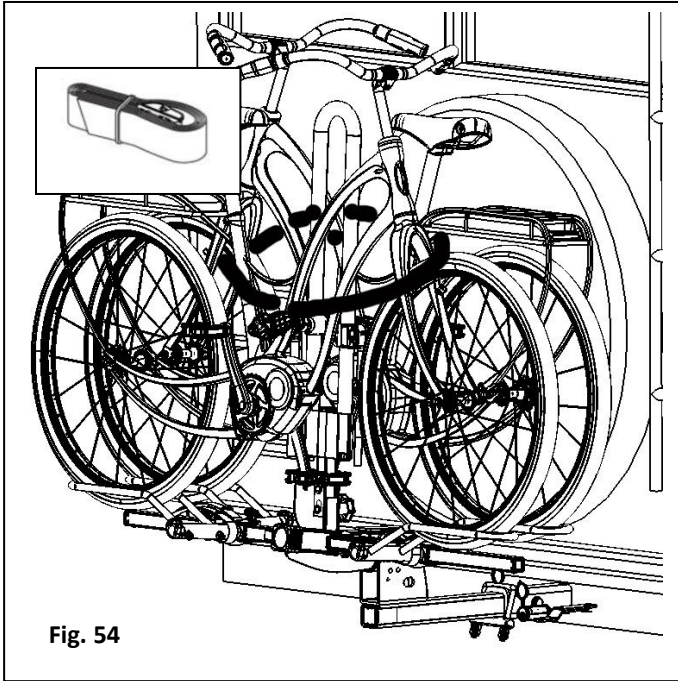


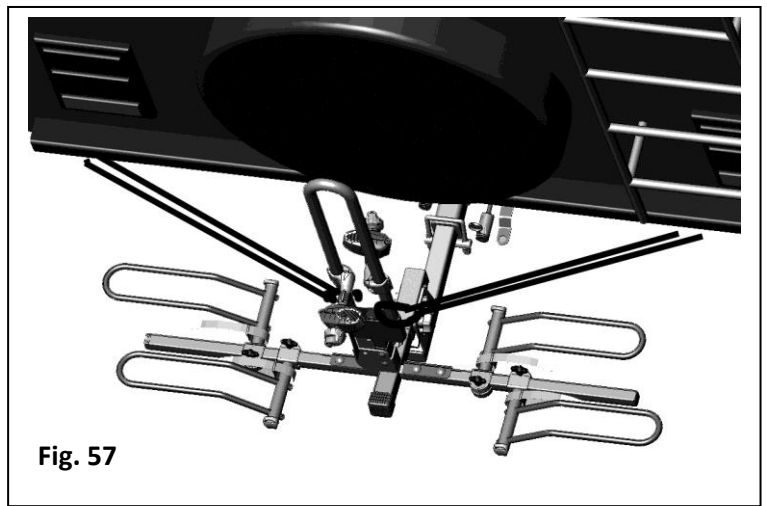
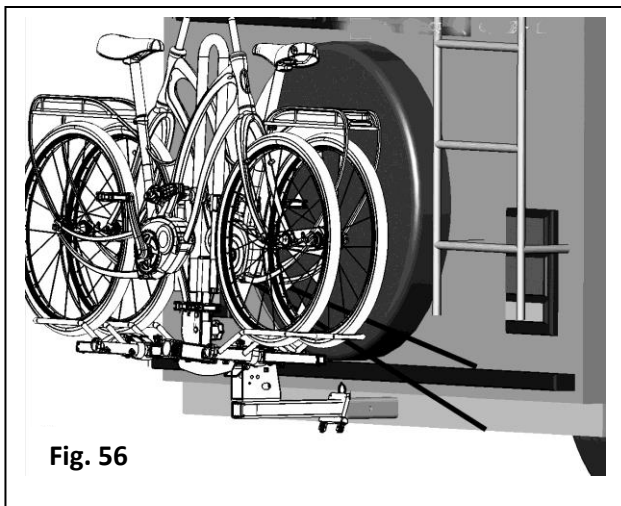
Fig. 53

Using safety straps to tie bikes to the double post and rack to vehicle (Fig. 54 through 57).



There are three safety straps (one short, two long) included with the rack. Use the short strap to secure the bikes (Fig. 54 & 55). Thread strap end through outer bike frame and around one of the double post's tubes, then through inner bike and double post. Feed the end of the strap into the buckle, and tighten securely.

Use the additional (long) safety straps to tie the rack back to the vehicle (Fig. 56 & 57). After the bikes have been secured, attach the long straps to the lower part of the double post, then outboard to attachment points on your vehicle's frame or bumper. Be aware that attaching to a ladder can damage the ladder's ability to properly be fastened to your motorhome.



Section 10: Use the included security cable for additional anti-theft protection. Thread the security cable through the bike frames, wheels and double post. Note: the security cable uses the same key as the locking knobs and hitch pin.



Fig. 58

**Double check before driving:**

Knobs are tight on wheel holders and clamps

Velcro straps are securely fastened

Hitch pin is tight and secure

Hitch tightener has been installed and is tight

Drive slowly on bumpy or dirt roads –

Follow bicycle weight limits per page 1



OK

OK



OK



**5th wheels must be double axle, min. 5000 lbs GVW  
5th wheel must have class 3 or higher hitch, min. tongue weight 350lbs**

**Limited Lifetime Warranty (effective January 1, 2008):**

Hollywood Racks will warrant its car racks and accessories during the time that an original retail purchaser owns the product subject to the exclusions and limitations of this warranty. Hollywood Racks will remedy defects in materials and workmanship by repairing or replacing (at its option) a defective part without charge for labor or parts. Hollywood Racks may elect (at its option) to issue a refund equal to the purchase price paid for the product. This warranty does not cover problems caused by normal wear and tear including (but not limited to) weather, scratches, dents, rust, accidents, unlawful vehicle operation, misuse, abuse, neglect, theft, unauthorized modifications, or unauthorized repair. No warranty is given for defects resulting in incorrect assembly, incorrect installation onto the vehicle, installation on a "no fit" vehicle, incorrect attachment of bicycles onto the rack, or overloading of the rack's weight restrictions. This warranty terminates if the original retail purchaser transfers the product to any other person. If a product is believed to be defective, the original retail purchaser should contact either the original retailer or Hollywood Racks directly at 800-747-4085 or at [info@hollywoodracks.com](mailto:info@hollywoodracks.com) **Disclaimer of Liability:** Repair or replacement of a defective product or the issuance of a refund or credit (as determined by Hollywood Racks) is a purchaser's exclusive remedy under this warranty. Damage to a purchaser's vehicle, cargo, bicycles and or to any other person is excluded. This warranty is expressly made in lieu of any and all other express warranties, whether oral or written. Hollywood Racks shall not be liable for any direct, indirect, consequential, incidental, special, punitive or any other damages in connection with the purchase, use or handling of this product. Some states do not allow the exclusion or limitation of consequential or incidental damages and the above limitation may not apply to you. This warranty gives you specific legal rights and you have other rights, which vary from state to state.

**Hollywood Racks**

12812 South Spring Street Los Angeles, CA 90061 (800) 747-4085 (310) 516-8600 Fax (310) 516-8955  
Customer Service Hours: 8:00 AM- 3:00 PM PST [www.hollywoodracks.com](http://www.hollywoodracks.com) [info@hollywoodracks.com](mailto:info@hollywoodracks.com)

Made in Taiwan

RV Rider Models HR1600 and HR1700 V3.6.2 06-2020