

Assembly and Installation Instructions

Warning! This product **NOT** to be used on any trailer or trailered vehicle.

- Drive slowly when using the rack on bumpy or dirt roads.
- Check the rack bikes and straps regularly during use.
- If you have any questions or installation problems, please see your Hollywood Racks retailer or contact Hollywood Engineering at 800-747-4085.
- Weight Capacity for the Traveler HR9200 Rack: 35 lb. per bike. Not to be used for Electric Bikes.

After opening the Traveler box, you should have the following:

- Upright beam (Fig 1.1)
- Receiver Tube (Fig 1.2)
- Two support arms (Fig. 1.3)
- Parts bag including two knobs and hardware (Fig. 3)
- Bag with 15 rubber straps
- Tie down strap (attached to upright beam)
- Parts bag including (Fig. 2):

| Item # | Qty | Description |
|--------|-----|--------------------|
| A | 1 | 1/2" diameter bolt |
| B | 2 | large flat washers |
| C | 1 | 1/2-20 nut |
| D | 1 | lynch pin clip |
| E | 1 | threaded hitch pin |

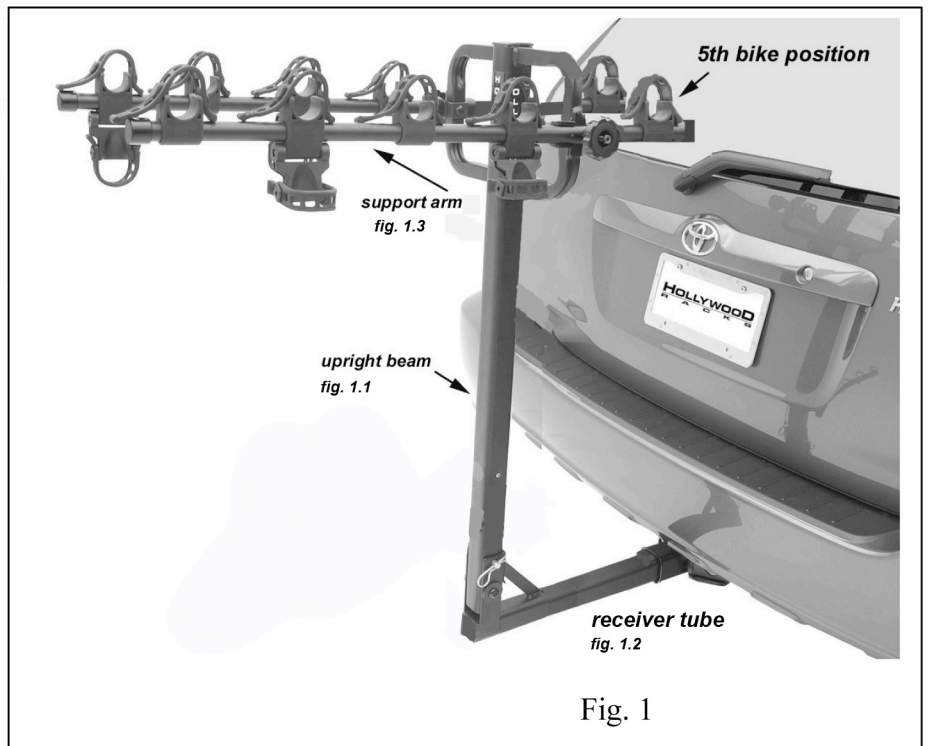

Fig. 1

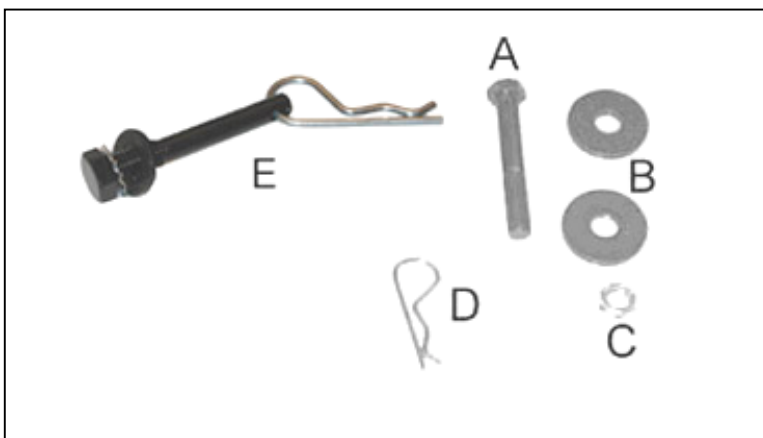

Fig. 2

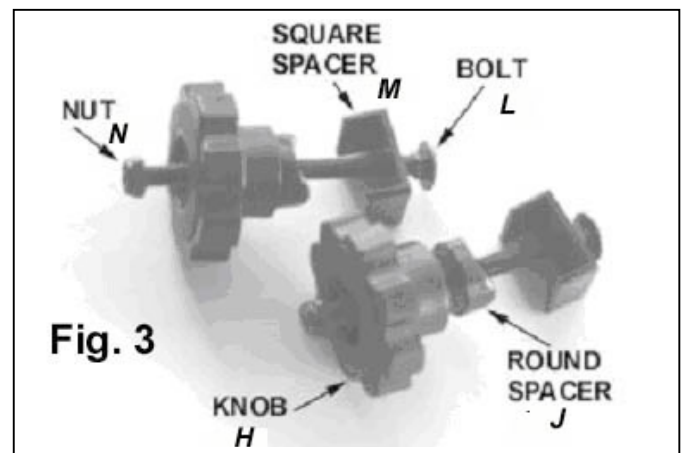

Fig. 3

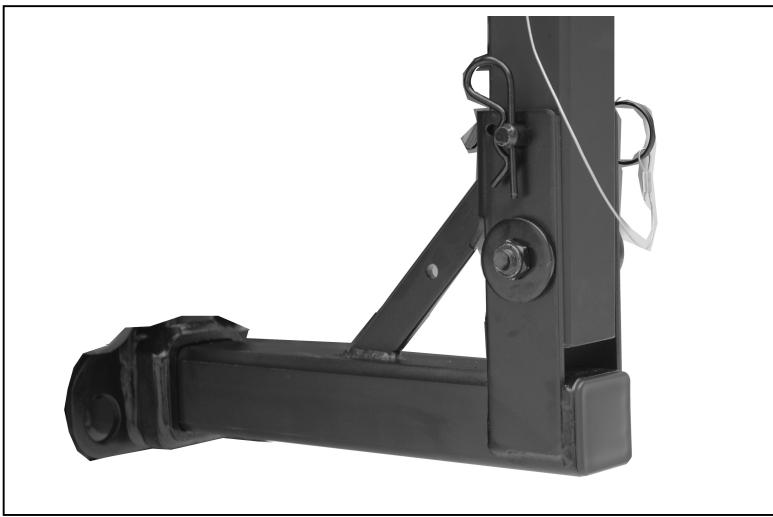

Fig. 4: Receiver Tube

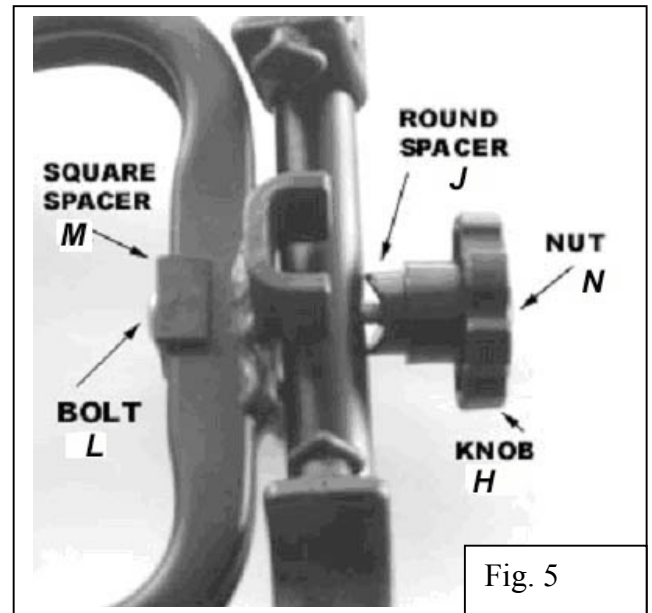

Fig. 5

Assembly:

Tools required: 2 adjustable wrenches or two $\frac{3}{4}$ " wrenches (open, box or socket).

1. The rack is easily assembled on your workbench or any flat surface. To assemble the rack, lay the upright beam face down on the bench (Hollywood sticker facing down). Place the receiver tube's bracket onto the end of the upright beam so that the receiver tube is pointing up.
2. Place a washer **B** on the end of bolt **A**, then insert the bolt through the lower hole of this bracket, and pass it through the lower hole of the upright beam. Once the bolt is protruding through the other side of the bracket, install the other washer and nut **C**. Tighten the nut securely using your adjustable wrenches or $\frac{3}{4}$ " wrenches. Insert the lynch pin through the upper hole, then install the lynch pin clip **D**. Refer to Fig. 4
3. To install the support arms: Locate parts bag with knob assembly (includes knob, carriage bolt, square spacer, round spacer and nut). Insert the bolt **L** through the square spacer **M**, then through the bike rack frame and support arm. Then install the round spacer **J** and knob **H**. Tighten knob, then install the nut **N** on the very end of the bolt so that the nut's nylon lock catches the bolt end. Repeat for other side. See Fig. 5
Note: nut requires $\frac{1}{2}$ " or 13mm socket wrench for tightening.



FIG. 6 Driver's Side Support Arm



FIG. 7 Passenger's Side Support Arm

To position the arms for use, loosen knob **H** on the rack's support arms, pull out the support arms and rotate them into the horizontal position. The arms should fit into the welded steel channels. Retighten the knobs securely. Rotate lower brace to its horizontal position.

Installing the Traveler rack on your vehicle:

4. Within the parts bag, locate the hitch pin, flat and star washers and clip (Fig. 3E).
5. Inserting the rack into the trailer hitch: try to get the receiver tube as parallel to the trailer hitch as possible, then slide the rack in a couple of inches until the hole on receiver tube the rack lines up with the hole in your hitch.
6. Slide the flat washer then the star washer over the threaded hitch pin, then Insert the hitch pin through the trailer hitch (receiver) and receiver tube. Thread the hitch pin into insert tube using a $\frac{3}{4}$ " wrench (box, open end or socket type) or an adjustable wrench. Tighten securely. Install the hitch pin clip through the hole at the end of the hitch pin. **To lock the rack to your vehicle, you can alternately place a padlock through the hole at the end of the threaded hitch pin. If you use a padlock, the hitch pin clip will not be used.**

Installing your bikes on the Traveler rack:

7. If the support arms are not already in a horizontal position, back off the knob at the end of the rack's support arms, pull out the support arms and rotate them into the horizontal position. Retighten the knobs securely.
8. For ease of installation, we suggest you put the bigger bikes on the inside (closest to vehicle), smaller frames or kids bikes on the outside. The first bike loaded should have the handlebars facing towards the driver's side of the vehicle. Place the top tube (or closest appropriate frame tube) onto the bike cradles, install the straps over the bike tube and attach to the anchor tabs on both sides of the cradle. Use a strap notch-hole that provides a snug fit, but take care not to pull the strap over-tight. This can put undue stress on the bike's paint, and may over-stretch the strap, making it more susceptible to breakage. Be sure to use the Anti-Sway blocks (below the support arms) to strap the bikes seat tube (or other frame tube as appropriate) to prevent the bikes from swaying on the **Traveler** rack. Note Fig. 8a & 8b below for correct application of the straps on the anti-sway blocks.

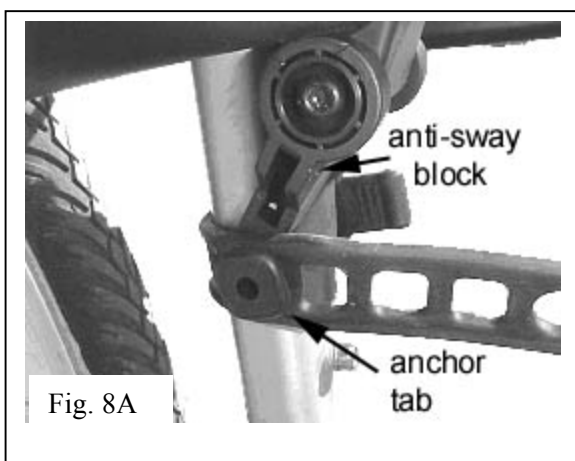

Place the second bike's handlebars on the passenger side, and so on. If carrying five bikes, use the bike holder position located between the upright beam and the vehicle (fig. 1.4) This position does not have an anti-sway cradle, but you can brace the bike's crank arm against the upright beam. After all the bikes have been installed, use the safety tie down strap (attached to the rack) and wrap it through the frames all of the bikes. Attach to the buckle then tighten securely.

REMOVING THE BIKES AND RACK

9. To remove the bikes, simply undo the straps and gently lift the bikes off. If you're in a parking lot, be sure to fold down the support arms and fold up the wheel brace so as to minimize the length of the rack when not in use. To remove the rack from the vehicle, fold the support arms, and remove the threaded hitch pin. Then slide the rack out of the hitch receiver.

BACKING OUT OF DRIVEWAYS AND GOING OVER BUMPS

10. Please keep in mind that when transporting bikes, you will be carrying more weight on your hitch. This means the rear of your vehicle will be lower to the ground. When going up driveways or over bumps, drive slowly and at an angle if possible. If you have a car or minivan where the hitch is low to the ground, the rack may hit the ground.

Tilting the Traveler rack down:

11. Remove lynch pin clip and lynch pin to tilt the rack down for easy access to the rear of your vehicle. (Refer to Fig. 4

Fig. 9



Limited Lifetime Warranty (effective January 1, 2008):

Hollywood Racks will warrant its car racks and accessories during the time that an original retail purchaser owns the product subject to the exclusions and limitations of this warranty. Hollywood Racks will remedy defects in materials and workmanship by repairing or replacing (at its option) a defective part or the complete rack without charge for labor or parts. Hollywood Racks may elect (at its option) to issue a refund equal to the purchase price paid for the product.

This warranty does not cover problems caused by normal wear and tear including (but not limited to) weather, scratches, dents, rust, accidents, unlawful vehicle operation, misuse, abuse, neglect, theft, unauthorized modifications, or unauthorized repair. No warranty is given for defects resulting in incorrect assembly, incorrect installation onto the vehicle, installation on a "no fit" vehicle, incorrect attachment of bicycles onto the rack, or overloading of the rack's weight restrictions. This warranty terminates if the original retail purchaser transfers the product to any other person.

If a product is believed to be defective, the original retail purchaser should contact either the original retailer or Hollywood Racks directly at 800-747-4085 or at info@hollywoodracks.com

Disclaimer of Liability: Repair or replacement of a defective product or the issuance of a refund or credit (as determined by Hollywood Racks) is a purchaser's exclusive remedy under this warranty. Damage to a purchaser's vehicle, cargo, bicycles and or to any other person is excluded. This warranty is expressly made in lieu of any and all other express warranties, whether oral or written.

Hollywood Racks shall not be liable for any direct, indirect, consequential, incidental, special, punitive or any other damages in connection with the purchase, use or handling of this product.

Some states do not allow the exclusion or limitation of consequential or incidental damages and the above limitation may not apply to you. This warranty gives you specific legal rights and you have other rights, which vary from state to state.

Hollywood Racks

12812 S. Spring St. Los Angeles, CA 90061

(800) 747-4085 or (310) 516-8600 FAX (310) 516-8955

www.hollywoodracks.com info@hollywoodracks.com

Customer Service: M-F 8:00 AM – 3:00 PM PST Made in Taiwan 11218