

KOWO®

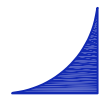
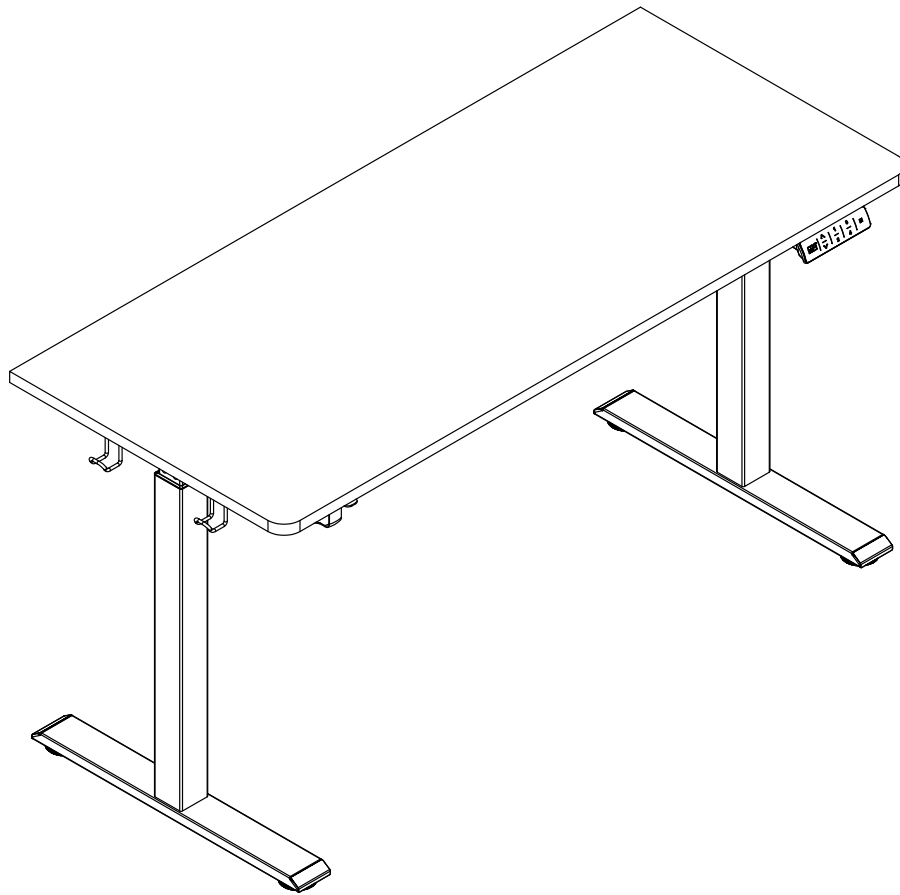

Standing Desk

Model#K3041-12/14

Any questions or issues please contact us

Tel : 020-8187-1190

Email:service.uk@kowohome.com

9:00 AM - 5:00 PM GMT Monday - Friday

Specifications

Max. Weight Capacity	100 lbs (45.4kg)
Speed	25mm/s
Input Voltage	100-240 V
Min. Height	28.7" (730mm)
Max. Height	47.2" (1200mm)
Duty Cycle	10% (Working 2 minutes then stop 18 minutes)
Certification	FCC,UKCA

Accessory Package

PLEASE NOTE: Check that you have received all components and hardware before assembling. If you are missing any parts, please contact us for replacement parts.

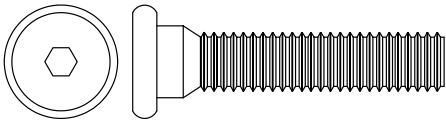

A. 1-1/2" Medium Machine Screw - 8

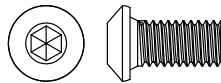

B. 1/2" Small Machine Screw - 16

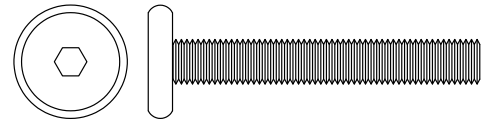

C. 2" Small Machine Screw - 2

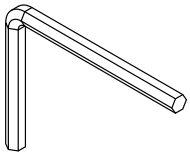

D. Wrench - 1

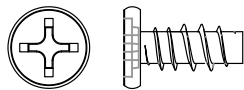

E. 1/2" Screw - 2

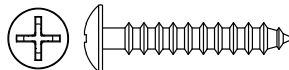

F. 1" Flat Head Screw - 3

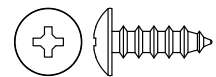

G. 5/8" Medium Wood Screw - 4

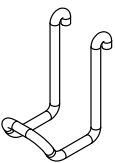

H. Hooks - 2

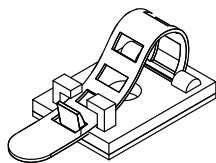

J. Self-adhesive Cable Strap - 2

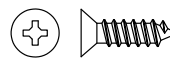

K. 1/2" Flat Head Screw - 2

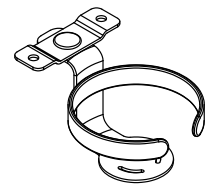

L. Cup Holder - 1

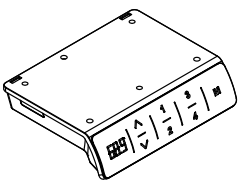

M. Control Box - 1

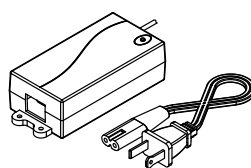

N. Power Adapter - 1

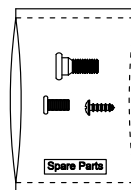

O. Spare Parts - 1

Diagram of Components

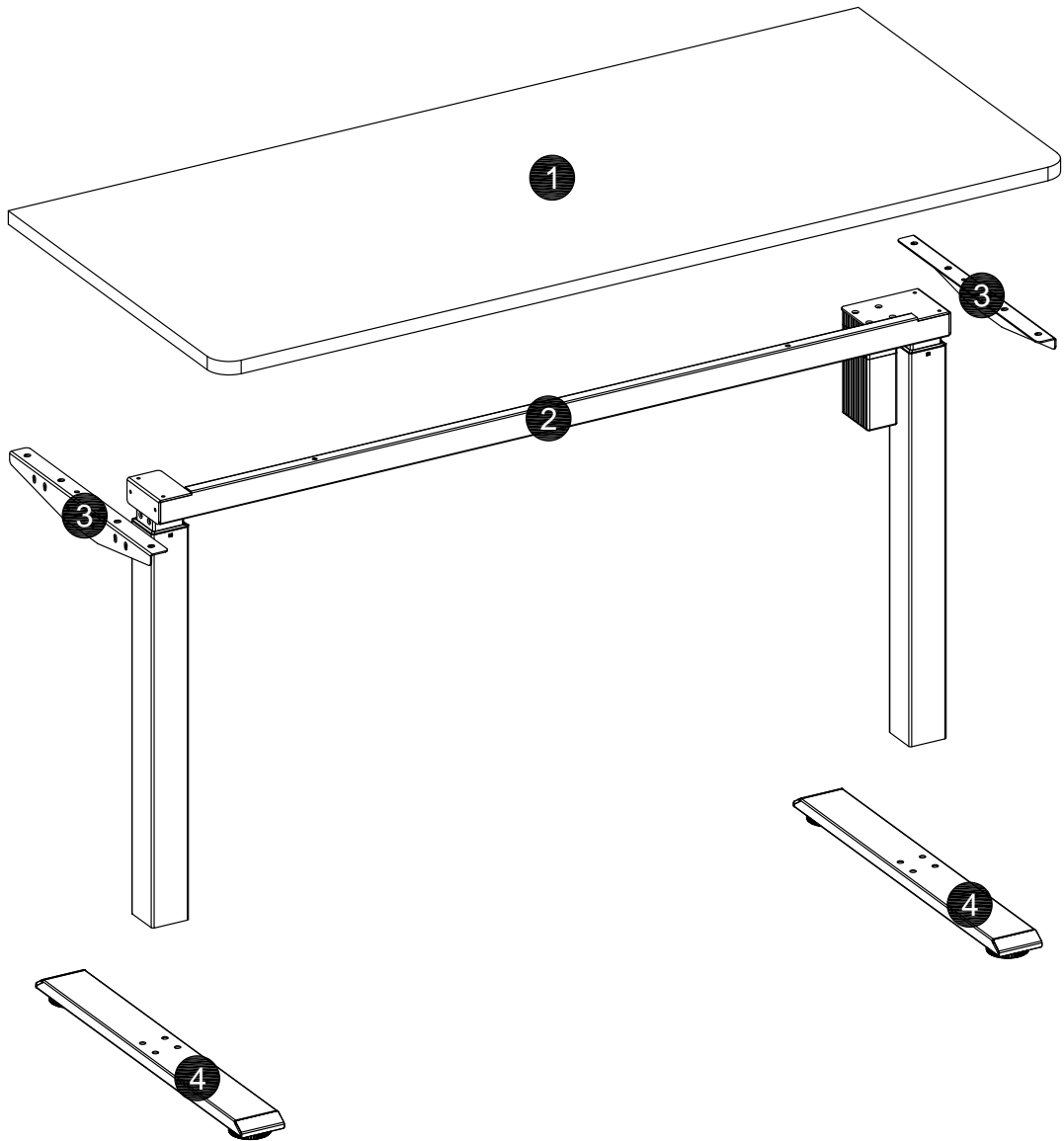

STEP 1

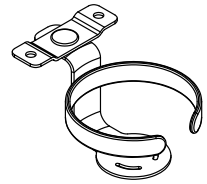
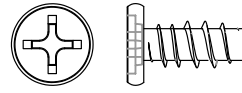
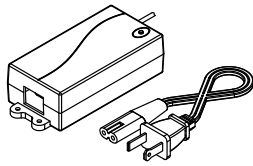
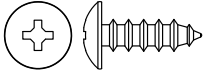

G. 5/8" Medium Wood Screw - 4

N. Power Adapter - 1

E. 1/2" Screw - 2

L. Cup Holder - 1

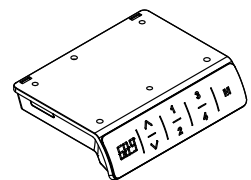
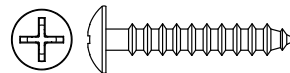
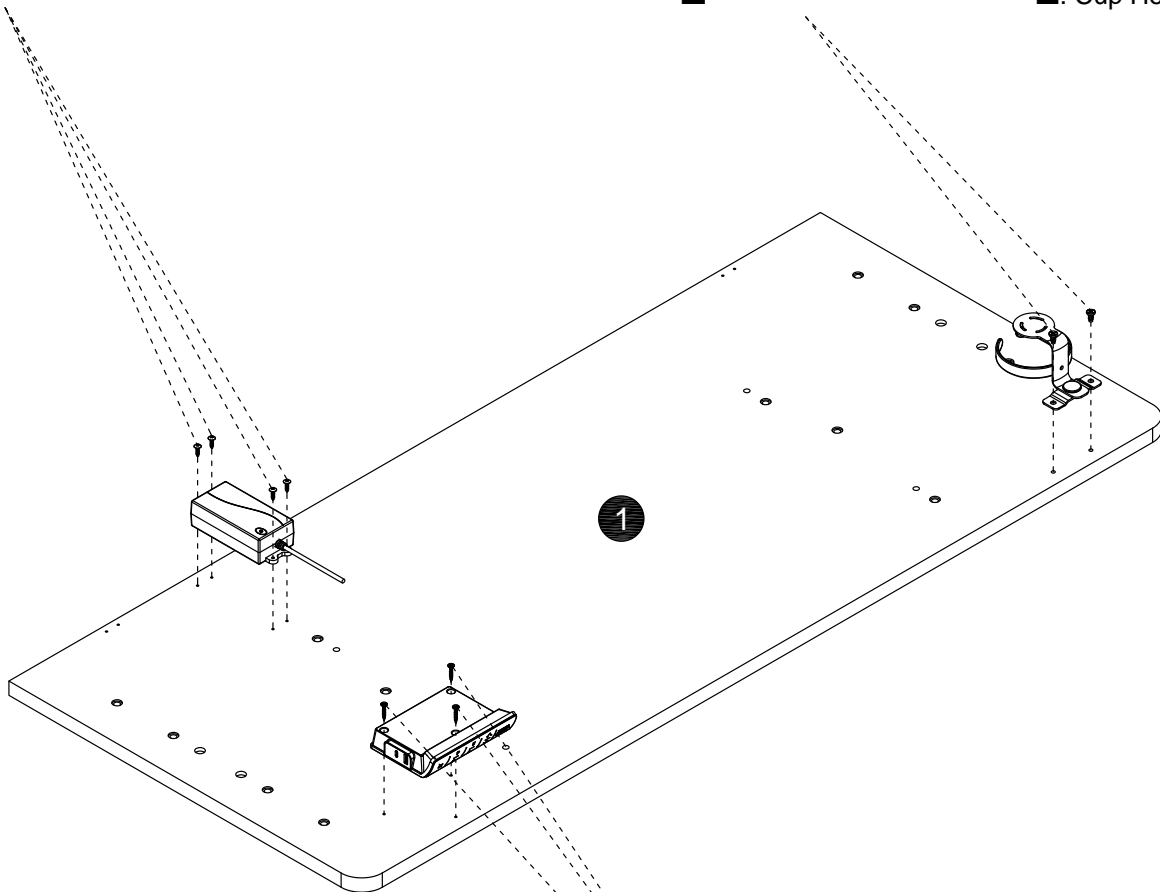

F. 1" Flat Head Screw - 3

M. Control Box - 1

STEP 2

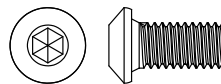
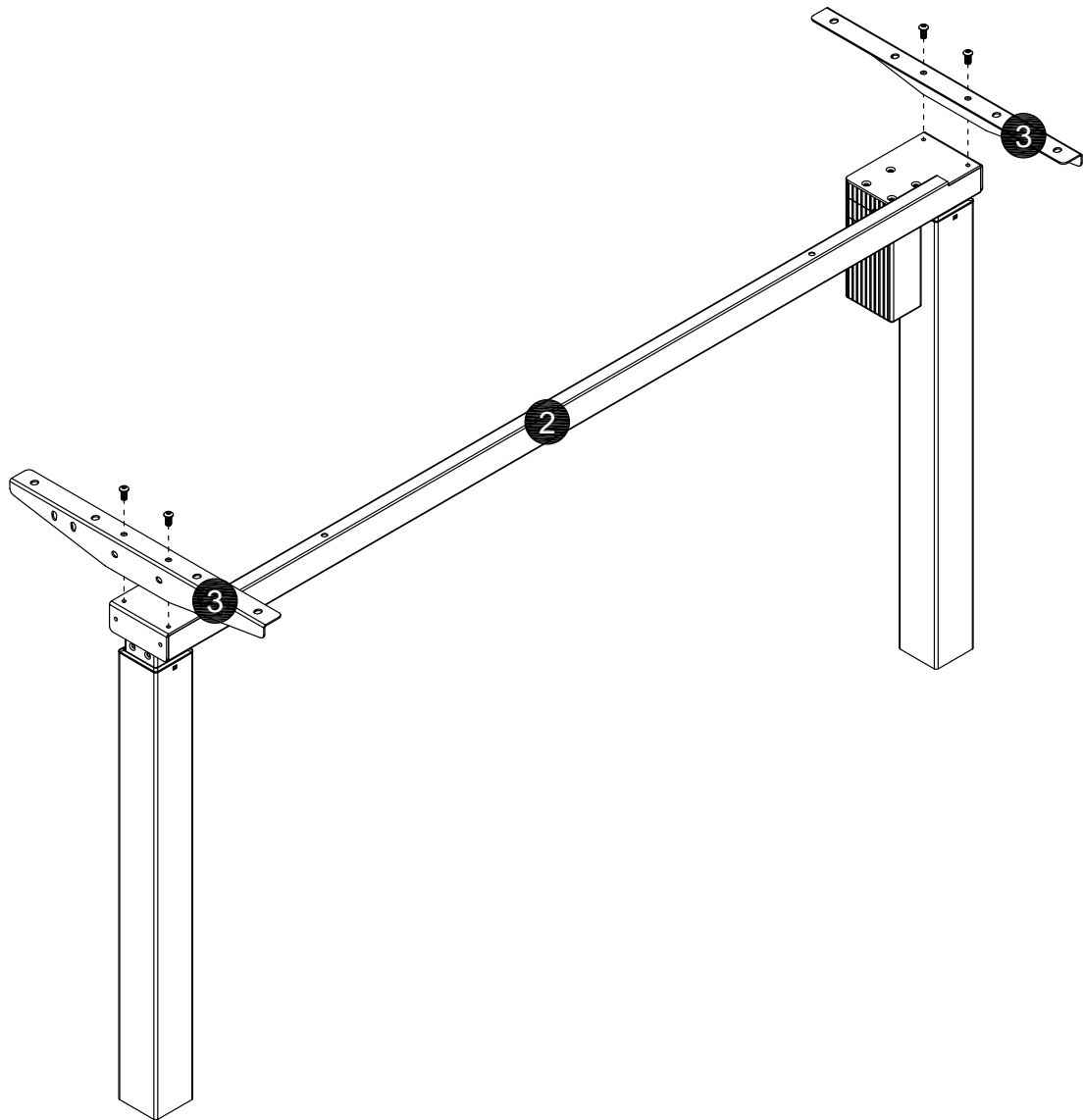

B. 1/2" Small Machine Screw - 4

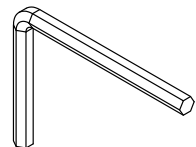

D. Wrench - 1

STEP 3

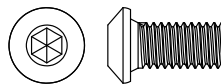
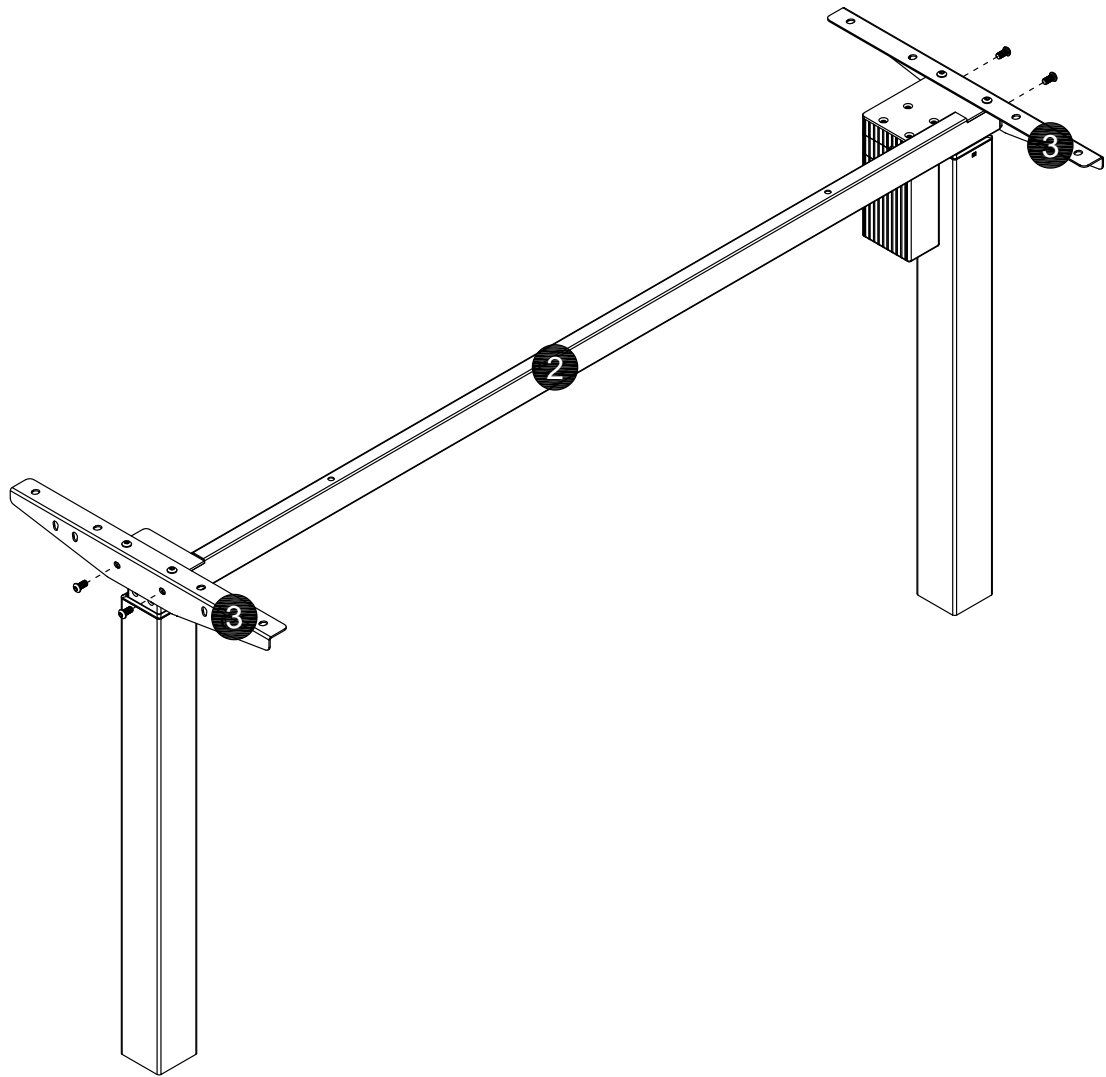

B. 1/2" Small Machine Screw - 4

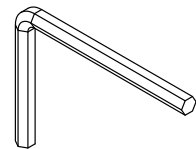

D. Wrench - 1

STEP 4

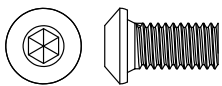
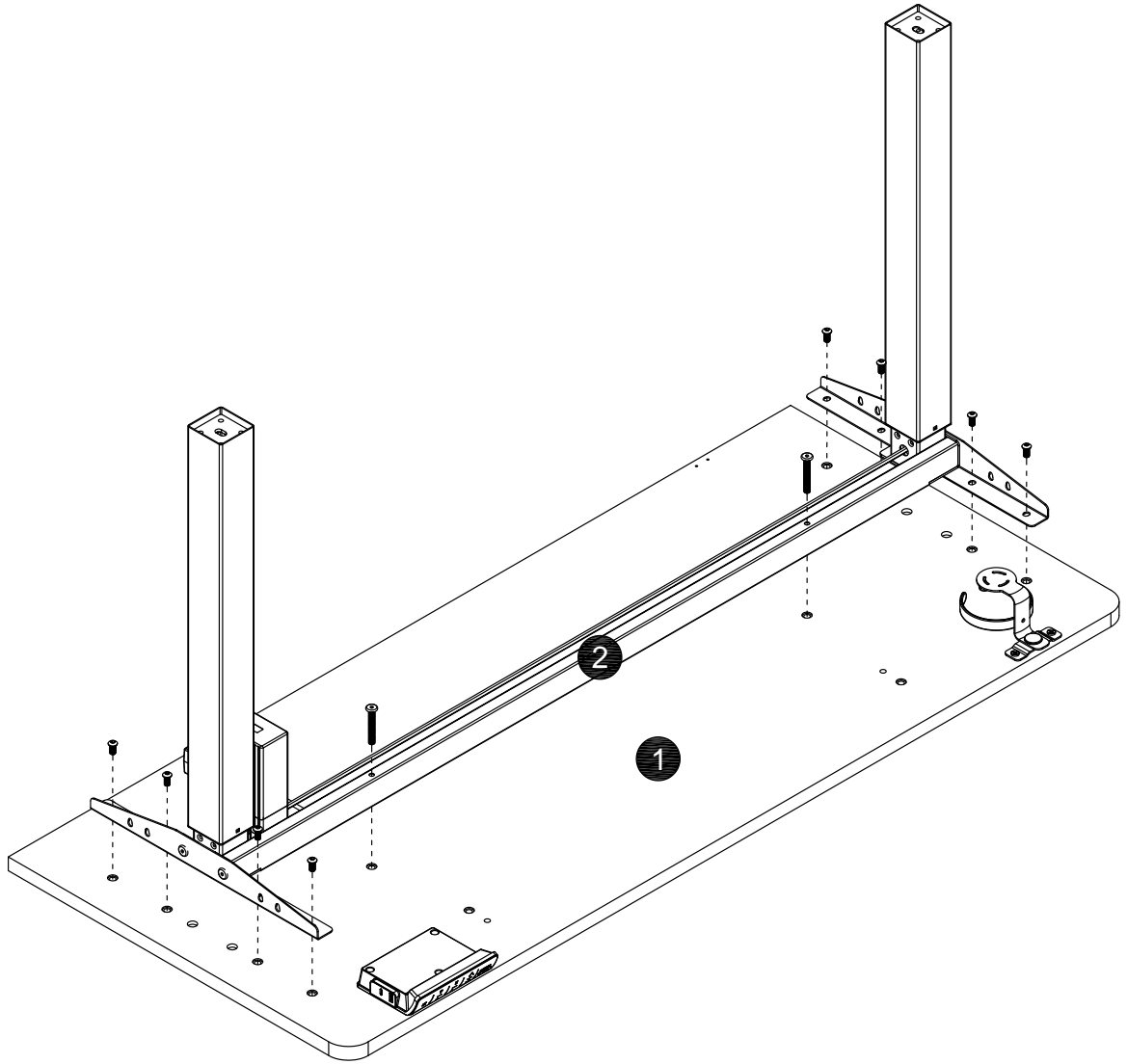

B. 1/2" Small Machine Screw - 8

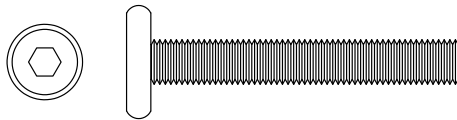

C. 2" Small Machine Screw - 2

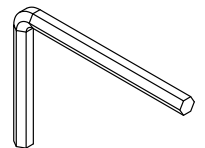

D. Wrench - 1

STEP 5

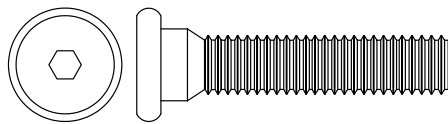
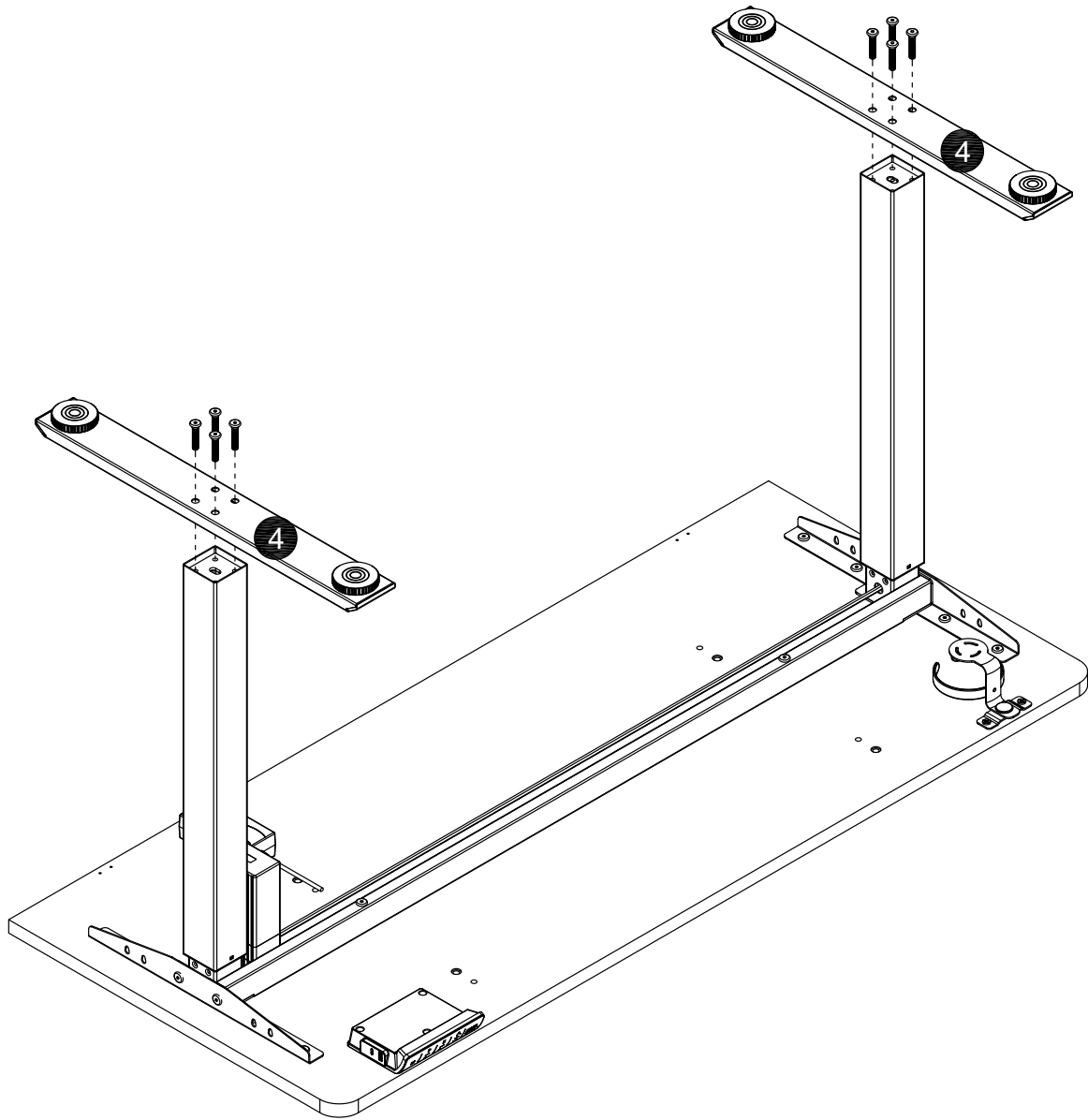

A. 3/4" Medium Machine Screw - 8

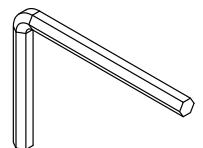

D. Wrench - 1

STEP 6

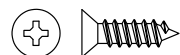
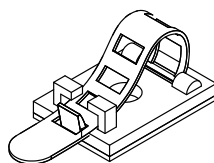
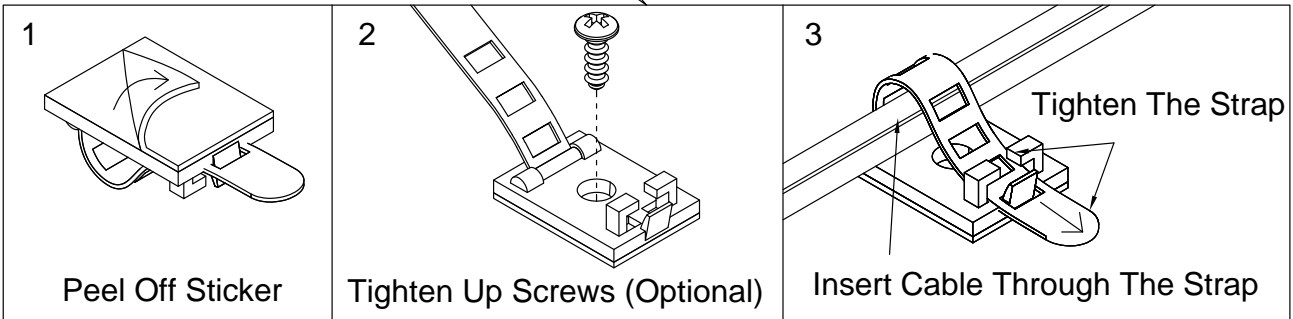
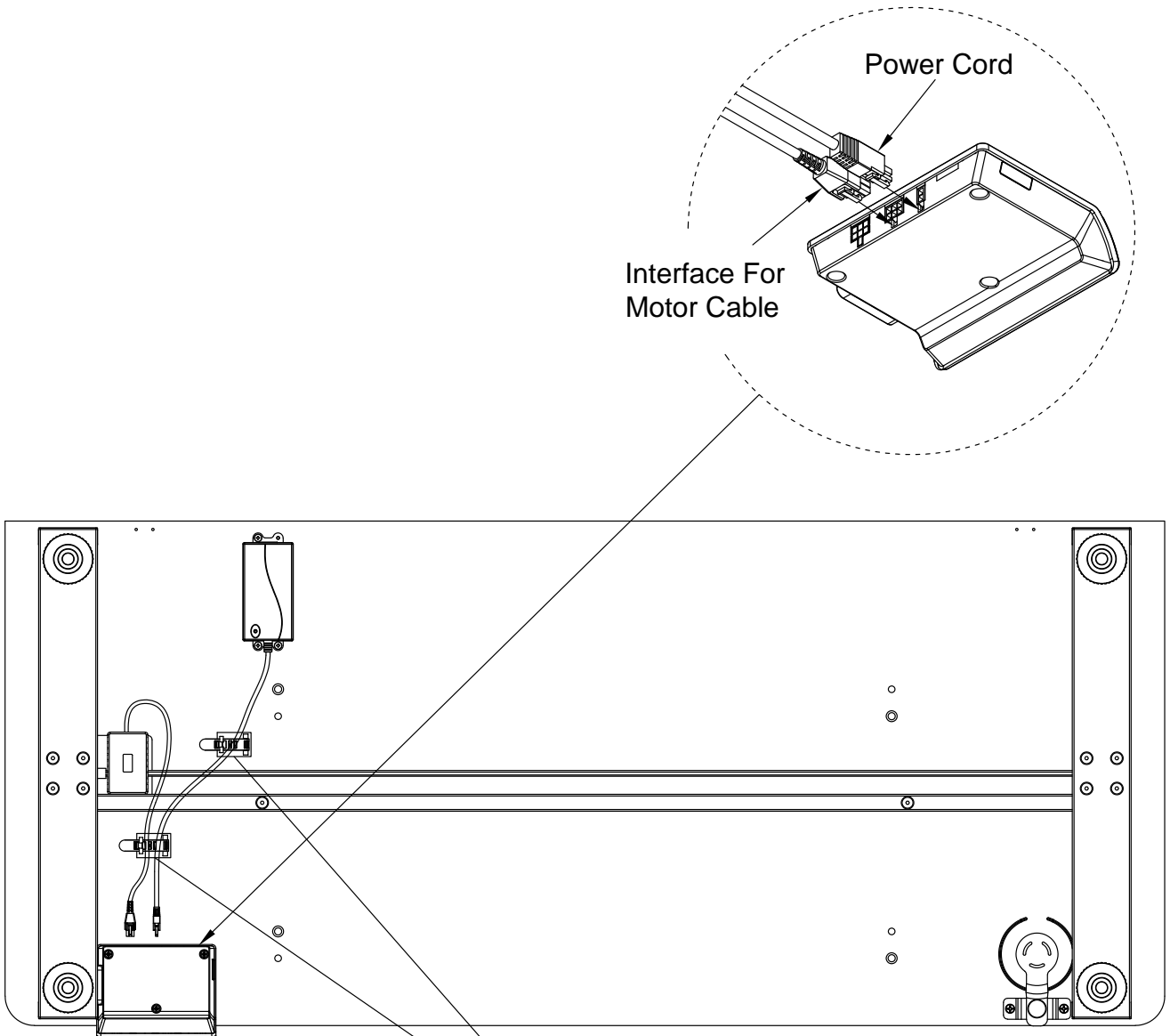

J. Self-adhesive Cable Strap - 2

K. 1/2" Flat Head Screw - 2

STEP 7

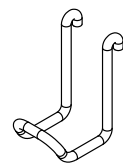
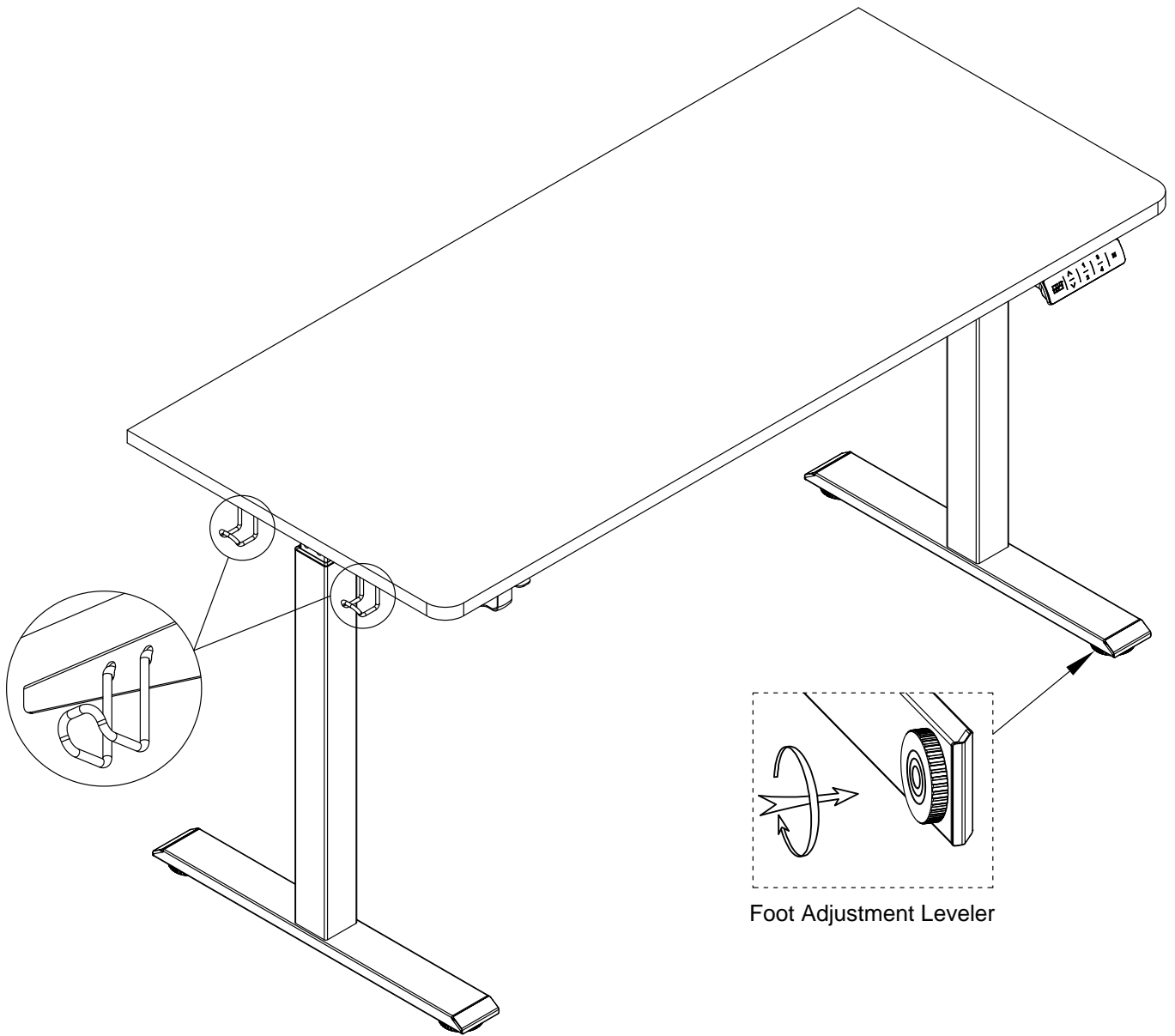

H. Hooks- 2

STEP 8

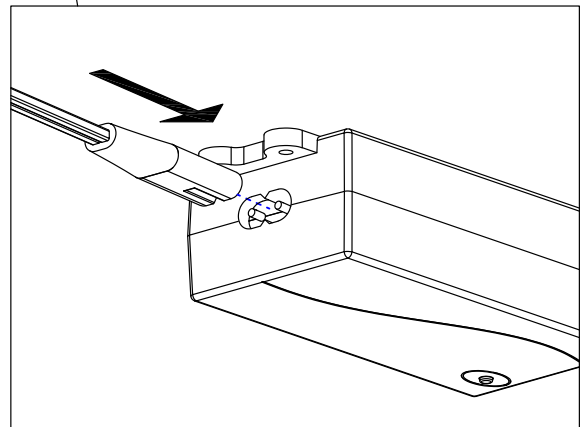
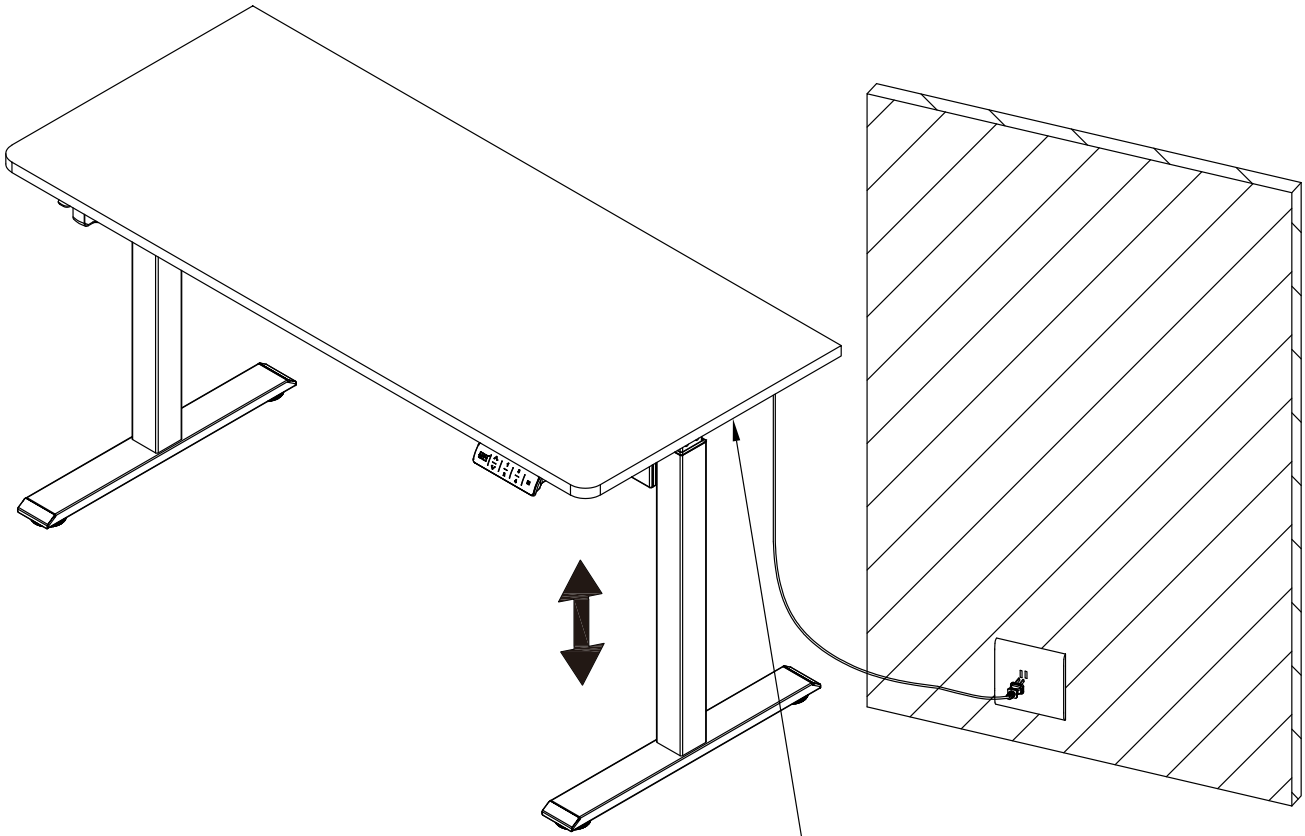

Connect Power Cable to Power Adapter

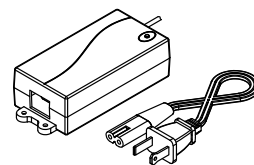

N.Power Adapter - 1

Factory reset is required for first time initialization(Page 13)

OPERATION

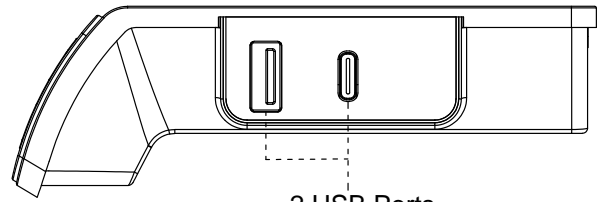
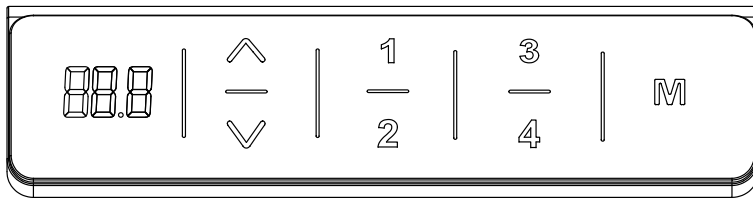

2 USB Ports

(1 Type A 5V2.4A, 1 Type C 20V1A)

While adjusting the height of your desk, the USB ports will pause charging until the height adjustment process completes.

Control Panel

-LED Digital Display

1. The LED digital display shows the height of the base. The digital display deems out automatically if there is no input after 5 seconds.
2. Press and hold the " \wedge " button to move the base and release when the base reaches the desired height. When the display shows "top", the base has reached its highest position.
2. Press and hold the " \vee " button to lower the base and release it when it reaches the desired height. The base is at the lowest position when the display shows "bot".

-The "M" (Memory) Button

1. Lock Function: To lock the current height position to prevent interruption of the height setting. Press and hold the "M" button for 3 seconds until it activates the "beep" sound and automatically sets to Lock Mode. Then, Press and hold the "M" button again until it activates the "beep" sound and returns to Unlock Mode.
2. To switch the unit of height measurement between inches and centimetres (Factory default set as inches), Press and hold the "M" and " \vee " at the same time for 3 seconds (Note: It does not work when Lock Mode is on).

-Sedentary Settings

1. To activate the Sedentary Mode, Press and hold the "M" and " \wedge " buttons at the same time for 3 seconds until the digit value (default 00) displays and flashes.
2. Press " \wedge " OR " \vee " to select 00, 10, 15, 30, 45, 60, 75, 90, 105, 120 for the countdown time setting. Re-press the "M" button to confirm and start the countdown program.
3. After the countdown starts, press the "M" button to display the remaining time of the countdown, and it disappears after it flashes five times.
4. After the Sedentary setting is completed, the current height value will display on the screen for 3 seconds by pressing any buttons. Then the remaining countdown time will display and flashes 3 times.

-Height Memory Settings

1. When the base reaches the desired height, Press and hold any one of the digit number buttons (Between "1" to "4") for 3 seconds, and the display of height value will flash 5 times, and the preset for the height is set. (The default preset setting height 30in/35in/40in/45in)
2. The desk will automatically return to the preset height when touching corresponding memory button.

TROUBLE SHOOTING

PROBLEM	ROOT CAUSE	CORRECTIVE ACTION
Display indicates E1	The motor has overheated.	Unplug the power cord and re-plug after 18 minutes. Factory reset is required.
Display indicates E2	The top load is too heavy.	Reduce the top load to a maximum of 45.4 kg (100 lbs).
	The motor is stuck.	Visually inspect whether there are any foreign materials or objects obstructing the motor and/or its shaft. Unplug the power cord for 5 minutes and then plug in again. Factory reset is required.
Display indicates E3	The motor is not powered.	Unplug the unit and visually inspect whether there are any loose electrical connections between the power cord and the adaptor, or from the adaptor to the motor. Unplug the power cord for 5 minutes and then plug in again. Factory reset is required.
Display indicates E4	Motor voltage is too low.	Make sure the power adapter is connected properly and check the power supply within the power supply range AC100V-240V Unplug the power cord for 5 minutes and then plug in again. Factory reset is required.
Display indicates RES	Desk needs to be reset to accurately display height.	A factory reset is required for the first initialization or when power is cut off due to electrical problems. Factory reset is required.
Display indicates E12	Motor failure.	Contact customer service.
Factory reset	Make sure that the cables are all connected before powering up. Press and hold the "▲" and "3" for 5 seconds after connecting to power until the RES shows on screen. The table automatically goes down until it reaches the bottom and bounce back slightly with a "beeping" sound. The "bot" message will then display on the screen. The reset process is complete.	

Recycling and Disposal



This product cannot be disposed of as household waste. To prevent damage to the environment, this product should be recycled. Please use the relevant recycling systems available to you or contact the distributor or manufacturer for recycling assistance.

Attention

- Power supply: AC100V-240V~, frequency 50/60HZ;
- Working environment: 14°F- 131°F ;
- Before cleaning, you have to unplug the power supply cable. Clean with a slightly damp cloth to wipe away the surface dust. Keep all electrical components away from liquids. Do not damage the connection line and keep the plug in a safe position.
- Inside the control box, there are electronic components, metal parts, plastic parts, wires and so on. They should be disposed in accordance with the local laws and regulations. They cannot be disposed as household waste.
- Before using the product, please make sure the product has been installed correctly.
- Before starting use of the product, please read the instructions to fully understand all the product's functions and settings.
- Keep children away from electric height-adjustable desks, control units and handsets. Manufacturer is not responsible of any damages that result from children's unpredictable behaviour.
- Slight noise caused by the multi wedge belt or brake system will not impact the use of this product.
- Do not use corrosive or abrasive materials to clean this product and please dispose of cleaning solutions in an environmentally friendly manner.
- Understand the risks associated with using this product. Children or those with cognitive impairment should not use this product without supervision.
- If the power supply cord is damaged or broken, it must be replaced by the manufacturer or a relevant specialist to avoid any injuries.
- Please operate in a clean and safe environment. For example, do not left around your tools. And always be careful to deal with packaging materials, in order to avoid any kinds of possible danger. Potential choking risk exists when children play with plastic bags!
- If necessary, retain the original package for future transportation.

FCC

This device complies with Part 15 of the FCC Rules. Operation is subject to the following two conditions:

- (1) This device may not cause harmful interference, and
- (2) This device must accept any interference received, including interference that may cause undesired operation.

Ce dispositif est conforme à la Section 15 des règles de la FCC. Son fonctionnement est soumis aux deux Conditions suivantes :

- (1) Ce produit ne risque pas de causer d'interférences électromagnétiques nuisibles, et
- (2) L'appareil doit fonctionner en dépit de tout brouillage produit, y compris le brouillage pouvant mener à une opération non désirée.

Este dispositivo cumple con la Parte 15 de las Reglas FCC. La operación está sujeta a las dos siguientes condiciones:

- (1) Este dispositivo no debe causar interferencia ,y.
- (2) Este dispositivo debe aceptar cualquier interferencia recibida, incluida interferencia que pueda causar un funcionamiento indeseable.