

EP1000

PURE EPOXY

REVISION R03.00 19.05.2021



NOTE: THIS TECHNICAL DATA SHEET REPLACES ALL PREVIOUS VERSIONS. THE INSTRUCTIONS IN THIS DOCUMENTATION ARE BASED ON OUR TESTS AND EXPERIENCE AND HAVE BEEN PREPARED TO THE BEST OF OUR KNOWLEDGE AND CONSCIENCE. DUE TO THE VARIETY OF DIFFERENT MATERIALS AND SUBSTRATES AND THE MANY DIFFERENT POSSIBLE APPLICATIONS BEYOND OUR CONTROL, WE ASSUME NO RESPONSIBILITY FOR THE RESULTS ACHIEVED. SINCE THE CONSTRUCTION AND NATURE OF THE SUBSTRATE AND THE PROCESSING CONDITIONS ARE BEYOND OUR CONTROL, WE DO NOT ACCEPT ANY LIABILITY FOR THIS PUBLICATION. IN ANY CASE, IT IS RECOMMENDED TO CARRY OUT APPROPRIATE TESTS BEFORE USE.

Content

Page

1. General	3
Product description	3
Properties and benefits	3
Applications samples	3
Handling and storage	3
Applications and intended use	4
Mortar properties	4
Reactivity	4
2. Anchorage in concrete	5
Installation instructions	5
Installation accessories	8
Setting parameter	9
Recommended loads	10
Fire resistance	16
3. Post-installed rebar	19
Installation instruction	19
Cleaning and installation tools	21
Design anchorage and lap length	24
Fire resistance - Overlapping joints	28
Fire resistance - Beam/wall or column/slab	32
4. Chemical resistance	39

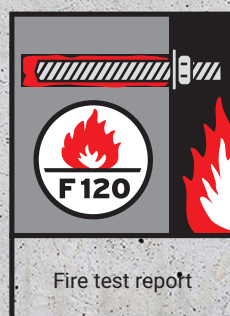
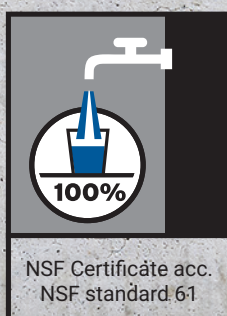
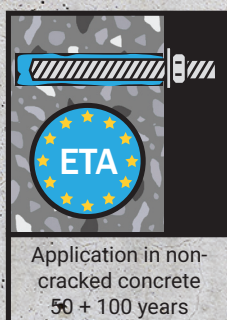

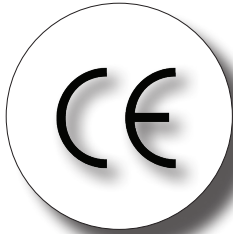

1. General

Product description

The EP1000 mortar is a 2-component reaction resin mortar based on a pure epoxy and will be delivered in a exclusive 2-C cartridge system. This high performance product may be used in combination with a hand-, battery-, or pneumatic tool and a static mixer. It was designed especially for the anchoring of threaded rods, reinforcing bars or internal threaded rod sleeves into concrete.

Properties and benefits

- European Technical Assessment for bonded fasteners acc. to EAD 330499-01-0601 (Option 1, Seismic C1 and C2, 100 years working life): ETA-19/0201
- European Technical Assessment for post-installed rebar acc. to EAD 330087-00-0601: ETA-19/0200
- Fire resistance test report acc. to DIN EN 1363-1 and Technical report TR020: EBB 21834_3
- US-approval acc. to AC 308 in concrete (ICC-ES): ESR-4246, ASTM C881
- Certificated for drinking water applications acc. to NSF Standard 61
- For heavy anchoring - doweling and post-installed rebar connection
- Overhead application
- waterfilled bore holes
- Suitable for attachment points with small edge- and axial distances due to an anchoring free of expansion forces
- High chemical resistance
- Low odour
- High bending and pressure strength
- Cartridge can be reused up to the end of the shelf life by replacing the static mixer or resealing cartridge with the sealing cap
- state-of-the-art ingredients, complies with the latest REACH regulations, free off Phenol, (CAS# 108-95-2), DETA/TETA (CAS# 111-40-0), Benzyl alcohols (CAS# 100-51-6), Bisphenol-A (CAS# 80-05-7)

Applications samples

Suitable for the fixation of facades, roofs, wood constructions, metal constructions; metal profiles, columns, beams, consoles, railings, sanitary devices, cable trays, piping, post-installed rebar connection (reconstruction or reinforcement), etc.

Handling and storage

- Storage: store in a cold and dark place, storage temperature: from +5°C up to +35 °C
- Shelf life: 24 months for cartridges (ST)

Applications and intended use

- Base material:
cracked and non-cracked concrete, light-concrete, porous-concrete, solid masonry, hollow brick, natural stone (Attention! natural stone, can discolour; shall be checked in advance).
- Anchor elements:
Threaded rods (zinc plated or hot dip, stainless steel and high corrosion resistance steel), reinforcing bars, internal threaded rods, profiled rod, steel section with undercuts (e.g. perforated section)
- Temperature range:
0°C up to +40°C installation temperature;
cartridge temperature min. +5°C; optimal +40°C;
base material temperature after full curing -40°C bis +72°C

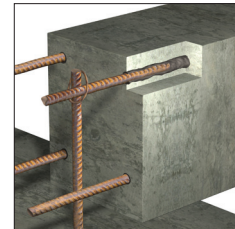
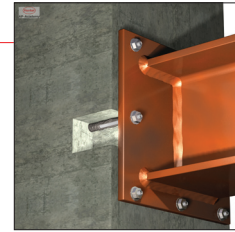

Mortar properties

Properties	Test Method	Result
UV resistance	-	Pass
Watertightness	DIN EN 12390-8	0 mm
Density	-	1,5 kg / dm ³
Compressive strength	EN 196 Teil1	122 N / mm ²
Flexural strength	EN 196 Teil1	66 N / mm ²
Axial tensile strength	DIN EN ISO 527-2	44 N / mm ²
E modulus	DIN EN ISO 527-2	6300 N / mm ²
Shrinkage	DIN 52450	< 1,4 ‰
Hardness Shore A	DIN EN ISO 868	99,4
Hardness Shore D	DIN EN ISO 868	86,1
Electrical resistance	IEC 93	8,0 * 10 ¹² Ω
Thermal conductivity	DIN EN 993-15	0,5 W / m·K
Spec. Heat capacity	DIN EN 993-15	1350 J / kg · K

Reactivity

Temperature of base material	Gelling- and working time	Full curing time in dry base material ¹⁾
0 °C to +4°C	90 min	144 h
+5 °C to +9°C	80 min	48 h
+ 10 °C to +14°C	60 min	28 h
+ 15 °C to +19°C	40 min	18 h
+ 20 °C to +24°C	30 min	12 h
+ 25 °C to +34°C	12 min	9 h
+ 35 °C to +39°C	8 min	6 h
+40°C	8 min	4 h
Cartridge temperature	+5 °C to +40 °C	

¹⁾ The curing times in wet concrete has to be doubled.

2. Anchorage in concrete

Installation instructions

Drilling of the bore hole (HD, CD; HDB)	
	<p>1a. Hammer drilling (HD) or compressed air drilling (CD). Drill a hole into the base material to the size and embedment depth required by the selected anchor (see page 8) Proceed with Step 2. In case of aborted drill hole, the drill hole shall be filled with mortar.</p>
	<p>2a. Hollow drill bit system (HDB) Drill a hole into the base material to the size and embedment depth required by the selected anchor (see page 9). This drilling system removes the dust and cleans the bore hole during drilling (all conditions). Proceed with Step 3. In case of aborted drill hole, the drill hole shall be filled with mortar.</p>
<p>Attention! Standing water must be removed before cleaning.</p>	
CAC: Cleaning for all drill hole diameter in uncracked and cracked concrete	
	<p>2a. Starting from the bottom or back of the bore hole, blow the hole clean with compressed air (min. 6 bar) (see page 8) a minimum of two times until return air stream is free of noticeable dust. If the bore hole ground is not reached an extension must be used.</p>
	<p>2b. Check brush diameter (see page 8). Brush the hole with an appropriate sized wire brush $> d_{b,min}$ (see page 8) a minimum of two times in a twisting motion. If the bore hole ground is not reached with the brush, a brush extension must be used.</p>
	<p>2c. Finally blow the hole clean again with compressed air (min. 6 bar) (see page 8) a minimum of two times until return air stream is free of noticeable dust. If the bore hole ground is not reached an extension must be used.</p>
<p>After cleaning, the bore hole has to be protected against re-contamination in an appropriate way, until dispensing the mortar in the bore hole. If necessary, the cleaning has to be repeated directly before dispensing the mortar. In-flowing water must not contaminate the bore hole again.</p>	

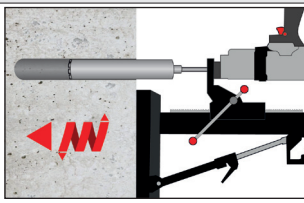
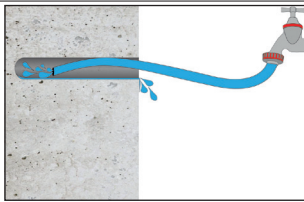
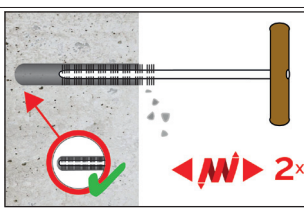
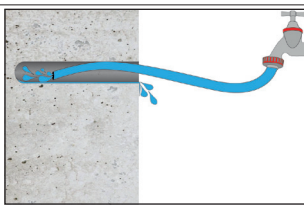
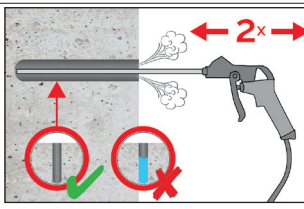
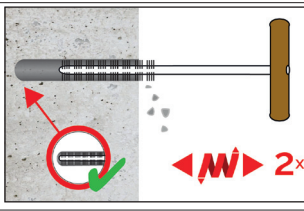
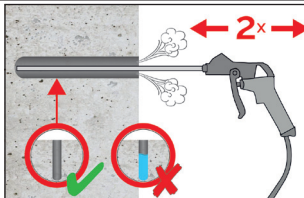
Drilling of the bore hole (DD)	
	<p>1a. Diamond drilling (DD) Drill with diamond drill a hole into the base material to the size and embedment depth required by the selected anchor (see page 9). Proceed with Step 2. In case of aborted drill hole, the drill hole shall be filled with mortar.</p>
<p>Attention! Standing water must be removed before cleaning.</p>	
<p>SPCAC: Cleaning for dry, wet and water-filled bore holes with all diameter in uncracked and cracked concrete</p>	
	<p>2a. Rinsing with water until clear water comes out.</p>
	<p>2b. Check brush diameter (see page 9). Brush the hole with an appropriate sized wire brush $> d_{b,min}$ (see page 9) a minimum of two times. If the bore hole ground is not reached with the brush, a brush extension must be used.</p>
	<p>2c. Rinsing again with water until clear water comes out.</p>
	<p>2d. Starting from the bottom or back of the bore hole, blow the hole clean with compressed air (min. 6 bar) (see page 9) a minimum of two times until return air stream is free of noticeable dust. If the bore hole ground is not reached an extension must be used.</p>
	<p>2e. Check brush diameter (see page 9). Brush the hole with an appropriate sized wire brush $> d_{b,min}$ (see page 9) a minimum of two times in a twisting motion. If the bore hole ground is not reached with the brush, a brush extension must be used.</p>
	<p>2f. Finally blow the hole clean again with compressed air (min. 6 bar) (see page 9) a minimum of two times until return air stream is free of noticeable dust. If the bore hole ground is not reached an extension must be used.</p>

	<p>3. Attach a supplied static-mixing nozzle to the cartridge and load the cartridge into the correct dispensing tool. After every working interruption longer than the recommended working time (see page 4) as well as for new cartridges, a new static-mixer shall be used.</p>
	<p>4. Prior to inserting the anchor rod into the filled bore hole, the position of the embedment depth shall be marked on the anchor rods.</p>
	<p>5. Prior to dispensing into the anchor hole, squeeze out separately a minimum of three full strokes and discard non-uniformly mixed adhesive components until the mortar shows a consistent grey or red colour.</p>
	<p>6. Starting from the bottom resp. back of the cleaned anchor hole fill the hole up to approximately two-thirds with adhesive. Slowly withdraw of the static mixing nozzle as the hole is filled avoids creating air pockets. If the bore hole ground is not reached with the static-mixing nozzle, a appropriate extension must be used. Observe the gel-/ working times given (see page 4).</p>
	<p>7. Piston plugs shall be used acc. to table on page 9 for the following application:</p> <ul style="list-style-type: none"> • Horizontal assembly (horizontal direction) and ground erection (vertical downwards): Drill bit-$\varnothing d_0 \geq 18$ mm and embedment depth $h_{ef} > 250$mm • Overhead assembly (vertical upwards direction): Drill bit-$\varnothing d_0 \geq 18$ mm.
	<p>8. Insert piston plug to back of the hole and inject adhesive. If the bottom or back of the anchor hole is not reached, an appropriate extension nozzle must be used. During injection the piston plug is naturally pushed out of the bore-hole by the back pressure of the mortar. Observe the gel-/working times given in the table on page 4.</p>
	<p>9. Push the fixing element into the anchor hole while turning slightly to ensure positive distribution of the adhesive until the embedment mark has reached the surface level.</p>
	<p>The anchor should be free of dirt, grase, oil or other foreign material.</p>
	<p>10. After inserting the anchor, the annular gab between anchor rod and concrete, in case of a push through installation additionally also the fixture, must be complete filled with mortar. If excess mortar is not visible at the top of the hole, the requirement is not fulfilled and the application has to be renewed.</p>
	<p>11. For overhead application the anchor rod shall be fixed (e. g. wedges) until the mortar has started to harden.</p>

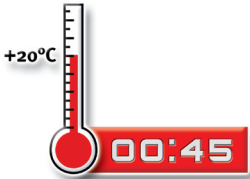
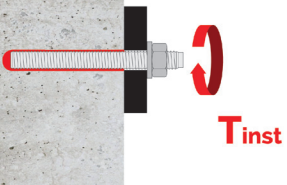
- | | |
|---|---|
|  | <p>12. Allow the adhesive to cure to the specified time prior to applying any load or torque. Do not move or load the anchor until it is fully cured (see page 4).</p> |
|  | <p>13. After full curing, the add-on part can be installed with up to the max. torque (see page 9) by using a calibrated torque wrench. It can be optional filled the annular gap between anchor and fixture with mortar. Therefor substitute the washer by the filling washer and connect the mixer reduction nozzle to the tip of the mixer. The annular gap is filled with mortar, when mortar oozes out of the washer.</p> |

Installation accessories

CAC - Rec. compressed air tool (min 6 bar)
 Drill bit diameter (d_0): all diameters







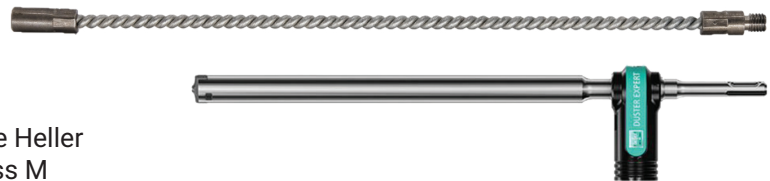

Brush RBT and brush extension



HDB – Hollow drill bit system
 Drill bit diameter (d_0): all diameters
 The hollow drill bit system contains the Heller Duster Expert hollow drill bit and a class M vacuum with minimum negative pressure of 253 hPa and flow rate of minimum 150 m³/h (42 l/s).

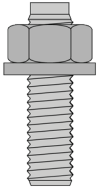

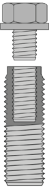
Threaded rod	Rebar	Internal threaded Anchor rod	Drill bit - \varnothing HD	Brush			Piston plug	Installation direction and use of piston plug		
				d_b Brush- \varnothing	$d_{b,min}$ min. Brush- \varnothing					
[mm]	[mm]	[mm]	[mm]	[-]	[mm]	[mm]	[-]			
M8	8	-	10	RBT 10	11,5	10,5	No piston plug required			
M10	8 / 10	IG-M6	12	RBT 12	13,5	12,5				
M12	10 / 12	IG-M8	14	RBT 14	15,5	14,5				
-	12	-	16	RBT 16	17,5	16,5				
M16	14	IG-M10	18	RBT 18	20,0	18,5	VS 18	$h_{ef} > 250$ mm	$h_{ef} > 250$ mm	all
-	16	-	20	RBT 20	22,0	20,5	VS 20			
M20	-	IG-M12	22	RBT 22	24,0	22,5	VS 22			
-	20	-	25	RBT 25	27,0	25,5	VS 25			

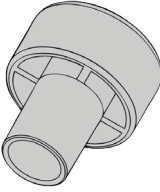
										
Threaded rod	Rebar	Internal threaded Anchor rod	Drill bit - Ø HD	d _b Brush-Ø		d _{b,min} min. Brush-Ø	Piston plug	Installation direction and use of piston plug		
[mm]	[mm]	[mm]	[mm]	[-]	[mm]	[mm]	[-]	↓	→	↑
M24	-	IG-M16	28	RBT 28	30,0	28,5	VS 28	h _{ef} > 250 mm	h _{ef} > 250 mm	all
M27	24 / 25	-	30	RBT 30	31,8	30,5	VS 30			
-	24 / 25	-	32	RBT 32	34,0	32,5	VS 32			
M30	28	IG-M20	35	RBT 35	37,0	35,5	VS 35			
-	32	-	40	RBT 40	43,5	40,5	VS 40			
M33	-	-	38	RBT 38	40,0	38,8	VS 38			
M36	-	-	42	RBT 42	44,0	42,8	VS 42			
-	36	-	45	RBT 45	47,0	45,8	VS 45			
M39	-	-	45	RBT 45	47,0	45,8	VS 45			
-	40	-	50	RBT 50	52,0	50,8	VS 50			
M42	-	-	52	RBT 52	54,0	52,8	VS 52			
M48	-	-	60	RBT 60	62,0	60,8	VS 60			

Setting parameter

Anchor size			M8	M10	M12	M16	M20	M24	M27	M30	M33	M36	M39	M42	M48	
Outer diameter of anchor	d = d _{nom}	[mm]	8	10	12	16	20	24	27	30	33	36	39	42	48	
Nominal drill hole diameter	d ₀	[mm]	10	12	14	18	22	28	30	35	38	42	45	52	60	
Effective embedment depth	h _{ef,min}	[mm]	60	60	70	80	90	96	108	120	132	144	156	168	192	
	h _{ef,max}	[mm]	160	200	240	320	400	480	540	600	660	720	780	840	960	
Diameter of clearance hole in the fixture ¹⁾	Pre-positioned anchorage d _f	[mm]	9	12	14	18	22	26	30	33	36	39	42	45	52	
	In-place anchorage d _f	[mm]	12	14	16	20	24	30	33	40	40	44	47	54	62	
Maximum torque moment	T _{inst} ≤	[Nm]	10	20	35	60	100	170	250	300	330	360	390	460	550	
Minimum thickness of member	h _{min}	[mm]	h _{ef} + 30 mm ≥ 100 mm				h _{ef} + 2d ₀									
Minimum spacing	S _{min}	[mm]	40	50	60	75	95	115	125	140	165	180	195	210	240	
Minimum edge distance	C _{min}	[mm]	35	40	45	50	60	65	75	80	165	180	195	210	240	

¹⁾ When used under seismic load, the diameter of the through hole in fixture must not exceed d_f + 1 mm or alternatively, the annular gap between the fixture and the anchor rod must be force-filled with mortar.

Rebar size			ø8 ¹⁾	ø10 ¹⁾	ø12 ¹⁾	ø14	ø16	ø20	ø24 ¹⁾	ø25 ¹⁾	ø28	ø32	ø36	ø40
Outer diameter of anchor	$d = d_{nom}$ [mm]		8	10	12	14	16	20	25	25	28	32	36	40
Nominal drill hole diameter	d_0 [mm]		10 12	12 14	14 16	18	20	25	30 32	30 32	35	40	45	50
Effective embedment depth	$h_{ef,min}$ [mm]		60	60	70	75	80	90	96	100	112	128	144	240
	$h_{ef,max}$ [mm]		160	200	240	280	320	400	480	500	560	640	720	800
Minimum thickness of member	h_{min} [mm]		$h_{ef} + 30 \text{ mm} \geq 100 \text{ mm}$			$h_{ef} + 2d_0$								
Minimum spacing	S_{min} [mm]		40	50	60	70	75	95	120	120	130	150	180	200
Minimum edge distance	C_{min} [mm]		35	40	45	50	50	60	70	70	75	85	180	200

¹⁾ Both nominal drill hole diameters d_0 can be used.

Size internal threaded anchor rod			IG-M6	IG-M8	IG-M10	IG-M12	IG-M16	IG-M20
Internal diameter of anchor	d_2 [mm]		6	8	10	12	16	20
Outer diameter of anchor ¹⁾	$d = d_{nom}$ [mm]		10	12	16	20	24	30
Nominal drill hole diameter	d_0 [mm]		12	14	18	22	28	35
Effective embedment depth	$h_{ef,min}$ [mm]		60	70	80	90	96	120
	$h_{ef,max}$ [mm]		200	240	320	400	480	600
Diameter of clearance hole in the fixture	d_f [mm]		7	9	12	14	18	22
Maximum torque moment	T_{inst} [Nm]		10	10	20	40	60	100
Thread engagement length (min/max)	l_{IG} [mm]		8/20	8/20	10/25	12/30	16/32	20/40
Minimum thickness of member	h_{min} [mm]		$h_{ef} + 30 \text{ mm} \geq 100 \text{ mm}$			$h_{ef} + 2d_0$		
Minimum spacing	s_{min} [mm]		50	60	75	95	115	140
Minimum edge distance	c_{min} [mm]		40	45	50	60	65	80

¹⁾ With metric threads according to EN 1993-1-8:2005+AC:2009

Recommended loads

Threaded rod

The recommended loads are only valid for single anchors for a roughly design, if the following conditions are valid:

- $c \geq 1,5 \times h_{ef}$ $s \geq 3,0 \times h_{ef}$ $h \geq 2 \times h_{ef}$
- $\psi_{sus} = 1,0$; percentage of dead load $\leq \psi_{sus}^0$ see table below
- The recommended loads have been calculated using the partial safety factors for resistances stated in the ETA and with a partial safety factor for actions of $\gamma_f=1.4$.
The partial safety factor for seismic action is $\gamma_1 = 1,0$.

If the conditions are not fulfilled the loads must be calculated acc. to EN 1992-4.

For further details observe ETA-19/0201.

Recommended loads for a working life of 50 years					M8	M10	M12	M16	M20	M24	M27	M30	M33 ⁴⁾	M36 ⁴⁾	M39 ⁴⁾	M42 ⁴⁾	M48 ⁴⁾	
<ul style="list-style-type: none"> Property class 8.8 Concrete - C20/25 Hammer- (HD) and compressed air drilling (CD) dry, wet concrete 																		
Recommended tension load	40°C / 24°C ¹⁾ $\psi_{sus}^0 = 0,80$	uncracked	$N_{rec,stat}$	[kN]	13,8	20,0	27,0	32,7	51,9	71,3	92,6	103,9	111,7	127,8	144,6	168,0	205,3	
		cracked	$N_{rec,stat}$	[kN]	6,7	9,4	16,8	22,9	36,3	49,9	64,8	72,7	78,2	89,5	101,2	117,6	143,7	
			$N_{rec,eq,C1}$	[kN]	6,7	9,4	16,8	22,9	36,3	49,9	64,8	72,7	NPA					
			$N_{rec,eq,C2}$	[kN]	NPA	NPA	16,0	20,1	35,6	49,9	NPA	NPA						
	72°C / 50°C ¹⁾ $\psi_{sus}^0 = 0,68$	uncracked	$N_{rec,stat}$	[kN]	13,8	20,0	27,0	32,7	51,9	71,3	92,6	103,9	NPA					
		cracked	$N_{rec,stat}$	[kN]	5,7	8,1	13,8	20,9	35,6	49,9	64,8	72,7						
			$N_{rec,eq,C1}$	[kN]	5,7	8,1	13,8	20,9	35,6	49,9	64,8	72,7						
			$N_{rec,eq,C2}$	[kN]	NPA	NPA	13,8	17,2	30,6	46,4	NPA	NPA						
Recommended shear load without lever arm ^{2) 3)}	uncracked	$V_{rec,stat}$	[kN]	8,6	11,9	16,5	20,8	34,1	48,1	63,5	72,3	93,3	106,1	120,3	140,4	174,6		
		$V_{rec,stat}$	[kN]	6,9	8,4	11,7	14,8	24,2	34,0	45,0	51,2	66,1	75,2	85,2	99,5	123,7		
	cracked	$V_{rec,eq,C1}$	[kN]	6,9	8,4	11,7	14,8	24,2	34,0	45,0	51,2	NPA						
		$V_{rec,eq,C2}$	[kN]	NPA	NPA	11,7	14,8	24,2	34,0	NPA	NPA							
Embedment depth	h_{ef}	[mm]	80	90	110	125	170	210	250	270	320	350	380	420	480			
Edge distance	$c \geq$	[mm]	120	135	165	187,5	255	315	375	405	480	525	570	630	720			
Axial distance	$s \geq$	[mm]	240	270	330	375	510	630	750	810	960	1050	1140	1260	1440			

1) Short term temperature/ Long term temperature.

2) Shear loads are valid for all specified temperature ranges.

3) In case of seismic action, the annular gap between the anchor rod and the through hole of the attachment must be filled with mortar, otherwise $\alpha_{gap} = 0,5$ acc. to ETA-19/0201 must be taken into account.

4) Application is not covered by the ETA-19/0201.

$N_{rec,stat}$ $V_{rec,stat}$ = Recommended load under static and quasi-static action

$N_{rec,eq}$ $V_{rec,eq}$ = Recommended load under seismic action

NPA = no performance accessed

Recommended loads for a working life of 50 years					M8	M10	M12	M16	M20	M24	M27	M30	M33 ⁴⁾	M36 ⁴⁾	M39 ⁴⁾	M42 ⁴⁾	M48 ⁴⁾	
<ul style="list-style-type: none"> Property class 8.8 Concrete - C20/25 Diamond drilling (DD) dry, wet concrete 																		
Recommended tension load	40°C / 24°C ¹⁾ $\psi_{sus}^0 = 0,77$	uncracked	$N_{rec,stat}$	[kN]	13,8	18,8	27,0	32,7	51,9	71,3	92,6	103,9	111,7	127,8	144,6	168,0	205,3	
	72°C / 50°C ¹⁾ $\psi_{sus}^0 = 0,72$	uncracked	$N_{rec,stat}$	[kN]	11,5	16,2	21,7	29,9	48,3	71,3	90,9	103,9	NPA					
Recommended shear load without lever arm ^{2) 3)}	uncracked	$V_{rec,stat}$	[kN]	8,6	11,9	16,5	20,8	34,1	48,1	63,5	72,3	93,3	106,1	120,3	140,4	174,6		

Recommended loads for a working life of 50 years			M8	M10	M12	M16	M20	M24	M27	M30	M33 ⁴⁾	M36 ⁴⁾	M39 ⁴⁾	M42 ⁴⁾	M48 ⁴⁾
<ul style="list-style-type: none"> Property class 8.8 Concrete - C20/25 Diamond drilling (DD) dry, wet concrete 															
Embedment depth	h_{ef}	[mm]	80	90	110	125	170	210	250	270	320	350	380	420	480
Edge distance	$c \geq$	[mm]	120	135	165	188	255	315	375	405	480	525	570	630	720
Axial distance	$s \geq$	[mm]	240	270	330	375	510	630	750	810	960	1050	1140	1260	1440

- 1) Short term temperature/ Long term temperature.
- 2) Shear loads are valid for all specified temperature ranges.
- 3) In case of seismic action, the annular gap between the anchor rod and the through hole of the attachment must be filled with mortar, otherwise $\alpha_{gap} = 0,5$ acc. to ETA-19/0201 must be taken into account.
- 4) Application is not covered by the ETA-19/0201.

$N_{rec,stat}, V_{rec,stat}$ = Recommended load under static and quasi-static action

$N_{rec,eq}, V_{rec,eq}$ = Recommended load under seismic action

Internal threaded rod

The recommended loads are only valid for single anchors for a roughly design, if the following conditions are valid:

- $c \geq 1,5 \times h_{ef}$ $s \geq 3,0 \times h_{ef}$ $h \geq 2 \times h_{ef}$
- $\psi_{sus} = 1,0$; percentage of dead load $\leq \psi_{sus}^0$ see table below
- The recommended loads have been calculated using the partial safety factors for resistances stated in the ETA and with a partial safety factor for actions of $\gamma_f=1.4$.
The partial safety factor for seismic action is $\gamma_1 = 1,0$.

If the conditions are not fulfilled the loads must be calculated acc. to EN 1992-4.

For further details observe ETA-19/0201.

Recommended loads for a working life of 50 years			IG-M6	IG-M8	IG-M10	IG-M12	IG-M16	IG-M20	
<ul style="list-style-type: none"> Property class 8.8 Concrete - C20/25 Hammer- (HD) and compressed air drilling (CD) dry, wet concrete 									
Recommended tension load	40°C / 24°C ¹⁾	uncracked	$N_{rec,stat}$ [kN]	7,6	13,8	21,9	31,9	57,6	93,3
		cracked	$N_{rec,stat}$ [kN]	7,6	13,8	21,9	31,9	49,9	76,8
	72°C / 50°C ¹⁾	uncracked	$N_{rec,stat}$ [kN]	7,6	13,8	21,9	31,9	57,6	93,3
		cracked	$N_{rec,stat}$ [kN]	7,6	13,8	20,9	31,9	49,9	76,8
Recommended shear load without lever arm ^{2) 3)}	uncracked	$V_{rec,stat}$ [kN]	6,4	12,0	18,4	27,2	48,8	78,4	
	cracked	$V_{rec,stat}$ [kN]	4,6	8,6	13,1	19,4	34,9	54,1	
Embedment depth	h_{ef}	[mm]	90	110	125	170	210	280	
Edge distance	$c \geq$	[mm]	165	188	255	315	420	420	
Axial distance	$s \geq$	[mm]	330	375	510	630	840	840	

- 1) Short term temperature/ Long term temperature.
- 2) Shear loads are valid for all specified temperature ranges.
- 3) In case of seismic action, the annular gap between the anchor rod and the through hole of the attachment must be filled with mortar, otherwise $\alpha_{gap} = 0,5$ acc. to ETA-19/0201 must be taken into account.

$N_{rec,stat}, V_{rec,stat}$ = Recommended load under static and quasi-static action

$N_{rec,eq}, V_{rec,eq}$ = Recommended load under seismic action

Recommended loads for a working life of 50 years					IG-M6	IG-M8	IG-M10	IG-M12	IG-M16	IG-M20
<ul style="list-style-type: none"> • Property class 8.8 • Concrete - C20/25 • Diamond drilling (DD) • dry, wet concrete 										
Recommended tension load	40°C / 24°C ¹⁾ $\psi_{sus}^0 = 0,77$	uncracked	$N_{rec,stat}$	[kN]	7,6	13,8	21,9	31,9	57,6	93,3
	72°C / 50°C ¹⁾ $\psi_{sus}^0 = 0,72$	uncracked	$N_{rec,stat}$	[kN]	7,6	13,8	21,9	31,9	57,6	93,3
Recommended shear load without lever arm ^{2) 3)}		uncracked	$V_{rec,stat}$	[kN]	4,6	8,6	13,1	19,4	34,9	56,0
Embedment depth			h_{ef}	[mm]	90	110	125	170	210	280
Edge distance			$c \geq$	[mm]	165	188	255	315	420	420
Axial distance			$s \geq$	[mm]	330	375	510	630	840	840

¹⁾ Short term temperature/ Long term temperature.

²⁾ Shear loads are valid for all specified temperature ranges.

³⁾ In case of seismic action, the annular gap between the anchor rod and the through hole of the attachment must be filled with mortar, otherwise $\alpha_{gap} = 0,5$ acc. to ETA-19/0201 must be taken into account.

$N_{rec,stat}$ $V_{rec,stat}$ = Recommended load under static and quasi-static action

$N_{rec,eq}$ $V_{rec,eq}$ = Recommended load under seismic action

Rebar

The recommended loads are only valid for single anchors for a roughly design, if the following conditions are valid:

- $c \geq 1,5 \times h_{ef}$ $s \geq 3,0 \times h_{ef}$ $h \geq 2 \times h_{ef}$
- $\psi_{SUS} = 1,0$; percentage of dead load $\leq \psi_{SUS}^0$ see table below
- The recommended loads have been calculated using the partial safety factors for resistances stated in the ETA and with a partial safety factor for actions of $\gamma_f=1.4$.
The partial safety factor for seismic action is $\gamma_1 = 1,0$.

If the conditions are not fulfilled the loads must be calculated acc. to EN 1992-4.
For further details observe ETA-19/0200.

Recommended loads for a working life of 50 years			Ø8	Ø10	Ø12	Ø14	Ø16	Ø20	Ø24	Ø25	Ø28	Ø32	Ø36 ⁴⁾	Ø40 ⁴⁾		
• Property class BSt 500 • Concrete - C20/25 • Hammer- (HD) and compressed air drilling (CD) • dry, wet concrete																
Recommended tension load	40°C / 24°C ¹⁾ $\psi_{SUS}^0 = 0,80$	uncracked	$N_{rec,stat}$ [kN]	14,3	20,0	27,0	28,9	32,7	51,9	68,8	71,3	92,6	103,9	127,8	144,6	
		cracked	$N_{rec,stat}$ [kN]	6,7	9,4	16,8	20,2	22,9	36,3	48,1	49,9	64,8	72,7	89,5	101,2	
	$N_{rec,eq,C1}$ [kN]		6,7	9,4	16,8	20,2	22,9	36,3	48,1	49,9	64,8	72,7	NPA			
	72°C / 50°C ¹⁾ $\psi_{SUS}^0 = 0,68$	uncracked	$N_{rec,stat}$ [kN]	11,5	16,2	23,7	28,9	32,7	51,9	68,8	71,3	92,6				103,9
		cracked	$N_{rec,stat}$ [kN]	5,7	8,1	13,8	16,9	20,9	35,6	48,1	49,9	64,8				72,7
	$N_{rec,eq,C1}$ [kN]		5,7	8,1	13,8	16,9	20,9	35,6	48,1	49,9	64,8	72,7				
Recommended shear load without lever arm ^{2) 3)}	uncracked	$V_{rec,stat}$ [kN]	6,7	10,5	14,8	18,0	20,8	34,1	46,4	48,4	63,8	73,0	106,1	121,3		
		$V_{rec,stat}$ [kN]	6,7	8,4	11,7	12,8	14,8	24,2	32,8	34,3	45,2	51,7	75,2	86,0		
	cracked	$V_{rec,eq,C1}$ [kN]	6,5	8,4	11,7	12,8	14,8	24,2	32,8	34,3	45,2	36,2	NPA			
Embedment depth	h_{ef} [mm]	80	90	110	115	125	170	205	210	250	270	350	380			
Edge distance	$c \geq$ [mm]	120	135	165	173	188	255	308	315	375	405	525	570			
Axial distance	$s \geq$ [mm]	240	270	330	345	375	510	615	630	750	810	1050	1140			

- 1) Short term temperature/ Long term temperature.
- 2) Shear loads are valid for all specified temperature ranges.
- 3) In case of seismic action, the annular gap between the anchor rod and the through hole of the attachment must be filled with mortar, otherwise $\alpha_{gap} = 0,5$ acc. to ETA-19/0200 must be taken into account.
- 4) Application is not covered by the ETA-19/0200.

$N_{rec,stat}$, $V_{rec,stat}$ = Recommended load under static and quasi-static action

$N_{rec,eq}$, $V_{rec,eq}$ = Recommended load under seismic action

NPA = no performance assessed

Recommended loads for a working life of 50 years				Ø8	Ø10	Ø12	Ø14	Ø16	Ø20	Ø24	Ø25	Ø28	Ø32	Ø36 ⁴⁾	Ø40 ⁴⁾
• Property class BSt 500 • Concrete - C20/25 • Diamond drilling (DD) • dry, wet concrete															
Recommended tension load	40°C / 24°C ¹⁾ $\psi_{sus}^0 = 0,77$	uncracked	$N_{rec,stat}$ [kN]	13,4	17,5	25,7	28,9	32,7	51,9	68,8	71,3	92,6	103,9	127,8	144,6
	72°C / 50°C ¹⁾ $\psi_{sus}^0 = 0,72$	uncracked	$N_{rec,stat}$ [kN]	10,5	14,8	19,7	24,1	29,9	48,3	68,8	71,3	92,6	103,9	NPA	
Recommended shear load without lever arm ^{2) 3)}		uncracked	$V_{rec,stat}$ [kN]	6,7	10,5	14,8	18,0	20,8	34,1	46,4	48,4	63,8	73,0	106,1	121,3
Embedment depth			h_{ef} [mm]	80	90	110	115	125	170	205	210	250	270	350	380
Edge distance			$c \geq$ [mm]	120	135	165	173	188	255	308	315	375	405	525	570
Axial distance			$s \geq$ [mm]	240	270	330	345	375	510	615	630	750	810	1050	1140

1) Short term temperature/ Long term temperature.

2) Shear loads are valid for all specified temperature ranges.

3) In case of seismic action, the annular gap between the anchor rod and the through hole of the attachment must be filled with mortar, otherwise $\alpha_{gap} = 0,5$ acc. to ETA-19/0200 must be taken into account.

4) Application is not covered by the ETA-19/0200.

$N_{rec,stat}$ $V_{rec,stat}$ = Recommended load under static and quasi-static action

$N_{rec,eq}$ $V_{rec,eq}$ = Recommended load under seismic action

Fire resistance

The present recommended loads of the fire resistance is assessed with respect to its fire resistance properties as anchor applications in walls and ceilings. The assessment is based on the results of the Test Report EBB 170019_1, tests performed according to the requirements of DIN EN 1363-1:2012 and Technical Report 020.

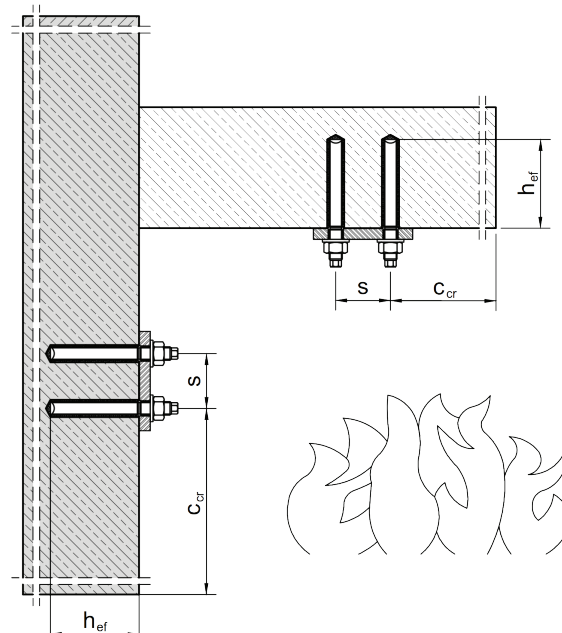

The recommended tension and shear loads under fire exposure of the following table are only valid if the following conditions are met:

- Concrete class min. C20/25
- $c \geq 2,0 \times h_{ef}$
- $s \geq 4,0 \times h_{ef}$
- Threaded rod zinc plated: Property class min. 5.8 (EN 1993-1-8:2005+AC:2009)
- Threaded rod made of stainless steel and high corrosion resistance steel: Property class min. 70 (EN ISO 3506-1:2009)

The recommended loads have been calculated using the partial safety factor for resistances under fire exposure of $\gamma_{M,fi} = 1.0$ and with a partial safety factor for actions of $\gamma_F = 1.0$.

Embedment depth h_{ef} [mm]	Dia-meter [mm]	Recommended load $N_{rec,fi(t)}$ as function of fire resistance time in minutes							
		R30		R60		R90		R120	
		uncracked	cracked	uncracked	cracked	uncracked	cracked	uncracked	cracked
		[kN]		[kN]		[kN]		[kN]	
80	M8	1,1	1,1	0,9	0,9	0,4	0,3	0,0	0,0
85		1,1	1,1	0,9	0,9	0,7	0,6	0,0	0,0
90		1,1	1,1	0,9	0,9	0,7	0,7	0,3	0,2
95		1,1	1,1	0,9	0,9	0,7	0,7	0,5	0,4
≥ 100		1,1	1,1	0,9	0,9	0,7	0,7	0,5	0,5
90	M10	1,7	1,7	1,4	1,4	0,9	0,7	0,0	0,0
95		1,7	1,7	1,4	1,4	1,0	0,9	0,2	0,2
100		1,7	1,7	1,4	1,4	1,0	1,0	0,6	0,5
105		1,7	1,7	1,4	1,4	1,0	1,0	0,8	0,8
≥ 110		1,7	1,7	1,4	1,4	1,0	1,0	0,8	0,8

Steel failure is decisive for the values in the grey cells.

Intermediate values can be interpolated linearly. Extrapolation is not permitted.

Embedment depth h_{ef} [mm]	Dia- meter [mm]	Recommended load $N_{rec,fi(t)}$ as function of fire resistance time in minutes							
		R30		R60		R90		R120	
		uncracked	cracked	uncracked	cracked	uncracked	cracked	uncracked	cracked
		[kN]		[kN]		[kN]		[kN]	
100	M12	3,0	3,0	2,3	2,2	1,5	1,1	0,1	0,1
105		3,0	3,0	2,3	2,3	1,6	1,4	0,7	0,5
110		3,0	3,0	2,3	2,3	1,6	1,6	1,2	0,9
115		3,0	3,0	2,3	2,3	1,6	1,6	1,2	1,2
≥ 120		3,0	3,0	2,3	2,3	1,6	1,6	1,2	1,2
110	M16	5,7	5,7	4,0	3,0	1,9	1,4	0,1	0,1
115		5,7	5,7	4,2	3,4	2,5	1,9	0,7	0,6
120		5,7	5,7	4,2	3,9	3,0	2,3	1,4	1,1
125		5,7	5,7	4,2	4,2	3,0	2,8	2,1	1,5
130		5,7	5,7	4,2	4,2	3,0	3,0	2,2	2,0
135		5,7	5,7	4,2	4,2	3,0	3,0	2,2	2,2
≥ 140		5,7	5,7	4,2	4,2	3,0	3,0	2,2	2,2
120	M20	8,8	8,0	5,2	3,9	2,4	1,8	0,1	0,1
125		8,8	8,8	6,0	4,5	3,2	2,4	0,8	0,6
130		8,8	8,8	6,6	5,1	4,0	3,0	1,7	1,3
135		8,8	8,8	6,6	5,6	4,7	3,5	2,6	1,9
140		8,8	8,8	6,6	6,2	4,7	4,1	3,3	2,5
145		8,8	8,8	6,6	6,6	4,7	4,7	3,4	3,1
150		8,8	8,8	6,6	6,6	4,7	4,7	3,4	3,4
≥ 155		8,8	8,8	6,6	6,6	4,7	4,7	3,4	3,4
130	M24	12,71	10,17	6,67	5,00	3,07	2,30	0,10	0,08
135		12,71	11,26	7,58	5,69	4,03	3,03	0,87	0,66
140		12,71	12,40	8,49	6,37	4,97	3,72	2,07	1,56
145		12,71	12,71	9,40	7,05	5,89	4,41	3,10	2,33
150		12,71	12,71	9,53	7,74	6,71	5,10	4,06	3,05
155		12,71	12,71	9,53	8,51	6,71	5,78	4,94	3,74
160		12,71	12,71	9,53	9,39	6,71	6,46	4,94	4,43
165		12,71	12,71	9,53	9,53	6,71	6,71	4,94	4,94
≥ 170		12,71	12,71	9,53	9,53	6,71	6,71	4,94	4,94
135	M27	15,25	11,44	7,40	5,55	3,08	2,31	0,01	0,01
140		16,52	12,63	8,43	6,32	4,20	3,15	0,37	0,28
145		16,52	13,90	9,47	7,10	5,29	3,97	1,74	1,30
150		16,52	15,16	10,49	7,86	6,33	4,75	2,99	2,24
155		16,52	16,52	11,52	8,64	7,38	5,53	4,13	3,10
160		16,52	16,52	12,39	9,42	8,41	6,31	5,21	3,91
165		16,52	16,52	12,39	10,31	8,72	7,07	6,26	4,69
170		16,52	16,52	12,39	11,30	8,72	7,84	6,43	5,47
175		16,52	16,52	12,39	12,37	8,72	8,60	6,43	6,24
180		16,52	16,52	12,39	12,39	8,72	8,72	6,43	6,43
≥ 185	16,52	16,52	12,39	12,39	8,72	8,72	6,43	6,43	

Steel failure is decisive for the values in the grey cells.

Intermediate values can be interpolated linearly. Extrapolation is not permitted.

Embedment depth h_{ef} [mm]	Dia- meter [mm]	Recommended load $N_{rec,fi(t)}$ as function of fire resistance time in minutes							
		R30		R60		R90		R120	
		uncracked	cracked	uncracked	cracked	uncracked	cracked	uncracked	cracked
		[kN]		[kN]		[kN]		[kN]	
140	M30	17,15	12,86	8,19	6,14	3,07	2,30	0,00	0,00
145		18,88	14,16	9,35	7,01	4,38	3,28	0,19	0,14
150		20,2	15,52	10,50	7,87	5,60	4,20	1,24	0,93
155		20,2	16,96	11,65	8,74	6,79	5,09	2,80	2,10
160		20,2	18,43	12,80	9,60	7,96	5,97	4,14	3,10
165		20,2	19,92	13,94	10,45	9,12	6,84	5,38	4,03
170		20,2	20,20	15,12	11,34	10,27	7,70	6,58	4,93
175		20,2	20,20	15,12	12,36	10,66	8,56	7,74	5,81
180		20,2	20,20	15,12	13,49	10,66	9,41	7,85	6,67
185		20,2	20,20	15,12	14,69	10,66	10,27	7,85	7,53
190		20,2	20,20	15,12	15,15	10,66	10,66	7,85	7,85
≥ 195		20,2	20,20	15,12	15,15	10,66	10,66	7,85	7,85

Steel failure is decisive for the values in the grey cells.

Intermediate values can be interpolated linearly. Extrapolation is not permitted.

3. Post-installed rebar

Installation instruction

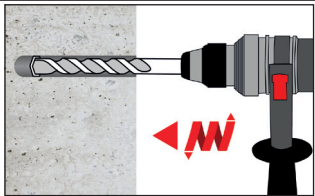
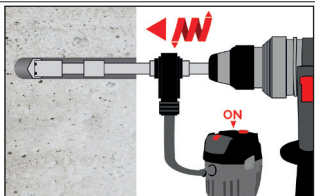
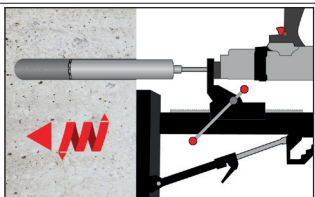
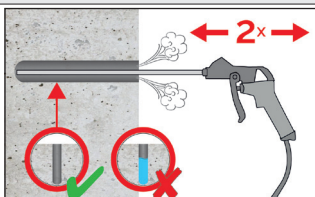
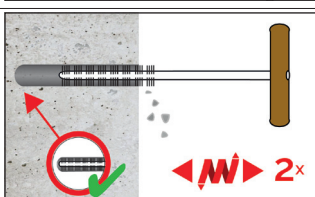
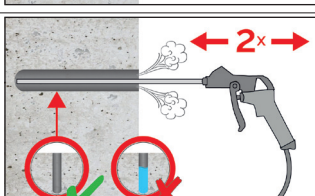
A) Bore hole drilling	
Note: Before drilling, remove carbonated concrete and clean contact areas. in case of aborted drill hole: the drill hole shall be filled with mortar.	
	1a. Hammer (HD) or compressed air drilling (CD). Drill a hole into the base material to the size and embedment depth required by the selected reinforcing bar. Proceed with Step B1.
	1b. Hollow drill bit system (HDB). Drill a hole into the base material to the size and embedment depth required by the selected reinforcing bar. This drill system removes the dust and cleans the bore hole during drilling. Proceed with Step C.
	1c. Diamond drilling (DD). Drill with diamond drill a hole into the base material to the size and embedment depth required by the selected anchor. Proceed with Step B2.
Attention! Standing water in the bore hole must be removed before cleaning.	
B1) Bore hole cleaning	
CAC: Cleaning for all bore hole diameter and bore hole depth with drilling method HD and CD	
	2a. Starting from the bottom or back of the bore hole, blow the hole clean with compressed air (min. 6 bar) (see page 22) a minimum of two times until return air stream is free of noticeable dust. If the bore hole ground is not reached an extension shall be used.
	2b. Check the brush diameter (see page 23). Brush the hole with an appropriate sized wire brush $> d_{b,min}$ (see page 23) a minimum of two times. If the borehole ground is not reached with the brush, a brush extension shall be used.
	2c. Finally blow the hole clean again with compressed air (min. 6 bar) (see page 22) a minimum of two times until return air stream is free of noticeable dust. If the bore hole ground is not reached an extension shall be used.
After cleaning, the bore hole has to be protected against re-contamination in an appropriate way, until dispensing the mortar in the bore hole. If necessary, the cleaning has to be repeated directly before dispensing the mortar. In-flowing water must not contaminate the bore hole again.	

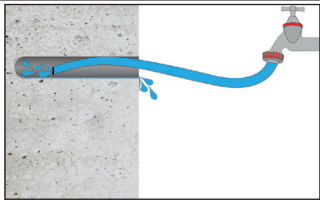
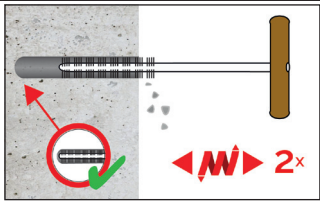
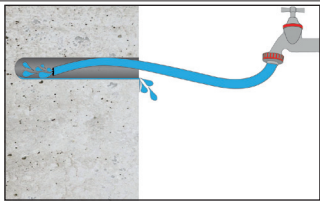
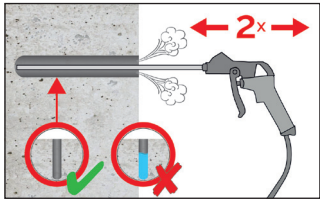
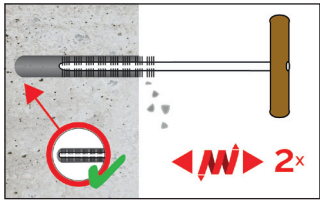
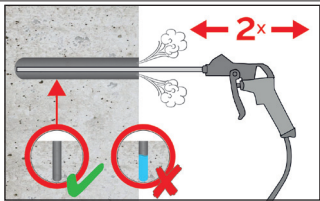
B2) Bore hole cleaning	
SPCAC: Cleaning for all bore hole diameter and bore hole depth with drilling method DD	
	2a. Rinsing with water until clear water comes out.
	2b. Check the brush diameter (see page 23). Brush the hole with an appropriate sized wire brush $> d_{b,min}$ (see page 23) a minimum of two times. If the borehole ground is not reached with the brush, a brush extension shall be used.
	2c. Rinsing again with water until clear water comes out.
Attention! Standing water in the bore hole must be removed before cleaning.	
	2a. Starting from the bottom or back of the bore hole, blow the hole clean with compressed air (min. 6 bar) (see page 22) a minimum of two times until return air stream is free of noticeable dust. If the bore hole ground is not reached an extension shall be used
	2b. Check the brush diameter (see page 23). Brush the hole with an appropriate sized wire brush $> d_{b,min}$ (see page 23) a minimum of two times. If the borehole ground is not reached with the brush, a brush extension shall be used.
	2c. Finally blow the hole clean again with compressed air (min. 6 bar) (see page 22) a minimum of two times until return air stream is free of noticeable dust. If the bore hole ground is not reached an extension shall be used.
After cleaning, the bore hole has to be protected against re-contamination in an appropriate way, until dispensing the mortar in the bore hole. If necessary, the cleaning has to be repeated directly before dispensing the mortar. In-flowing water must not contaminate the bore hole again.	

Cleaning and installation tools

Rec. compressed air tool hand slide valve
(min 6 bar)



Brush RBT and brush extension

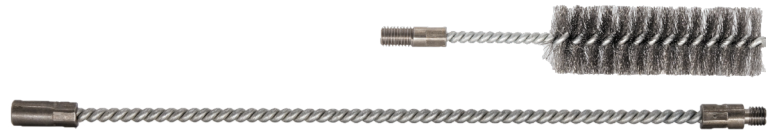

Hand pump (volume 750 ml)



SDS Plus Adapter



HDB - Hollow drill bit



C) Preparation of bar and cartridge

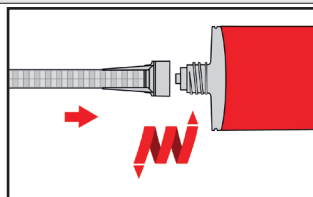

3a. Attach the static mixer tightly onto the cartridge and insert the cartridge into a suitable dispensing tool. For every working interruption longer than the recommended working time (see page 4) as well as for new cartridges, a new static-mixer shall be used.

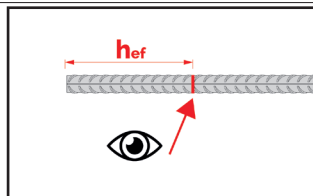

3b. Prior to inserting the reinforcing bar into the filled bore hole, the position of the embedment depth shall be marked (e.g. with tape) on the reinforcing bar and insert bar in empty hole to verify hole and depth l_v (see page 24). The bar should be free of dirt, grease, oil or other foreign material.

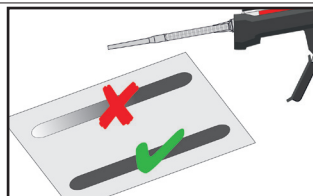

3c. Prior to dispensing into the anchor hole, squeeze out separately the mortar until it shows a consistent grey or red colour, but a minimum of three full strokes and discard non-uniformly mixed adhesive components.

D) Filling the bore hole

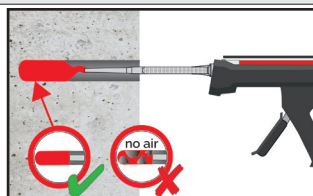

4. Starting from the bottom or back of the cleaned bore hole with adhesive, until the level mark at the mixer extension (see below) is visible at the top of the hole. Slowly withdraw the static mixing nozzle and using a piston plugs during injection of the mortar, helps to avoid creating air pockets.

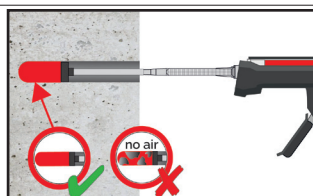

For overhead and horizontal installation and bore holes deeper than 240 mm a piston plug and the appropriate mixer extension must be used.

Observe the gel-/working times given on table page 4.

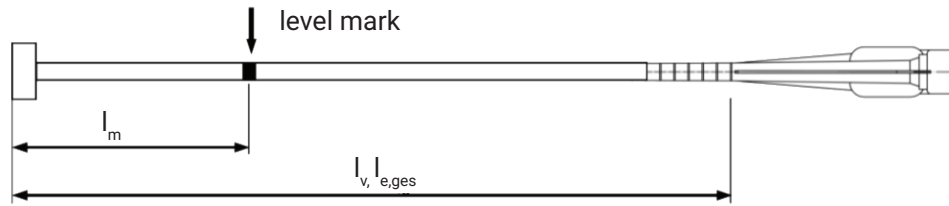

Injection tool must be marked by mortar level mark l_m and anchorage depth l_v resp. $l_{e,ges}$ with tape or marker.

Quick estimation: $l_m = 1/3 * l_v$

Continue injection until mortar level mark l_m becomes visible.

Optimum mortar volume: $l_m = l_v$ rep. $l_{e,ges} * (1,2 * \varnothing^2 / d_0^2 * 0,2)$ [mm]

Brushes, piston plugs, maximum embedment depth and mixer extension, hammer (HD), diamond (DD) and compressed air drilling (CD)

Bar size Ø	Tension anchor Ø	Drill bit-Ø			d_b Brush - Ø		$d_{b,min}$ min. Brush - Ø	Piston plug	Cartridge: 440 ml or 585 ml				Cartridge: 1400 ml			
		HD	DD	CD					Hand or battery tool		Pneumatic tool		Pneumatic tool			
					$l_{v,max}$	Mixer extension			$l_{v,max}$	Mixer extension	$l_{v,max}$	Mixer extension				
[mm]	[mm]	[mm]	[mm]	[mm]	[-]	[mm]	[mm]	[Nr.]	[cm]	[-]	[cm]	[-]	[cm]	[-]		
8	-	10	-	RB10	11,5	10,5	-	250	VL 10/0,75 or VL 16/1,8	-	250	VL 10/0,75 or VL 16/1,8	250	VL 10/0,75 or VL 16/1,8		
	-	12	-	RB12	13,5	12,5	-	700			800		800			
10	-	12	-	RB12	13,5	12,5	-	250		250	250					
	-	14	-	RB14	15,5	14,5	VS14	700		1000	1000					
12	ZA-M12	14	-	RB14	15,5	14,5	VS14	250		250	250					
		16		RB16	17,5	16,5	VS16	700		VL 10/0,75 or VL 16/1,8	1300		1200			
14	-	18	-	RB18	20,0	18,5	VS18				700		1300		1400	
16	ZA-M16	20		RB20	22,0	20,5	VS20	500		-	-		1600		-	-
20	ZA-M20	25	-	RB25	27,0	25,5	VS25						500			
		-	26	RB26	28,0	26,5	VS25									
22	-	28		RB28	30,0	28,5	VS28	500	-	-	-	-	-			
24/25	ZA-M24	32		RB32	34,0	32,5	VS32									
28	-	35		RB35	37,0	35,5	VS35	500	-	-	-	-	-			
32/34	-	40		RB40	43,5	40,5	VS40									
36	-	45		RB45	47,0	45,5	VS45	-	-	-	-	-	-			
40	-	-	52	-	RB52	54,0	52,5							VS52		
		55	-	55	RB55	58,0	55,5	VS55								

Brushes, piston plugs, maximum embedment depth and mixer extension, hollow drill bit system (HDB)

Bar size Ø	Tension anchor Ø	Drill bit-Ø	d _b Brush - Ø		d _{b,min} min. Brush - Ø	Piston plug	Cartridge: 440 ml or 585 ml				Cartridge: 1400 ml				
							Hand or battery tool		Pneumatic tool		Pneumatic tool				
		HDB					l _{v,max}	Mixer extension	l _{v,max}	Mixer extension	l _{v,max}	Mixer extension			
[mm]	[mm]	[mm]	[-]	[mm]	[mm]	[Nr.]	[cm]	[-]	[cm]	[-]	[cm]	[-]			
8	-	10	No cleaning required			-	250	VL 10/0,75 or VL 16/1,8	1000	VL 10/0,75 or VL 16/1,8	1000	VL 10/0,75 or VL 16/1,8			
	-	12				-	700						250	800	250
10	-	12				-	250						250	250	
	-	14				-	700						1000	1000	
12	ZA-M12	14				VS14	250						250	250	
		16				VS16	700						1000	1000	
14	-	18				VS18									
16	ZA-M16	20				VS20									
20	ZA-M20	25				VS25	500						1000	1000	
22	-	28				VS28									
24/25	ZA-M24	32				VS32									
28	-	35				VS35									
32/34	-	40				VS40									

E) Inserting the rebar

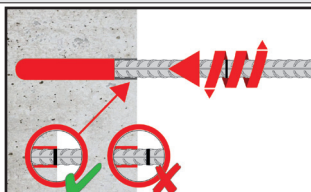

5a. Push the reinforcing bar into the anchor hole while turning slightly to ensure positive distribution of the adhesive until the embedment depth is reached.

The bar should be free of dirt, grease, oil or other foreign material.

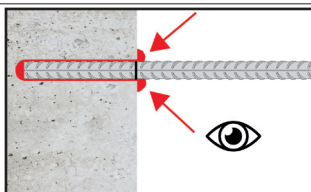

5b. Be sure that the bar is inserted in the bore hole until the embedment mark is at the concrete surface and that excess mortar is visible at the top of the hole. If these requirements are not maintained, the application has to be renewed. For overhead application the anchor rod shall be fixed (e.g. wedges).

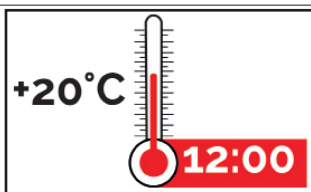

5c. Observe gelling time t_{gel}. Attend that the gelling time can vary according to the base material temperature (see page 4). It is not allowed to move the bar after gelling time t_{gel} has elapsed. Allow the adhesive to cure to the specified time prior to applying any load. Do not move or load the bar until it is fully cured (attend table on page 4). After full curing time t_{cure} has elapsed, the add-on part can be installed.

Design anchorage and lap length

The calculation of the design anchoring lengths of reinforcing bars, if used as end anchoring or as overlapping joint, has to consider the details and provisions of the approval ETA-19/0200 and the EN 1992-1-1:2004+AC:2010.

The design load with corresponding failure mode („pull-out failure“ or „steel failure“) were determined for selected rebar diameters and anchorage lengths. The results for end anchoring and overlapping joints are given in the tables below.

The calculations are based on following assumptions:

- Rebar BSt 500 S, $f_{yk} = 500 \text{ N/mm}^2$, Material safety factor of $\gamma_s = 1,15$
- Concrete class C20/25 and „good bond conditions“ acc. EN 1992-1-1:2004+AC:2010 considered. Rebar diameters $\leq d = 32 \text{ mm}$.
- The bond properties of the bars is considered by the coefficients:
 - $\alpha_1 = 1,0$; is for the effect of the form of the bars assuming adequate cover; 1,0 for straight rebars
 - $\alpha_2 = 1,0$; is for the effect of concrete minimum cover; has to be checked
 - $\alpha_3 = 1,0$; is for the effect of confinement by transverse reinforcement; 1,0 for no transverse reinforcement
 - $\alpha_4 = 1,0$; is for the influence of one or more welded transverse bars; 1,0 for no welded transverse reinforcement
 - $\alpha_5 = 1,0$; is for the effect of the pressure transverse; 1,0 if no transverse pressure is assumed
 - $\alpha_6 = 1,5$; is for the percentage of lapped bars relative to the total cross-section area, 1,5 due to the given situation on the construction side

All drilling methods (hammer drilling (HD), compressed air drilling (CD), Hollow drill bit (HDB), Diamond drilling (DD)) are considered by the amplification factor of $\alpha_{ib} = 1,0$

End anchoring of slabs or beams (e.g. designed as simply supported)

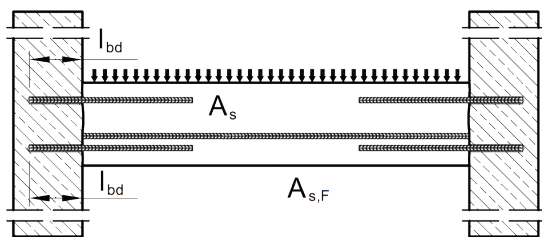

Overlapping joint for rebar connections of slabs and beams

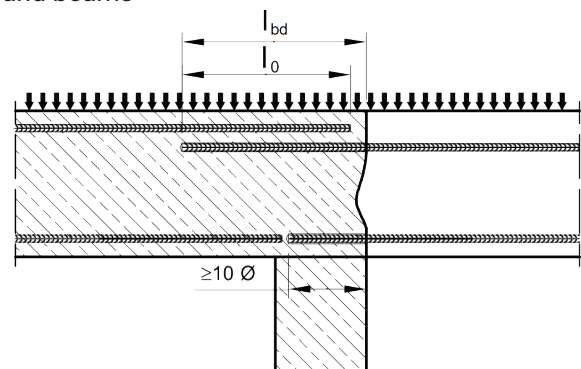

Rebar Ø8 - Ø40			End anchoring			Overlapping joint		
<ul style="list-style-type: none"> Concrete class C20/25 Rebar BSt 500 S; $f_{yk} = 500 \text{ N/mm}^2$ Hammer- (HD), hollow- (HDB), compressed air (CD) or diamond drilling (DD) 			$\alpha_1 = \alpha_2 = \alpha_3 = \alpha_4 = \alpha_5 = 1,0$			$\alpha_1 = \alpha_2 = \alpha_3 = \alpha_4 = \alpha_5 = 1,0$		
			$\alpha_{lb} = 1,0$			$\alpha_6 = 1,5$		
						$\alpha_{lb} = 1,0$		
d	$N_{Rd,s}$	$l_{v,max}^{2)}$	l_{bd}	N_{Rd}	Volume Mortar	l_0	N_{Rd}	Volume Mortar ¹⁾
[mm]	[kN]	[mm]	[mm]	[kN]	[ml]	[mm]	[kN]	[ml]
Ø8	21,9	1000 (1000)	113 ³⁾	6,6	9	200 ⁴⁾	7,7	15
			200	11,6	15	320	12,3	24
			290	16,8	22	440	17,0	33
			378	21,9	29	567	21,9	43
Ø10	34,1	1000 (1000)	142 ³⁾	10,2	13	213 ⁴⁾	10,2	19
			250	18,1	23	380	18,3	34
			360	26,0	33	550	26,5	50
			473	34,1	43	709	34,1	64
Ø12	49,2	1200 (1000)	170 ³⁾	14,8	18	255 ⁴⁾	14,8	27
			300	26,0	32	450	26,0	48
			430	37,3	45	650	37,6	69
			567	49,2	60	851	49,2	90
Ø14	66,9	1400 (1000)	198 ³⁾	20,1	24	298 ⁴⁾	20,1	36
			350	35,4	42	530	35,7	64
			500	50,6	60	760	51,3	92
			662	66,9	80	992	66,9	120
Ø16	87,4	1600 (1000)	227 ³⁾	26,2	31	340 ⁴⁾	26,2	46
			400	46,2	54	600	46,2	81
			580	67,1	79	860	66,3	117
			756	87,4	103	1134	87,4	154
Ø20	136,6	2000 (1000)	284 ³⁾	41,0	60	425 ⁴⁾	41,0	90
			500	72,3	106	760	73,2	161
			720	104,0	153	1090	105,0	231
			945	136,6	200	1418	136,6	301
Ø22	165,3	2000 (1000)	312 ³⁾	49,6	22	468 ⁴⁾	49,6	132
			550	87,4	39	830	88,0	235
			790	125,6	56	1190	126,1	336
			1040	165,3	73	1560	165,3	441
Ø24	196,7	2000 (1000)	340 ³⁾	59,0	144	510 ⁴⁾	59,0	216
			600	104,0	253	910	105,2	384
			860	149,1	363	1310	151,4	553
			1134	196,7	479	1701	196,7	718
Ø25	213,4	2000 (1000)	354 ³⁾	64,0	133	532 ⁴⁾	64,0	200
			630	113,8	237	950	114,4	357
			910	164,4	342	1360	163,8	511
			1181	213,4	444	1772	213,4	666

¹⁾ Mortar volume of the overlap joint. The mortar volume of the concrete cover c_1 , at the face of the existing reinforcing steel, was not taken into account.

²⁾ $l_{v,max}$ see ETA-19/0200. Values in brackets are valid for hollow drill bits, only.

³⁾ = $l_{b,min}$ (acc. to EN 1992-1-1:2004)

⁴⁾ = $l_{0,min}$ (acc. to EN 1992-1-1:2004)

Rebar Ø8 - Ø40			End anchoring			Overlapping joint		
<ul style="list-style-type: none"> Concrete class C20/25 Rebar BSt 500 S; $f_{yk} = 500 \text{ N/mm}^2$ Hammer- (HD), hollow- (HDB), compressed air (CD) or diamond drilling (DD) 			$\alpha_1 = \alpha_2 = \alpha_3 = \alpha_4 = \alpha_5 = 1,0$			$\alpha_1 = \alpha_2 = \alpha_3 = \alpha_4 = \alpha_5 = 1,0$		
			$\alpha_{lb} = 1,0$			$\alpha_6 = 1,5$		
						$\alpha_{lb} = 1,0$		
d	$N_{Rd,s}$	$l_{v,max}^{2)}$	l_{bd}	N_{Rd}	Volume Mortar	l_0	N_{Rd}	Volume Mortar ¹⁾
[mm]	[kN]	[mm]	[mm]	[kN]	[ml]	[mm]	[kN]	[ml]
Ø28	267,7	2000 (1000)	397 ³⁾	80,3	165	595 ⁴⁾	80,3	247
			710	143,6	295	1060	143,0	441
			1020	206,4	424	1520	205,0	632
			1323	267,7	550	1985	267,7	825
Ø32	349,7	2000 (1000)	454 ³⁾	104,9	246	681 ⁴⁾	104,9	369
			810	187,3	440	1120	172,6	608
			1160	268,2	630	1560	240,5	847
			1512	349,7	821	2000	308,3	1086
Ø34	394,7	2000 (-)	482 ³⁾	118,4	202	723 ⁴⁾	118,4	303
			860	211,3	360	1150	188,3	481
			1230	302,2	515	1580	258,8	661
			1607	394,7	672	2000	327,6	837
Ø36	442,6	2000 (-)	510 ³⁾	127,0	351	766 ⁴⁾	127,0	526
			930	231,4	639	1180	195,7	811
			1350	335,9	928	1590	263,7	1092
			1779	442,6	1222	2000	331,8	1374
Ø40	546,4	2000 (-)	567 ³⁾	149,7	762	851 ⁴⁾	149,7	1142
			1040	274,4	1397	1230	216,4	1652
			1520	401,1	2041	1610	283,2	2162
			2000	527,8	2686	2000	351,9	2686

¹⁾ Mortar volume of the overlap joint. The mortar volume of the concrete cover c_1 , at the face of the existing reinforcing steel, was not taken into account.

²⁾ $l_{v,max}$ see ETA-19/0200. Values in brackets are valid for hollow drill bits, only.

³⁾ = $l_{b,min}$ (acc. to EN 1992-1-1:2004)

⁴⁾ = $l_{0,min}$ (acc. to EN 1992-1-1:2004)

The specified design load N_{Rd} (End anchoring, Overlapping joints) can be converted to further concrete classes, while maintaining the previously accepted boundary conditions and anchorage lengths l_{bd} or lap length l_0 , with the approach as follows:

$$N_{Rd,con} = \min(N_{Rd,s}; N_{Rd} * f_{bd,con} - \text{Factor}) \text{ [kN]}$$

The adaptation of the anchorage length l_{bd} or overlap length l_0 to different concrete classes can be done for the given design load N_{Rd} from the previous tables using the following equations:

$$l_{bd,con} = \max (l_{b,min}; l_{bd} / f_{bd,con} - \text{Factor}) \text{ [mm]}$$

$$l_{0,con} = \max (l_{0,min}; l_0 / f_{bd,con} - \text{Factor}) \text{ [mm]}$$

with:

$l_{bd,con}$ = anchorage length, converted to concrete class [mm]

$l_{0,con}$ = lap length, converted to concrete class [mm]

$l_{bd}; l_{b,min}$ = (minimum) anchorage length acc. to EN 1992-1-1:2004, see previous table [mm]

$l_0; l_{0,min}$ = (minimum) lap length acc. to EN 1992-1-1:2004, see previous table [mm]

The conversion factor $f_{bd,con}$ can be taken from the table below:

Rebar Ø	Ø8 to Ø32 mm ZA-M12 to ZA-M24		Ø 34 mm		Ø 36 mm		Ø 40 mm	
	f_{bd}	$f_{bd,con}$ - Factor	f_{bd}	$f_{bd,con}$ - Factor	f_{bd}	$f_{bd,con}$ - Factor	f_{bd}	$f_{bd,con}$ - Factor
[-]	[N/mm ²]	[-]	[N/mm ²]	[-]	[N/mm ²]	[-]	[N/mm ²]	[-]
C12/15	1,6	0,70	1,6	0,70	1,5	0,68	1,5	0,71
C16/20	2,0	0,87	2,0	0,87	1,9	0,86	1,8	0,86
C20/25	2,3	1,00	2,3	1,00	2,2	1,00	2,1	1,00
C25/30	2,7	1,17	2,6	1,13	2,6	1,18	2,5	1,19
C30/37	3,0	1,30	2,9	1,26	2,9	1,32	2,8	1,33
C35/45	3,4	1,48	3,3	1,43	3,3	1,50	3,1	1,48
C40/50	3,7	1,61	3,6	1,57	3,6	1,64	3,4	1,62
C45/55	4,0	1,74	3,9	1,70	3,8	1,73	3,7	1,76
C50/60	4,3	1,87	4,2	1,83	4,1	1,86	4,0	1,90

Fire resistance - Overlapping joints

The present tables are supplying the mean reduction factor $\bar{k}_{\theta(x)}$, needed for determining the design bond strength $f_{bd,fi}$ of post-installed rebar connections under fire exposure in a fire-resistance grating.

The specified mean reduction factor $\bar{k}_{\theta(x)}$ is valid for slab to slab connections (overlapping joints), where the lower surface is exposed perpendicular to fire (one side), the temperature is uniform. Therefore the bond resistance is uniform along the bond also and depends on the concrete cover and the duration of the fire.

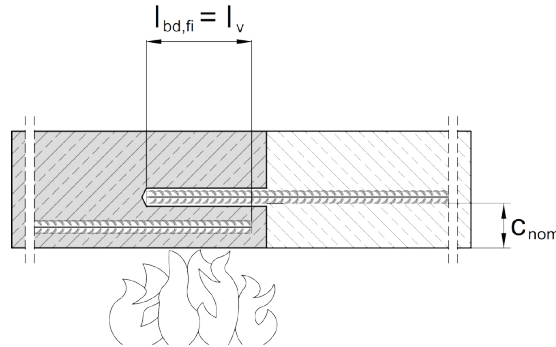

The heat development of structural members is calculated by a fire model, based on the standard uniform-temperature-time-curve (UTTC) acc. to ISO 834-1 and tries to simulate a real fire. Below the calculated heat distribution of a slab after a temperature impact of 14400 sec. (240min) for the fire-resistance grade R240.

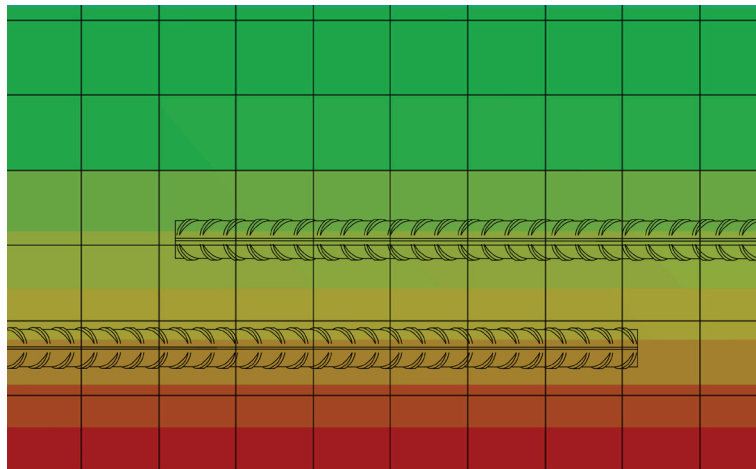

The effect of heat on the bond strength of the mortar was determined by tests and is expressed by the reduction factor $k_{b,fi}(\theta)$ given in the ETA-19/0200.

The calculation of the required design lap length l_0 shall be carried out in accordance with EN 1992-1-1:2004+AC:2010, section 8.7.3 and the provisions of the ETA-19/0200 shall be met. The design value of the bond strength $f_{bd,fi}$ under fire exposure has to be calculated by the following equation:

$$f_{bd,fi} = \bar{k}_{\theta(x)} * f_{bd,PIR} * \gamma_c / \gamma_{M,fi} * f_{bd,fi,con} \leq f_{bd,PIR}$$

with:

- $f_{bd,fi}$ = Design value of the bond strength under fire exposure in N/mm²
- $\bar{k}_{\theta(x)}$ = Mean reduction factor under fire exposure as a function of the temperature profile, given in the tables below
- $f_{bd,PIR}$ = Design value of the bond strength in cold condition acc. ETA-19/0200, tab. C2 depending on concrete class, rebar diameter, drilling method and bonding range acc. EN 1992-1-1 in N/mm²
- γ_c = Partial safety factor of concrete acc. EN 1992-1-1; 1,5 in absence of national regulation
- $\gamma_{M,fi}$ = Partial safety factor of fire exposure acc. EN 1992-1-2; 1,0 in absence of national regulation
- $f_{bd,fi,con}$ = Conversion factor taking into account the influence of the concrete class

The mean reduction factor $\bar{k}_{\theta(x)}$ for slab to slab connections with rebar Ø8 - Ø32 mm and fire at 30, 60, 90, 120, 180 or 240 min is given for a concrete cover c_{nom} in the present table and valid for good bond conditions only:

Overlapping joint						
Rebar Ø8 - Ø40 mm	Mean reduction factor under fire exposure $\bar{k}_{\theta(x)}$ ²⁾					
	Fire-resistance grading					
c_{nom} ¹⁾ [mm]	R30	R60	R90	R120	R180	R240
	[-]	[-]	[-]	[-]	[-]	[-]
10	0,00	0,00	0,00	0,00	0,00	0,00
15						
20						
25						
30	0,07	0,07	0,06	0,06	0,00	0,00
35	0,09					
40	0,12					
45	0,16					
50	0,21	0,07	0,07	0,06	0,00	0,00
55	0,28	0,08				
60	0,36	0,10				
65	0,47	0,13				
70	0,58	0,15	0,08	0,06	0,00	0,00
75	0,72	0,18	0,10			
80	0,86	0,22	0,11			
85	1,00	0,26	0,13			
90	1,00	0,31	0,15	0,10		

Overlapping joint						
Rebar Ø8 - Ø40 mm	Mean reduction factor under fire exposure $\bar{k}_{\theta(x)}$ ²⁾					
	Fire-resistance grading					
c_{nom} ¹⁾	R30	R60	R90	R120	R180	R240
[mm]	[-]	[-]	[-]	[-]	[-]	[-]
95	1,00	0,36	0,17	0,11	0,06	0,00
100	1,00	0,42	0,20	0,13	0,07	
105	1,00	0,49	0,23	0,14	0,08	
110	1,00	0,57	0,27	0,16	0,09	0,06
115	1,00	0,65	0,31	0,18	0,10	0,07
120	1,00	0,76	0,35	0,21	0,11	0,07
125	1,00	0,86	0,40	0,24	0,12	0,08
130	1,00	0,97	0,46	0,27	0,14	0,09
135	1,00	1,00	0,52	0,31	0,15	0,10
140	1,00	1,00	0,58	0,34	0,17	0,11
145	1,00	1,00	0,66	0,39	0,19	0,12
150	1,00	1,00	0,74	0,44	0,21	0,13
155	1,00	1,00	0,83	0,49	0,23	0,14
160	1,00	1,00	0,94	0,54	0,26	0,16
165	1,00	1,00	1,00	0,61	0,29	0,17
170	1,00	1,00	1,00	0,68	0,32	0,19
175	1,00	1,00	1,00	0,74	0,35	0,21
180	1,00	1,00	1,00	0,81	0,38	0,23

¹⁾ c_{nom} = concrete cover

²⁾ $\bar{k}_{\theta(x)}$ = Mean reduction factor over the embedment depth of the rebar as a function of the temperature profile I

Intermediate values of $\bar{k}_{\theta(x)}$ may be interpolated linearly. Extrapolation is not permitted.

The bond strength $f_{bd,PIR}$ depends on the concrete class and rebar diameter as well as the corresponding conversion factor $f_{bd,fi,con}$ and can be found in the following table:

Concrete class	Ø-Rebar	$f_{bd,PIR}$ (all drilling methods)	$f_{bd,fi,con}$ - Factor
[-]	[mm]	[N/mm ²]	[-]
C12/15	Ø8 - Ø34	1,6	1,44
	Ø36, Ø40	1,5	1,53
C16/20	Ø8 - Ø34	2,0	1,15
	Ø36	1,9	1,21
	Ø40	1,8	1,28
C20/25	Ø8 - Ø34	2,3	1,00
	Ø36	2,2	1,05
	Ø40	2,1	1,10
C25/30	Ø8 - Ø32	2,7	0,85
	Ø34, Ø36	2,6	0,88
	Ø40	2,5	0,92
C30/37	Ø8 - Ø32	3,0	0,77
	Ø34, Ø36	2,9	0,79
	Ø40	2,8	0,82
C35/45	Ø8 - Ø32	3,4	0,68
	Ø34, Ø36	3,3	0,70
	Ø40	3,1	0,74
C40/50	Ø8 - Ø32	3,7	0,62
	Ø34, Ø36	3,6	0,64
	Ø40	3,4	0,68
C45/55	Ø8 - Ø32	4,0	0,58
	Ø34	3,9	0,59
	Ø36	3,8	0,61
	Ø40	3,7	0,62
C50/60	Ø8 - Ø32	4,3	0,53
	Ø34	4,2	0,55
	Ø36	4,1	0,56
	Ø40	4,0	0,58

The given values does not deal with the mechanical design at ambient temperature, these shall be done in addition and related to ETA-19/0200.

Post-installed rebar connections shall be designed in ambient temperature conditions before being designed in fire conditions.

The partial safety factor for actions can be assumed to be $\gamma_F = 1,0$ for determining recommended loads.

Fire resistance - Beam/wall or column/slab

The present table is supplying the mean reduction factor $\bar{k}_{\theta(x)}$, needed for determining the design bond strength $f_{bd,fi}$ of post-installed rebar connections under fire exposure in a fire-resistance rating.

The mean reduction factor $\bar{k}_{\theta(x)}$ is valid for beam to wall or column to slab connections, where the rebar is bonded inside the wall or slab, there is a temperature gradient in the thickness of the wall respectively slab if the beam (three sides) or column is exposed to fire (four sides).

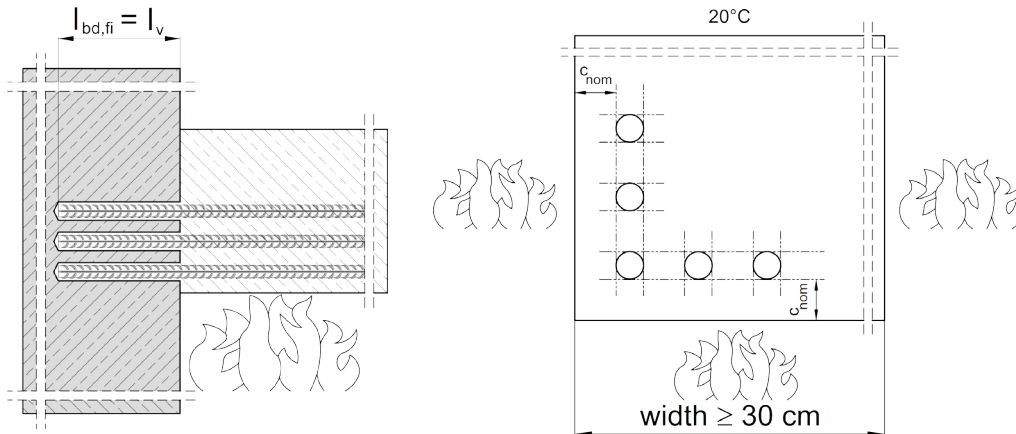

The temperature along the bonding interface is not uniform and depends on the fire duration, the anchoring length and the concrete cover of the rebar inside the beam (which acts as a protection against thermal exposure). Therefore, the temperature profiles along the bond are determined for each fire duration, for each bonded length and for the concrete covers inside the beam of $c_{nom} = 10, 20, 30$ and 40 mm.

The given mean reduction factor $\bar{k}_{\theta(x)}$ is a mean value as a function of the temperature profile along the bonding length.

The calculated model of the fire is based on the standard uniform-temperature-time-curve (UTTC) acc. to ISO 834-1 and tries to simulate the heat development of structural members at a real fire. Below the calculated heat distribution of a beam / column and wall / slab after a temperature impact of 14400 sec. (240min) for the fire-resistance grade R240.

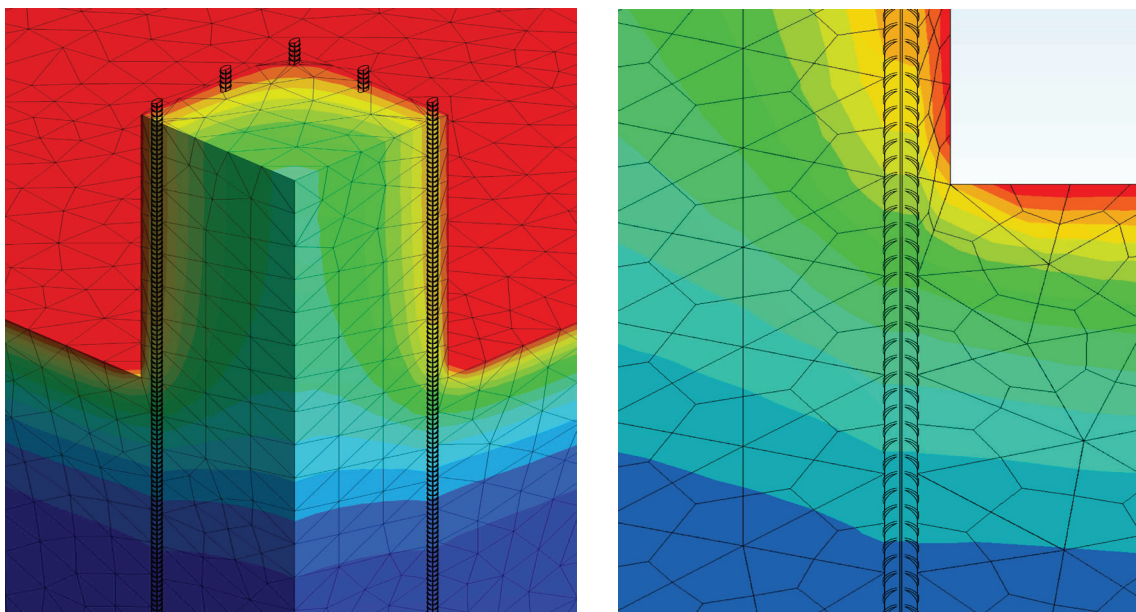

The fire model determines the heat distribution for rebars at the component corner (2 sides flamed) and at the component edge (1 side flamed).

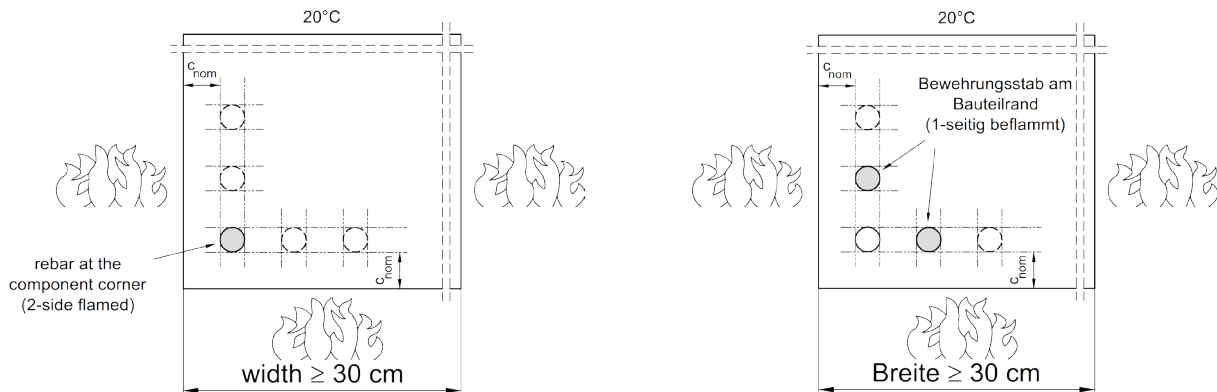

The effect of heat on the bond strength of the mortar was determined by tests and is expressed by the reduction factor $k_{b,fi}(\theta)$ given in the ETA-19/0200.

The calculation of the required design lap length l_0 shall be carried out in accordance with EN 1992-1-1:2004+AC:2010, section 8.7.3 and the provisions of the ETA-19/0200 shall be met.

The design value of the bond strength $f_{bd,fi}$ under fire exposure has to be calculated by the following equation:

$$f_{bd,fi} = \bar{k}_{\theta(x)} * f_{bd,PIR} * \gamma_c / \gamma_{M,fi} * f_{bd,fi,con} \leq f_{bd,PIR}$$

with:

- $f_{bd,fi}$ = Design value of the bond strength under fire exposure in N/mm²
- $\bar{k}_{\theta(x)}$ = Mean reduction factor under fire exposure as a function of the temperature profile, given in the tables below
- $f_{bd,PIR}$ = Design value of the bond strength in cold condition acc. ETA-19/0200, tab. C2 depending on concrete class, rebar diameter, drilling method and bonding range acc. EN 1992-1-1 in N/mm²
- γ_c = Partial safety factor of concrete acc. EN 1992-1-1; 1,5 in absence of national regulation
- $\gamma_{M,fi}$ = Partial safety factor of fire exposure acc. EN 1992-1-2; 1,0 in absence of national regulation
- $f_{bd,fi,con}$ = Conversion factor taking into account the influence of the concrete class

The mean reduction factor $\bar{k}_{\theta(x)}$ for e.g. beam on wall or column on slab applications for concrete covers of $c_{nom} = 10, 20, 30$ and 40 mm with the corresponding diameter of the rebar and fire-resistance grading at 30, 60, 90, 120, 180 or 240 min is given for a rebar at the edge (1 side flamed) or at the corner (2 sides flamed) in the following tables and valid for good bond conditions:

Endanchoring - Mean reduction factor under fire exposure $\bar{k}_{\theta(x)}$ ³⁾												
$c_{nom} = 10$ mm ¹⁾	Rebar at the edge (1 side flamed)						Rebar at the corner (2 sides flamed)					
Rebar Ø8 - Ø20	Fire-resistance grading						Fire-resistance grading					
l_v ²⁾	R30	R60	R90	R120	R180	R240	R30	R60	R90	R120	R180	R240
[mm]	[-]	[-]	[-]	[-]	[-]	[-]	[-]	[-]	[-]	[-]	[-]	[-]
80	0,29	0,10	0,07	0,05	0,03	0,03	0,16	0,06	0,04	0,03	0,02	0,02
90	0,36	0,12	0,08	0,06	0,04	0,03	0,21	0,08	0,05	0,03	0,02	0,02
100	0,42	0,15	0,09	0,07	0,04	0,03	0,27	0,10	0,06	0,04	0,03	0,02
110	0,48	0,18	0,11	0,08	0,05	0,03	0,34	0,12	0,07	0,05	0,03	0,03
120	0,52	0,23	0,13	0,09	0,05	0,04	0,39	0,14	0,08	0,06	0,04	0,03
130	0,56	0,28	0,15	0,10	0,06	0,04	0,44	0,17	0,10	0,07	0,04	0,03
140	0,59	0,33	0,19	0,12	0,07	0,05	0,48	0,21	0,13	0,08	0,05	0,04
150	0,62	0,38	0,22	0,14	0,08	0,05	0,51	0,25	0,16	0,10	0,06	0,04
160	0,64	0,41	0,27	0,17	0,09	0,06	0,54	0,30	0,19	0,12	0,07	0,05
170	0,66	0,45	0,31	0,20	0,11	0,07	0,57	0,34	0,24	0,15	0,08	0,06
180	0,68	0,48	0,35	0,24	0,12	0,08	0,60	0,38	0,28	0,18	0,09	0,06
190	0,70	0,51	0,38	0,28	0,14	0,09	0,62	0,41	0,32	0,21	0,11	0,07
200	0,71	0,53	0,42	0,31	0,16	0,10	0,64	0,44	0,35	0,25	0,13	0,08
210	0,73	0,55	0,44	0,34	0,18	0,11	0,65	0,47	0,38	0,29	0,15	0,09
220	0,74	0,57	0,47	0,37	0,21	0,13	0,67	0,49	0,41	0,32	0,17	0,11
230	0,75	0,59	0,49	0,40	0,24	0,14	0,68	0,51	0,44	0,35	0,20	0,12
240	0,76	0,61	0,51	0,43	0,27	0,16	0,70	0,53	0,46	0,38	0,23	0,14
250	0,77	0,63	0,53	0,45	0,30	0,18	0,71	0,55	0,48	0,40	0,26	0,16
260	0,78	0,64	0,55	0,47	0,33	0,21	0,72	0,57	0,50	0,43	0,29	0,18
270	0,79	0,65	0,57	0,49	0,35	0,23	0,73	0,58	0,52	0,45	0,32	0,20
280	0,79	0,67	0,58	0,51	0,38	0,26	0,74	0,60	0,54	0,47	0,34	0,23
290	0,80	0,68	0,60	0,53	0,40	0,28	0,75	0,61	0,55	0,48	0,36	0,26
300	0,81	0,69	0,61	0,54	0,42	0,31	0,76	0,63	0,57	0,50	0,39	0,28
310	0,81	0,70	0,62	0,56	0,44	0,33	0,77	0,64	0,58	0,52	0,41	0,30
320	0,82	0,71	0,63	0,57	0,45	0,35	0,77	0,65	0,60	0,53	0,42	0,33
350	0,84	0,73	0,67	0,61	0,50	0,41	0,79	0,68	0,63	0,57	0,47	0,38
400	0,86	0,77	0,71	0,66	0,56	0,48	0,82	0,72	0,68	0,63	0,54	0,46
450	0,87	0,79	0,74	0,69	0,61	0,54	0,84	0,75	0,71	0,67	0,59	0,52
500	0,88	0,81	0,77	0,72	0,65	0,58	0,85	0,78	0,74	0,70	0,63	0,57
550	0,90	0,83	0,79	0,75	0,68	0,62	0,87	0,80	0,76	0,73	0,66	0,61
600	0,90	0,84	0,81	0,77	0,71	0,65	0,88	0,81	0,78	0,75	0,69	0,64
700	0,92	0,87	0,83	0,80	0,75	0,70	0,90	0,84	0,82	0,79	0,74	0,69
800	0,93	0,88	0,85	0,83	0,78	0,74	0,91	0,86	0,84	0,81	0,77	0,73
900	0,94	0,90	0,87	0,85	0,81	0,77	0,92	0,88	0,86	0,83	0,80	0,76
1000	0,94	0,91	0,88	0,86	0,83	0,79	0,93	0,89	0,87	0,85	0,82	0,78

¹⁾ c_{nom} = concrete cover

²⁾ l_v = embedment length of the bar in the concrete

³⁾ $\bar{k}_{\theta(x)}$ = Mean reduction factor over the embedment depth of the rebar as a function of the temperature profile

Intermediate values of $\bar{k}_{\theta(x)}$ may be interpolated linearly. Extrapolation is not permitted.

Endanchoring - Mean reduction factor under fire exposure $\bar{k}_{\theta(x)}$ ³⁾												
$c_{nom} = 20$ mm ¹⁾	Rebar at the edge (1 side flamed)						Rebar at the corner (2 sides flamed)					
Rebar Ø8 - Ø20	Fire-resistance grading						Fire-resistance grading					
l_v ²⁾	R30	R60	R90	R120	R180	R240	R30	R60	R90	R120	R180	R240
[mm]	[-]	[-]	[-]	[-]	[-]	[-]	[-]	[-]	[-]	[-]	[-]	[-]
80	0,38	0,14	0,09	0,06	0,04	0,03	0,20	0,08	0,05	0,04	0,03	0,02
90	0,43	0,16	0,10	0,07	0,04	0,03	0,24	0,09	0,06	0,04	0,03	0,02
100	0,49	0,18	0,11	0,07	0,05	0,03	0,28	0,10	0,07	0,05	0,03	0,03
110	0,53	0,21	0,12	0,08	0,05	0,04	0,33	0,12	0,07	0,05	0,04	0,03
120	0,57	0,23	0,13	0,09	0,06	0,04	0,38	0,14	0,08	0,06	0,04	0,03
130	0,60	0,27	0,15	0,10	0,06	0,04	0,43	0,16	0,10	0,07	0,04	0,03
140	0,63	0,30	0,17	0,11	0,07	0,05	0,47	0,19	0,11	0,08	0,05	0,04
150	0,66	0,35	0,19	0,13	0,07	0,05	0,51	0,22	0,13	0,09	0,06	0,04
160	0,68	0,39	0,22	0,14	0,08	0,06	0,54	0,26	0,14	0,10	0,06	0,04
170	0,70	0,42	0,24	0,16	0,09	0,06	0,56	0,30	0,17	0,11	0,07	0,05
180	0,71	0,46	0,28	0,18	0,10	0,07	0,59	0,34	0,19	0,13	0,08	0,05
190	0,73	0,48	0,31	0,20	0,11	0,07	0,61	0,37	0,22	0,15	0,09	0,06
200	0,74	0,51	0,35	0,23	0,12	0,08	0,63	0,40	0,25	0,17	0,10	0,07
210	0,76	0,53	0,38	0,25	0,14	0,09	0,65	0,43	0,29	0,19	0,11	0,07
220	0,77	0,55	0,41	0,28	0,15	0,10	0,66	0,46	0,32	0,22	0,12	0,08
230	0,78	0,57	0,43	0,32	0,17	0,11	0,68	0,48	0,35	0,25	0,14	0,09
240	0,79	0,59	0,46	0,34	0,19	0,12	0,69	0,50	0,38	0,28	0,15	0,10
250	0,79	0,61	0,48	0,37	0,21	0,13	0,70	0,52	0,40	0,31	0,17	0,11
260	0,80	0,62	0,50	0,39	0,23	0,15	0,72	0,54	0,43	0,33	0,20	0,13
270	0,81	0,64	0,52	0,42	0,26	0,16	0,73	0,56	0,45	0,36	0,22	0,14
280	0,82	0,65	0,53	0,44	0,28	0,18	0,74	0,57	0,47	0,38	0,25	0,16
290	0,82	0,66	0,55	0,46	0,31	0,20	0,74	0,59	0,49	0,40	0,27	0,18
300	0,83	0,67	0,56	0,48	0,33	0,22	0,75	0,60	0,50	0,42	0,30	0,20
310	0,83	0,68	0,58	0,49	0,35	0,24	0,76	0,62	0,52	0,44	0,32	0,22
320	0,84	0,69	0,59	0,51	0,37	0,26	0,77	0,63	0,53	0,46	0,34	0,24
350	0,85	0,72	0,63	0,55	0,43	0,33	0,79	0,66	0,57	0,51	0,40	0,31
400	0,87	0,75	0,67	0,61	0,50	0,41	0,82	0,70	0,63	0,57	0,47	0,39
500	0,90	0,80	0,74	0,69	0,60	0,53	0,85	0,76	0,70	0,65	0,58	0,52
600	0,91	0,84	0,78	0,74	0,67	0,61	0,88	0,80	0,75	0,71	0,65	0,60
700	0,93	0,86	0,81	0,78	0,71	0,66	0,89	0,83	0,79	0,75	0,70	0,65
800	0,94	0,88	0,84	0,80	0,75	0,71	0,91	0,85	0,81	0,78	0,74	0,70
900	0,94	0,89	0,85	0,83	0,78	0,74	0,92	0,87	0,83	0,81	0,77	0,73
1000	0,95	0,90	0,87	0,84	0,80	0,76	0,93	0,88	0,85	0,83	0,79	0,76
1500	0,97	0,93	0,91	0,90	0,87	0,84	0,95	0,92	0,90	0,88	0,86	0,84
2000	0,97	0,95	0,93	0,92	0,90	0,88	0,96	0,94	0,93	0,91	0,89	0,88

¹⁾ c_{nom} = concrete cover

²⁾ l_v = embedment length of the bar in the concrete

³⁾ $\bar{k}_{\theta(x)}$ = Mean reduction factor over the embedment depth of the rebar as a function of the temperature profile

Intermediate values of $\bar{k}_{\theta(x)}$ may be interpolated linearly. Extrapolation is not permitted.

Endanchoring - Mean reduction factor under fire exposure $\bar{k}_{\theta(x)}$ ³⁾												
$c_{nom} = 30$ mm ¹⁾	Rebar at the edge (1 side flamed)						Rebar at the corner (2 sides flamed)					
Rebar Ø8 - Ø28	Fire-resistance grading						Fire-resistance grading					
l_v ²⁾	R30	R60	R90	R120	R180	R240	R30	R60	R90	R120	R180	R240
[mm]	[-]	[-]	[-]	[-]	[-]	[-]	[-]	[-]	[-]	[-]	[-]	[-]
80	0,59	0,20	0,11	0,08	0,05	0,03	0,33	0,11	0,07	0,05	0,03	0,03
90	0,64	0,22	0,12	0,08	0,05	0,04	0,37	0,12	0,07	0,05	0,04	0,03
100	0,68	0,24	0,13	0,09	0,05	0,04	0,42	0,14	0,08	0,06	0,04	0,03
110	0,71	0,27	0,15	0,10	0,06	0,04	0,47	0,15	0,09	0,06	0,04	0,03
120	0,73	0,29	0,16	0,11	0,06	0,04	0,51	0,17	0,10	0,07	0,05	0,03
130	0,75	0,32	0,17	0,11	0,07	0,05	0,55	0,19	0,11	0,08	0,05	0,04
140	0,77	0,36	0,19	0,12	0,07	0,05	0,58	0,22	0,12	0,08	0,05	0,04
150	0,78	0,39	0,21	0,14	0,08	0,05	0,61	0,25	0,14	0,09	0,06	0,04
160	0,80	0,43	0,23	0,15	0,08	0,06	0,63	0,28	0,15	0,10	0,06	0,05
170	0,81	0,46	0,25	0,16	0,09	0,06	0,66	0,31	0,17	0,11	0,07	0,05
180	0,82	0,49	0,28	0,18	0,10	0,07	0,68	0,35	0,19	0,13	0,08	0,05
190	0,83	0,52	0,31	0,19	0,11	0,07	0,69	0,38	0,21	0,14	0,08	0,06
200	0,84	0,55	0,34	0,21	0,11	0,08	0,71	0,41	0,24	0,16	0,09	0,06
210	0,85	0,57	0,37	0,23	0,12	0,08	0,72	0,44	0,27	0,17	0,10	0,07
220	0,85	0,59	0,40	0,26	0,14	0,09	0,73	0,47	0,30	0,19	0,11	0,08
230	0,86	0,60	0,42	0,28	0,15	0,10	0,75	0,49	0,33	0,22	0,12	0,08
240	0,86	0,62	0,45	0,31	0,16	0,10	0,76	0,51	0,36	0,24	0,13	0,09
250	0,87	0,64	0,47	0,34	0,18	0,11	0,77	0,53	0,38	0,27	0,15	0,10
260	0,88	0,65	0,49	0,36	0,19	0,12	0,78	0,55	0,41	0,30	0,16	0,11
270	0,88	0,66	0,51	0,39	0,21	0,13	0,78	0,57	0,43	0,32	0,18	0,12
280	0,88	0,68	0,53	0,41	0,23	0,15	0,79	0,58	0,45	0,35	0,20	0,13
290	0,89	0,69	0,54	0,43	0,25	0,16	0,80	0,60	0,47	0,37	0,22	0,14
300	0,89	0,70	0,56	0,45	0,28	0,17	0,81	0,61	0,48	0,39	0,24	0,16
310	0,90	0,71	0,57	0,46	0,30	0,19	0,81	0,62	0,50	0,41	0,27	0,17
320	0,90	0,72	0,58	0,48	0,32	0,20	0,82	0,63	0,52	0,43	0,29	0,19
350	0,91	0,74	0,62	0,53	0,38	0,26	0,83	0,66	0,56	0,48	0,35	0,25
400	0,92	0,77	0,67	0,59	0,46	0,35	0,85	0,71	0,61	0,54	0,43	0,34
500	0,94	0,82	0,73	0,67	0,57	0,48	0,88	0,77	0,69	0,63	0,55	0,47
600	0,95	0,85	0,78	0,72	0,64	0,57	0,90	0,80	0,74	0,70	0,62	0,56
700	0,95	0,87	0,81	0,76	0,69	0,63	0,92	0,83	0,78	0,74	0,68	0,62
800	0,96	0,89	0,83	0,79	0,73	0,68	0,93	0,85	0,81	0,77	0,72	0,67
900	0,96	0,90	0,85	0,82	0,76	0,71	0,94	0,87	0,83	0,80	0,75	0,71
1000	0,97	0,91	0,87	0,83	0,78	0,74	0,94	0,88	0,85	0,82	0,77	0,74
1500	0,98	0,94	0,91	0,89	0,86	0,83	0,96	0,92	0,90	0,88	0,85	0,82
2000	0,98	0,95	0,93	0,92	0,89	0,87	0,97	0,94	0,92	0,91	0,89	0,87

¹⁾ c_{nom} = concrete cover

²⁾ l_v = embedment length of the bar in the concrete

³⁾ $\bar{k}_{\theta(x)}$ = Mean reduction factor over the embedment depth of the rebar as a function of the temperature profile

Intermediate values of $\bar{k}_{\theta(x)}$ may be interpolated linearly. Extrapolation is not permitted.

Endanchoring - Mean reduction factor under fire exposure $\bar{k}_{\theta(x)}$ ³⁾												
$c_{nom} = 40$ mm ¹⁾	Rebar at the edge (1 side flamed)						Rebar at the corner (2 sides flamed)					
Rebar Ø8 - Ø40	Fire-resistance grading						Fire-resistance grading					
l_v ²⁾	R30	R60	R90	R120	R180	R240	R30	R60	R90	R120	R180	R240
[mm]	[-]	[-]	[-]	[-]	[-]	[-]	[-]	[-]	[-]	[-]	[-]	[-]
80	0,87	0,29	0,15	0,10	0,06	0,04	0,58	0,17	0,10	0,07	0,04	0,03
90	0,88	0,31	0,16	0,10	0,06	0,04	0,62	0,19	0,10	0,07	0,04	0,03
100	0,89	0,33	0,17	0,11	0,06	0,04	0,66	0,20	0,11	0,08	0,05	0,04
110	0,90	0,35	0,18	0,12	0,06	0,05	0,69	0,22	0,12	0,08	0,05	0,04
120	0,91	0,38	0,19	0,12	0,07	0,05	0,72	0,24	0,13	0,09	0,05	0,04
130	0,92	0,41	0,21	0,13	0,07	0,05	0,74	0,26	0,14	0,09	0,06	0,04
140	0,92	0,44	0,22	0,14	0,08	0,05	0,76	0,28	0,15	0,10	0,06	0,04
150	0,93	0,47	0,24	0,15	0,08	0,06	0,77	0,31	0,16	0,11	0,06	0,05
160	0,93	0,50	0,25	0,16	0,09	0,06	0,79	0,34	0,18	0,12	0,07	0,05
170	0,94	0,53	0,27	0,17	0,09	0,06	0,80	0,37	0,19	0,13	0,07	0,05
180	0,94	0,56	0,29	0,18	0,10	0,06	0,81	0,40	0,21	0,14	0,08	0,06
190	0,94	0,58	0,31	0,19	0,10	0,07	0,82	0,43	0,23	0,15	0,09	0,06
200	0,95	0,60	0,34	0,21	0,11	0,07	0,83	0,46	0,25	0,16	0,09	0,06
210	0,95	0,62	0,36	0,22	0,12	0,08	0,84	0,49	0,27	0,17	0,10	0,07
220	0,95	0,64	0,39	0,24	0,12	0,08	0,85	0,51	0,30	0,19	0,11	0,07
230	0,95	0,65	0,42	0,26	0,13	0,09	0,85	0,53	0,32	0,21	0,11	0,08
240	0,96	0,67	0,44	0,27	0,14	0,09	0,86	0,55	0,35	0,22	0,12	0,08
250	0,96	0,68	0,46	0,30	0,15	0,10	0,86	0,57	0,38	0,24	0,13	0,09
260	0,96	0,69	0,48	0,32	0,16	0,10	0,87	0,59	0,40	0,26	0,14	0,10
270	0,96	0,71	0,50	0,34	0,17	0,11	0,87	0,60	0,42	0,29	0,15	0,10
280	0,96	0,72	0,52	0,36	0,19	0,12	0,88	0,62	0,44	0,31	0,17	0,11
290	0,96	0,73	0,54	0,39	0,20	0,13	0,88	0,63	0,46	0,34	0,18	0,12
300	0,96	0,74	0,55	0,41	0,21	0,13	0,89	0,64	0,48	0,36	0,20	0,13
310	0,97	0,74	0,57	0,43	0,23	0,14	0,89	0,65	0,50	0,38	0,21	0,14
320	0,97	0,75	0,58	0,44	0,24	0,15	0,89	0,66	0,51	0,40	0,23	0,15
350	0,97	0,77	0,62	0,49	0,30	0,19	0,90	0,69	0,55	0,45	0,29	0,18
400	0,97	0,80	0,66	0,55	0,39	0,26	0,92	0,73	0,61	0,52	0,38	0,26
500	0,98	0,84	0,73	0,64	0,51	0,40	0,93	0,79	0,69	0,61	0,50	0,41
600	0,98	0,87	0,78	0,70	0,59	0,50	0,94	0,82	0,74	0,68	0,58	0,51
700	0,98	0,89	0,81	0,75	0,65	0,57	0,95	0,85	0,78	0,72	0,64	0,58
800	0,99	0,90	0,83	0,78	0,69	0,63	0,96	0,87	0,81	0,76	0,69	0,63
900	0,99	0,91	0,85	0,80	0,73	0,67	0,96	0,88	0,83	0,79	0,72	0,67
1000	0,99	0,92	0,87	0,82	0,75	0,70	0,97	0,89	0,84	0,81	0,75	0,70
1500	0,99	0,95	0,91	0,88	0,84	0,80	0,98	0,93	0,90	0,87	0,83	0,80
2000	0,99	0,96	0,93	0,91	0,88	0,85	0,98	0,95	0,92	0,90	0,88	0,85

¹⁾ c_{nom} = concrete cover

²⁾ l_v = embedment length of the bar in the concrete

³⁾ $\bar{k}_{\theta(x)}$ = Mean reduction factor over the embedment depth of the rebar as a function of the temperature profile

Intermediate values of $\bar{k}_{\theta(x)}$ may be interpolated linearly. Extrapolation is not permitted.

The bond strength $f_{bd,PIR}$ depends on the concrete class and rebar diameter as well as on the corresponding conversion factor $f_{bd,fi,con}$ and can be found for rebar at the corner or at the edge in the following table:

Concrete class	Ø-Rebar	$f_{bd,PIR}$ (all drilling methods)	$f_{bd,fi,con}$ - Factor
[-]	[mm]	[N/mm ²]	[-]
C12/15	Ø8 - Ø34	1,6	1,44
	Ø36, Ø40	1,5	1,53
C16/20	Ø8 - Ø34	2,0	1,15
	Ø36	1,9	1,21
	Ø40	1,8	1,28
C20/25	Ø8 - Ø34	2,3	1,00
	Ø36	2,2	1,05
	Ø40	2,1	1,10
C25/30	Ø8 - Ø32	2,7	0,85
	Ø34, Ø36	2,6	0,88
	Ø40	2,5	0,92
C30/37	Ø8 - Ø32	3,0	0,77
	Ø34, Ø36	2,9	0,79
	Ø40	2,8	0,82
C35/45	Ø8 - Ø32	3,4	0,68
	Ø34, Ø36	3,3	0,70
	Ø40	3,1	0,74
C40/50	Ø8 - Ø32	3,7	0,62
	Ø34, Ø36	3,6	0,64
	Ø40	3,4	0,68
C45/55	Ø8 - Ø32	4,0	0,58
	Ø34	3,9	0,59
	Ø36	3,8	0,61
	Ø40	3,7	0,62
C50/60	Ø8 - Ø32	4,3	0,53
	Ø34	4,2	0,55
	Ø36	4,1	0,56
	Ø40	4,0	0,58

The given values does not deal with the mechanical design at ambient temperature, these shall be done in addition and related to ETA-19/0200.

Post-installed rebar connections shall be designed in ambient temperature conditions before being designed in fire conditions.

The bond resistance $f_{bd,fi}$ shall not be applied for beam to beam connections.

The partial safety factor for actions can be assumed to be $\gamma_F = 1.0$ for determining recommended loads.

4. Chemical resistance

Chemical Agent	Concentration	Resistant	Not resistant
Accumulator acid			X
Acetic acid	10%		X
Acetic acid	40%		X
Laitance		X	
Acetone	5%		X
Acetone	10%		X
Acetone	100%		X
Ammonia, aqueous solution	5%	X	
Ammonia, aqueous solution	32%		X
Aniline	100%		X
Beer	100%	X	
Chlorine	All	X	
Benzol	100%		X
Boric Acid, aqueous solution		X	
Calcium carbonate, suspended in water	All	X	
Calcium chloride, suspended in water		X	
Calcium hydroxide, suspended in water		X	
Chlorinated lime (Calcium hypochlorite)	10%		X
Carbon tetrachloride	100%	X	
Caustic soda solution	10%	X	
Caustic soda solution	40%	X	
Citric acid	10%		X
Citric acid	50%		X
Citric acid	All	X	
Chlorine water, swimming pool	All		X
Deminerlized water	All		X
Diesel oil	100%	X	
Ethyl alcohol, aqueous solution	100%		X
Ethyl alcohol, aqueous solution	50%		X
Formic acid	10%	X	
Formic acid	30%		X
Formic acid	100%		X
Formaldehyde, aqueous solution	20%	X	
Formaldehyde, aqueous solution	30%	X	
Freon		X	
Fuel Oil		X	
Gasoline (premium grade)	100%	X	
Glycol (Ethylene glycol)		X	
Hydraulic fluid	Conc.		X
Hydrochloric acid (Muriatic Acid)	Conc.		X
Hydrogen peroxide	10%		X
Hydrogen peroxide	30%		X
Isopropyl alcohol	100%		X
Lactic acid	10%		X
Lactic acid	All		X
Linseed oil	100%	X	
Lubricating oil	100%	X	
Magnesium chloride, aqueous solution	All	X	
Methanol	100%		X
Standard benzine			X
Motor oil (SAE 20 W-50)	100%	X	
Nitric acid	10%		X
Oleic acid	100%	X	
Perchloroethylene	100%	X	
Petroleum	100%	X	
Phenol, aqueous solution	8%		X

Results shown in the table are applicable to brief periods of chemical contact with full cured adhesive (e.g. temporary contact with adhesive during a spill).

Chemical Agent	Concentration	Resistant	Not resistant
Benzyl alcohol	100%		x
Phosphoric acid	85%	x	
Phosphoric acid	10%	x	
Potash lye (Potassium hydroxide)	10%	x	
Potash lye (Potassium hydroxide)	40%	x	
Potassium carbonate, aqueous solution	All	x	
Potassium chlorite, aqueous solution	All	x	
Potassium nitrate, aqueous solution	All	x	
Sea water, salty	All	x	
Sodium carbonate	All	x	
Sodium chloride, aqueous solution	All	x	
Sodium phosphate, aqueous solution	All	x	
Sodium silicate	All	x	
Sulfuric acid	10%		x
Sulfuric acid	30%		x
Sulfuric acid	70%		x
Tartaric acid	All	x	
Tetrachloroethylene	100%	x	
Toluene			x
Trichloroethylene	100%		x
Turpentine	100%	x	

Results shown in the table are applicable to brief periods of chemical contact with full cured adhesive (e.g. temporary contact with adhesive during a spill).