

Body-Solid[®]

Built for Life

GDC210.1

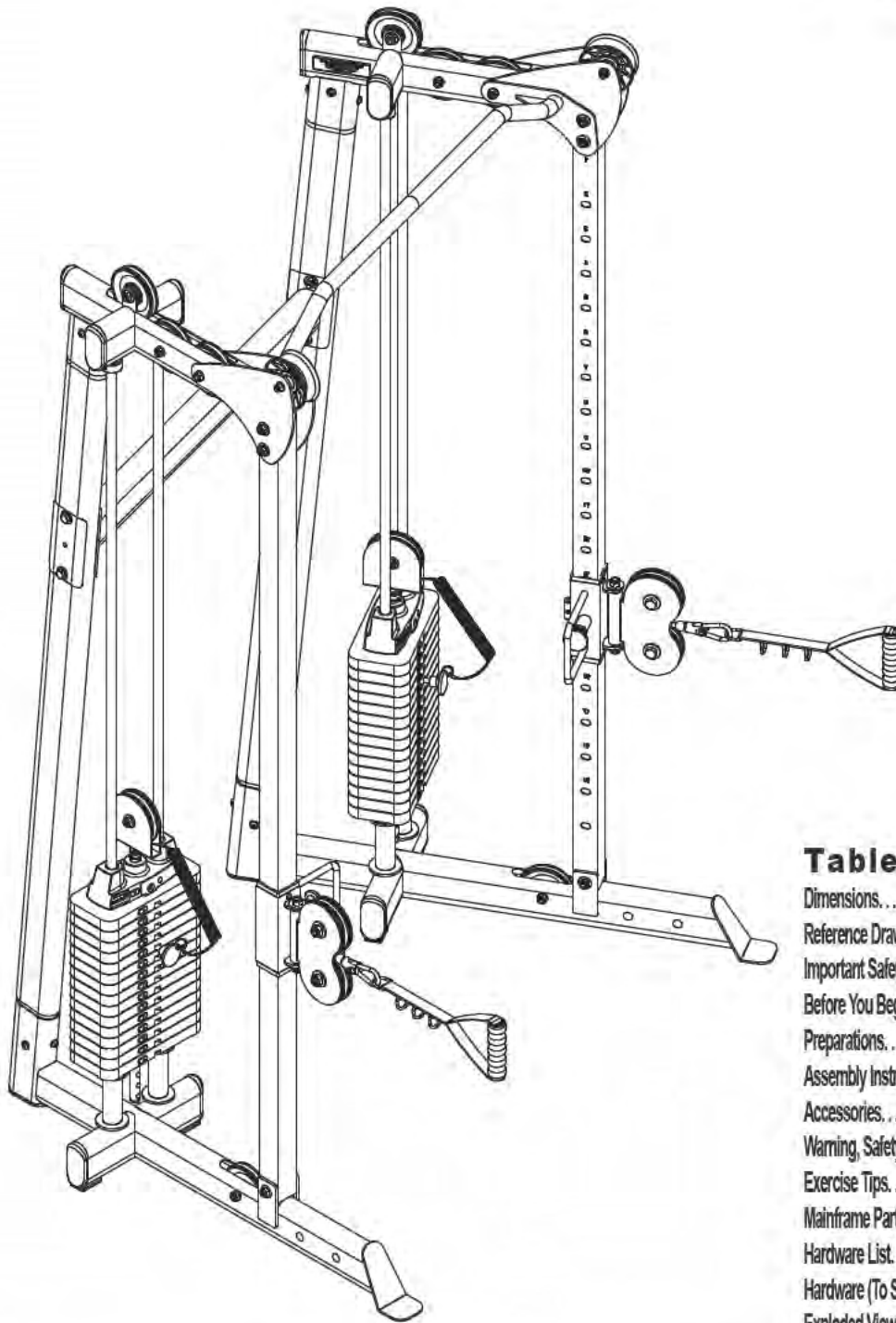

Table of Contents

Dimensions.....	p. 2
Reference Drawings.....	p. 3
Important Safety Instructions.....	p. 4
Before You Begin.....	p. 5
Preparations.....	p. 6
Assembly Instructions.....	p. 7-25
Accessories.....	p. 26-27
Warning, Safety & Maintenance.....	p. 28-31
Exercise Tips.....	p. 32-51
Mainframe Parts List.....	p. 52
Hardware List.....	p. 52-53
Hardware (To Scale).....	p. 54-57
Exploded View Diagram.....	p. 58-59

Assembly Instructions

OWNER'S & MANUAL

Dimensions

The room layout diagram below will help you decide the best placement for your GDCC210.

The dimensions of the GDCC210 are: Width 3' 6" X Length 4' 10".

The ceiling height requirement for the GDCC210 is 6' 11".

The usage space is: Width 5' 6" X Length 7' (The usage space is the overall space needed for operation).

The usage space needed for the GDCC210 could be more, depending on the user.

Minimum Usage Space

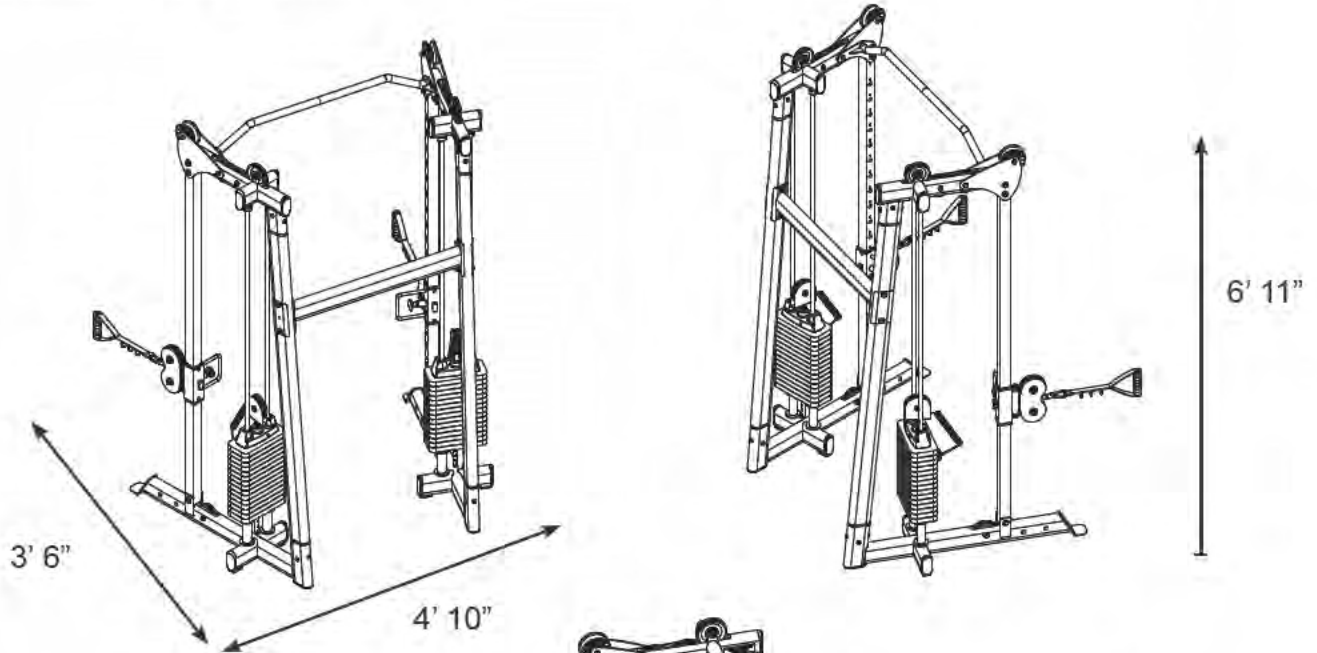

Suggested Usage Space

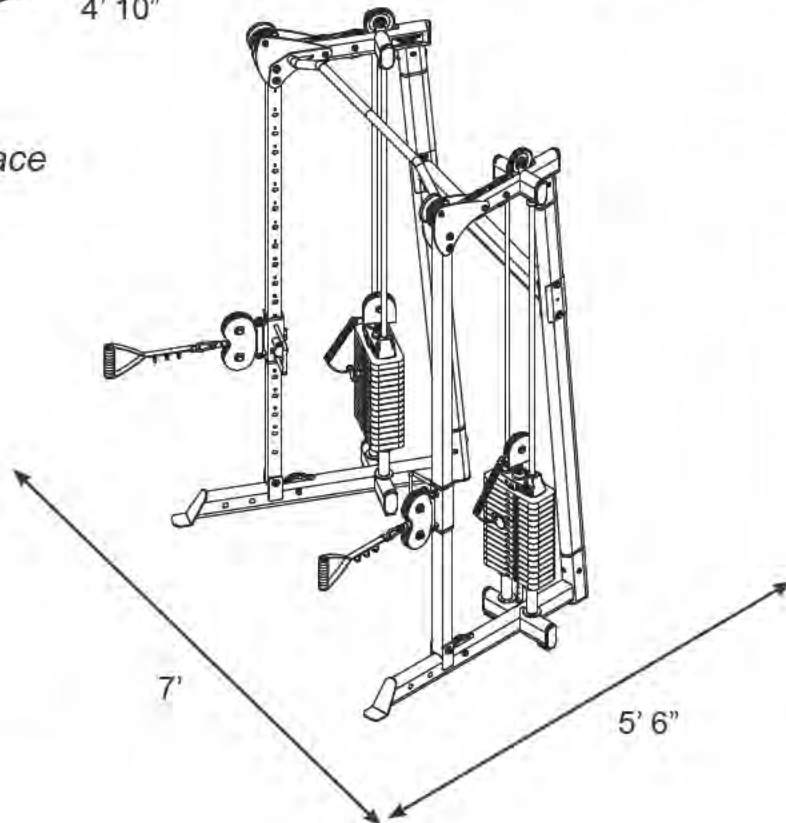

GDCC210 Reference Drawings

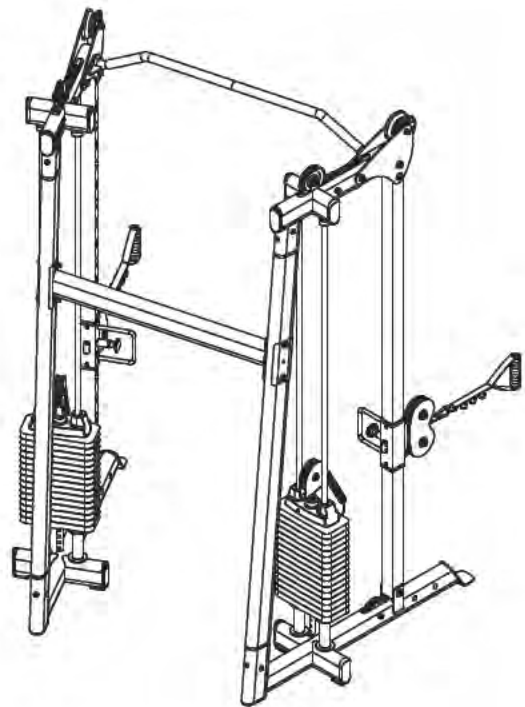
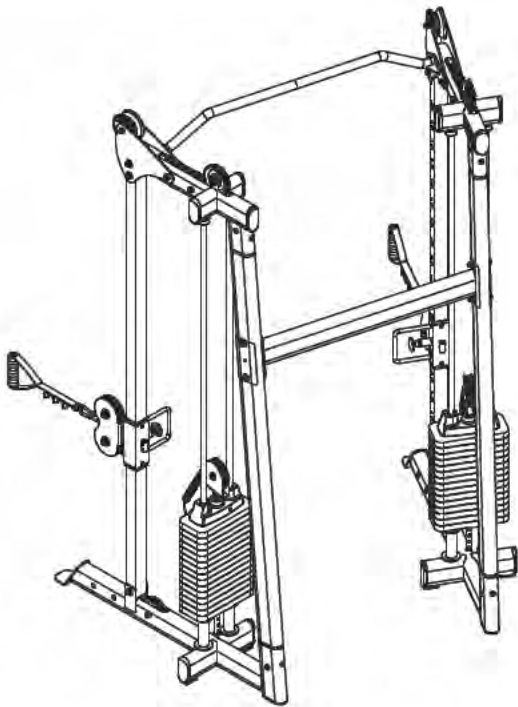
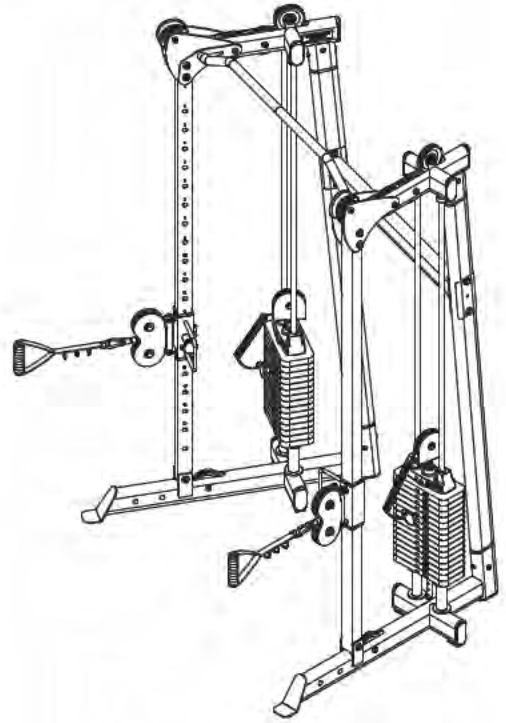
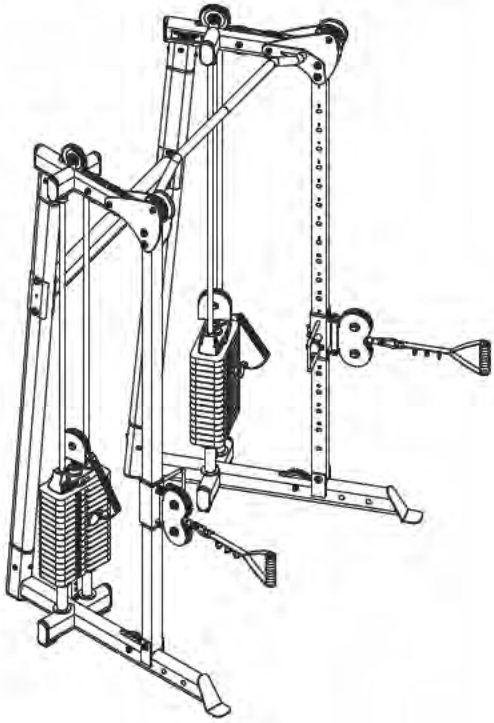

Note: Due to continuing product improvements, specifications and designs are subject to change without notice.

Even though we have prepared this manual with extreme care, neither the publisher nor the author can accept responsibility for any errors in, or omission from, the information given.

Important Safety Instructions

Before beginning any fitness program, you should obtain a complete physical examination from your physician.

*Il est conseillé de subir un examen médical complet avant d'entreprendre tout programme d'exercice.
Si vous avez des étourdissements ou des faiblesses, arrêtez les exercices immédiatement.*

Antes de comenzar cualquier programa de ejercicios, deberías tener un examen físico con su doctor.

When using exercise equipment, you should always take basic precautions, including the following:

- Read all instructions before using the GDCC210. These instructions are written to ensure your safety and to protect the unit.
- Do not allow children on or near the equipment.
- Use the equipment only for its intended purpose as described in this guide. Do not use accessory attachments that are not recommended by the manufacturer. Such attachments might cause injuries.
- Wear proper exercise clothing and shoes for your workout, no loose clothing.
- Use care when getting on or off the unit.
- Do not overexert yourself or work to exhaustion.
- If you feel any pain or abnormal symptoms, stop your workout immediately and consult your physician.
- Never operate the unit when it has been dropped or damaged. Return the equipment to a service center for examination and repair.
- Never drop or insert objects into any opening in the equipment.
- Always check the unit before each use. Make sure that all fasteners are secure and in good working condition.
- Do not use the equipment outdoors or near water.

Personal Safety During Assembly

- It is strongly recommended that a qualified dealer assemble the equipment.
Assistance is required.
- Before beginning assembly, please take the time to read the instructions thoroughly.
- Read each step in the assembly instructions and follow the steps in sequence. Do not skip ahead. If you skip ahead, you may learn later that you have to disassemble components and that you may have damaged the equipment.
- Assemble and operate the GDCC210 on a solid, level surface. Locate the unit a few feet from the walls or furniture to provide easy access.

The GDCC210 is designed for your enjoyment. By following these precautions and using common sense, you will have many safe and pleasurable hours of healthful exercise with your Body-Solid GDCC210.

After assembly, you should check all functions to ensure correct operation. If you experience problems, first re-check the assembly instructions to locate any possible errors made during assembly. If you are unable to correct the problem, call the dealer from whom you purchased the machine or call 1-800-556-3113 for the dealer nearest you.

Obtaining Service

Please use this Owner's Manual to make sure that all parts have been included in your shipment. When ordering parts, you must use the part number and description from this Owner's Manual. Use only Body-Solid replacement parts when servicing this unit. Failure to do so will void your warranty and could result in personal injury.

For information about product operation or service, check out the official Body-Solid website at www.bodysolid.com or contact an authorized Body-Solid dealer or a Body-Solid factory-authorized service company or contact Body-Solid customer service at one of the following:

Toll Free: 1-800-556-3113
Phone: 1-708-427-3555
Fax: 1-708-427-3556
Hours: M-F 8:30-5:00 CST
E-Mail: service@bodysolid.com

Or write to: Body-Solid, Inc.
Service Department
1900 S. Des Plaines Ave.
Forest Park, IL 60130 USA

Retain this Owner's Manual for future reference. Part numbers are required when ordering replacement parts.

Before You Begin

Thank you for purchasing the GDCC210. This gym is part of the Body-Solid line of quality strength training machines, which let you target specific muscle groups to achieve better muscle tone and overall body conditioning. To maximize your use of the equipment please study this Owner's Manual thoroughly.

Unpacking the Equipment

The GDCC210 is carefully tested and inspected before shipment. We have shipped the unit in several pieces that require assembly. Ask for assistance during the assembly process. Carefully unpack the boxes and lay the pieces on the floor near the area where you plan to use the equipment.

Be careful to assemble all components in the sequence presented in this guide.

If any items are missing, contact the dealer from whom you purchased the unit or call 1-800-556-3113 for the dealer nearest you.

! DANGER !

MAXIMUM 1 USER AT A TIME

Usage by two or more users is not permitted at any time.

Death or serious injuries will result with improper exercise.

Use only the weight stack supplied by the manufacturer.

DO NOT add additional resistance, unauthorized accessories or attachments to the machine.

Never pin the weight stack or top plate into an elevated position.

Body-Solid continually seeks ways to improve the performance, specifications and product manuals in order to ensure that only superior products are released from our factories. Please take the time to carefully read through this manual thoroughly. Instructions contained in this document are not intended to cover all details or variations possible with Body-Solid equipment, or to cover every contingency that may be met in conjunction with installation, operation, maintenance or troubleshooting of the equipment. Even though we have prepared this manual with extreme care, neither the publisher nor the author can accept responsibility for any errors in, or omission from, the information given. Should additional information be required, or should situations arise that are not covered by this manual, the matter should be directed to your local Body-Solid representative, or the Service Department at Body-Solid Inc. in Forest Park, Illinois.

Any Questions?
Call (800) 556-3113

Preparations

CAUTION: To set up this unit, you will need assistance. Do not attempt assembly by yourself.

You must review and follow the instructions in this Owner's Manual. If you do not assemble and use the GDCC210 according to these guidelines, you could void the Body-Solid warranty.

Required Tools

The basic tools that you must obtain before assembling the GDCC210 include but are not limited to:

- Standard Wrench Set
- Metric Wrench Set
- Adjustable Wrench
- Allen Set
- Rubber Mallet
- Silicone Spray Oil
- Knife

CAUTION: Obtain assistance! Do not attempt to assemble the GDCC210 by yourself. Review the Installation Requirements before proceeding with the following steps.

Be careful to assemble components in the sequence presented in this guide.

NOTE: With so many assembled parts, proper alignment and adjustment is critical. While tightening the nuts and bolts, be sure to leave room for adjustments.

Installation Requirements

Follow these installation requirements when assembling the GDCC210:

Set up the GDCC210 on a solid, flat surface. A smooth, flat surface under the machine helps keep it level. A level machine has fewer malfunctions.

Provide ample space around the machine. Open space around the machine allows for easier access.

Insert all bolts in the same direction. For aesthetic purposes, insert all bolts in the same direction unless specified (in text or illustrations) to do otherwise.

Leave room for adjustments. Tighten fasteners such as bolts, nuts, and screws so the unit is stable, but leave room for adjustments. Do not fully tighten fasteners until instructed in the assembly steps to do so.

Fill out and mail the warranty card.

Assembly Instructions

Assembly of the GDCC210 takes professional installers about 2 hours to complete. If this is the first time you have assembled this type of equipment, plan on significantly more time.

Professional installers are highly recommended!

However, if you acquire the appropriate tools, obtain assistance, and follow the assembly steps sequentially, the process will take time, but is fairly easy.

Assembly Tips

Read all "Notes" on each page before beginning each step.

While you may be able to assemble the GDCC210 using the illustrations only, important safety notes and other tips are included in the text.

Some pieces may have extra holes that you will not use. Use only those holes indicated in the instructions and illustrations.

NOTE: To find out the length of a particular bolt, measure its shank (the long, narrow part beneath the head). Refer to the following diagram:

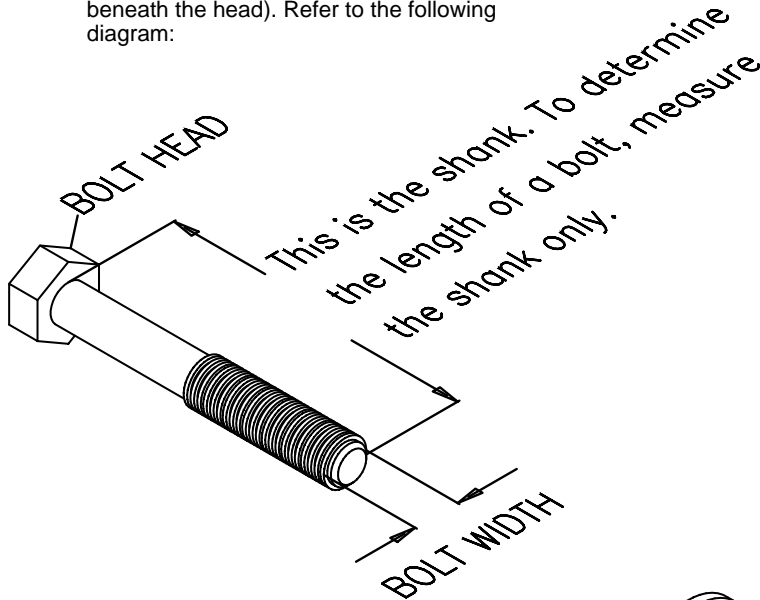

IMPORTANT!

Before you begin you should look at the quick reference guide that shows all hardware parts (in actual size) along with the corresponding key numbers on the assembly instructions.

Do not fully tighten bolts until instructed to do so.

Note: After assembly, you should check all functions to ensure correct operation. If you experience **problems, first recheck the assembly instructions** to locate any possible errors made during assembly. If you are unable to correct the problem, call the dealer from whom you purchased the machine or call 1-800-556-3113 for the dealer nearest you.

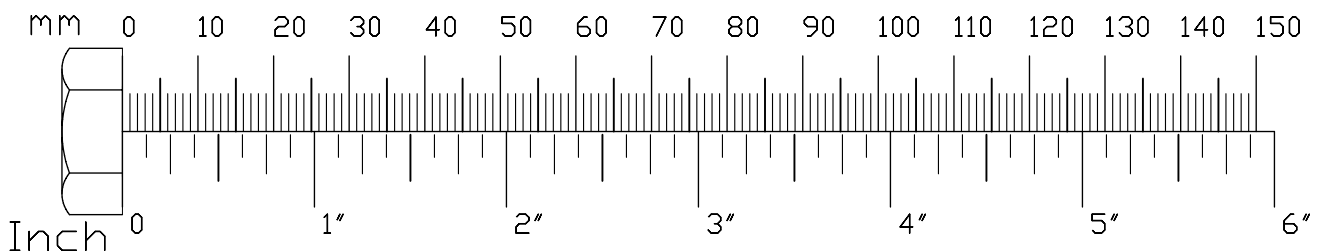
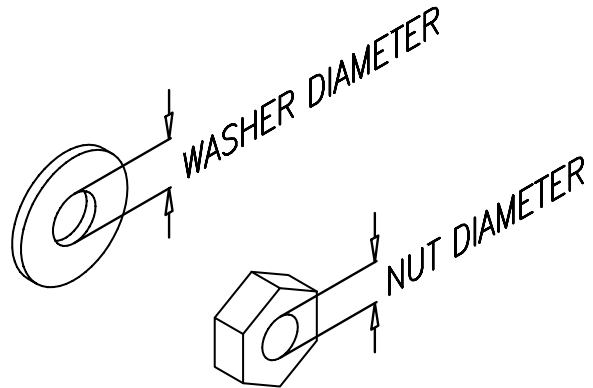

STEP

1

Be careful to assemble all components in the sequence they are presented.

Finger tighten all hardware in this step unless otherwise noted.

RIGHT SIDE ASSEMBLY

Crossover Cable (36)

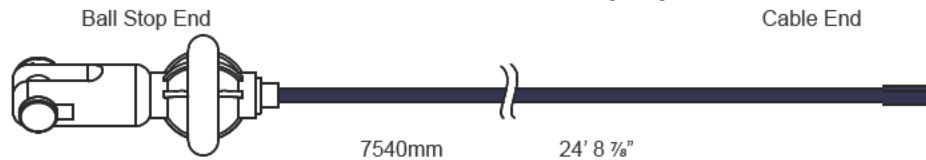

NOTE: Installation begins with the Right Side assembly of the GDCC.
Once completed, the Left Side assembly of the GDCC will be installed.

- A. Insert both Foot Caps (34) into Base Frame (A).
- B. Insert End Cap (46) into Base Frame (A).
- C. Insert four Round End Caps (45) into Base Frame (A).
- D. Slide Guide Post (G) into Base Frame (A) and secure using:
One 3 (M10x75 hex head bolt)
Two 19 (M10 washer)
One 13 (M10 nylon nut)
- E. Insert both Nylon Bushings (31) into Handle (D).
- F. Slide Handle (D) onto Guide Post (G) noting the direction of the Pop Pin on Handle (D) aligns with the pre-punched holes on Guide Post (G).

NOTE: Make sure both Nylon Bushings (31) fit securely into Handle (D).
Silicone Oil may be used to lubricate Guide Post (D) to ease Handle (D) installation.

- G. Insert Lower Pulley (26) into Double Pulley Holder (55) and secure using:
One 1 (1/2" x 50mm hex head bolt)
Two 17 (1/2" washer)
One 14 (1/2" nylon nut)
- H. Install Upper Pulley (26) and the Cable End of Crossover Cable (36) to Double Pulley Holder (55) as shown using:
One 1 (1/2" x 50mm hex head bolt)
Two 17 (1/2" washer)
One 14 (1/2" nylon nut)

NOTE: Let Crossover Cable (36) hang.
This will speed up the assembly process in later steps.

- I. Insert Pulley (25) into Base Frame (A) and secure using:
One 4 (M10x65 hex head bolt)
Two 28 (16.5mm steel bushing)
One 13 (M10 nylon nut)
- J. Connect Handle (39) to Snap Link (30), then attach Snap Link (30) to the Ball Stop End of Crossover Cable (36) as shown in the diagram.

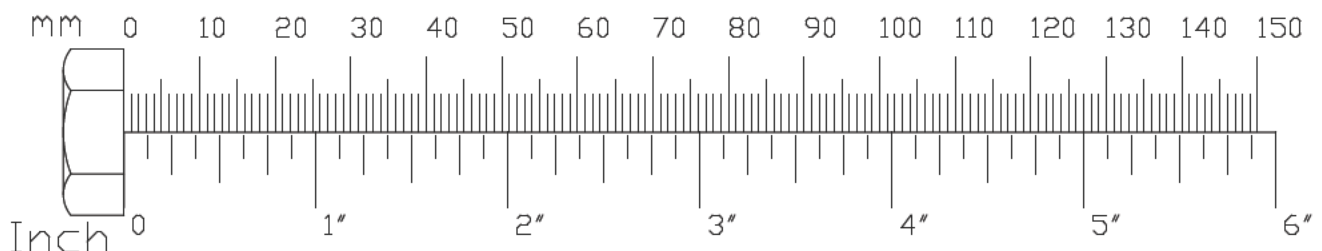

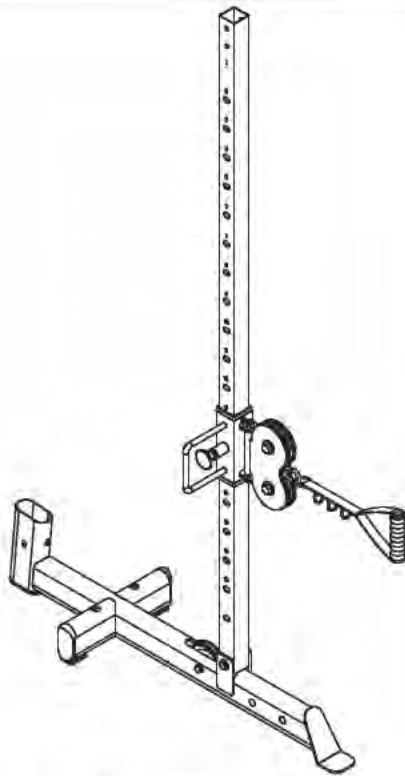

Above shows Step 1 assembled and completed.

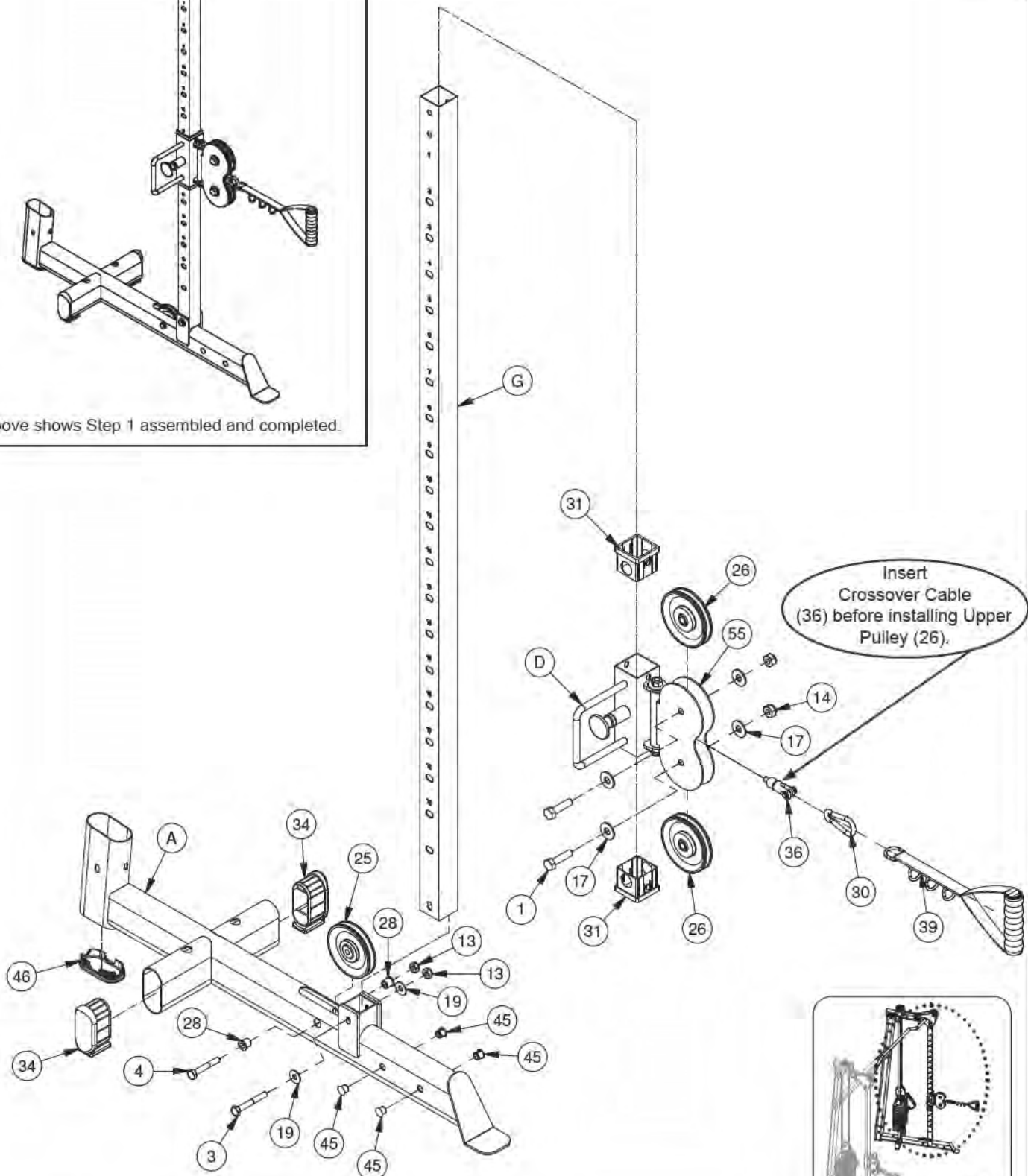

Insert Crossover Cable (36) before installing Upper Pulley (26).

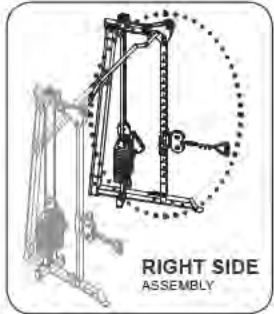

STEP**2**

Be careful to assemble all components in the sequence they are presented.

Finger tighten all hardware in this step unless otherwise noted.

RIGHT SIDE ASSEMBLY

- A. Insert Upright Frame (F) into Base Frame (A) and secure using:
- Two 8 (M8x15 hex head bolt)
 - Two 9 (M8x20 hex head bolt)
 - Two 20 (M8 arc washer)
 - Two 21 (M8 washer)

NOTE: Pay special attention to the orientation of Upright Frame (F) as shown in the diagram. Make sure the pre-drilled holes are positioned closest to Top Frame (B).

- B. Insert three End Caps (33) into Top Frame (B) as shown.
- C. Connect Pulley #3 (25) to Top Frame (B) using:
- One 5 (M10x45 hex head bolt)
 - Two 19 (M10 washer)
 - One 13 (M10 nylon nut)
- D. Connect Pulley #6 (25) to Top Frame (B) and secure using:
- One 6 (M10x85 hex head bolt)
 - One 37 (steel bushing)
 - One 29 (steel bushing)
 - One 13 (M10 nylon nut)
- E. Place Top Frame (B) onto Upright Frame (F) and Guide Post (G) and secure using:
- Two 9 (M8x20 hex head bolt)
 - Two 8 (M8x15 hex head bolt)
 - Two 21 (M8 washer)
 - Two 20 (M8 arc washer)
 - Two 6 (M10x80 hex head bolt)
 - Four 19 (M10 washer)
 - Two 13 (M10 nylon nut)

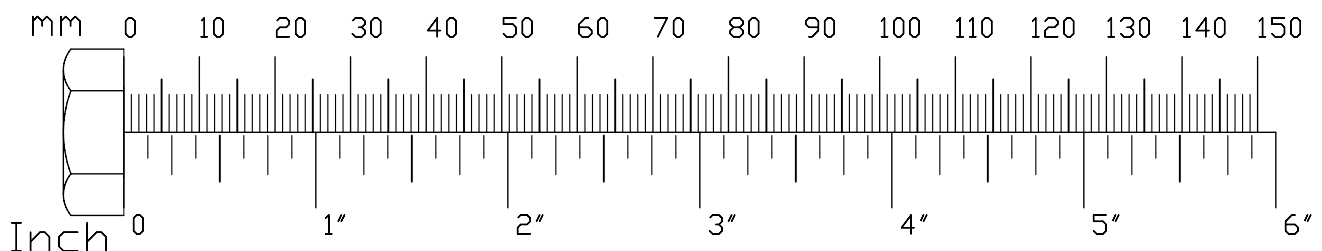

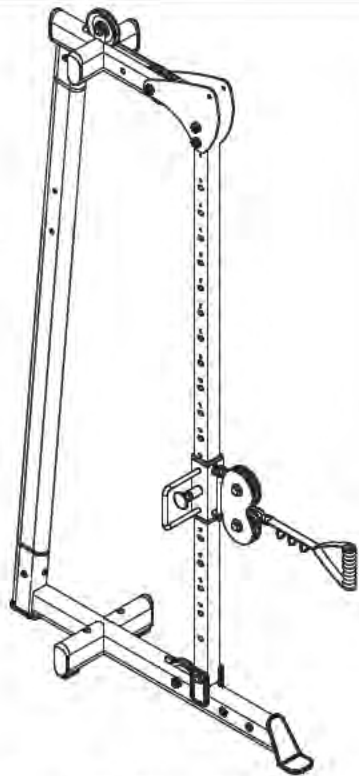

Above shows Step 2 assembled and completed.

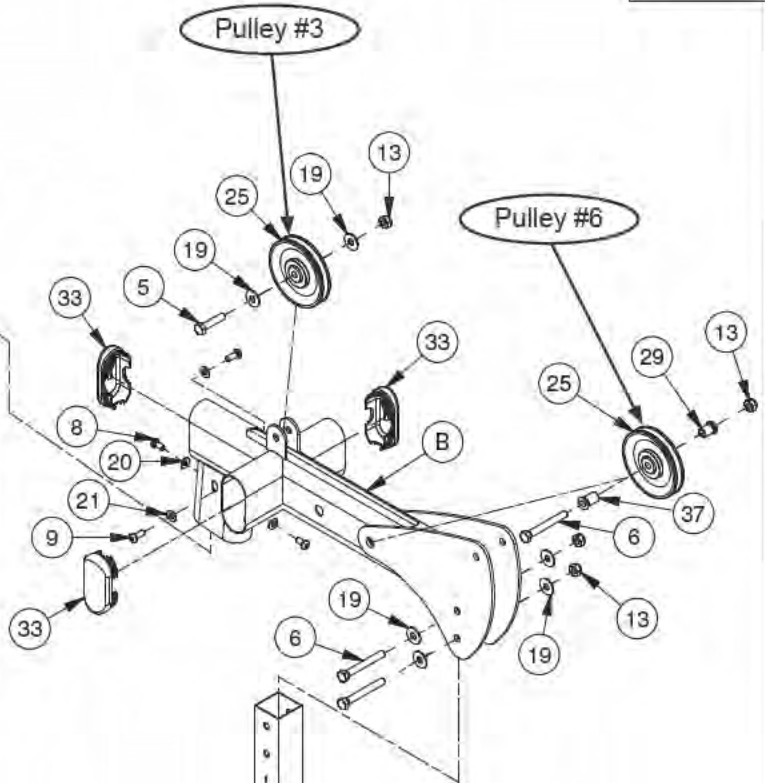

Pre-Drilled Holes

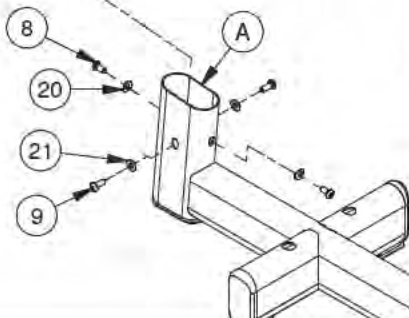
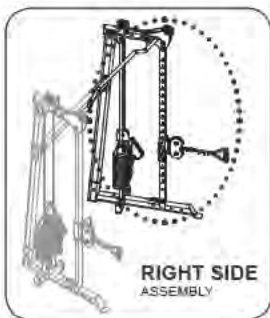
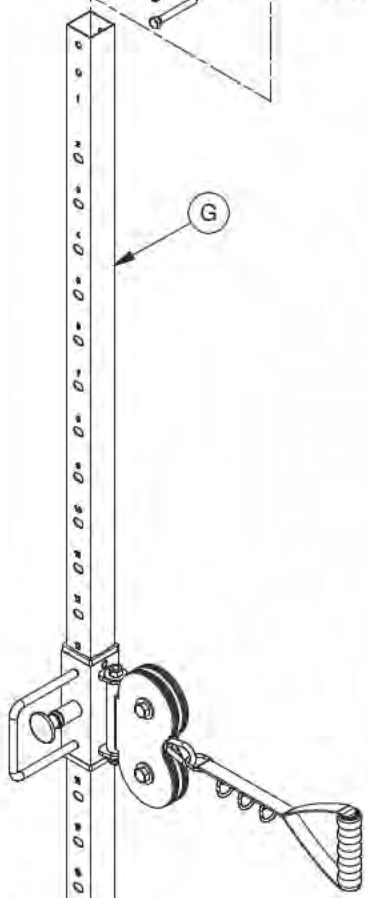
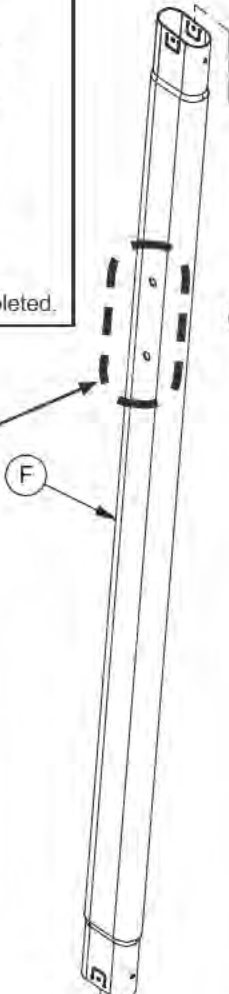

STEP**3**

Be careful to assemble all components in the sequence they are presented.

Finger tighten all hardware in this step unless otherwise noted.

RIGHT SIDE ASSEMBLY

- A. Insert Pulley (25) into Top Frame (B) and secure using:
One 4 (M10x65 hex head bolt)
One 13 (M10 nylon nut)
Two 28 (steel bushing)
- B. Insert Pulley (27) into Top Frame (B) and secure using:
One 2 (3/8" x 3" hex head bolt)
Two 18 (3/8" washer)
One 12 (3/8" nylon nut)
- C. Place both Weight Stack Risers (50) onto Base Frame (A) as shown in the diagram.
NOTE: Weight Stack Risers are omitted when using the upgrade 310 Lb Weight Stack.
- D. Place a Rubber Donut (35) onto each Weight Stack Riser (50) or onto Base Frame (A) if Weight Stack Risers (50) have been omitted.
- E. Slide both Guide Rods (52) through Rubber Donuts (35) and Weight Stack Risers (50) and into Base Frame (A). If Weight Stack Risers (50) have been omitted, slide both Guide Rods (52) through Rubber Donuts (35) and into Base Frame (A).
- F. Slide Weight Stack Plates (57) onto Guide Rods (52) one at a time.
- G. Connect Selector Bar (53) to Top Plate (51) using:
One 11 (3/8" x 1 3/4" allen head bolt)
One 22 (3/8" spring washer)
- H. Thread Pulley Holder (54) into Selector Bar (53) a minimum of 1/2" using:
One 15 (1/2" nut)
One 23 (1/2" spring washer)
- I. Slide Pulley (25) into Pulley Holder (54) and secure using:
One 5 (M10x45 hex head bolt)
Two 19 (M10 washer)
One 13 (M10 nylon nut)
- J. Slide the Top Plate Assembly just constructed onto Guide Rods (52).
- K. Slide Shaft Collars (32) onto Guide Rods (52).
- L. Bring Guide Rods (52) toward the pre-drilled holes on Top Frame (B) and secure by pushing Shaft Collar (32) upwards into the hole. Turn to lock Shaft Collars (32) in place then secure by tightening M8x8 Allen Screws (10). Make sure Guide Rods (52) are completely secured.
- M. Connect Weight Stack Pin (7) to Weight Stack Pin Lanyard (38) and then secure Weight Stack Pin (7) to Weight Stack (57) at any position.
- N. Apply Weight Stack Stickers (44) onto Weight Stack (57) as shown in the diagram starting with the application of sticker 1 onto Top Plate (51).

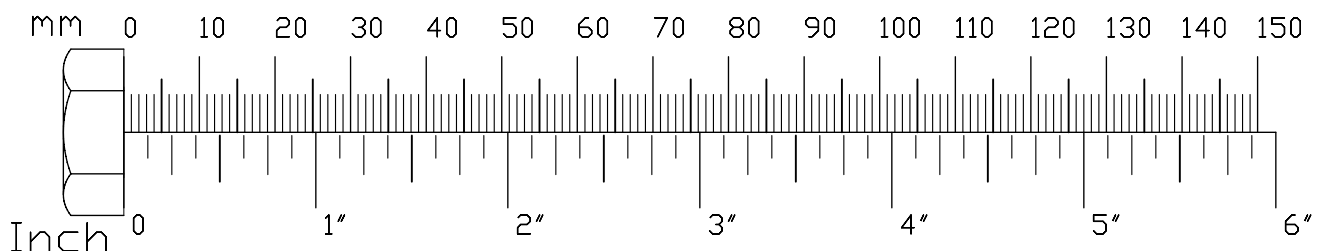

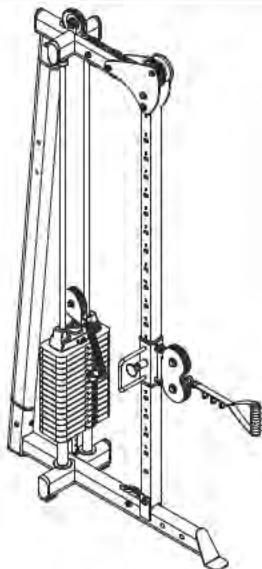

Above shows Step 3 assembled and completed.

- ☞ For 260 lb Weight Use Weight Stack Risers (50).
- ☞ For 310 lb Weight Use Omit Weight Stack Risers (50).

! WARNING !

Pulley Holder (54) must be threaded a minimum of 1/2" into the Selector Rod (53), and Jam Nut (15) tightened securely against Spring Lock Washer (23) to ensure proper connection. Check Jam Nut (15) once a week to make sure it is tight.

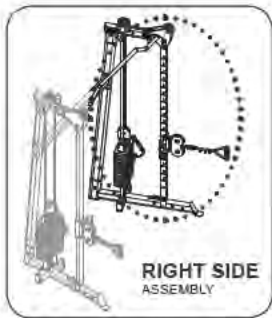
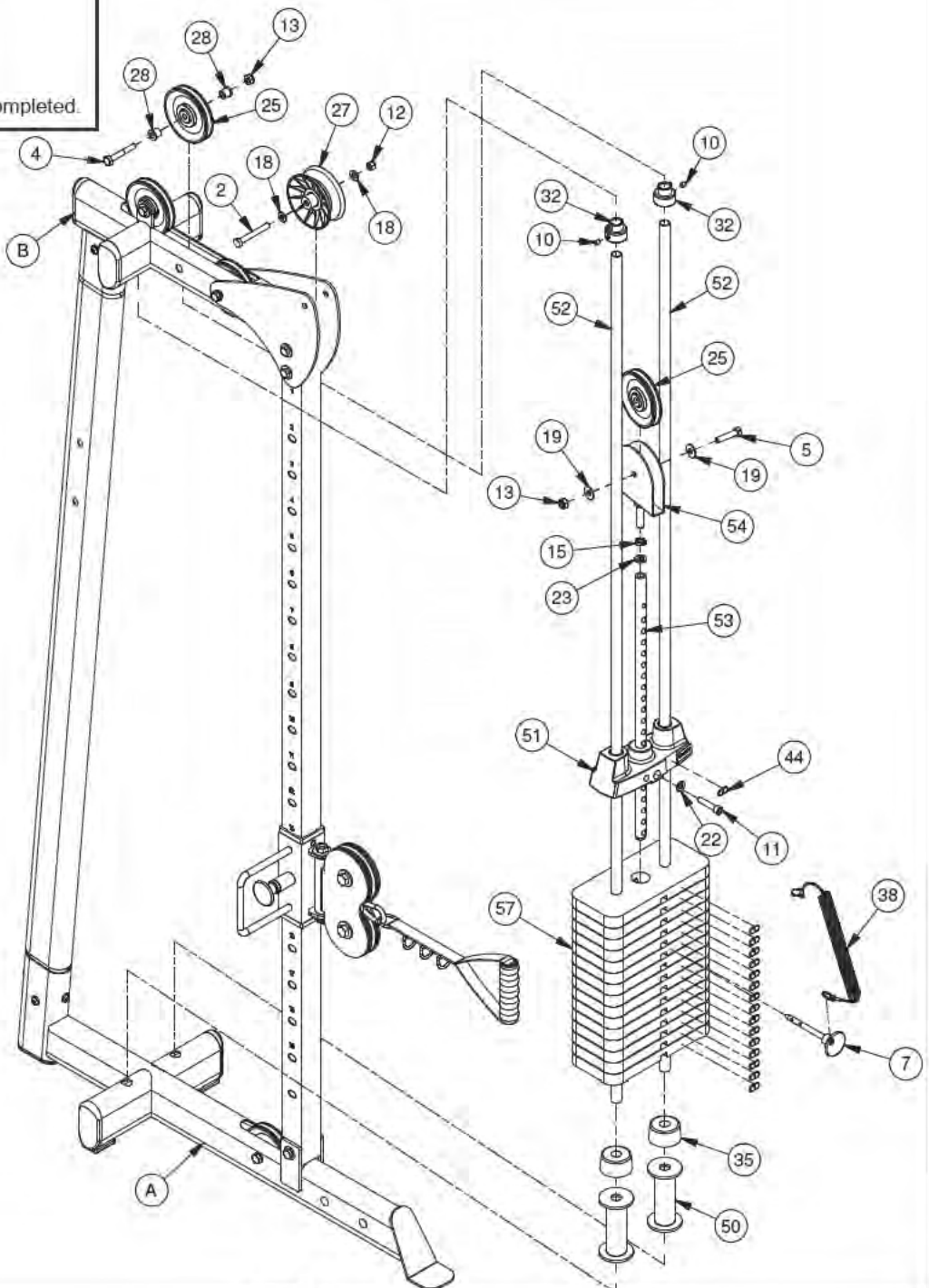

RIGHT SIDE ASSEMBLY

STEP**4**

Be careful to assemble all components in the sequence they are presented.

Finger tighten all hardware in this step unless otherwise noted.

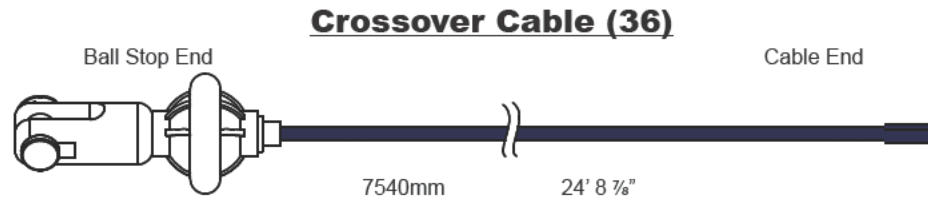
RIGHT SIDE ASSEMBLY

- A. Route the Cable End of Crossover Cable (36) from Pulley #1 up towards Pulley #2.
- B. Bring Crossover Cable (36) around Pulley #2, towards Pulley #3, then down towards Pulley #4.
- C. Route Crossover Cable (36) around Pulley #4, towards Pulley #5.
- D. Bring Crossover Cable (36) around Pulley #5 and Pulley #6, then down towards Pulley #7.
- E. Route Crossover Cable (36) around Pulley #7 and terminate on Handle (D) as shown in the diagram.

NOTE: Crossover Cable (36) needs to be stripped, using a knife, before inserting it into the slot on Handle (D).

- F. Once Crossover Cable (36) is stripped and inserted into Handle (D), wrench tighten the three M8x8 Allen Screws (10) to secure Crossover Cable (36).

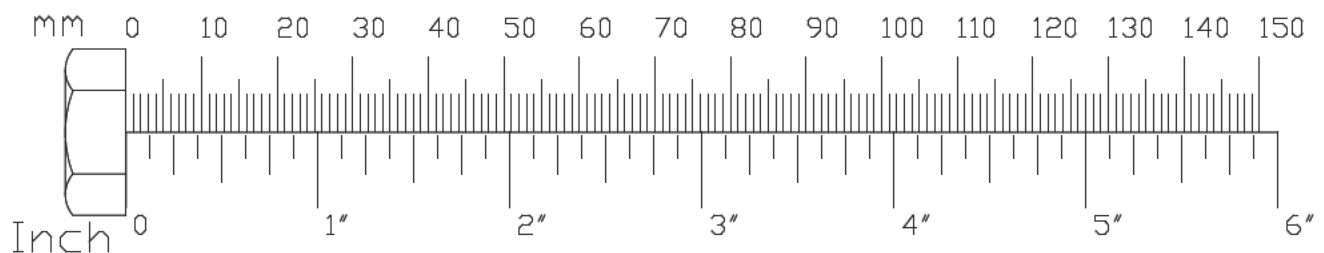

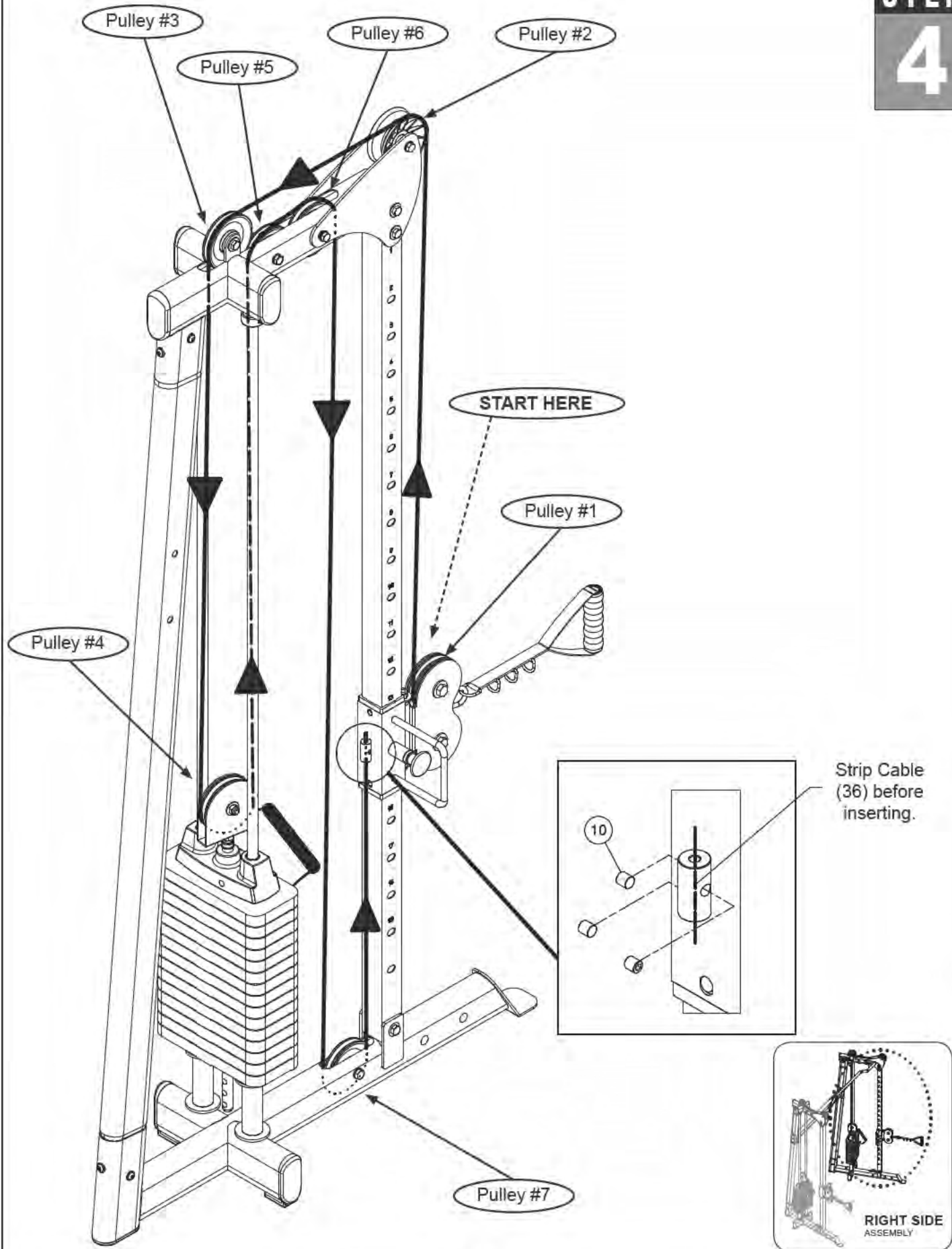

STEP**5**

Be careful to assemble all components in the sequence they are presented.

Finger tighten all hardware in this step unless otherwise noted.

LEFT SIDE ASSEMBLY

Crossover Cable (36)

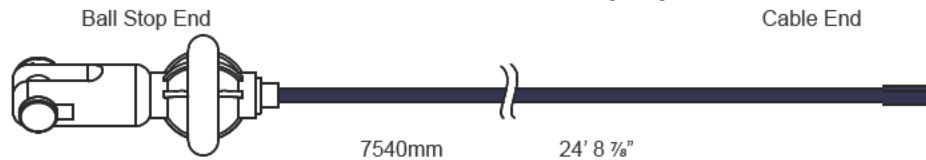

- A. Insert both Foot Caps (34) into Base Frame (A).
- B. Insert End Cap (46) into Base Frame (A).
- C. Insert four Round End Caps (45) into Base Frame (A).
- D. Slide Guide Post (G) into Base Frame (A) and secure using:
One 3 (M10x75 hex head bolt)
Two 19 (M10 washer)
One 13 (M10 nylon nut)
- E. Insert both Nylon Bushings (31) into Handle (D).
- F. Slide Handle (D) onto Guide Post (G) noting the direction of the Pop Pin on Handle (D) aligns with the pre-punched holes on Guide Post (G).
 NOTE: Make sure both Nylon Bushings (31) fit securely into Handle (D).
 Silicone Oil may be used to lubricate Guide Post (D) to ease Handle (D) installation.
- G. Insert Lower Pulley (26) into Double Pulley Holder (55) and secure using:
One 1 (1/2" x 50mm hex head bolt)
Two 17 (1/2" washer)
One 14 (1/2" nylon nut)
- H. Install Upper Pulley (26) and the Cable End of Crossover Cable (36) to Double Pulley Holder (55) as shown using:
One 1 (1/2" x 50mm hex head bolt)
Two 17 (1/2" washer)
One 14 (1/2" nylon nut)
 NOTE: Let Crossover Cable (36) hang.
 This will speed up the assembly process in later steps.
- I. Insert Pulley (25) into Base Frame (A) and secure using:
One 4 (M10x65 hex head bolt)
Two 28 (steel bushing)
One 13 (M10 nylon nut)
- J. Connect Handle (39) to Snap Link (30), then attach Snap Link (30) to the Ball Stop End of Crossover Cable (36) as shown in the diagram.

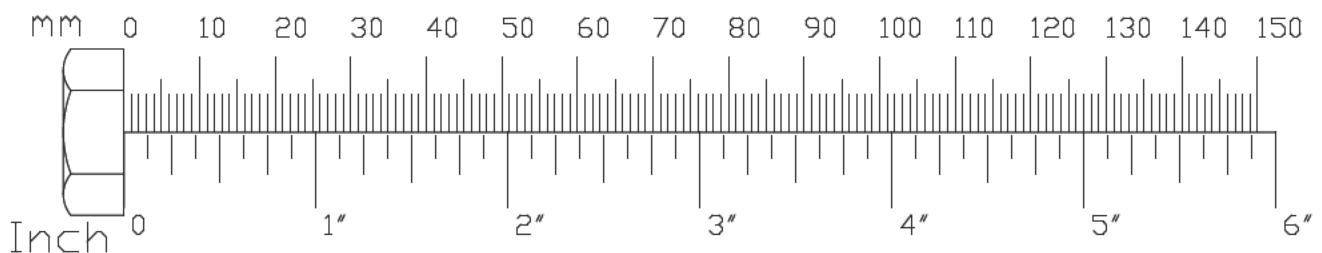

STEP
5

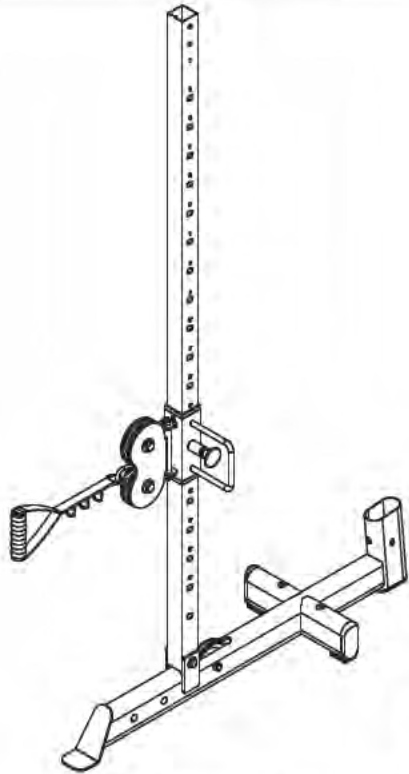

Above shows Step 5 assembled and completed.

Insert
Crossover Cable
(36) before installing Upper
Pulley (26).

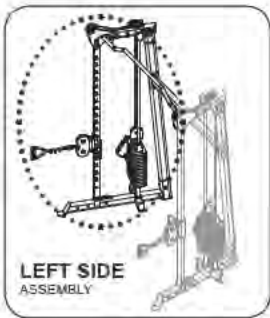
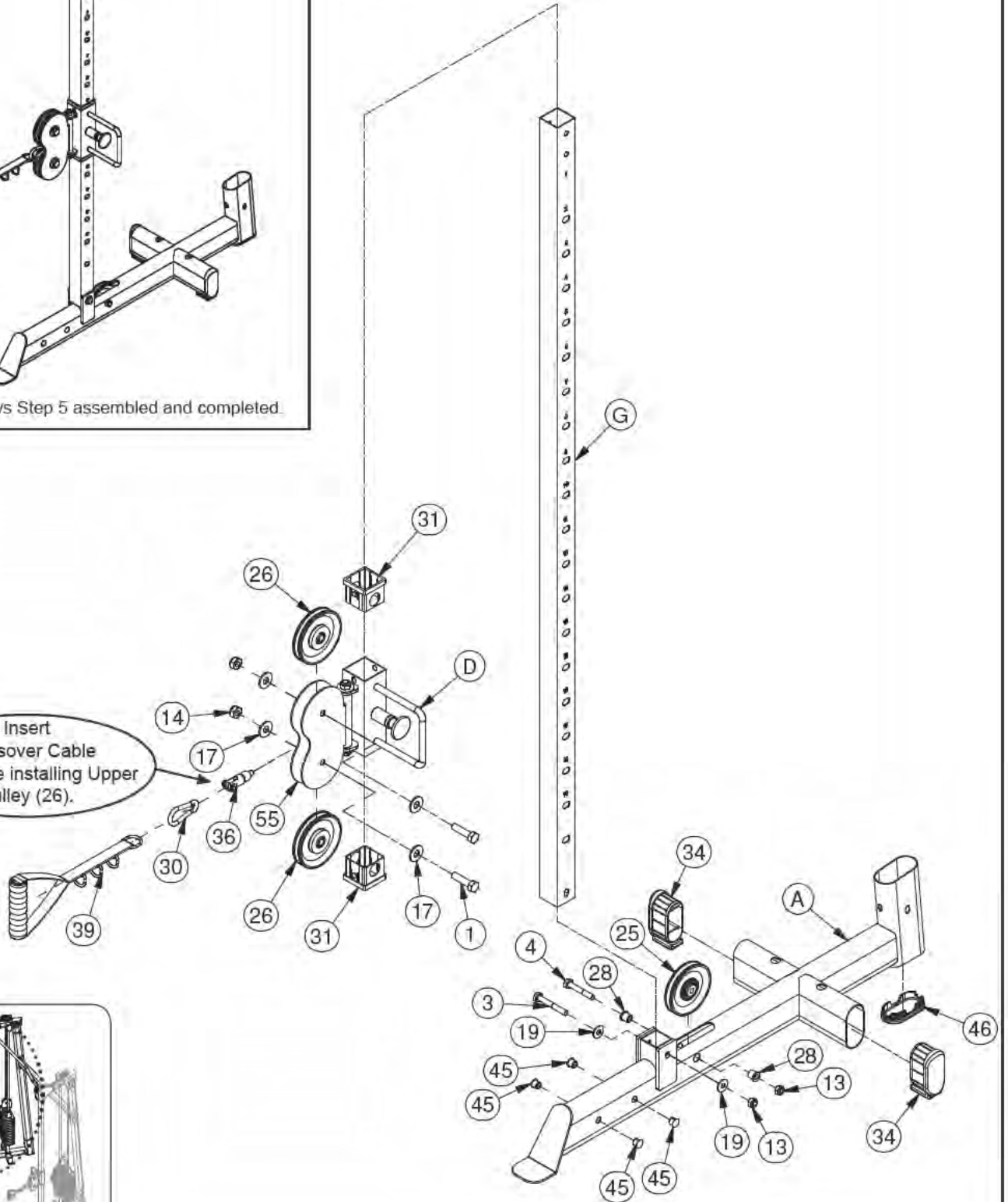

LEFT SIDE
ASSEMBLY

STEP**6**

Be careful to assemble all components in the sequence they are presented.

Finger tighten all hardware in this step unless otherwise noted.

LEFT SIDE ASSEMBLY

- A. Insert Upright Frame (F) into Base Frame (A) and secure using:
- Two 8 (M8x15 hex head bolt)
 - Two 9 (M8x20 hex head bolt)
 - Two 20 (M8 arc washer)
 - Two 21 (M8 washer)

NOTE: Pay special attention to the orientation of Upright Frame (F) as shown in the diagram. Make sure the pre-drilled holes are positioned closest to Top Frame (B).

- B. Insert three End Caps (33) into Top Frame (B) as shown.
- C. Connect Pulley #3 (25) to Top Frame (B) using:
- One 5 (M10x45 hex head bolt)
 - Two 19 (M10 washer)
 - One 13 (M10 nylon nut)
- D. Connect Pulley #6 (25) to Top Frame (B) and secure using:
- One 6 (M10x85 hex head bolt)
 - One 37 (steel bushing)
 - One 29 (steel bushing)
 - One 13 (M10 nylon nut)
- E. Place Top Frame (B) onto Upright Frame (F) and Guide Post (G) and secure using:
- Two 9 (M8x20 hex head bolt)
 - Two 8 (M8x15 hex head bolt)
 - Two 21 (M8 washer)
 - Two 20 (M8 arc washer)
 - Two 6 (M10x80 hex head bolt)
 - Four 19 (M10 washer)
 - Two 13 (M10 nylon nut)

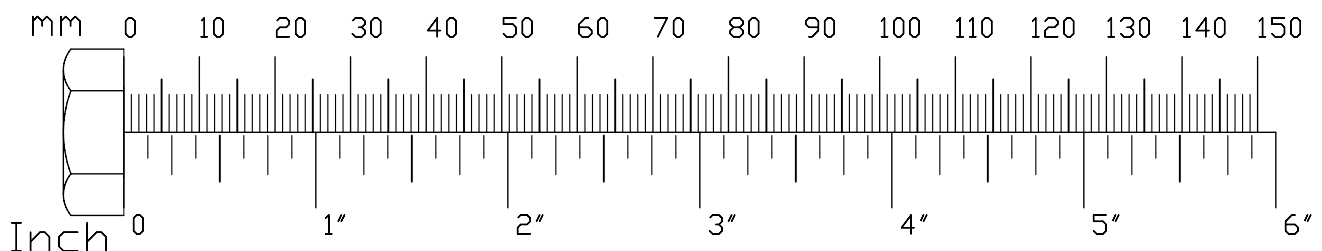

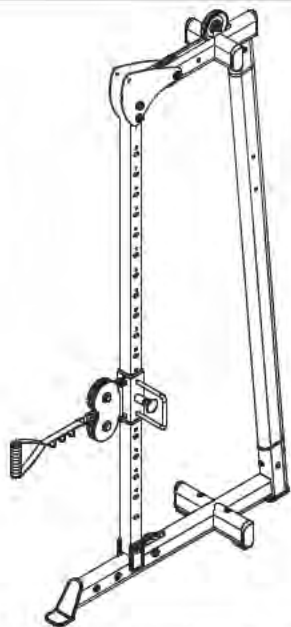

Above shows Step 6 assembled and completed.

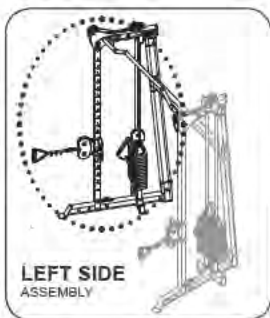
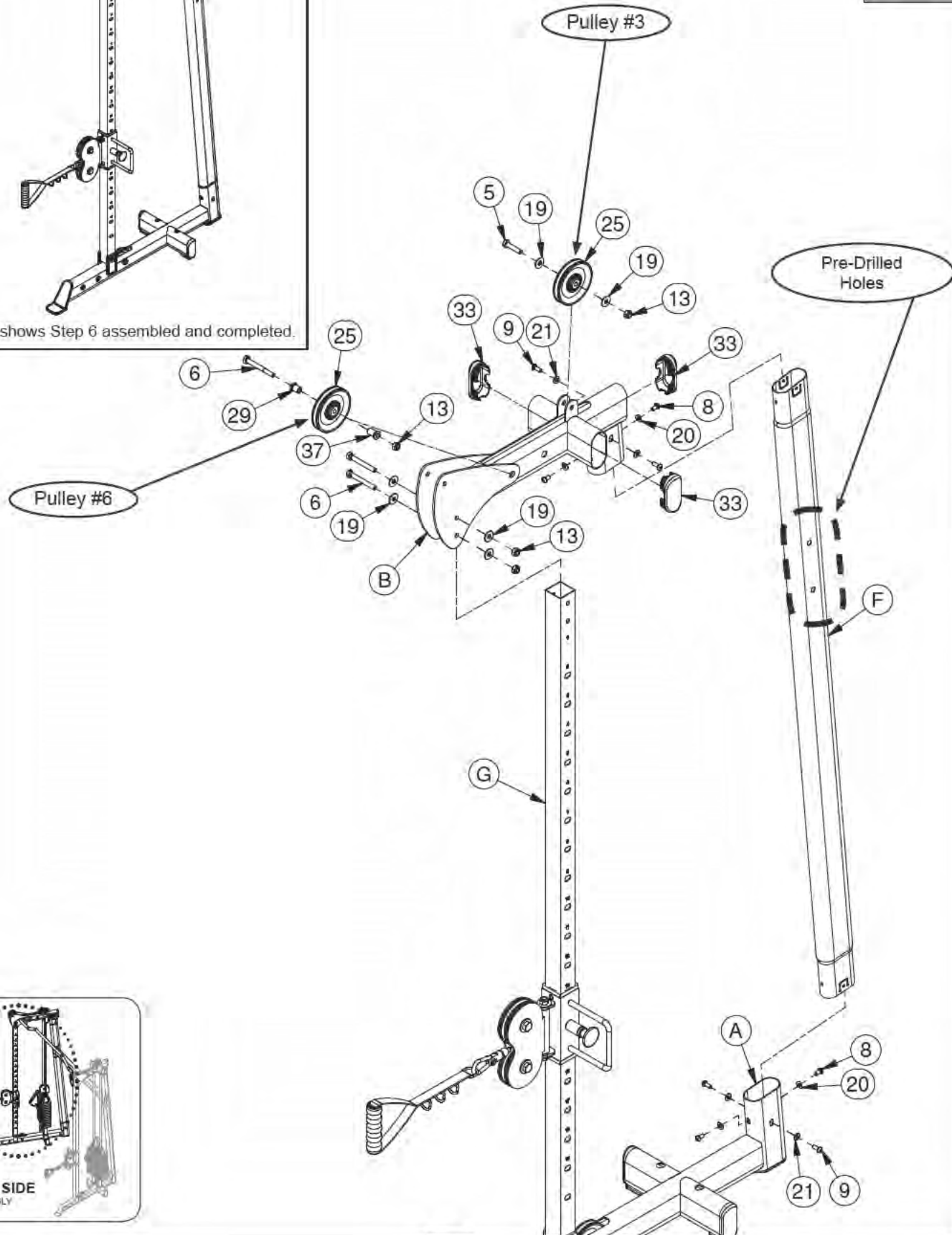

STEP**7**

Be careful to assemble all components in the sequence they are presented.

Finger tighten all hardware in this step unless otherwise noted.

LEFT SIDE ASSEMBLY

- A. Insert Pulley (25) into Top Frame (B) and secure using:
One 4 (M10x65 hex head bolt)
One 13 (M10 nylon nut)
Two 28 (steel bushing)
- B. Insert Pulley (27) into Top Frame (B) and secure using:
One 2 (3/8" x 3" hex head bolt)
Two 18 (3/8" washer)
One 12 (3/8" nylon nut)
- C. Place both Weight Stack Risers (50) onto Base Frame (A) as shown in the diagram.
NOTE: Weight Stack Risers are omitted when using the upgrade 310 Lb Weight Stack.
- D. Place a Rubber Donut (35) onto each Weight Stack Riser (50) or onto Base Frame (A) if Weight Stack Risers (50) have been omitted.
- E. Slide both Guide Rods (52) through Rubber Donuts (35) and Weight Stack Risers (50) and into Base Frame (A). If Weight Stack Risers (50) have been omitted, slide both Guide Rods (52) through Rubber Donuts (35) and into Base Frame (A).
- F. Slide Weight Stack Plates (57) onto Guide Rods (52) one at a time.
- G. Connect Selector Bar (53) to Top Plate (51) using:
One 11 (3/8" x 1 3/4" allen head bolt)
One 22 (3/8" spring washer)
- H. Thread Pulley Holder (54) into Selector Bar (53) a minimum of 1/2" using:
One 15 (1/2" nut)
One 23 (1/2" spring washer)
- I. Slide Pulley (25) into Pulley Holder (54) and secure using:
One 5 (M10x45 hex head bolt)
Two 19 (M10 washer)
One 13 (M10 nylon nut)
- J. Slide the Top Plate Assembly just constructed onto Guide Rods (52).
- K. Slide Shaft Collars (32) onto Guide Rods (52).
- L. Bring Guide Rods (52) toward the pre-drilled holes on Top Frame (B) and secure by pushing Shaft Collar (32) upwards into the hole. Turn to lock Shaft Collars (32) in place then secure by tightening M8x8 Allen Screws (10). Make sure Guide Rods (52) are completely secured.
- M. Connect Weight Stack Pin (7) to Weight Stack Pin Lanyard (38) and then secure Weight Stack Pin (7) to Weight Stack (57) at any position.
- N. Apply Weight Stack Stickers (44) onto Weight Stack (57) as shown in the diagram starting with the application of sticker 1 onto Top Plate (51).

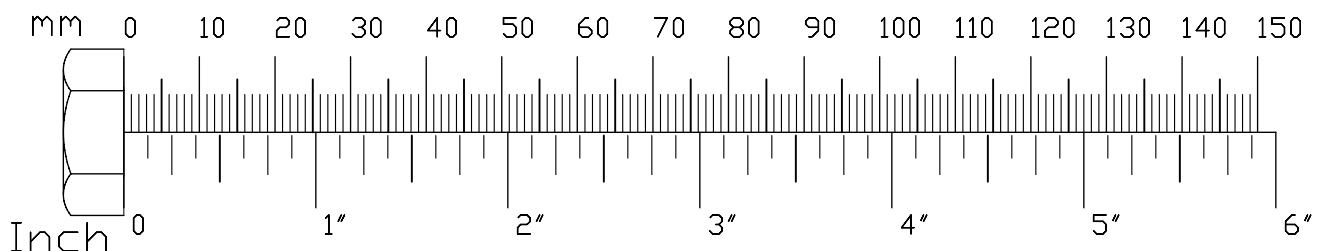

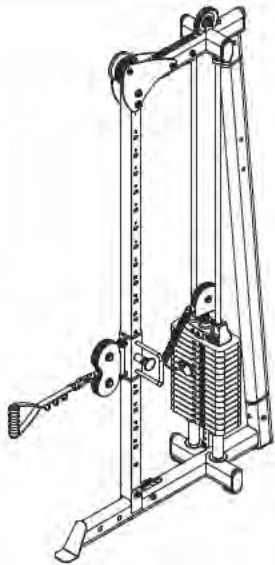

Above shows Step 7 assembled and completed.

- ☞ For 260 lb Weight Use Weight Stack Risers (50).
- ☞ For 310 lb Weight Use Omit Weight Stack Risers (50).

! WARNING !

Pulley Holder (54) must be threaded a minimum of 1/2" into the Selector Rod (53), and Jam Nut (15) tightened securely against Spring Lock Washer (23) to ensure proper connection. Check Jam Nut (15) once a week to make sure it is tight.

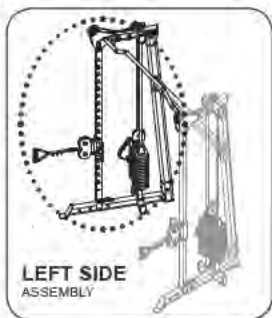
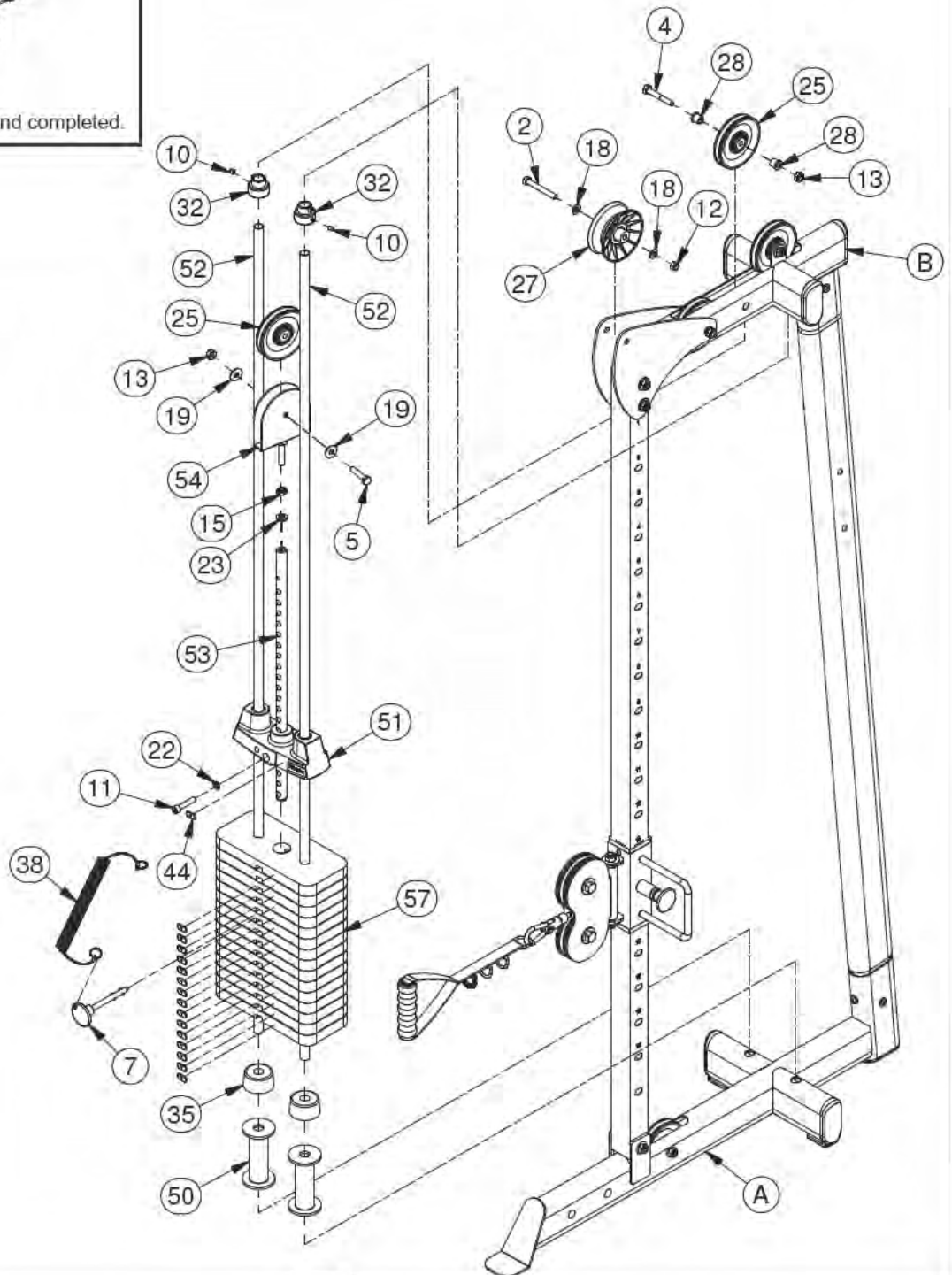

STEP**8**

Be careful to assemble all components in the sequence they are presented.

Finger tighten all hardware in this step unless otherwise noted.

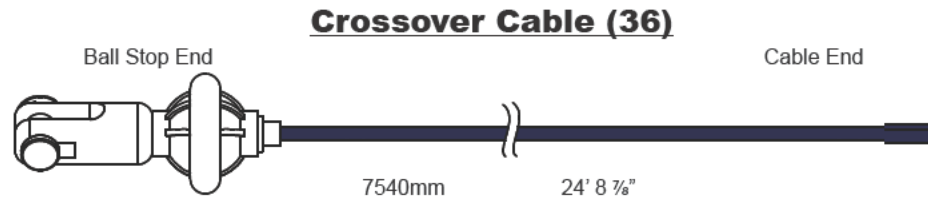
LEFT SIDE ASSEMBLY

- A. Route the Cable End of Crossover Cable (36) from Pulley #1 up towards Pulley #2.
- B. Bring Crossover Cable (36) around Pulley #2, towards Pulley #3, then down towards Pulley #4.
- C. Route Crossover Cable (36) around Pulley #4, towards Pulley #5.
- D. Bring Crossover Cable (36) around Pulley #5 and Pulley #6, then down towards Pulley #7.
- E. Route Crossover Cable (36) around Pulley #7 and terminate on Handle (D) as shown in the diagram.

NOTE: Crossover Cable (36) needs to be stripped, using a knife, before inserting it into the slot on Handle (D).

- F. Once Crossover Cable (36) is stripped and inserted into Handle (D), wrench tighten the three M8x8 Allen Screws (10) to secure Crossover Cable (36).

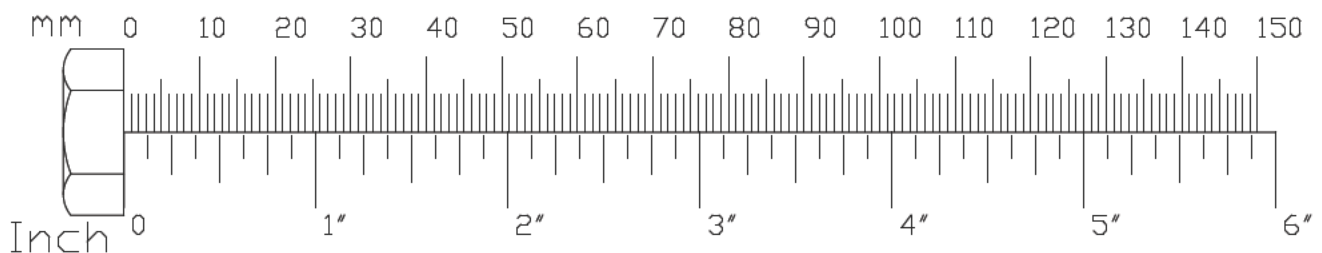

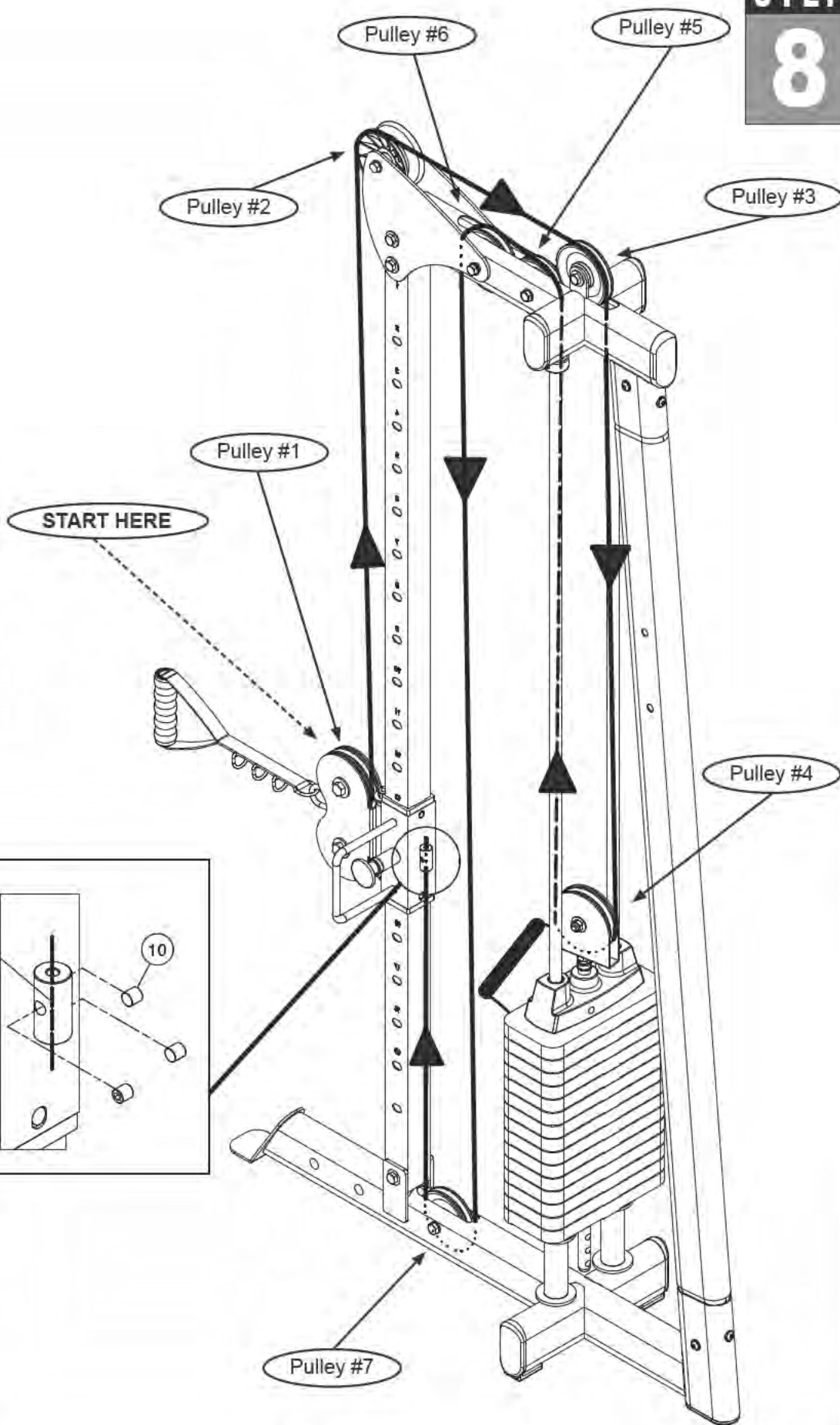

Strip Cable (36) before inserting.

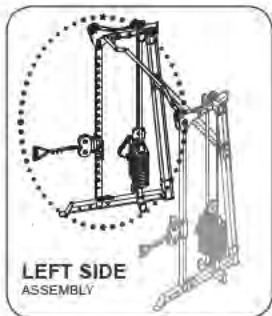
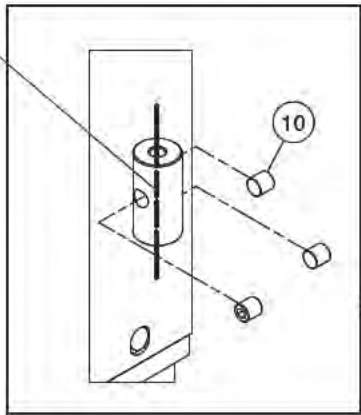

STEP**9**

Be careful to assemble all components in the sequence they are presented.

Finger tighten all hardware in this step unless otherwise noted.

- A. Face the Left Side and Right Side of the GDCC210 towards each other as shown in the diagram.

NOTE: Certain hardware may need to be removed to complete this installation.
The hardware was pre-installed to aid with finalizing the assembly.

- B. Connect Cross Frame (E) and Flat Plate (H) to both the Left Side Upright Frame (F) and the Right Side Upright Frame (F) using:
Four 3 (M10x75 hex head bolt)
Eight 19 (M10 washer)
Four 13 (M10 nylon nut)

- C. Remove the following pre-installed hardware in order to install Pull Up Bar (C):
Six 6 (M10x80 hex head bolt)
Eight 19 (M10 washer)
Six 13 (M10 nylon nut)
Two 37 (26.5mm steel bushing)
Two 29 (21.5mm steel bushing)

- D. Install Pull Up Bar (C) onto Top Frame (B) and secure using:
Six 6 (M10x80 hex head bolt)
Eight 19 (M10 washer)
Six 13 (M10 nylon nut)
Two 37 (26.5mm steel bushing)
Two 29 (21.5mm steel bushing)

- E. Now you may wrench tighten all hardware on the unit.

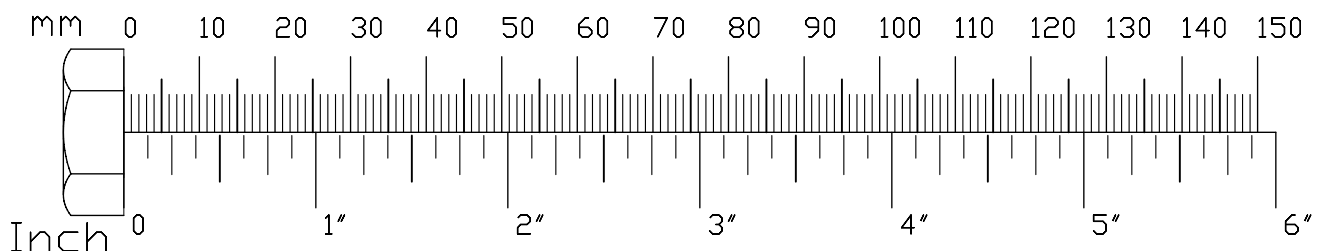

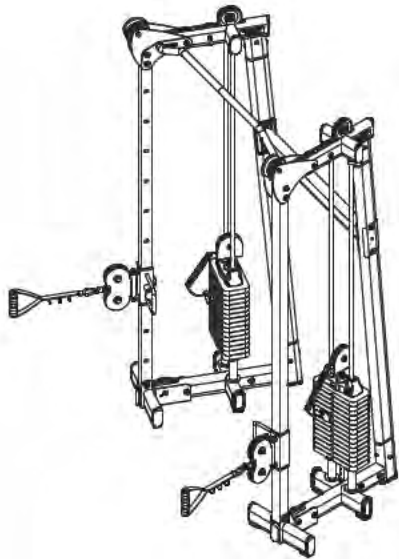

Above shows Step 9 assembled and completed.

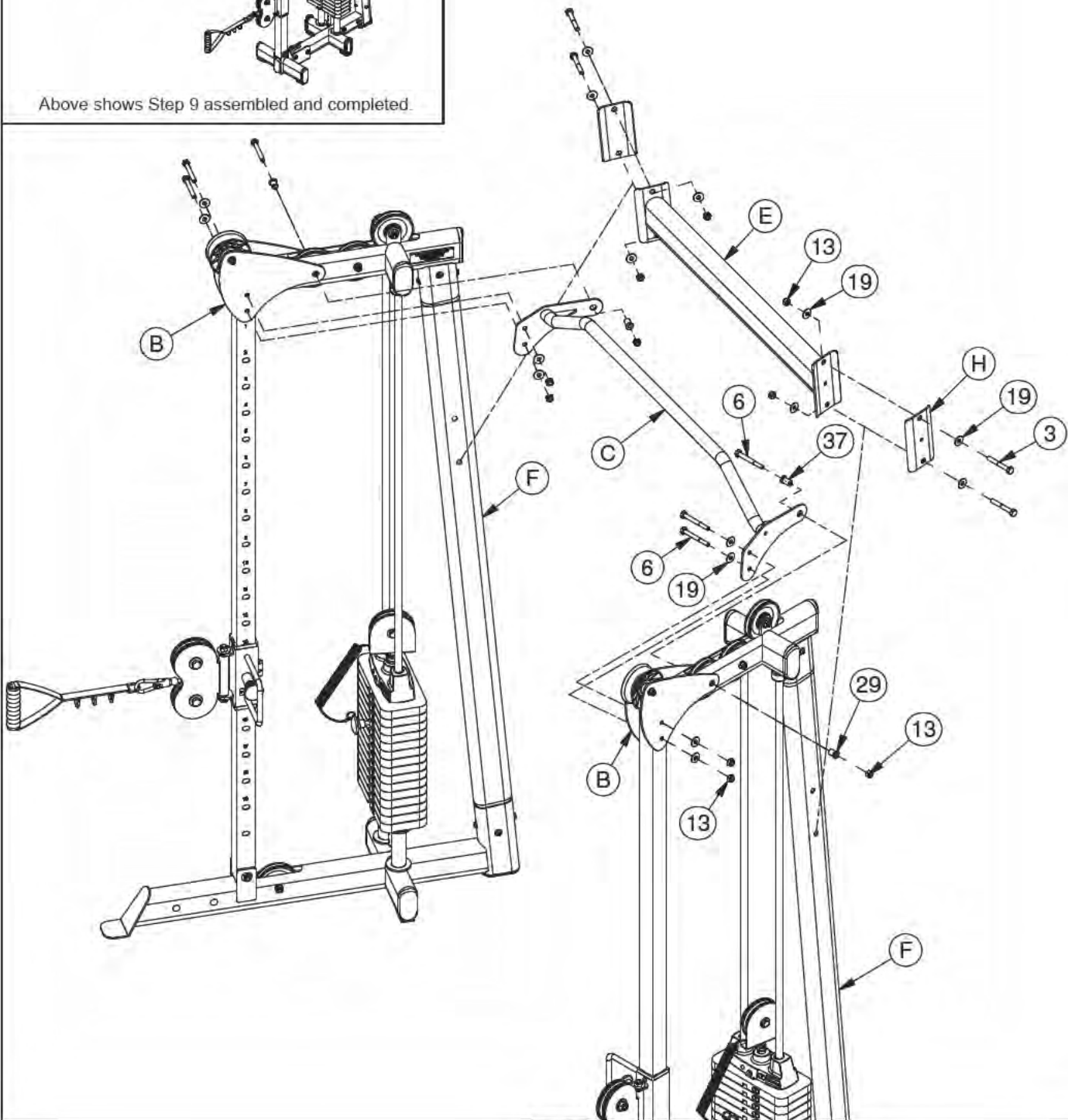

Accessory Installation

The GDCC210 comes equipped with 2 accessories:

- 1) Handle Strap
- 2) Ankle Strap

The diagrams on the following page show the proper installation of the above accessories. Use the provided Snap Links to properly connect the accessories to your BodySolid gym.

The GDCC210 workout poster included with your machine is installed on the side of Upright Frame (F) as shown.

Simply peel off the sticker cover on Poster Clips (48) and place the evenly spaced Poster Clips (48) onto Upright Frame (F).

Finally, insert Poster (49) onto Poster Clips (48).

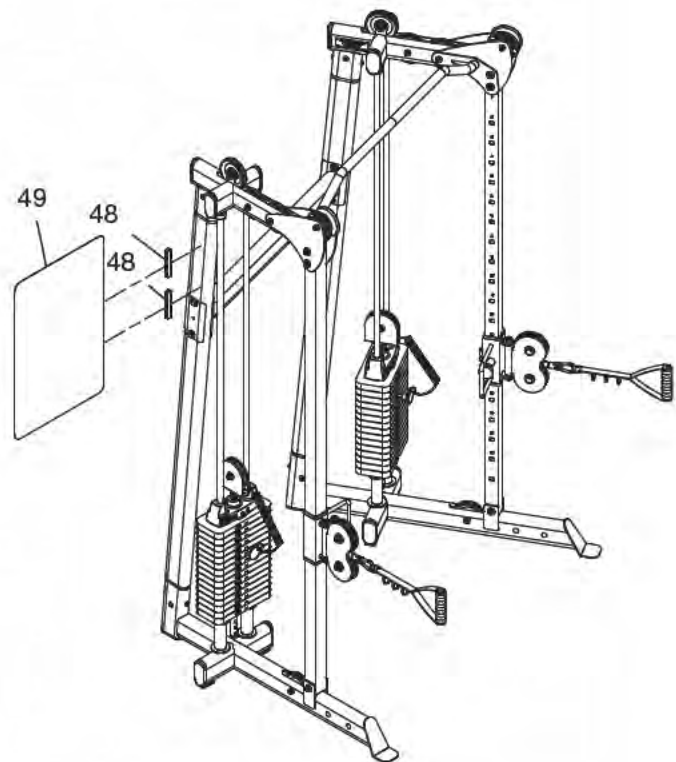

Congratulations! You are done. After assembly, you should check all functions to ensure correct operation. If you experience problems, first recheck the assembly instructions to locate any possible errors made during assembly. If you are unable to correct the problem, call the dealer from whom you purchased the machine or call 1-800-556-3113 for the dealer nearest you.

NOTE: If any bolts seem to loosen periodically, use Loctite 242 for a long-term cure.

This gym is capable of a variety of different exercises, as well as, smooth and user-friendly adjustment features. The following page of adjustments will help you to familiarize yourself with your new gym. We hope you are completely satisfied with this product and wish you many years of enjoyment.

Accessories

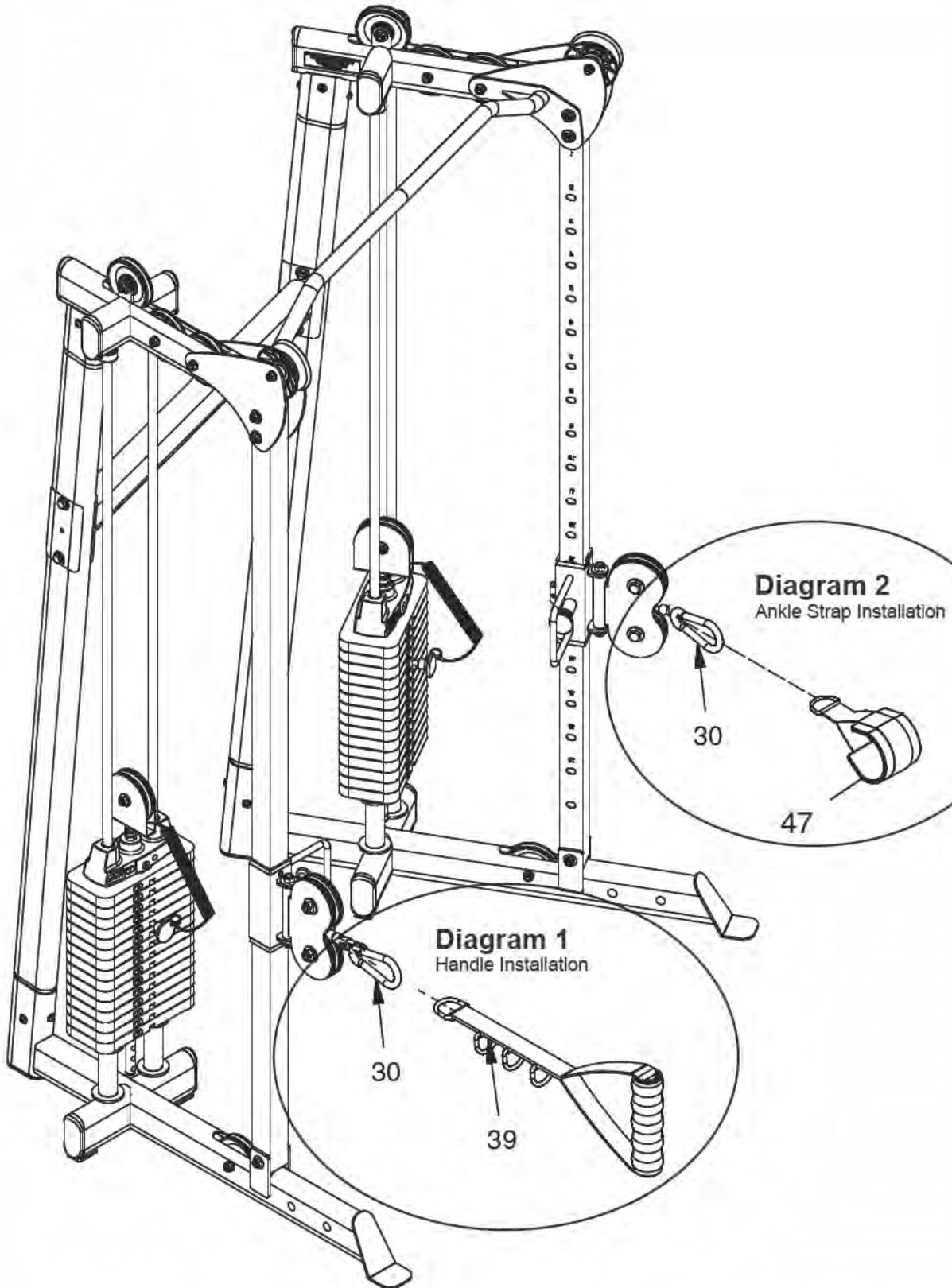

Warning, Safety & Maintenance

Be sure that all users carefully read and understand all warning, safety and maintenance labels on the machine before each use. Failure to do so may result in death or serious injury.

It is imperative that you retain this Owner's Manual and be sure all warning labels are legible and intact. Replacement Owner's Manuals and warning labels are available from your local Body-Solid dealer.

If you have any questions about the operation, set up or maintenance of this machine please call our customer service department at 1 (800) 556-3113.

THERE IS A RISK ASSUMED BY INDIVIDUALS WHO USE THIS TYPE OF EQUIPMENT. TO MINIMIZE RISK, YOU MUST FOLLOW THESE RULES:

1. Inspect equipment before each workout. Check that all nuts, bolts, screws and pop pins are in place and fully tightened. Also, before use, check cables for signs of wear. Replace all worn parts immediately. Never use machine if any parts are damaged or missing. **FAILURE TO FOLLOW THESE RULES MAY RESULT IN SERIOUS INJURY.**
2. Keep clear of the cables and all moving parts when the machine is in use.
3. Always make sure all Snap Links are closed when doing any cable/pulley/strap exercises.
4. Exercise with care. Perform your exercises at a smooth moderate pace; never perform jerky or uncoordinated movements that may cause injury.
5. It is recommended that you should workout with a training partner.
6. Do not allow children or minors to play on or around this equipment.
7. If unsure of proper use of equipment, call your local Body-Solid distributor or the Body-Solid customer service department at 1-800-556-3113.
8. **WARNING:** Consult your physician before starting your exercise program. For your own safety, do not begin any exercise program without proper instruction. RAL8-6-03 WC-54

Warning Label for Rules

MAINTENANCE SCHEDULE		D	W
		A	E
		I	E
		L	K
		Y	L
		Y	L
Cables:	Check tension, end fittings, and coating	✓	
	Check that locking nut at weight stack is tight		✓
Upholstery:	Wipe down and dry	✓	
	Clean and condition		✓
Frame:	Wipe down and dry	✓	
	Polish / Wax		✓
Chrome:	Wipe down and dry	✓	
	Polish / Lubricate		✓
Nuts / Bolts / Fasteners:	Tighten and / or adjust as needed		✓
Guide Rods:	Lubricate and clean		✓
Linear Rods:	Lubricate and clean		✓
Seat Sleeves:	Lubricate and clean		✓
Adjustments / Locking Pins / Tightening Knobs			✓
Weight Stack Pins			✓
Warning Instruction Labels			✓
Springs / Pop Pins		✓	
Anti Skid Surfaces			✓
Hand Grips / Rollers			✓

For Body-Solid Customer Service
Call 1-800-556-3113
#MSSTKR0303

Warning Label for Maintenance

⚠ **DANGER** ⚠

MAXIMUM 1 USER AT A TIME

Usage by two or more users is not permitted at any time. Death or serious injuries will result with improper exercise. Use only the weight stack supplied by the manufacturer. **DO NOT** add additional resistance, unauthorized accessories or attachments to the machine. Never pin the weight stack or top plate into an elevated position.

Warning, Safety & Maintenance

Although Body-Solid provides the highest quality of materials and workmanship in its products, the fact remains that component parts eventually wear out over time and with use. **This is particularly true with reference to pliable moving parts such as cables.** In spite of any expressed and/or implied warranties, intervening factors such as improper use, unusually heavy use, improper installation, improper alignment, poor maintenance, etc. serve to drastically reduce the usable life and safety of cables.

Be advised that dangerous conditions can arise even during warranty periods and that any expressed and/or implied warranties **Do Not Negate** the owner's responsibility to thoroughly, carefully and daily inspect all cables on this machine.

Serious injury can occur if you are struck by falling weights or moving parts. The risk that you assume by using this type of equipment can be reduced by following a few simple steps:

Cable inspection should be performed daily. Inspect all cables, the nylon coating on all cables and the area near the fittings at each end of each cable. **Replace any damaged or worn cables immediately.** Do not allow the machine to be used until damaged or worn cables are replaced.

Important: Cables are wear items. It is your responsibility to prevent unexpected breakage. The actual wire strands, the fittings and the nylon coating itself must all be scrutinized. Using or allowing a machine to be used with a suspect cable can result in death or serious injury.

The nylon coating on a cable is essential for cable life and safety. Visually inspect all cables and pulleys. Look at the cables as they travel around the cams and pulleys. A cable that is wearing may exhibit a "ballooned" or broken coating in the area that passes over the pulley. Damage to the coating is an early warning signal. A cable should be replaced if the nylon coating is missing, is damaged in anyway, has pulled or shrunk from the fittings at the end of the cables, or if it is discolored. Discoloration of the cable coating is an early indication of internal problems such as wear or fraying.

Annual cable replacement (semiannual in multi-user settings) is strongly recommended as an additional precaution. The rate at which cables wear depends on many factors including: number of users, number of repetitions, weight setting, misuse, abuse, etc. Because of this, periodic cable replacement is not a sufficient safeguard against unexpected breakage.

Nothing short of a thorough, careful, daily inspection constitutes an adequate safety program.

WARNING

Safety and Maintenance of Cables

IMPORTANT: Cables are wear items. It is your responsibility to prevent unexpected breakage. **Cable inspection should be performed daily.** Inspect all cables, the nylon coating on all cables, and the area near the fitting at each end of each cable. **Replace any damaged or worn cable immediately.** Do not allow the machine to be used until damaged or worn cables are replaced. Using or allowing a machine to be used with a suspect cable can result in serious injury. See Owner's Manual for more information.

For Body-Solid Customer Service
Call 1-800-556-3113

Warning, Safety & Maintenance

Precision craftsmanship assures Body-Solid's ability to consistently deliver products of the highest standards. Our products have been carefully designed to ensure safe, efficient long term operation.

However, it must be realized that safe use of this equipment requires that owners carefully read and follow the Body-Solid use recommendations, warnings, and maintenance guidelines in this Owners Manual.

Routine inspection and maintenance is of critical importance to ensure maximum safety and performance. Body-Solid uses the highest quality materials available, but wear is inevitable. Therefore, you must carefully inspect your equipment as outlined in the Maintenance Schedule.

Be advised that dangerous conditions can arise even during a warranty period. A warranty does not negate the owner's responsibility to thoroughly, carefully and daily inspect the machine.

Including maintaining the equipment, the owner's responsibility is also to:

- Be sure to always provide adequate supervision to all end-users.
- Be sure to instruct all end-users of proper usage.
- Be sure all supervisors and personal trainers who instruct end-users on equipment use are properly trained and know the function and importance of every adjustment and setting. Also, be sure these trainers provide proper instruction to end-users on the fundamentals of strength training.

CABLES:

- While the machine is not in use, carefully run your fingers along the cable to feel for thinning or bulging areas. Replace cables immediately at the first sign of damage or wear. Do not use equipment until damaged cable has been replaced.
- Visually inspect the cables for fraying, cracking, peeling or discoloration.
- Check slack in cables and re-adjust cable tension if needed.
- Check that the jam nut on the selector rod top bolt is tight.

UPHOLSTERY:

- Wipe down after every workout.
- Periodically take the time to use a mild soap or a mild vinyl upholstery cleaner. Avoid using any abrasive cleaner not intended for use on vinyl.
- Keep sharp or pointed objects out of your pockets and clear of all upholstery.

NUTS/BOLTS/FASTENERS:

- Periodically inspect all nuts and bolts. Tighten if needed. If bolts seem to loosen periodically, use Loctite 242 for a long-term cure.
- Go through a re-tightening sequence periodically to ensure that all hardware is properly tensioned.

GUIDE RODS:

- Wipe clean with a dust free rag. Lubricate with a Silicon or Teflon based lubricant.

ADJUSTMENTS / LOCKING PINS /

TIGHTENING KNOBS:

- Check all pieces for signs of visible wear or damage.
- Check springs in Snap Links and Pop Pins for proper tension and alignment.
- If the spring sticks or has lost its rigidity, replace it immediately.

ANTI-SKID SURFACES:

- Replace if they appear worn or become slippery.

WARNING INSTRUCTION LABELS:

- Inspect and familiarize yourself with all safety warnings and other user information on decals.

Warning, Safety & Maintenance

MAINTENANCE SCHEDULE	DAILY	WEEKLY	LATEST DATE ENTRY						
CABLES: CHECK TENSION, END FITTINGS, AND COATING. CHECK THAT JAM NUT ON THE SELECTOR ROD TOP BOLT IS TIGHT.	✓								
UPHOLSTERY: WIPE DOWN AND DRY CLEAN AND CONDITION.	✓	✓							
FRAME: WIPE DOWN AND DRY POLISH/WAX	✓	✓							
CHROME: WIPE DOWN AND DRY POLISH/LUBRICATE	✓	✓							
NUTS/BOLTS/FASTENERS: TIGHTEN AND/OR ADJUST AS NEEDED		✓							
GUIDE RODS: LUBRICATE AND CLEAN		✓							
LINEAR RODS: LUBRICATE AND CLEAN		✓							
SEAT SLEEVES: LUBRICATE AND CLEAN		✓							
ADJUSTMENTS / LOCKING PINS / TIGHTENING KNOBS		✓							
WEIGHT STACK PINS		✓							
WARNING INSTRUCTION LABELS		✓							
SPRINGS / POP PINS	✓								
ANTI-SKID SURFACES		✓							
HAND GRIPS / ROLLERS		✓							
FOR BODY-SOLID CUSTOMER SERVICE: 1-800-556-3113		*Make several copies of this page to keep track of your maintenance. You can print more copies of this page by going to: http://www.bodysolid.com/support/docs.html							

Mainframe Parts List

Part#	Qty	Description
A	2	BASE FRAME
B	2	TOP FRAME
C	1	PULL UP BAR
D	2	HANDLE
E	1	CROSS FRAME
F	2	UPRIGHT FRAME
G	2	GUIDE POST
H	2	PLATE

Hardware List

1	4	HEX HEAD BOLT		1/2" x 50 mm	
2	2	HEX HEAD BOLT		3/8" x 3"	
3	6	HEX HEAD BOLT		M10x75	
4	4	HEX HEAD BOLT		M10x65	
5	4	HEX HEAD BOLT		M10x45	
6	6	HEX HEAD BOLT		M10x80	
7	2	WEIGHT STACK PIN			(8250-071)
8	8	HEX HEAD BOLT	- PREINSTALLED	M8x15	
9	8	HEX HEAD BOLT	- PREINSTALLED	M8x20	
10	10	ALLEN SCREW	- PREINSTALLED	M8x8	
11	2	ALLEN HEAD BOLT		3/8" x 1 3/4"	
12	2	NYLON NUT		3/8"	
13	20	NYLON NUT		M10	
14	4	NYLON NUT		1/2"	
15	2	NUT		1/2" x 13 mm	
16	4	NYLON NUT	- PREINSTALLED	M12	
17	8	WASHER		1/2" ID	
18	4	WASHER		3/8" ID	
19	28	WASHER		M10 ID	
20	8	ARC WASHER	- PREINSTALLED	M8	
21	8	WASHER	- PREINSTALLED	M8 ID	
22	2	SPRING WASHER		3/8"	
23	2	SPRING WASHER		1/2"	
24	4	WASHER	- PREINSTALLED	M12	
25	10	PULLEY		Φ110	(9213-002C)
26	4	PULLEY		Φ 4 1/2	(9213-010B)
27	2	PULLEY		Φ109	(9213-022A)
28	8	STEEL BUSHING		Φ16 x Φ10 x 16.5L	(8530-009)
29	2	STEEL BUSHING		Φ20 x Φ10 x 21.5L	(8530-010)
30	2	SNAP LINK		Φ8	(8810-001)

Part numbers are required when ordering parts.

Hardware List

Part#	Qty	Description		
31	4	NYLON BUSHING	M60x50	(9211-033)
32	4	SHAFT COLLAR	$\Phi \frac{3}{4}$ "	(9211-046)
33	6	END CAP		(9211-114)
34	4	FOOT CAP		(9211-117)
35	4	RUBBER DONUT	$\Phi 55$	(9310-027)
36	2	STEEL CABLE	7540 mm	
37	2	STEEL BUSHING	$\Phi 16 \times \Phi 10.2 \times 26.5L$	(8530-019)
38	2	WEIGHT STACK PIN LANYARD		(F920003)
39	2	HANDLE		(9630-125)
41	4	OILITE BUSHING - PREINSTALLED		(8520-001)
42	2	SHAFT - PREINSTALLED		(8260-068)
43	2	FLAT POP PIN - PREINSTALLED		(8250-065)
44	2	WEIGHT STACK STICKERS		(9440-047)
45	8	ROUND END CAP		(9211-061)
46	2	END CAP		(9211-138)
47	2	ANKLE STRAP		(50NAS2)
48	2	POSTER CLIPS		(9219-012)
49	1	GDCC210 POSTER		
50	4	WEIGHT STACK RISER		
51	2	TOP PLATE		
52	4	GUIDE ROD		
53	2	SELECTOR BAR		
54	2	PULLEY HOLDER		
55	2	DOUBLE PULLEY HOLDER		
57	30/40	WEIGHT STACK		
60	2	PINCH POINTS STICKER		(9440-117)
61	2	WARNING STICKER		(9440-103)
62	2	POP PIN STICKER		(9440-104)
63	2	GENERAL WARNING STICKER		(9440-105)
64	1	ALUMINUM LOGO		(9440-199)
65	2	CABLE WARNING STICKER		(9440-113)
66	1	BODYSOLID PLATE		(9440-028)
67	1	WARNING STICKER		(9440-253)

Part numbers are required when ordering parts.

Hardware (To Scale)

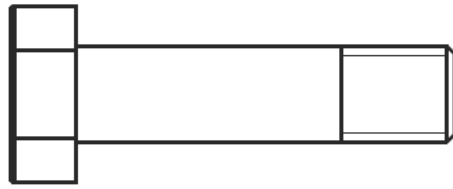

Part# 1

1/2" x 50mm

Hex Head Bolt

Qty. 4

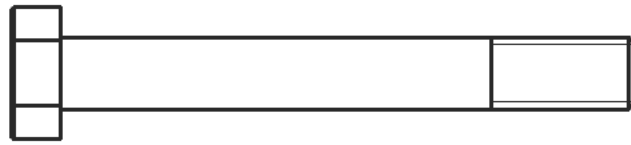

Part# 2

3/8" x 3"

Hex Head Bolt

Qty. 2

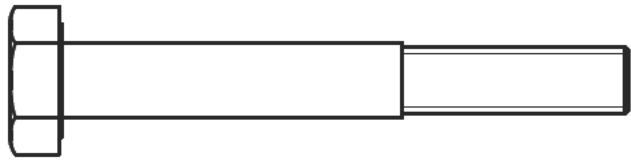

Part# 3

M10x75

Hex Head Bolt

Qty. 6

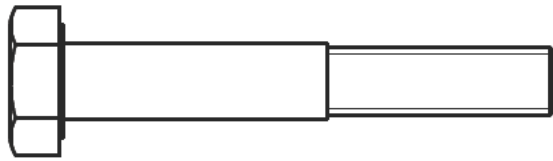

Part# 4

M10x65

Hex Head Bolt

Qty. 4

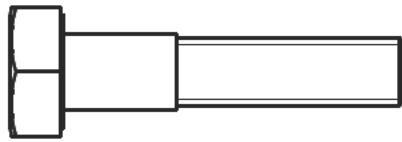

Part# 5

M10x45

Hex Head Bolt

Qty. 4



Part# 6

M10x80

Hex Head Bolt

Qty. 6

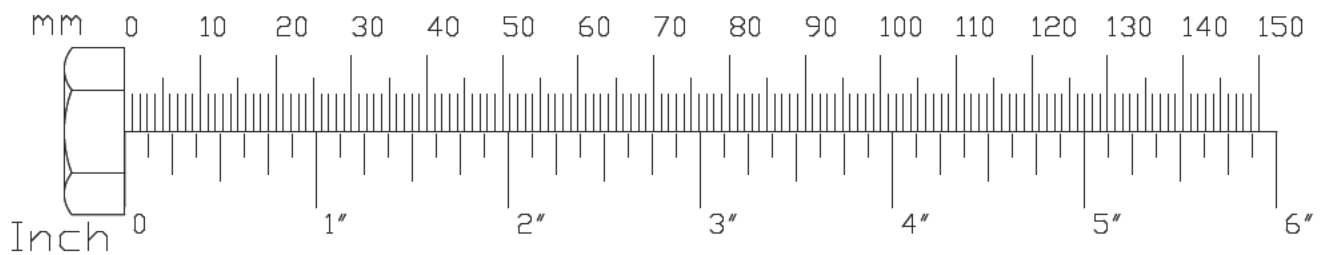

Hardware (To Scale)

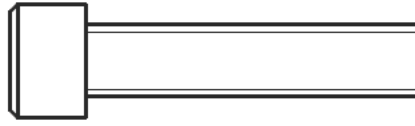

Part# 11

$\frac{3}{8}$ " x $1 \frac{3}{4}$ "

Allen Head Bolt

Qty. 2



Part# 12

$\frac{3}{8}$ "

Nylon Nut

Qty. 2

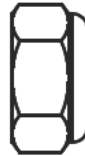
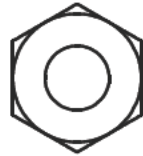

Part# 13

M10

Nylon Nut

Qty. 20

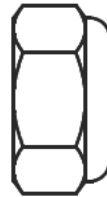
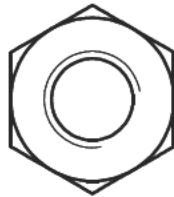

Part# 14

$\frac{1}{2}$ "

Nylon Nut

Qty. 4



Part# 15

$\frac{1}{2}$ " x 13mm

Nut

Qty. 2



Part# 16

M12

Nylon Nut

Qty. 4

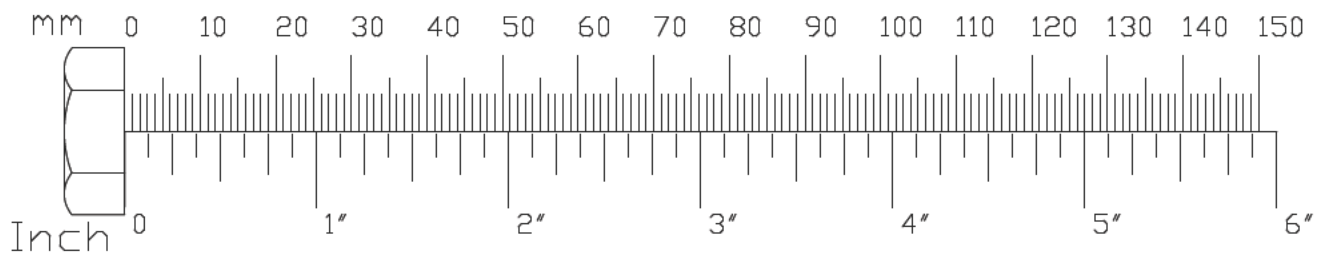

Hardware (To Scale)

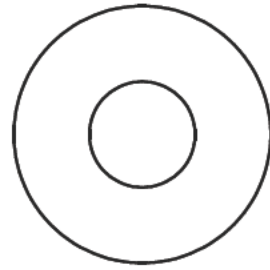

Part# 17

1/2" ID

Washer

Qty. 8

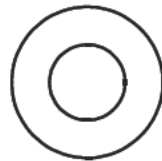

Part# 18

3/8" ID

Washer

Qty. 4

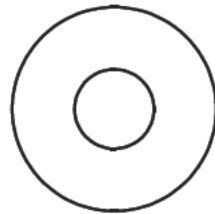

Part# 19

M10 ID

Washer

Qty. 28



Part# 22

3/8"

Spring Washer

Qty. 2

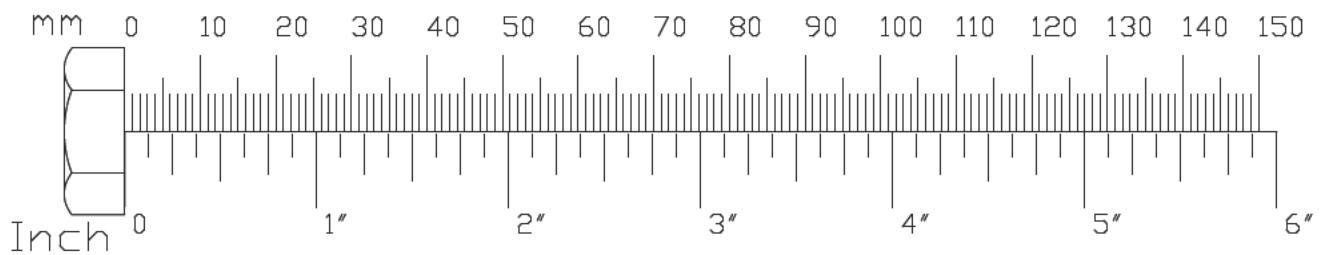

H a r d w a r e (T o S c a l e)



Part# 23

1/2"

Spring Washer

Qty. 2

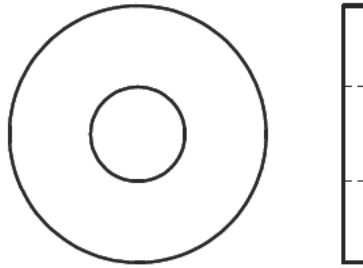

Part# 24

M12

Washer

Qty. 4

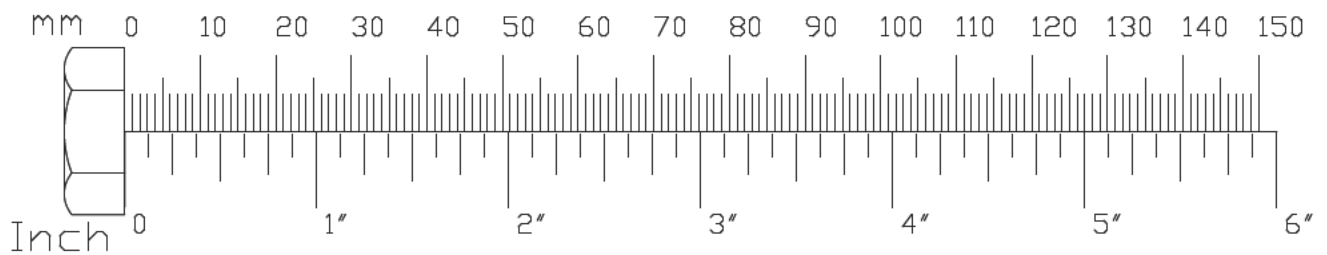

Exploded View Diagram

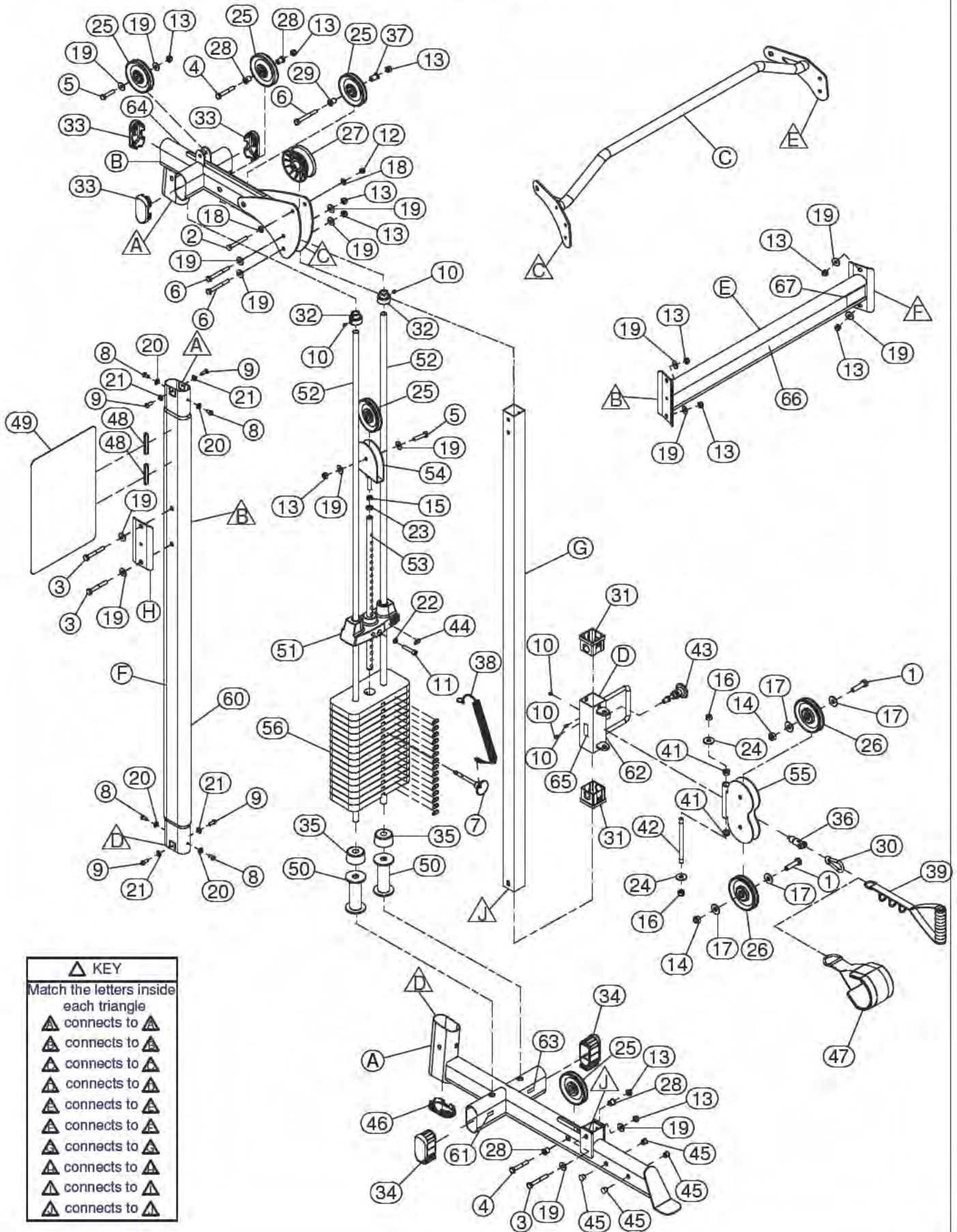

△ KEY	
△	connects to △
△	connects to △
△	connects to △
△	connects to △
△	connects to △
△	connects to △
△	connects to △
△	connects to △
△	connects to △
△	connects to △

Body-Solid[®]
Built for Life

1900 S. Des Plaines Ave.
Forest Park, IL 60130
1 (800) 556-3113
Hours: M-F 8:30 - 5:00

www.bodysolid.com