





# GENUINE TRAILER HITCH KIT

## INSTALLATION AND USER'S INSTRUCTIONS

Thank you for purchasing a Genuine Mazda Accessory.  
Before removal and installation, please thoroughly read these instructions.  
For your safety, please read the contents of this booklet to properly install and use the trailer hitch kit.  
Keep these instructions with your vehicle records for future reference.

### **WARNING**

- There are several  **WARNING** and  **CAUTION** sections in this booklet concerning safety when installing or removing the trailer hitch kit. Always read and follow the instructions in order to prevent injuries, accidents, and possible damage to the vehicle.
  -  **WARNING:** Indicates a situation in which serious injury or death could result if the warning is ignored.
  -  **CAUTION:** Indicates a situation in which bodily injury or damage to the vehicle could result if the caution is ignored.
- For areas indicating the tightening torque in this instruction manual, tighten to the specified torque by using a torque wrench. For areas in which the tightening torque is indicated inside parentheses ( ), the tightening torque is indicated as a reference value, however tightening using a torque wrench is not necessary
- Do not modify the trailer hitch kit .
- Do not install the trailer hitch kit in any way other than described in the following instructions.
- If in doubt, please contact your Mazda dealer to install the accessory in order to prevent errors in installation.
- If you have any questions about the use of the accessory, ask your Mazda dealer for proper advice before using it.
- Mazda and its suppliers are not responsible for injuries, accidents, and damage to persons and property that arise from the failure of the dealer or installer to follow these instructions.
- To ensure safety and reliability of the work, installation, removal and disposal work must be carried out by an Authorized Mazda Dealership.
- Be careful not to lose removed parts, and be sure that they are kept free of dirt, scratches, or damage.

<b>PART NAME:</b>	<b>TRAILER HITCH KIT</b>
<b>PART NUMBER:</b>	<b>VA40-V3-920</b>
<b>VEHICLE:</b>	<b>CX-50</b>

### NOTE

#### To the dealer

- Please turn over these instructions to the customer after installation.

#### To the customer

- Keep these instructions after installation. The instructions may be necessary for installing other optional parts or removal of this accessory.
- Should the vehicle or this accessory be resold, Always transfer these instructions to the next owner.



GENUINE ACCESSORIES

### Installation Instructions

**Part Number:**  
VA40-V3-920

**Trailer Hitch Kit**

**Applicable Models:**  
2022 > CX-50





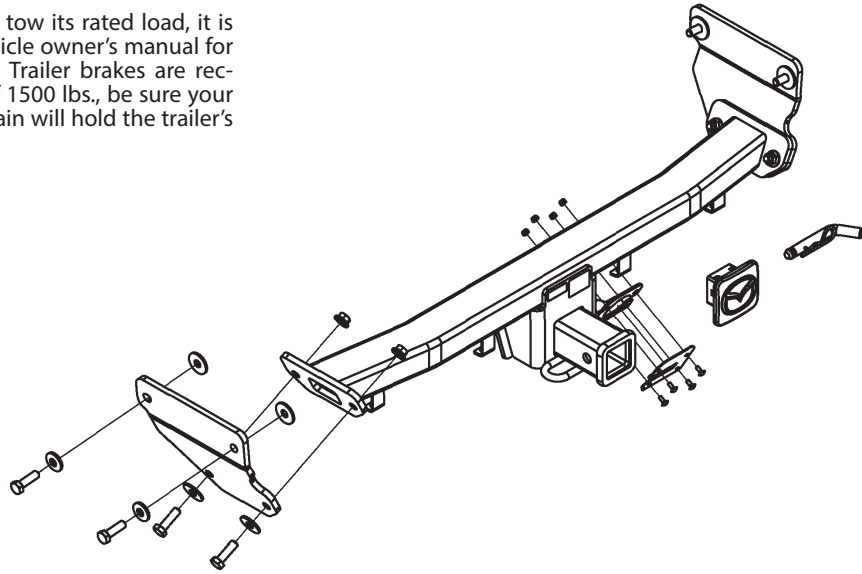

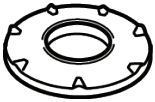

**WARNING:**

Although this hitch is designed to safely tow its rated load, it is recommended that you consult your vehicle owner's manual for further recommendations or limitations. Trailer brakes are recommended for towing loads in excess of 1500 lbs., be sure your trailer has safety chains and that each chain will hold the trailer's maximum gross weight.

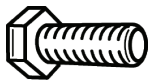
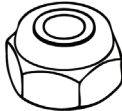

#### Hardware Kit Contents

#### Tools Required

<b>A</b> 4X  Conical washer	<b>B</b> 8X  Flat washer	<b>C</b> 4X  #10-24 bolt
<b>D</b> 8X  M12-1.25 bolt	<b>E</b> 4X  #10-24 nut	<b>F</b> 4X  M12-1.25 nut
<b>G</b>  Hitch plug	<b>H</b>  Pin and Clip	<b>I</b>  Electrical plate
<b>J</b>  Installation instructions	<b>K</b>  User guide	

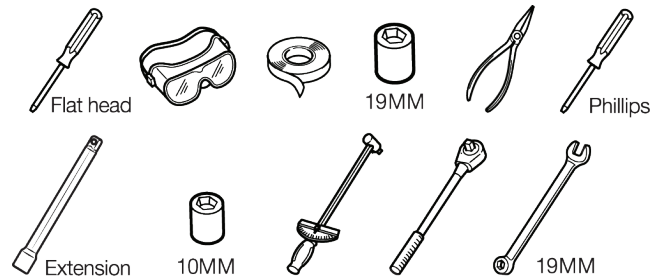

#### Notes

- A)** Read installation instructions before proceeding.
- B)** Do not damage paint or kit components.
- C)** Do not over tighten bolts. Tighten to specified torque.
- D)** Thoroughly clean installation areas.
- E)** Two persons are needed for some steps to be completed.

## 01 Remove Bumper Support

### Tools Needed:

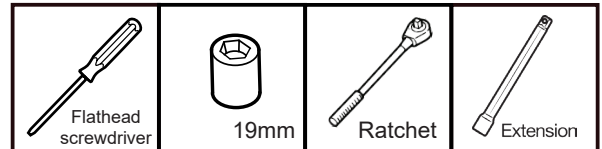

- Remove four plastic fasteners on bumper support.
- Remove two screws on bumper support.
- Remove and discard bumper support and screws.
- Set plastic fasteners aside for reinstallation.

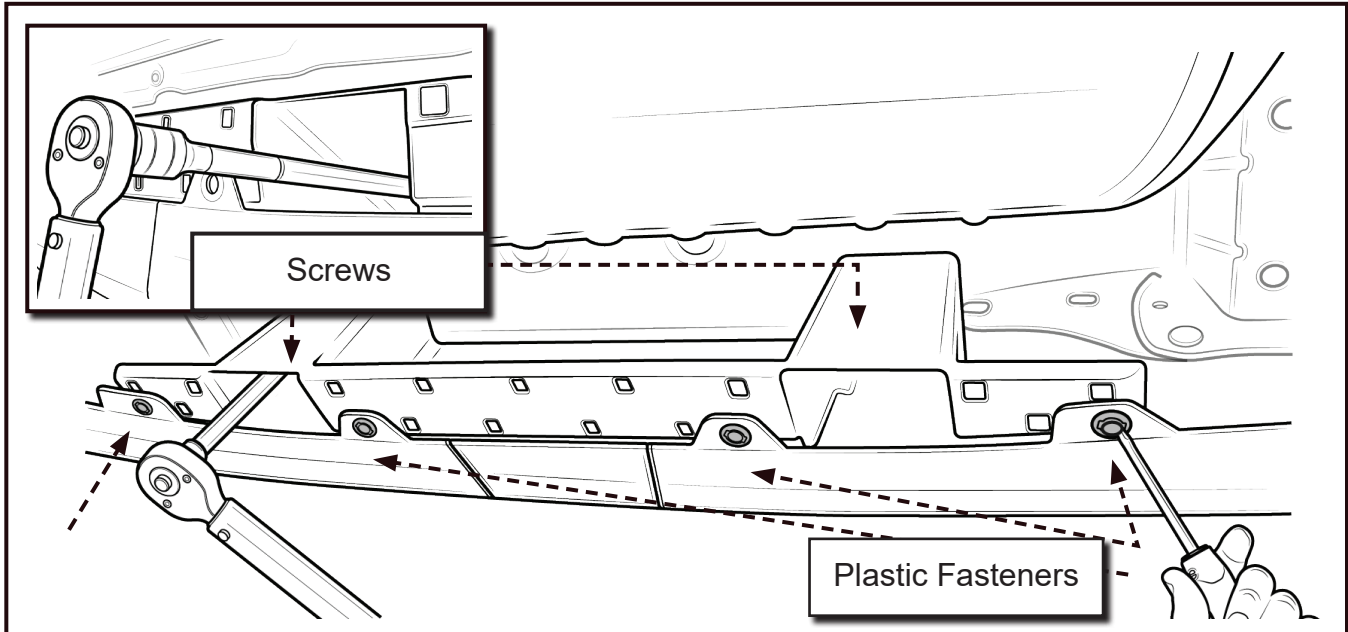

## 02 Remove Bumper Cover

### Tools Needed:

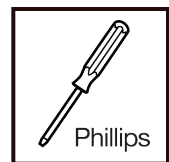

- Remove two screws on bumper cover.
- Remove and discard bumper cover.

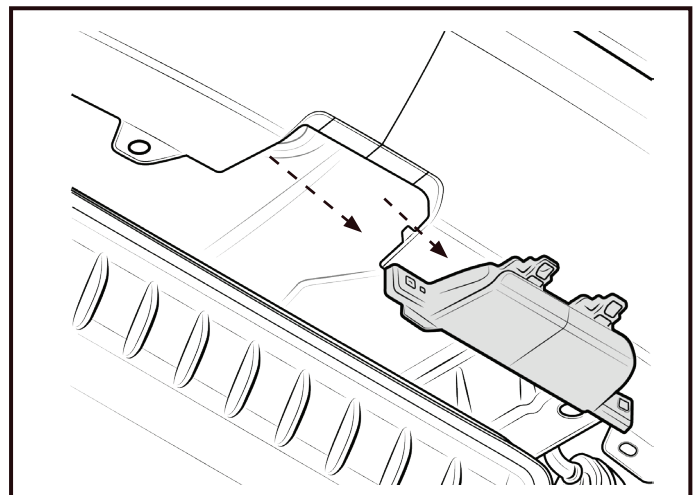
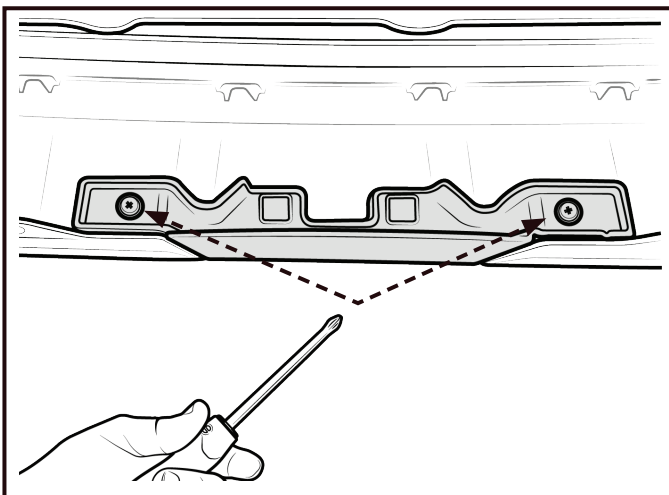

### 03 Driver and Passenger Side Frame Rail

Tools Needed:

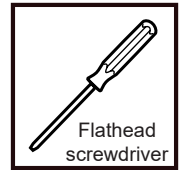

- Puncture and remove protective tape on outside of the driver and passenger side rail.

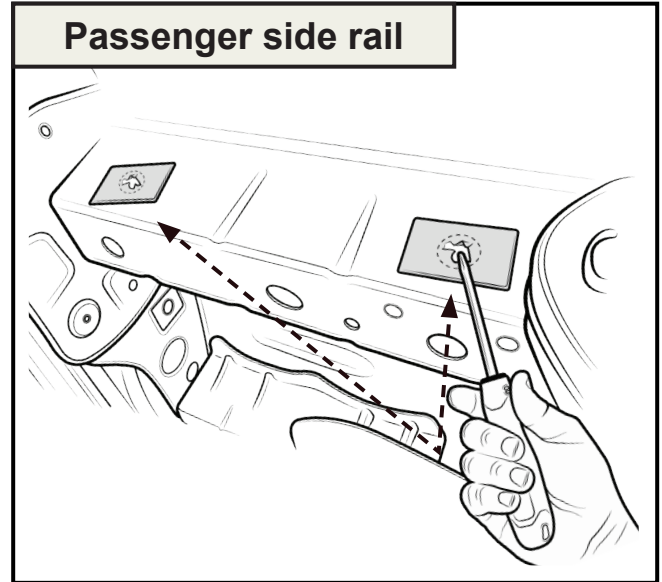
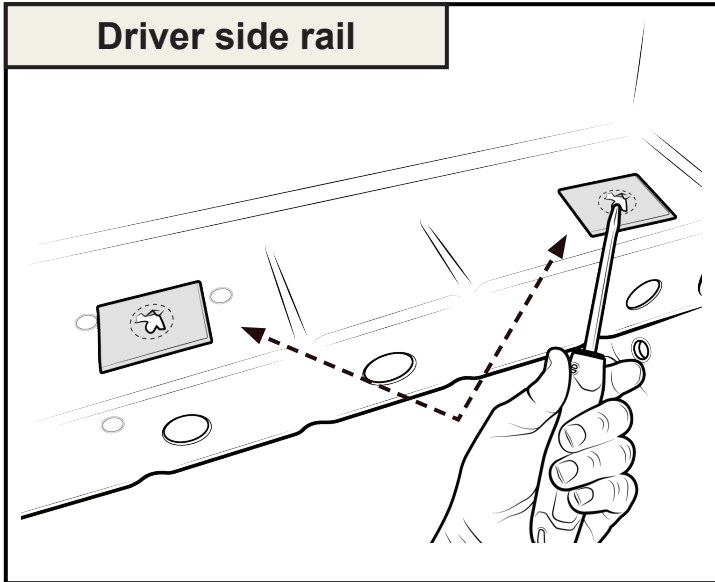

### 04 Driver Side Frame Rail

Tools Needed:

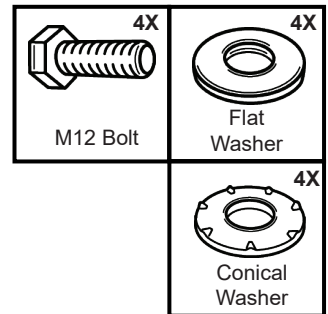

- A) Tape M12 flat washers to the inside of the side plates as shown in figure A.
  - B) Note the hardware configuration of the side plates in figure B.
- **Note: Be sure teeth on conical washers are facing away from the bolt head.**

Trim excess mastic before installing side plates (if it will cause an interference with install.)

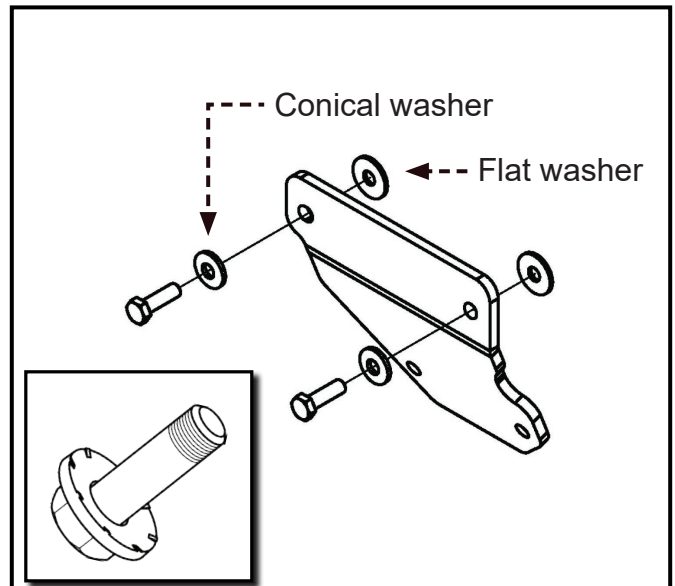
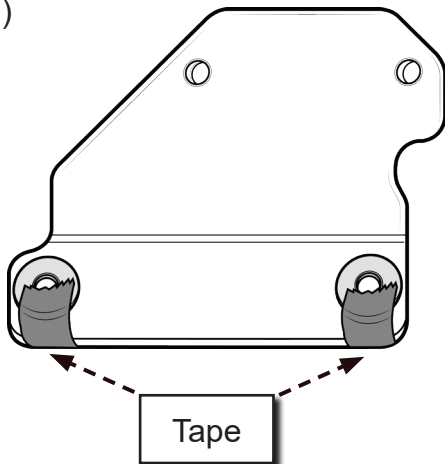

## Loosely Bolt Drive Side Plate

- Position side plate onto driver side rail and use the M12 bolts, conical washers, and flat washers to assemble.
- **Note: Be sure side plates are positioned so they angle towards the center of the vehicle.**

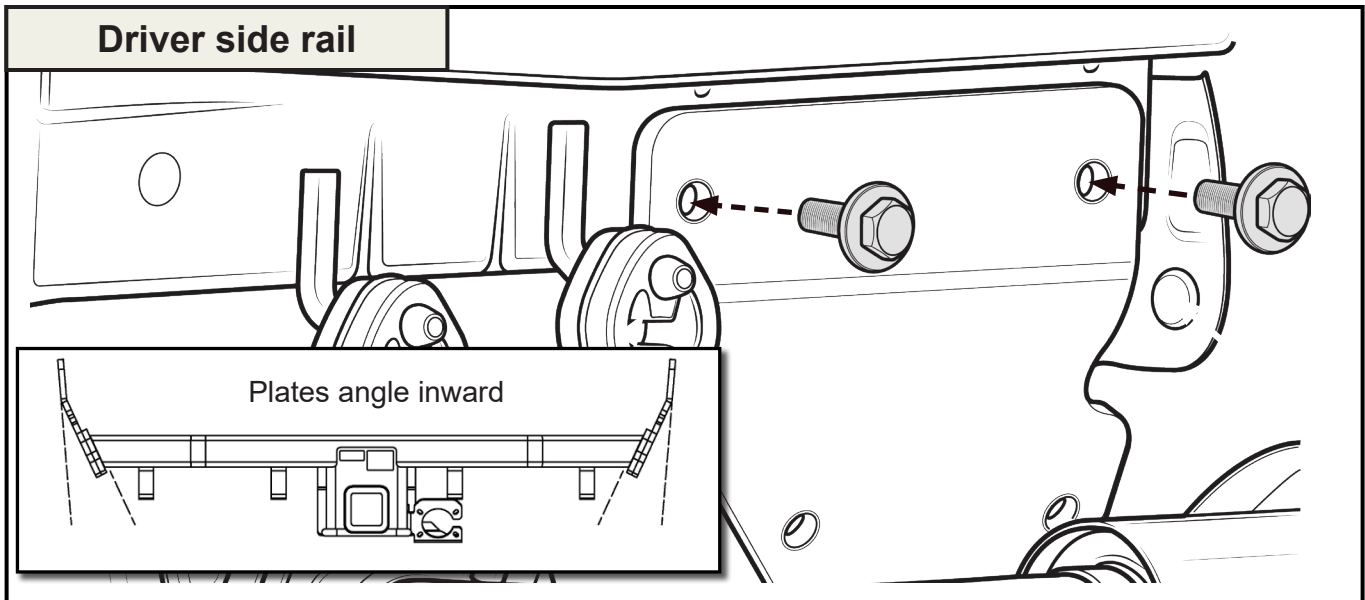

## Loosely Bolt Passenger Side Plate

- Position the passenger side plate in the same configuration as stated above.
- **Note: Be sure side plates are positioned so they angle towards the center of the vehicle.**

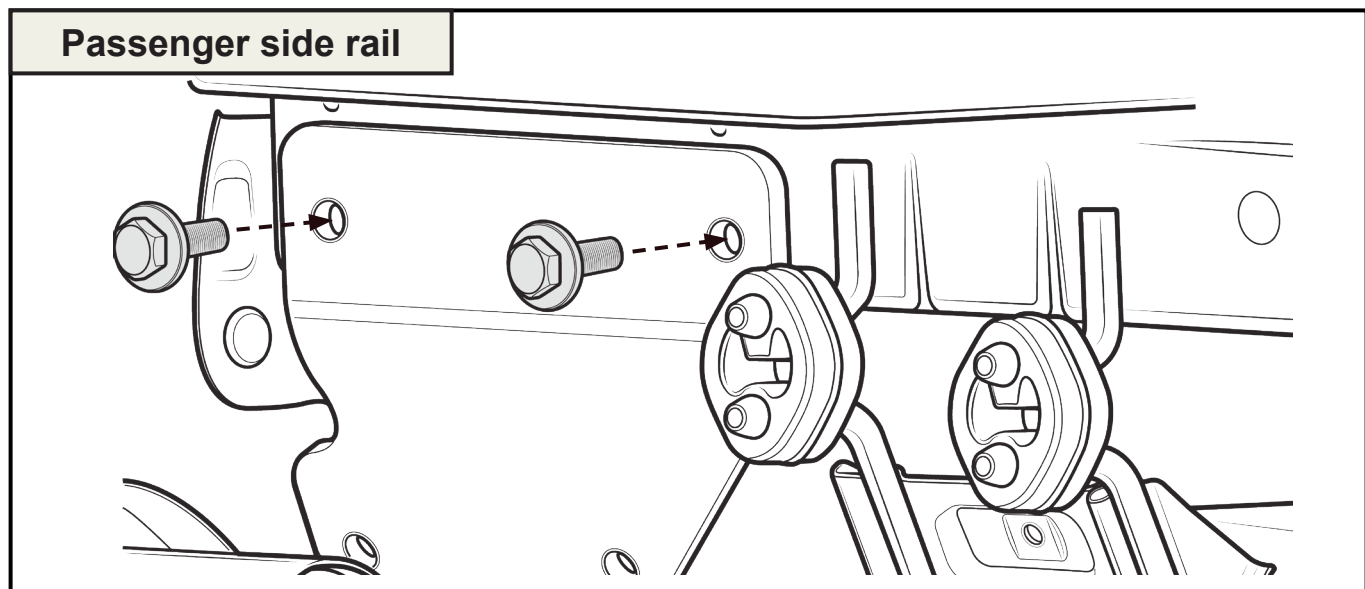

## 05 Main Hitch Assembly (Two People Required)



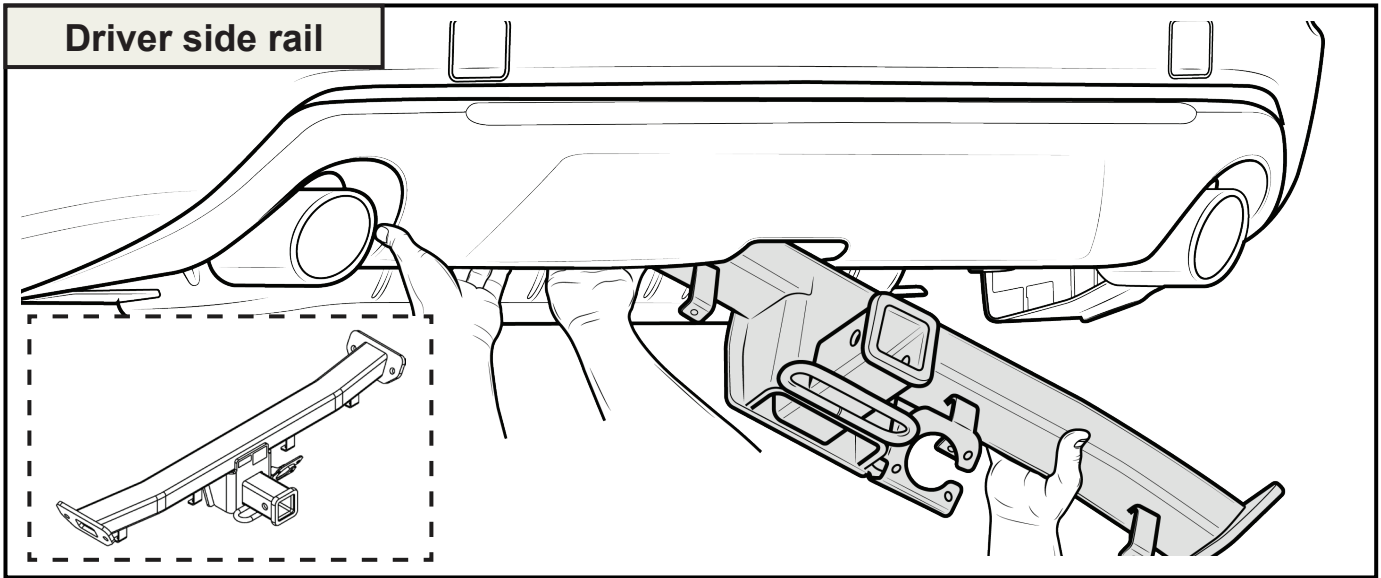



- Person 1: Gently pull rear bumper fascia and metal fascia attachment brackets rearward to allow for main hitch insertion.
- Person 2: Insert main hitch into position.



## 06 Loosely Attach Side Plates to Main Hitch

- Fasten side plates to main hitch using M12 bolts, flat washers, and M12 nuts (see figure A).
- **Note: Be sure serrations in nut are against main hitch plate.**

### Tools Needed:

 19mm 4X	 Ratchet 4X	 19mm 4X
 M12 Bolt	 Flat washer	 M12 Nut

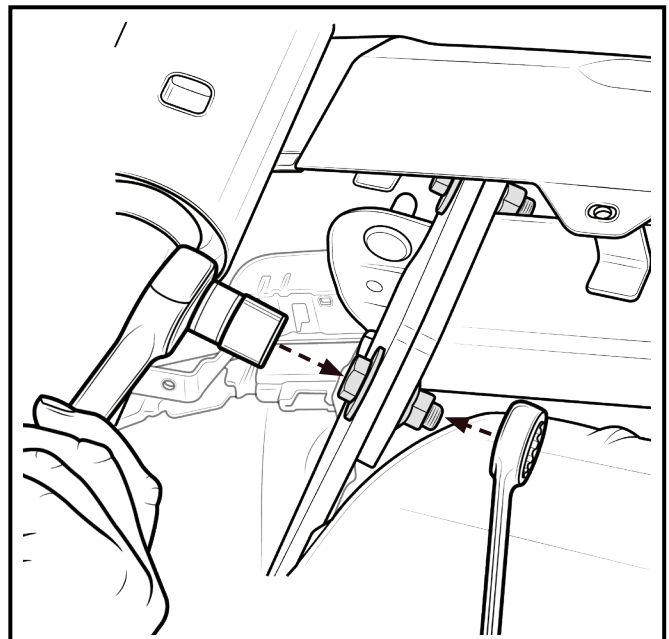
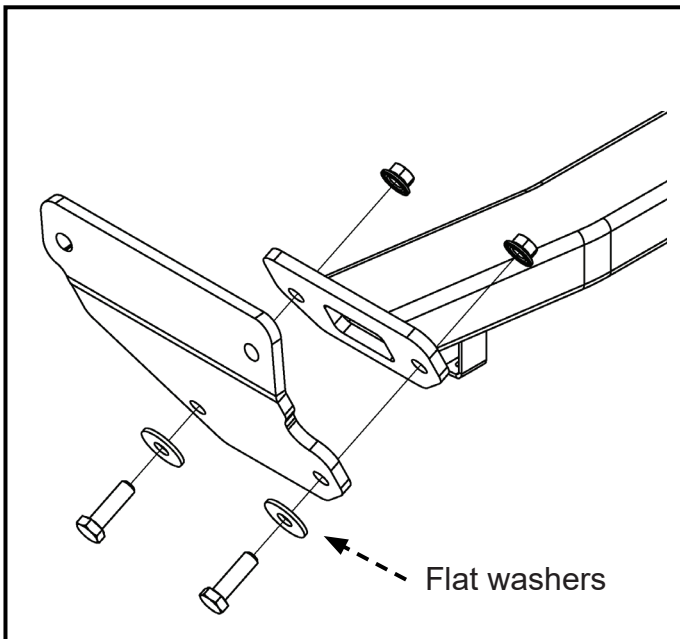

## 07 Torque Hardware

### Tools Needed:

- Fully tighten side plates and bolts attaching side plates to main hitch and frame rail as shown.

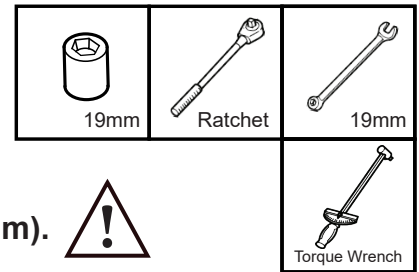

**!** Torque all 8 bolts to 86.2 ft. lbs (116.9 Nm). **!**

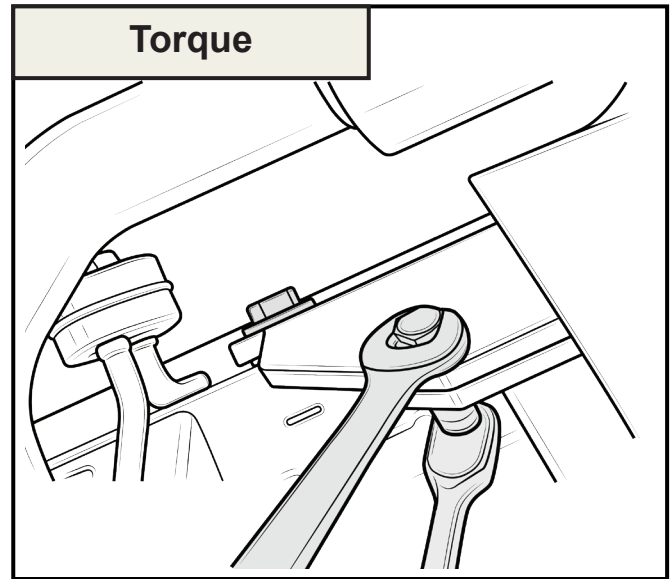
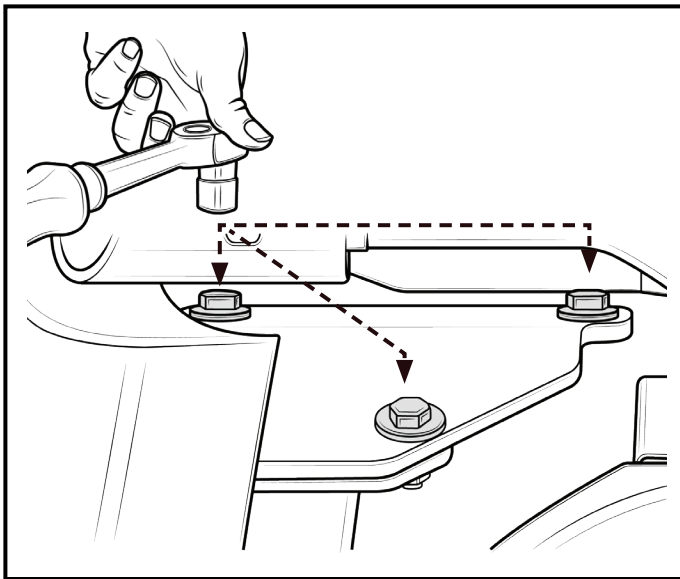

## 08 Reinstall Plastic Fasteners

- Align four hitch bumper support tab holes with fascia holes.
- Insert four plastic fastener(s) into bumper support tab and fascia holes.

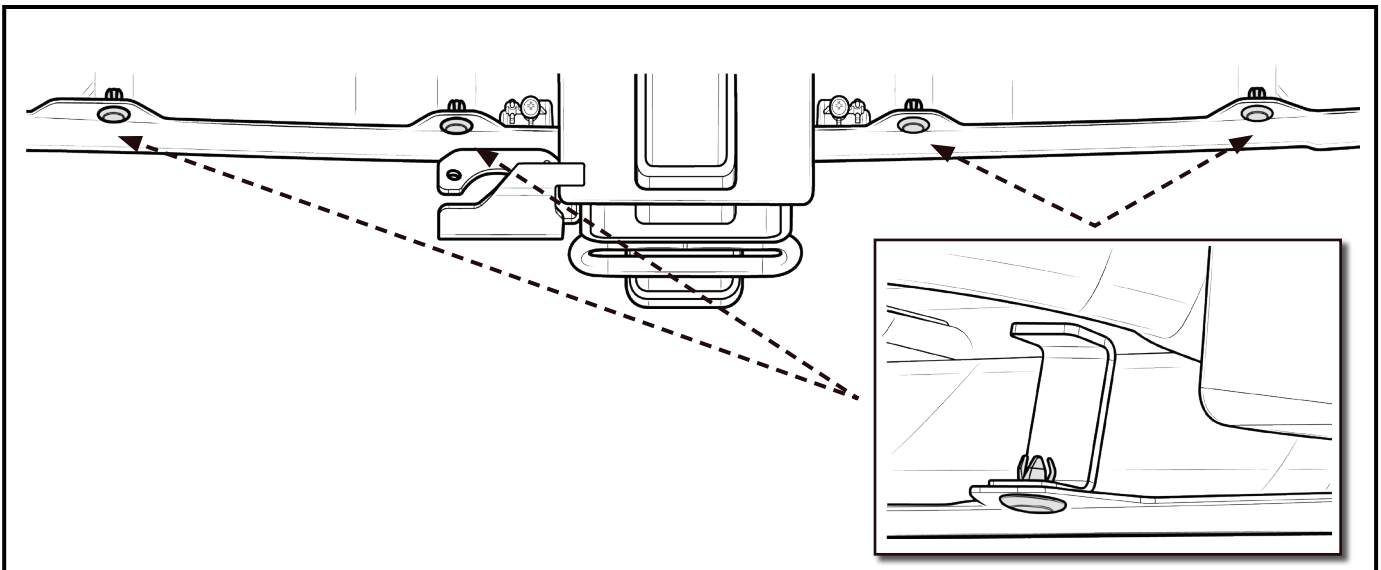

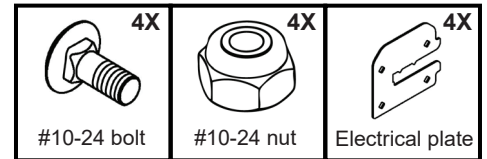
**09****Attach 4-Pin Harness to Hitch (Non-Turbo Models Only)****Tools Needed:**

- Attach the harness with the four passenger side holes on back of main hitch. (See electrical instructions)
- Slide 4-pin connector into electrical plate.
- Bolt electrical plate to hitch bracket as shown below.

**Torque all four nuts to 19.5 ft. lbs (2.2 Nm).**

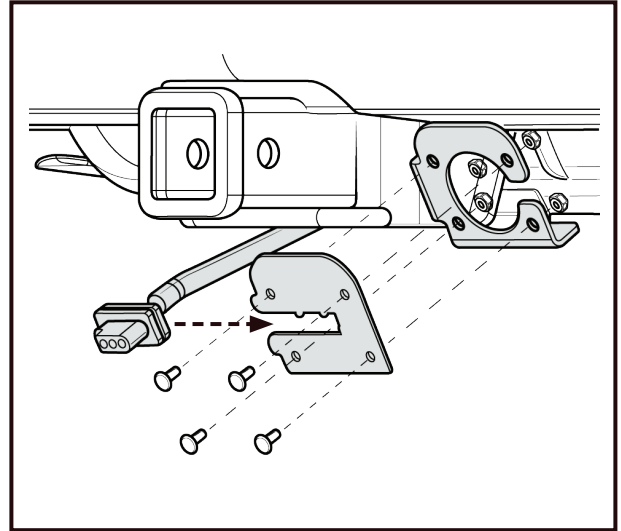
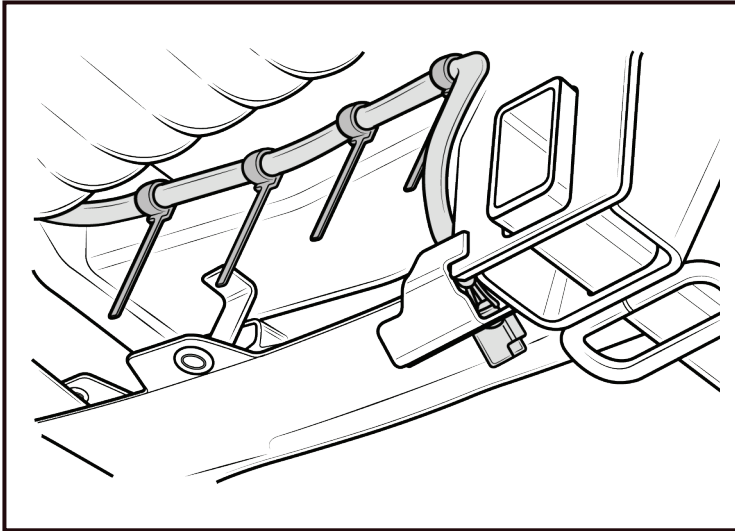
**10****Attach 7-Pin Harness to Hitch (Turbo Models Only)**

- Attach the harness to the hitch using the four holes in the main hitch on passenger side. (See electrical instructions)
- Bolt 7-pin harness to hitch bracket. (See electrical instructions)

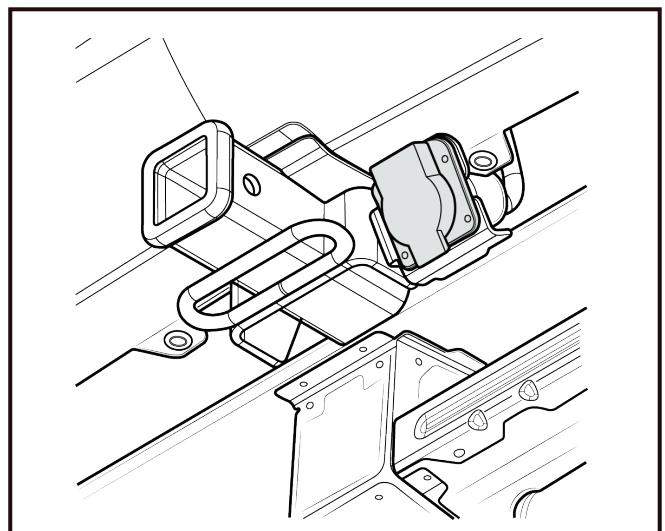
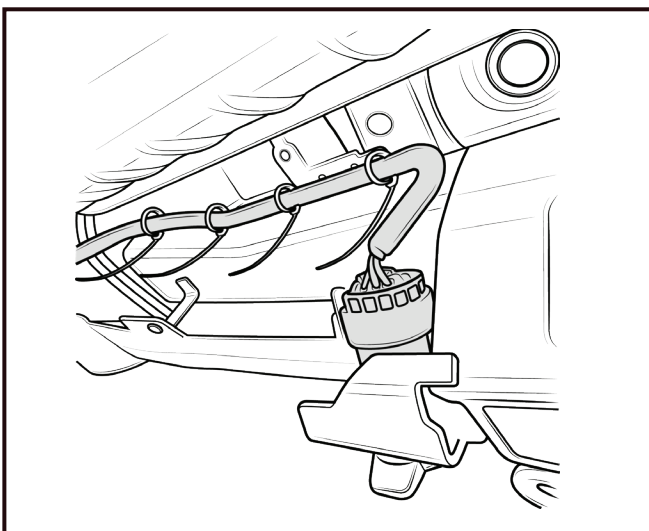



## Finishing Steps

- Clean vehicle surface and debris.
- Reinstall trim clips under rear bumper fascia.
- Check torque on all bolts.
- Place user guide and hitch plug into the glove box.

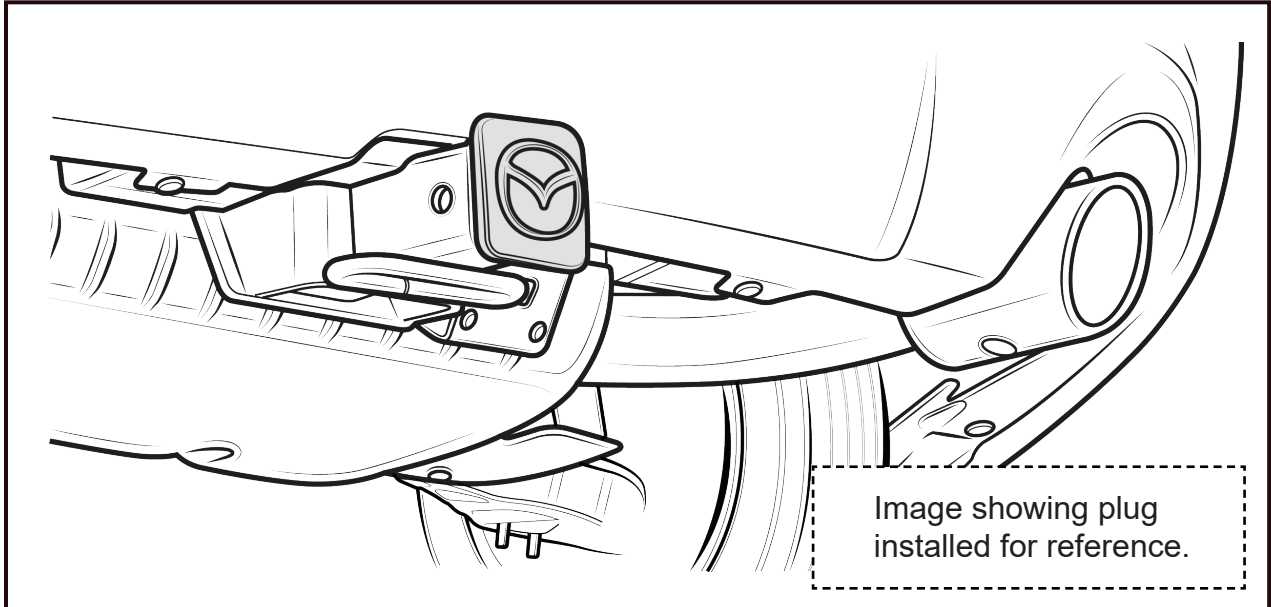
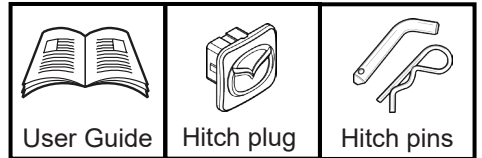

**INSPECTION: TRAILER HITCH KIT**

VA40-V3-920

Inspection intended with trailer hitch installed.

Inspect the installed / reinstalled parts for the following items:

Inspection Part	Inspection Items (O)			
	Clearance and fit	Scratches and dirt	Installation, tightening and engagement	Operation check
Bumper fascia fastened to hitch in four locations	--	--	O	-
Receiver hitch torqued down	O	O	*1 O	O
User guide and hitch plug	--	--	*2 O	--

O: Applicable



**\*1: Eight bolts to 86.2 ft. lbs. (116.9 N.m.)**



\*2: In vehicle glove box

Date: \_\_\_\_\_

Vehicle: \_\_\_\_\_

VIN: \_\_\_\_\_

Approved

Checked

Person in charge