

## INSTALLATION INSTRUCTIONS

**PART NUMBER:**

0000-8T-D36

Scuff Plate

**APPLICABLE MODELS:**

2016 ≥ MAZDA MX-5

**PACKAGE CONTENTS:**



FRONT SCUFF PLATE (Qty 2)

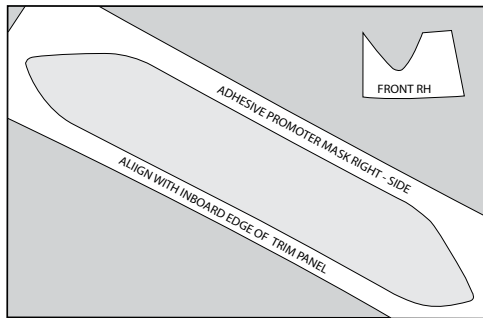

TEMPLATE (Qty 2)



ADHESION PROMOTER (Qty 2)



ALCOHOL WIPE (Qty 2)

**TOOLS REQUIRED:**



LINT FREE CLOTH

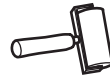

RUBBER ROLLER



MASKING TAPE

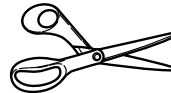

SCISSORS



**CAUTION:** Failure to install this part correctly could result in damage to the vehicle and/or injury to the customer. Make sure to follow the instructions properly to ensure a good installation. Read the entire installation instructions before proceeding.

**1. Prepare Vehicle**

- A. Vehicle and scuff plate should be at 13 degrees Celcius - 32 degrees Celcius (55 degrees Farenheight - 90 degrees Farenheight) for best results.
- B. Clean all dirt or other contaminants from surface.

- C. Using alcohol and cloth thoroughly clean surface to be adhered to.
- D. Allow sill area to completely air dry.

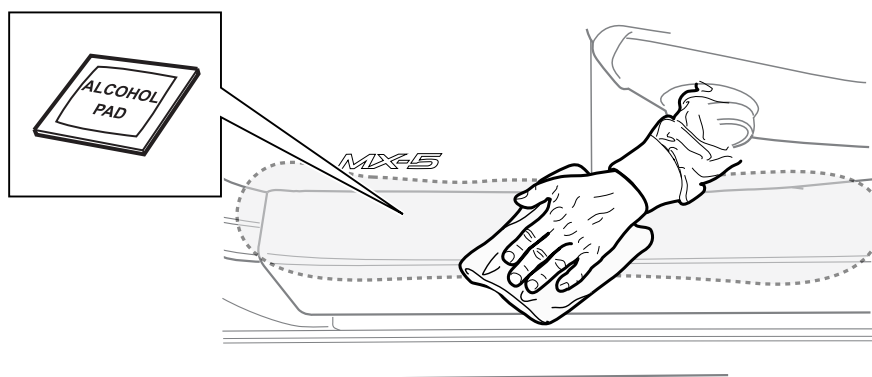

Figure 1

2. Cut Templates:

- A. Use scissors to cut out templates (Figure 2).

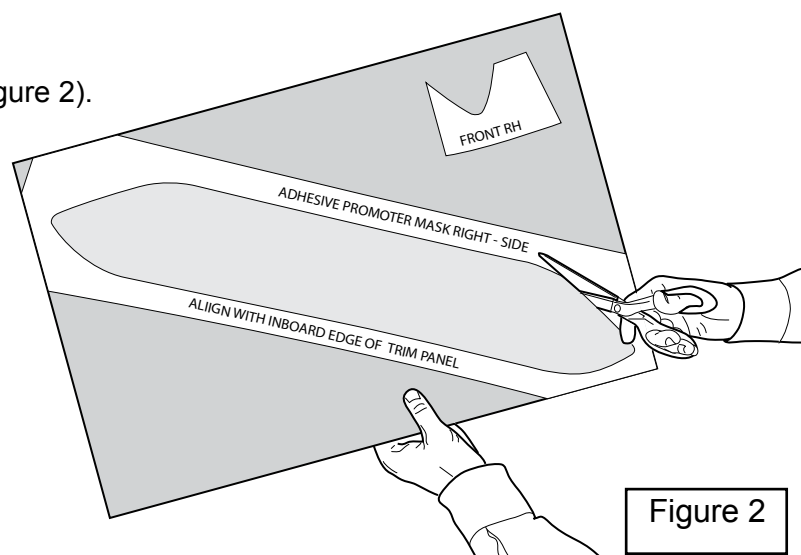

Figure 2

3. Adhesion Promoter Masking Template:

- A. Visually align the Masking Template with the front edge and the lower edge of the inner door sill trim panel.
- B. Tape into place.

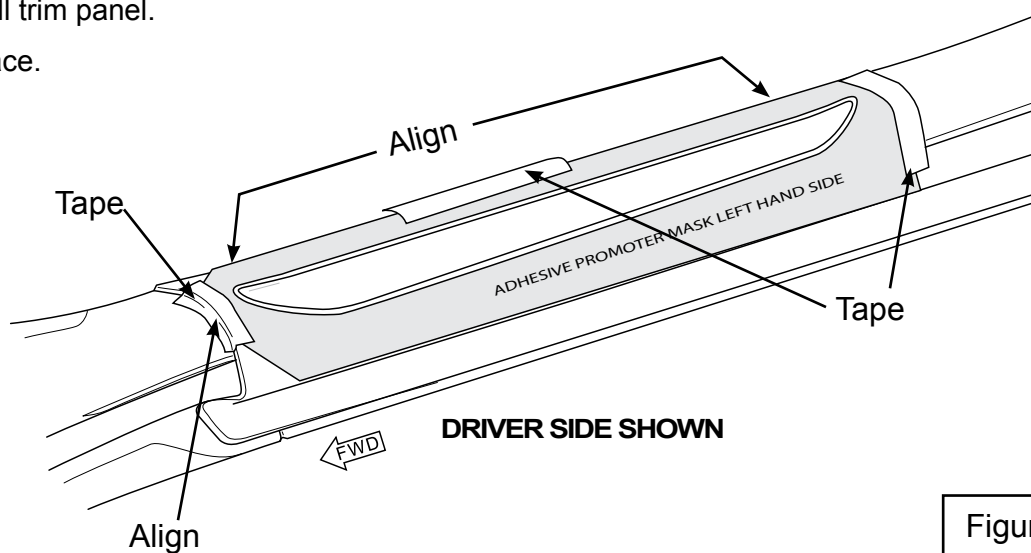

Figure 3

11/19/15

4. Apply Adhesion Promoter.

- A. Apply Adhesion Promoter to the cut-out area of Masking Template only. Wipe from the edge of the Masking Template towards the center of the cut-out area.
- B. Remove Masking Template.
- C. Allow to dry for 2 -3 minutes.

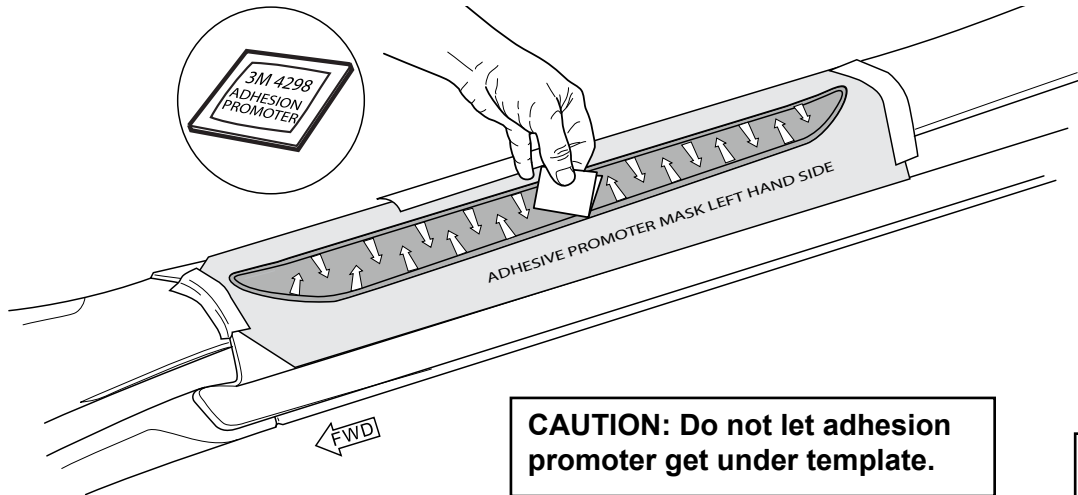

Figure 4

5. Visually align the Template with the front edge of the inner door sill trim panel:

- A. Tape into place.

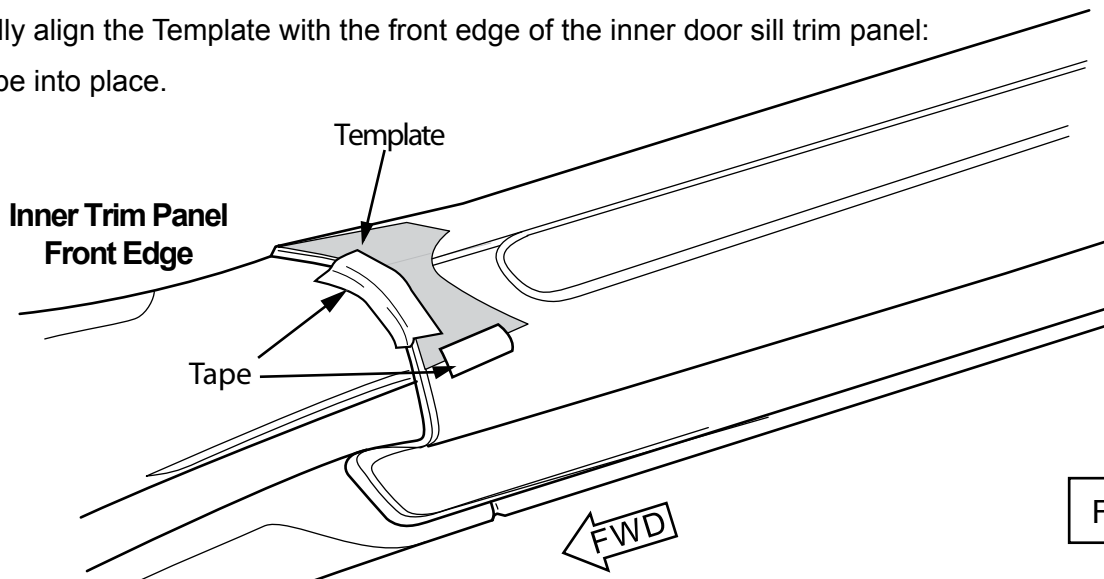

Figure 5

6. Scuff Plate Preparation:

- A. Locate Scuff Plate marked as LH and remove the backing from the tape and discard. (Figure 6)

Adhesive Backing

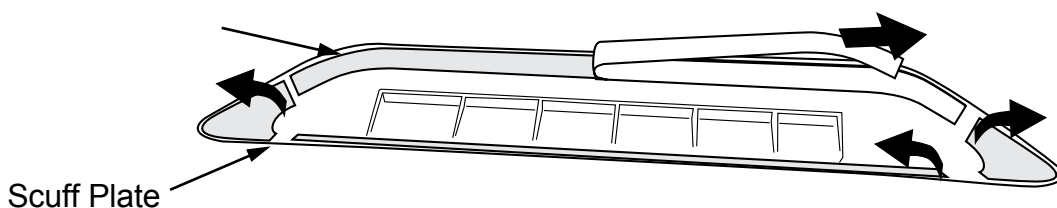

Figure 6

7. Place Scuff Plate:

- A. Carefully align Scuff Plate with the Template and press down flat into position. (Figure 7)
- B. Remove the Template.

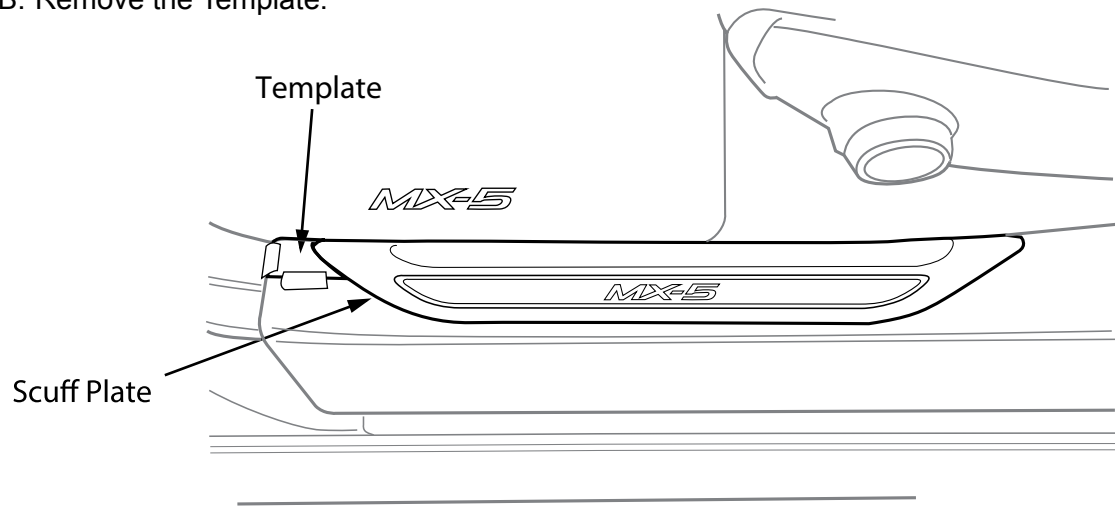

Figure 7

8. Apply pressure to the placed Scuff Plate:

- A. Use a Rubber Roller, from center out, press down the perimeter of part to ensure proper wet-out of adhesive. (Figure 8) (Use caution to ensure roller does not scratch vehicle.)
- B. Pull the Green Tab to remove the clear protective film over the logo.
- C. Wipe Clean the Scuff Plate and Sill Area of all marks and other debris.

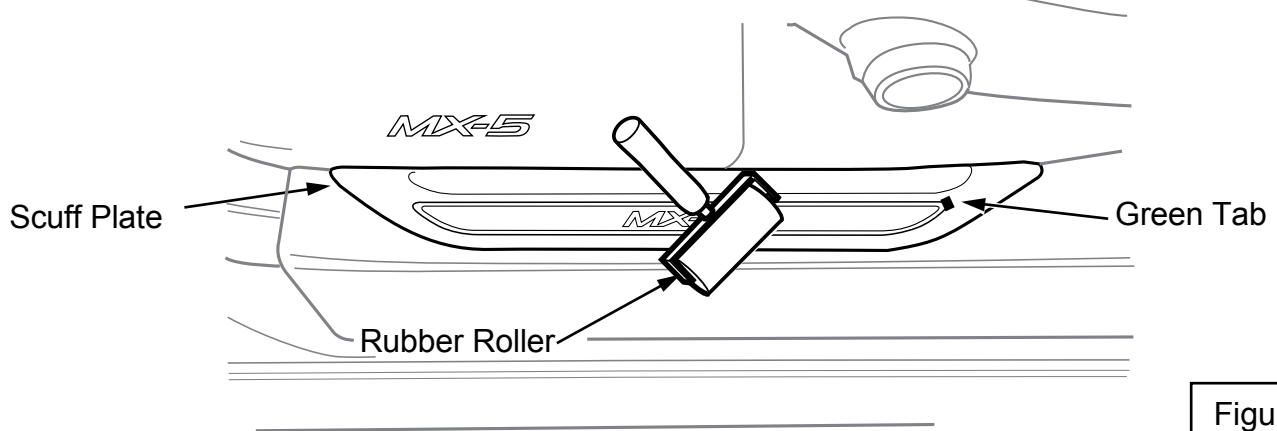

Figure 8

9. Inspect for proper adhesion and placement:

- A. Verify the part is not loose at any corner, and that the part is located parallel to the sill panel down turn.

10. Installation of Passenger Side Scuff Plate:

- A. Repeat Previous steps for Passenger side.

# Installation Inspection Sheet.

[To be used by installation workshop]

Mazda MX-5	Scuff Plates
	2016 ≥, All models

Inspection Items after installation

Inspect the installed parts per the items listed below

Section to be Inspected	Inspection Item (circle)		
	Gap & Fit	Scratches/stains	Tape residue/fingerprints
Front Scuff Plate	○	○	○

Date		(year/month/day)			
VIN No.					
Approved		Checked		Prepared	

\*Retention period of this sheet: 12 months