

GENUINE MUD FLAP (REAR)

INSTALLATION INSTRUCTIONS

Thank you for purchasing a Genuine Mazda Accessory.

Before removal and installation, Please thoroughly read these instructions.

For your safety, please read the contents of this booklet to properly install and use the mud flap (rear).

Keep these instructions with your vehicle records for future reference.



- There are several **⚠ WARNING** and **⚠ CAUTION** sections in this booklet concerning safety when installing or removing the mud flap (rear). Always read and follow the instructions in order to prevent injuries, accidents, and possible damage to the vehicle.

⚠ WARNING: Indicates a situation in which serious injury or death could result if the warning is ignored.

⚠ CAUTION: Indicates a situation in which bodily injury or damage to the vehicle could result if the caution is ignored.

- For areas indicating the tightening torque in this instruction manual, tighten to the specified torque by using a torque wrench. For areas in which the tightening torque is indicated inside parentheses (), the tightening torque is indicated as a reference value, however tightening using a torque wrench is not necessary
- Do not modify the mud flap (rear).
- Do not install the mud flap (rear) in any way other than described in the following instructions.
- If in doubt, please contact your Mazda dealer to install the accessory in order to prevent errors in installation.
- If you have any questions about the use of the accessory, ask your Mazda dealer for proper advice before using it.
- Mazda and its suppliers are not responsible for injuries, accidents, and damage to persons and property that arise from the failure of the dealer or installer to follow these instructions.
- To ensure safety and reliability of the work, installation, removal and disposal work must be carried out by an Authorized Mazda Dealership.
- Be careful not to lose removed parts, and be sure that they are kept free of dirt, scratches, or damage.

PART NAME: MUD FLAP (REAR)

PART NUMBER: NA1J V3 460

NA1P V3 460

NA6R V3 460

VEHICLE: MAZDA MX-5

NOTE

To the dealer

- Please turn over these instructions to the customer after installation.

To the customer

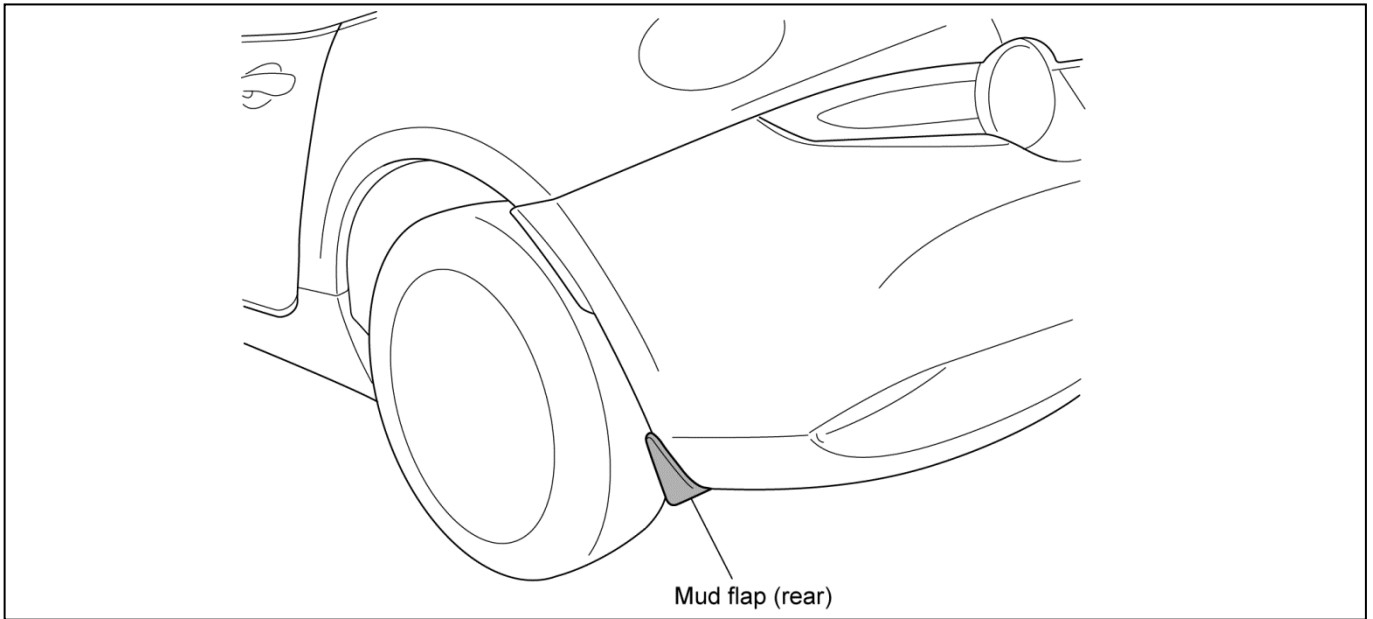

- Keep these instructions after installation. The instructions may be necessary for installing other optional parts or removal of this accessory.
- Should the vehicle or this accessory be resold, Always transfer these instructions to the next owner.

1. INSTALLATION VIEW

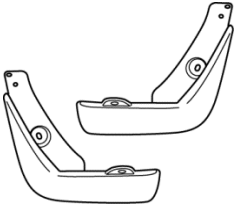

2. PARTS

- Before installation, verify that the kit includes all the following parts and that they are free of dirt, scratches, or damage.

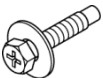
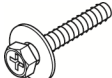
Part	Part name	Qty	Part	Part name	Qty
	Mud flap (rear) (RH/LH)	Each 1		Clip nut	4
	Bolt	4		Tapping screw	2

3. BEFORE INSTALLATION

■ REQUIRED TOOLS

☆Nippers

☆Phillips screwdriver (stubby type)

☆Fastener remover

⚠ WARNING

Park the vehicle on a flat, level surface, set the selector lever to P (AT vehicles) or the shift lever to 1st or R (MT vehicles), apply the parking brake and block the wheels so that the vehicle does not move during installation.

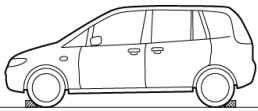

⚠ CAUTION

Be sure to cover the vehicle body with protectors or mats to prevent stains, scratches and damage when removing/installing the vehicle parts

Using improper tools may cause damage and or broken parts. Use the correct tool for the installation.

Wrap protective tape around screwdrivers and fastener remover tools to prevent scratching the vehicle.

Put the removed parts and the parts in the kit on the protective sheet to prevent scratches.

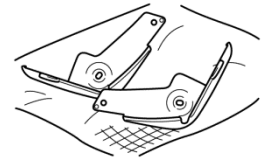
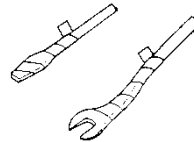
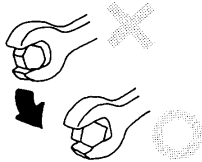
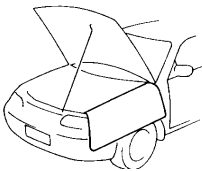

Advice

Refer to the Workshop Manual for removal and installation of vehicle parts. Not following the procedures for removal/installation in the Workshop Manual could result in an accident or vehicle malfunction.



4. MUD FLAP (REAR) INSTALLATION

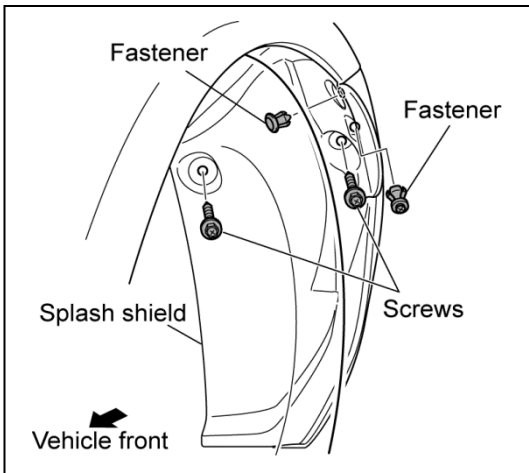

1. Remove the splash shield fasteners (2 places) and the screws (2 places).

- The removed fasteners and screws will be reused.

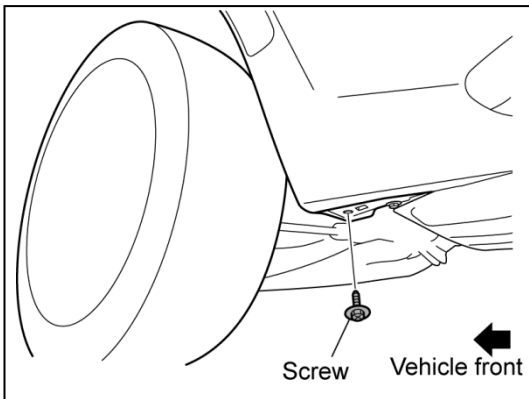

2. Remove the screw at the bottom of the splash shield (1 place), and then remove the splash shield.

- The removed screw will not be reused.
- The splash shield is held onto the bumper with the three clips. Push toward the inside of the vehicle to remove.

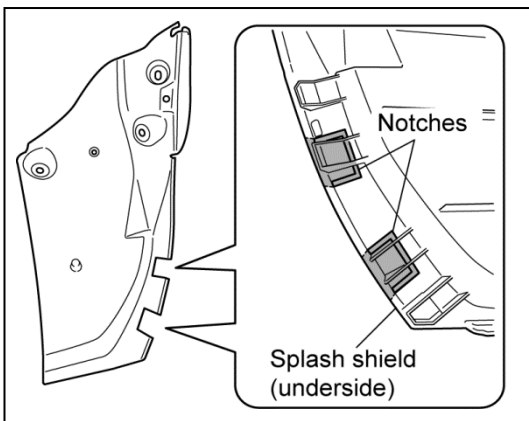
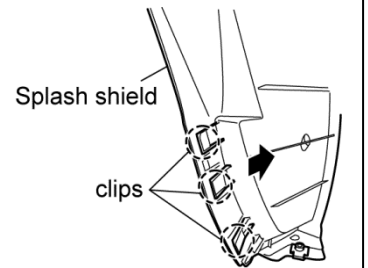

3. Use a nipper or similar to cut the splash shield along the notches on the underside of the splash shield. (2 places)

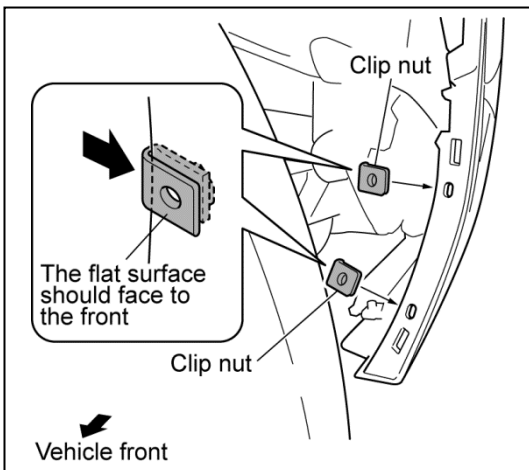

4. Install the clip nuts to the rear bumper (2 places).

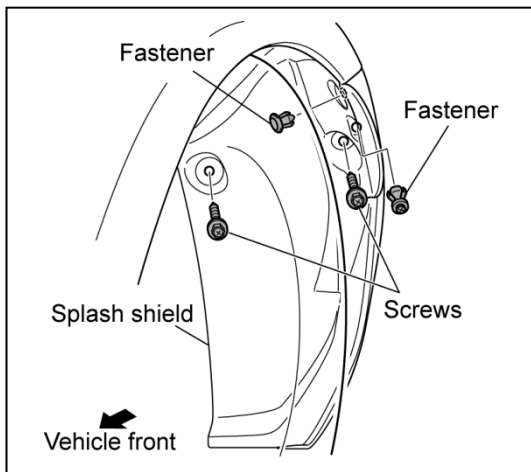

5. Install the splash shield with the fasteners (2 places) and the screws (2 places).

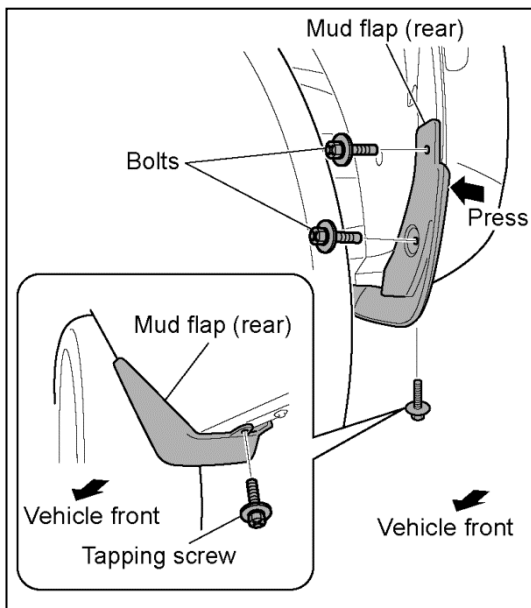

6. While pressing the mud flap (rear) against the vehicle so that there are no gaps, install it by using the bolts (2 places) and the tapping screw (1 place).

Bolt tightening torque: (1.5-2.0 N·m)

Tapping screw tightening torque: (0.6-0.9 N·m)

- If there are any gaps, loosen the bolts and the tapping screw, and then re-tighten them while pressing the mud flap (rear) against the vehicle.

7. Install on the opposite side in the same way.