





# GENUINE SPLASH GUARD (FRONT)

## INSTALLATION AND USER'S INSTRUCTIONS

Thank you for purchasing a genuine Mazda accessory.  
Before removal and installation, be sure to thoroughly read these instructions.  
Please read the contents of this booklet in order to properly install and use the splash guard.  
Your safety depends on it.  
Keep these instructions with your vehicle records for future reference.

### **WARNING**

- There are several  **WARNING** and  **CAUTION** sections in this booklet concerning safety when installing or removing the splash guard. Always read and follow them in order to prevent injuries, accidents, and possible damage to the vehicle.
-  **WARNING:** Indicates a situation in which serious injury or death could result if the warning is ignored.
-  **CAUTION:** Indicates a situation in which bodily injury or damage to the vehicle could result if the caution is ignored.
- For areas indicating the tightening torque in this instruction manual, tighten to the specified torque using a torque wrench. For areas in which the tightening torque is indicated inside parentheses (), the tightening torque is indicated as a reference value, however tightening using a torque wrench is not necessary.
- Do not modify the splash guard (front).
- Do not install the splash guard (front) in any way other than described in the following instructions.
- If in the any doubt, please ask your Mazda dealer to install the accessory in order to prevent errors in installation.
- If you have any questions about the use of the accessory, ask your Mazda dealer for proper advice before using it.
- Mazda and its suppliers are not responsible for injuries, accidents, and damage to person and property that arise from the failure of the dealer or installer to follow these instructions.
- To ensure safety and reliability of the work, installation, removal, and disposal work must be carried out by an Authorized Mazda Dealership.
- Be careful not to lose removed parts, and be sure that they are kept free from scratches, grease or other dirt.

**PART NAME:** Splash Guard Front (LH/RH)  
**VEHICLE:** CX-9  
**PART NUMBER:** 0000-8H-N28      0000-89-N28

#### NOTE

##### To the dealer

- Please turn over these instructions to the customer after installation.

##### To the customer

- Keep these instructions after installation. The instructions may be necessary for installing other optional parts or removal of this accessory.
- Should the vehicle or this accessory be resold, always leave these instructions with it for the next owner.



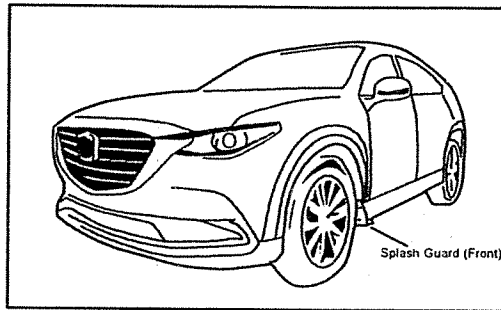





## 1. INSTALLATION VIEW



## 2. PARTS

### NOTE

- Before installation, verify that the kit includes all the following parts and that they are free of dirt, scratches, or damage.

A	(LH)	 x1	Splash Guard Front (LH)
B	(RH)	 x1	Splash Guard Front (RH)
C		 x4	U-nut Clip x 4
D		 x4	M5 Bolt x 4
E		 x2	Pull Rivet x 2
F			Deflector Plate (LH)
G			Deflector Plate (RH)
H			Adhesive Promoter Packet
I			Alcohol Wipe

### 3. BEFORE INSTALLATION

#### ■ REQUIRED TOOLS

- Screwdriver (Phillips)
- Torque wrench
- Socket wrench
- Soft clean cloth
- Protective sheets
- Nipper
- Isopropyl alcohol (IPA)
- Masking tape



#### WARNING

- Park the vehicle on a flat, level surface, set the selector level to P (AT vehicles), apply the parking brake and block the wheels so that the vehicle does not move during installation.



#### CAUTION

Use the most appropriate (size, use) tool for each task and perform the may be damaged.

Place the removed parts and kit accessories on a protective sheet to prevent scratches.

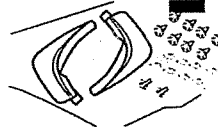
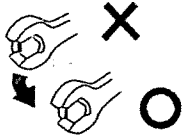

#### CAUTION

- Always use a torque wrench when tightening bolts and tighten to the specified torque. If tightened outside the specified torque. It could result in poor fit, part damage, or other damage.
- The splash guard (Front) is made of hard plastic. Handle it with care, as it may be deformed or discolored if it contacts solvents such as paint thinner or comes close to flame.

#### NOTE

- Refer to the applicable Workshop Manual for removal and installation of vehicle parts. Not following the procedures for removal / installation in the Workshop Manual could result in an accident or vehicle malfunction.

#### 4. SPLASH GUARD (FRONT) INSTALLATION

1. Use a soft cloth dampened with IPA (isopropyl alcohol) to clean the surface of the vehicle where the mud flap (front) is to be installed.

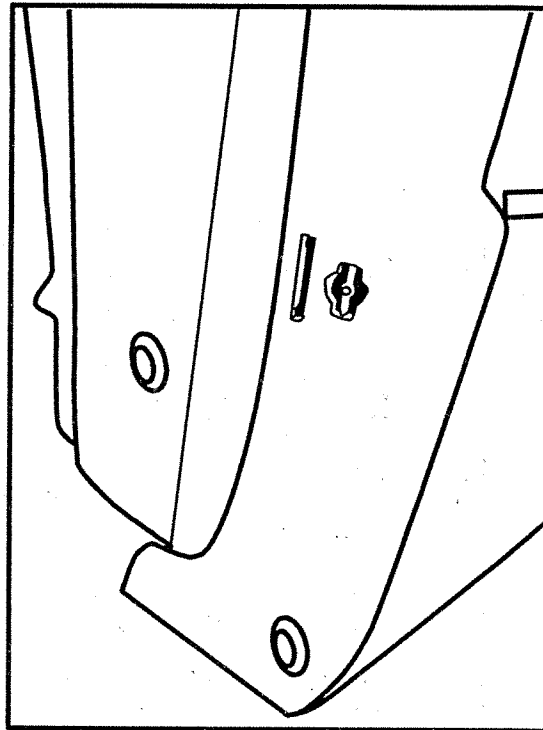

2. Cut out existing top, hour glass plastic tab using a nipper. Then cut the larger plastic tab next to it to create a shallow rectangular slot. Remove lower pull rivet.

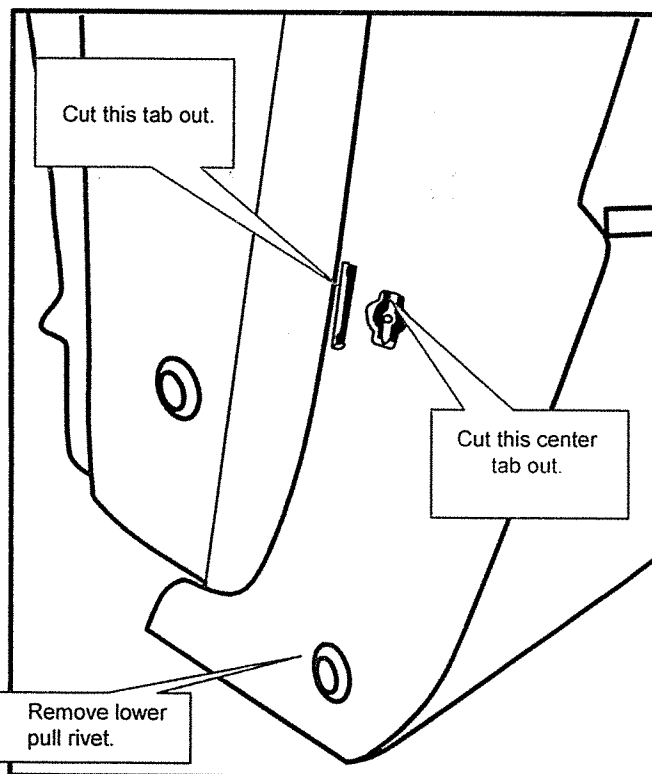

3. Align (2) kit clip nuts over the fender holes and install clip nuts.

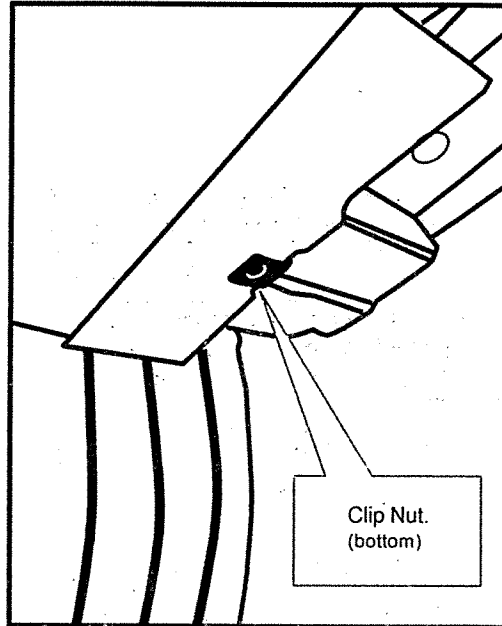
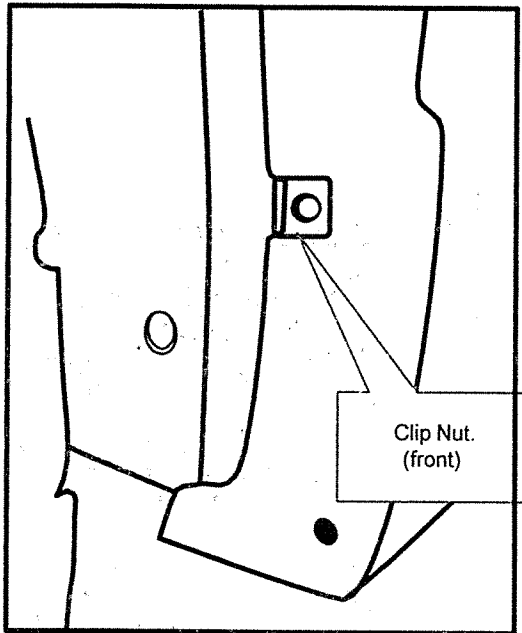

4. Loosely install deflector plate, splash guard, and bolt in the order shown below.

There are LH and RH deflector plates. Install on the correct side with the tape side facing up. Deflector plate has a scribe line that should approximately line up with the edge of the vehicle rocker panel. If it does not line up, make sure they are installed on the correct side.

Note: At this time do not peel tape backing off deflector plate. This is a dry fit only.

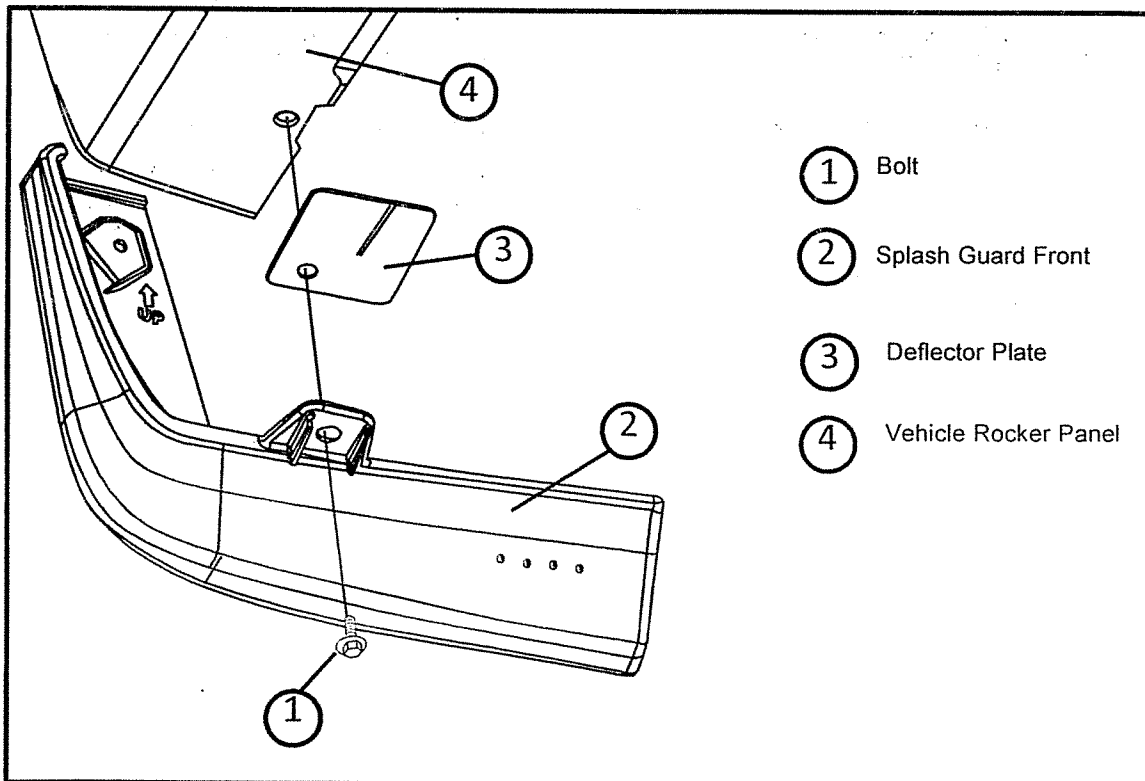

5. Loosely install (2) kit bolts. Use care to ensure bolts are not cross-threaded as damage could occur. Note the area where the double sided tape square on the deflector plate contacts the body panel.

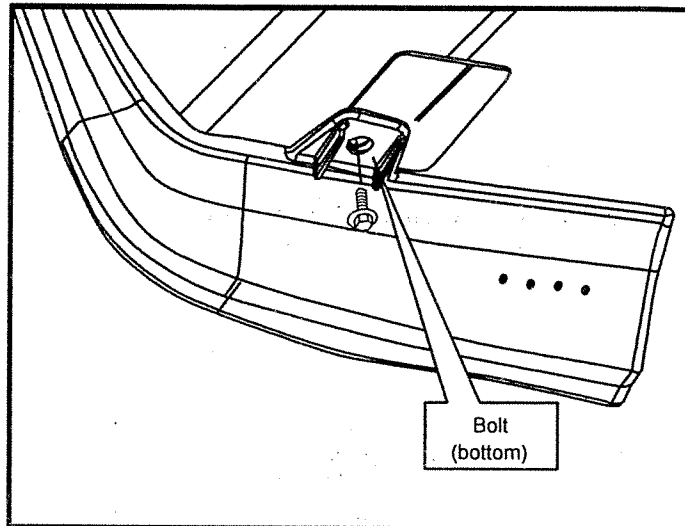
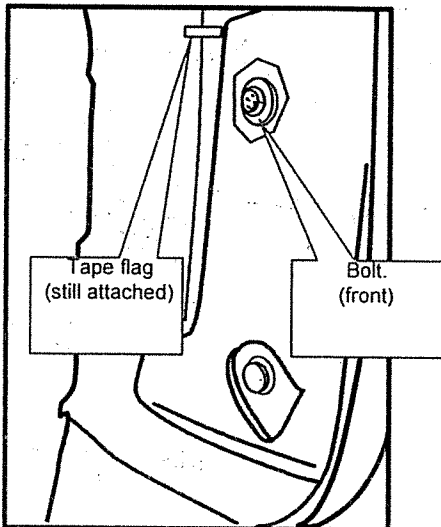

6. Insert pull-rievet loosely to ensure proper alignment of mud flap and wheel well. Press the mud flap (front) to the over fender installation area to ensure there are no gaps.

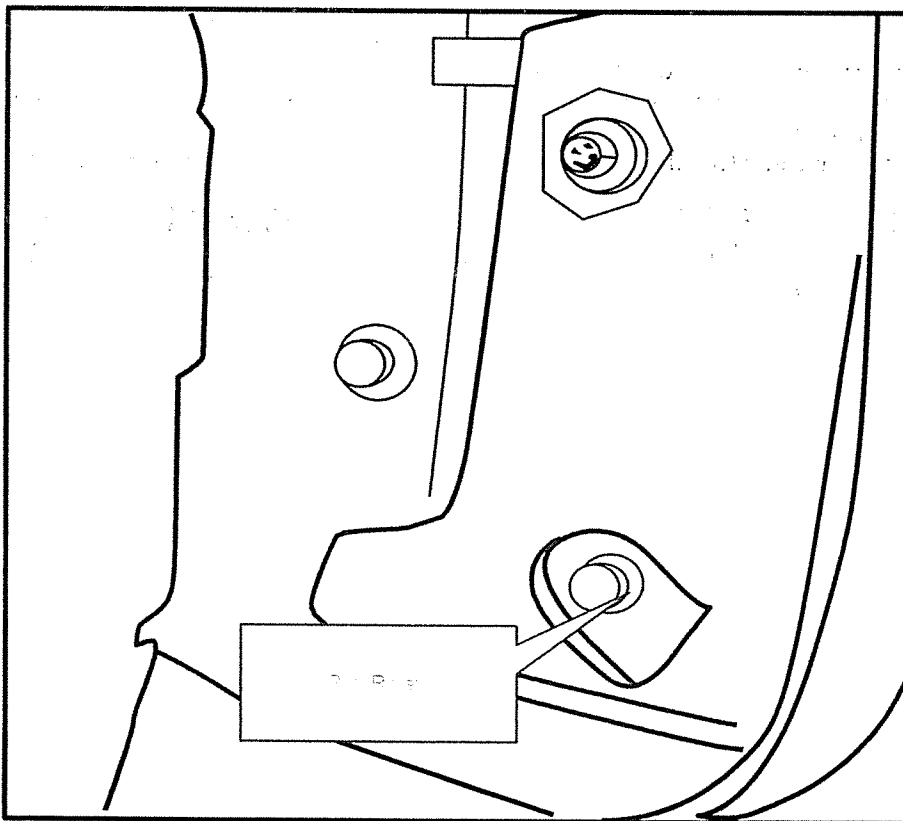

7. Mark the deflector plate location with pieces of masking tape. Remove bottom bolt and slide out deflector plate.

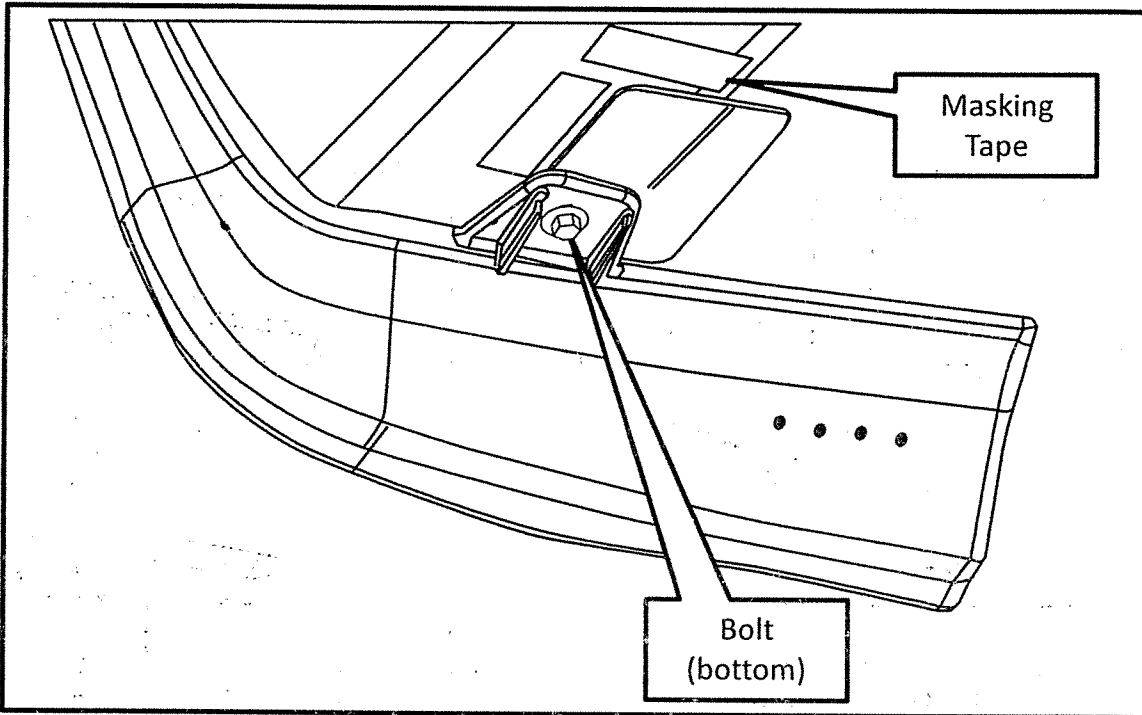

8. Clean the area where the double sided tape square on the deflector plate contacts the body panel with alcohol wipe. Let area dry then apply adhesive promoter. Allow adhesive promoter dry for 30 seconds. Slide the deflector plate back into correct position and loosely install bottom bolt. Make sure the bolt threads into the clip nut. Remove tape backing on deflector plate and press deflector plate firmly onto the rocker panel to adhere the double sided tape. Remove masking tape.

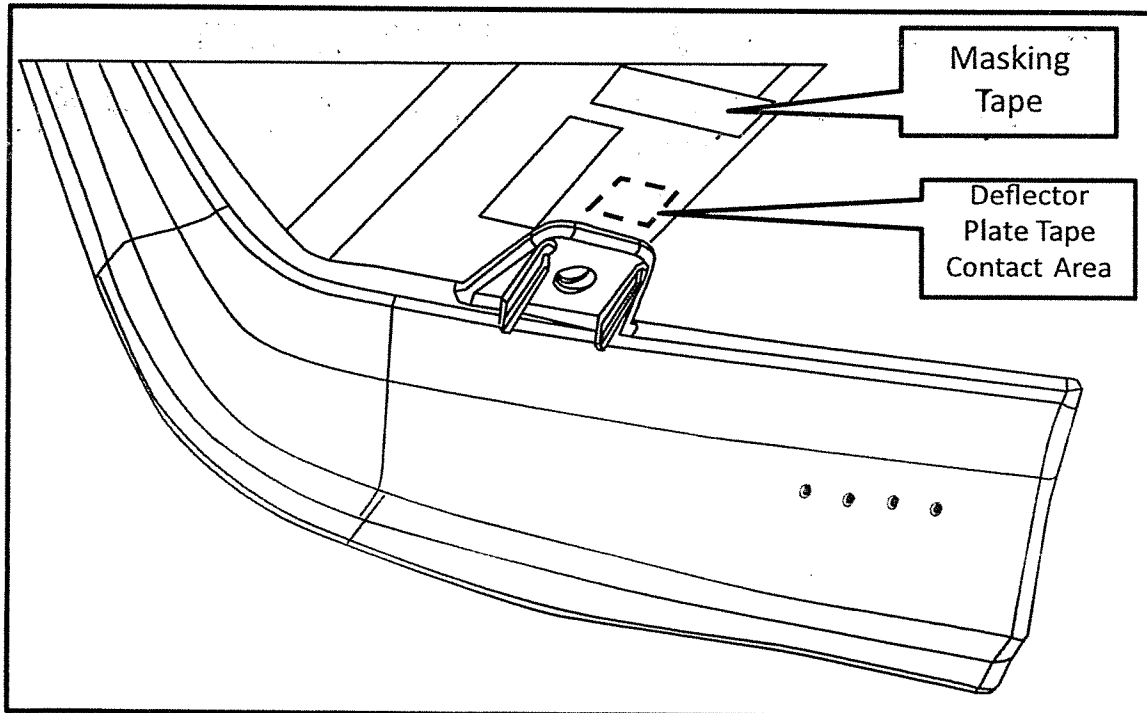

9. Remove pull-rievet, remove flag from the double-sided tape, and press part securely to vehicle.

10. Apply sufficient pressure to the double-sided tape from the exterior side of the mud flap (front)

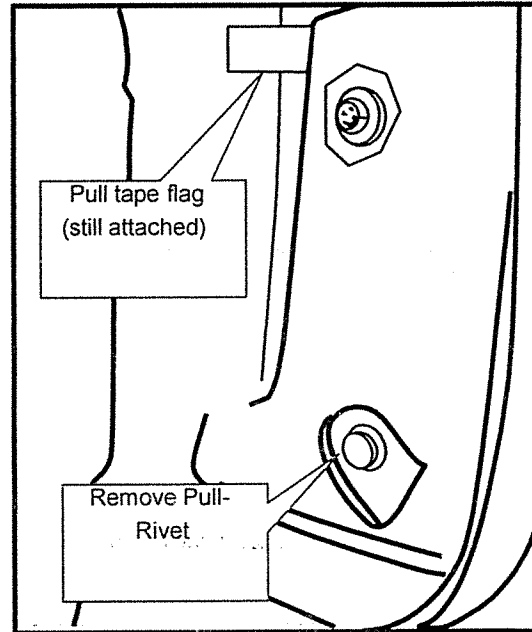

11. Re-install pull-rievet and torque bolts in order shown in the figure on the left while pressing the splash guard against the over fender.

NOTE: Ensure hole in the inner fender aligns with the vehicle sheet metal so that the pull rivet can be fully installed.

Tightening Torque: Bolt 0.8-1.2N\*m (8.2-12.2kgf\*cm \* 7.1-10.6in\*lbf

Repeat all steps to install splash guard (front) on other side of vehicle.

**CAUTION**

- Make sure the bolt is tightened securely. Make sure to tighten to the specified torque. If tightened outside the specified torque the splash guard (front) could be damaged or fall off.

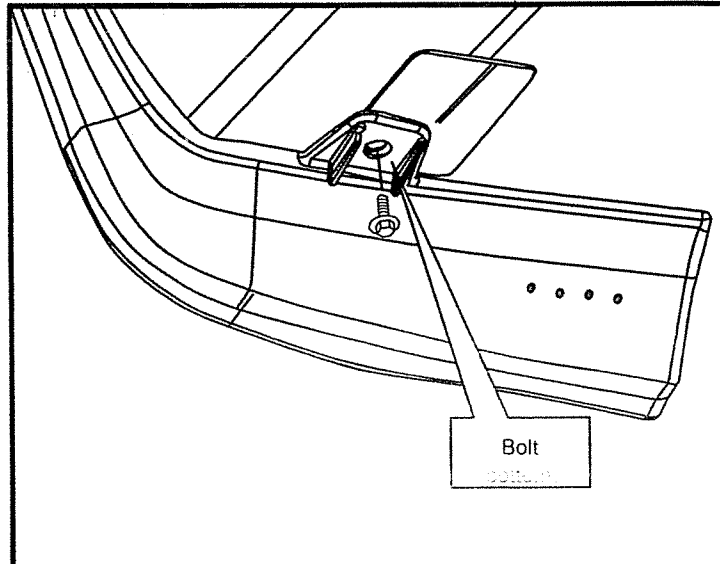
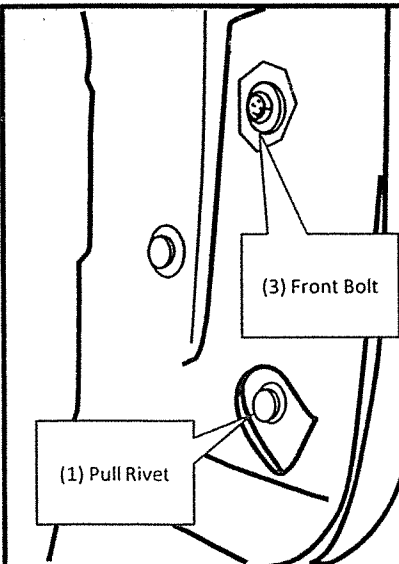



## 5. CONFIRMATION AFTER INSTALLATION

1. Be sure that there are no excessive gaps.

- If there are any gaps, loosen all the bolts and then retighten them in the order of top, middle, and bottom while pressing the splash guard (front) against the vehicle.

2. Be sure that all bolts are securely tightened.

## 6. SPLASH GUARDS (FRONT) PRECAUTIONS

### CAUTION

- If gasoline, engine coolant, or battery fluid adheres to the painted surface of the resin parts, it will cause discoloration, stains, or paint peeling. Wipe it off with a soft cloth immediately.
- Don't drive through an automatic car wash for 24 hours; it may damage the splash guard (front).
- Do not use car polish containing wax compounds. Otherwise, the surface could be damaged.
- If the vehicle height is lowered due to the vehicle being at maximum passenger or cargo capacity, decrease the vehicle speed when parking on a road shoulder or entering/leaving a road shoulder or bump. Otherwise, the splash guards (front) could be damaged.

**INSTALLATION  
INSPECTION  
SHEET**

**CX-9**

**SPLASH GUARD (FRONT)**

SEE COVER SHEET FOR P/N

**Inspection after installation**

- Inspect the installed / reinstalled parts for the following items.

Inspection Parts	Check Item (O)				
	Clearance/Fit	Scratches / Dirt	Installation / Engagement	Fastener, bolt tightening	Tape Attachment
Mud flap (Front)	o	o	o	o	o
Over fender	o	o	o	o	
Plate	o	o	o	o	o

Installation inspection sheet for SPLASH GUARD (Front)

Date				
VIN				
Approved		Checked		Person in charge

The term of validity for this sheet: 36 months