

GENUINE CARGO NET

INSTALLATION AND USER'S INSTRUCTIONS

Thank you for purchasing a genuine Mazda accessory.



Before removal and installation, be sure to thoroughly read these instructions.

Please read the contents of this booklet in order to properly install and use the cargo net.

Your safety depends on it.

Keep these instructions with your vehicle records for future reference.

WARNING

- There are several  **WARNING** and  **CAUTION** sections in this booklet concerning safety when installing or removing the cargo net. Always read and follow them in order to prevent injuries, accidents, and possible damage to the vehicle.

 **WARNING:** Indicates a situation in which serious injury or death could result if the warning is ignored.

 **CAUTION:** Indicates a situation in which bodily injury or damage to the vehicle could result if the caution is ignored.

- For areas indicating the tightening torque in this instruction manual, tighten to the specified torque using a torque wrench. For areas in which the tightening torque is indicated inside parentheses (), the tightening torque is indicated as a reference value, however tightening using a torque wrench is not necessary.
- Do not modify the cargo net.
- Do not install the cargo net in any way other than described in the following instructions.
- If in any doubt, please ask your Mazda dealer to install the accessory in order to prevent errors in installation.
- If you have any questions about the use of the accessory, ask your Mazda dealer for proper advice before using it.
- Mazda and its suppliers are not responsible for injuries, accidents, and damage to persons and property that arise from the failure of the dealer or installer to follow these instructions.
- To ensure safety and reliability of the work, installation, removal and disposal work done by an Authorized Mazda Dealership is recommended.
- Be careful not to lose removed parts, and be sure that they are kept free from scratches, grease or other dirt.

PART NAME: SIDE NET KIT
PART NUMBER: 0000-8K-N11
VEHICLE: MAZDA CX-9

NOTE

To the dealer

- Please turn over these instructions to the customer after installation.

To the customer

- Keep these instructions after installation. The instructions may be necessary for installing other optional parts or removal of this accessory.
- Should the vehicle or this accessory be resold, always leave these instructions with it for the next owner.



GENUINE ACCESSORIES
INSTALLATION INSTRUCTIONS

PART NUMBER:
0000-8K-N11

SIDE NET KIT

APPLICABLE MODELS:
2016 > MAZDA CX-9

PACKAGE CONTENTS

Cargo Net 2X
Installation Instructions
Inspection Sheet

T-Anchor Assembly

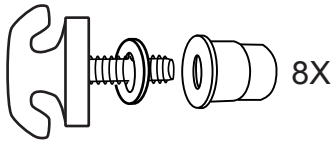

SPARE PARTS (available separately)
Hardware Kit (Part Number 0000-8K-N04)

TOOLS REQUIRED

Scissors
Plastic Trim Panel Remover
Grease Marker
Ratchet
Ratchet Extension
10mm socket
Masking Tape
Drill
1/4" Drill Bit (or 6mm)
Drill Stop

1 Preparation

1. Open lift gate.
2. Locate the mounting locations on the passenger side of the vehicle as indicated by the arrows (Fig. 1).

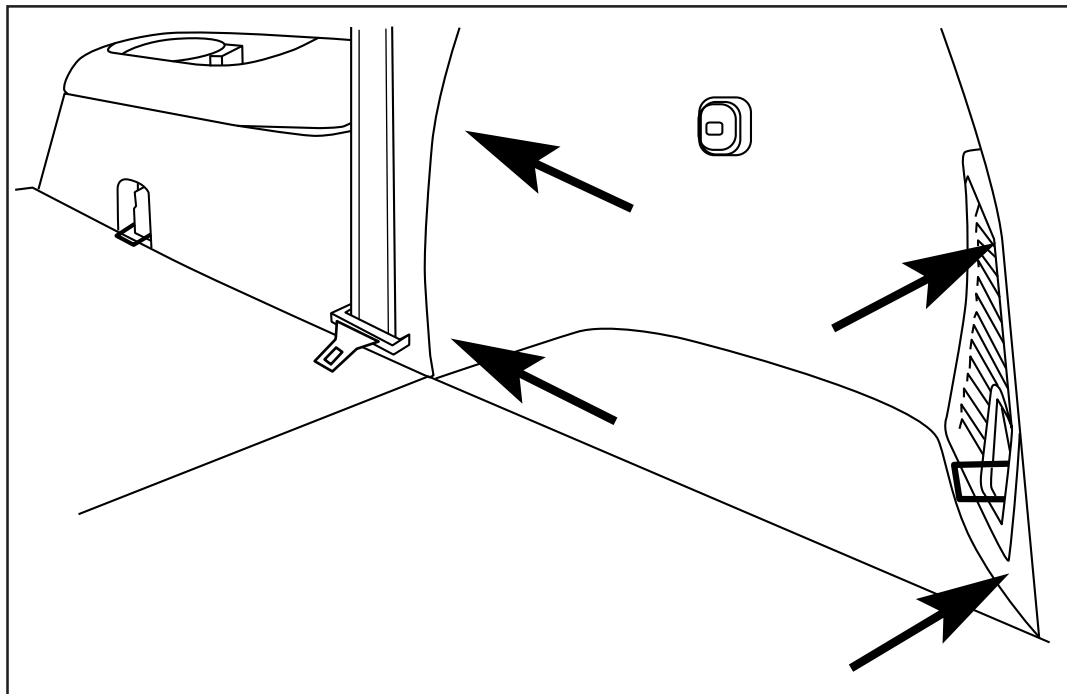

Fig. 1

2 Installation

3. Remove the carpeted trunk floor (Fig. 2).
4. Using the provided template labeled as "RIGHT SIDE", place and fold the template in place using masking tape (Fig. 3). Note: Before marking ensure the hole locations are located inboard of the edge of the side compartments. Holes should not be located on the main wall of the side trunk panel.
5. Using the grease marker, mark ALL locations that are to be drilled. Remove the template (Fig. 4).

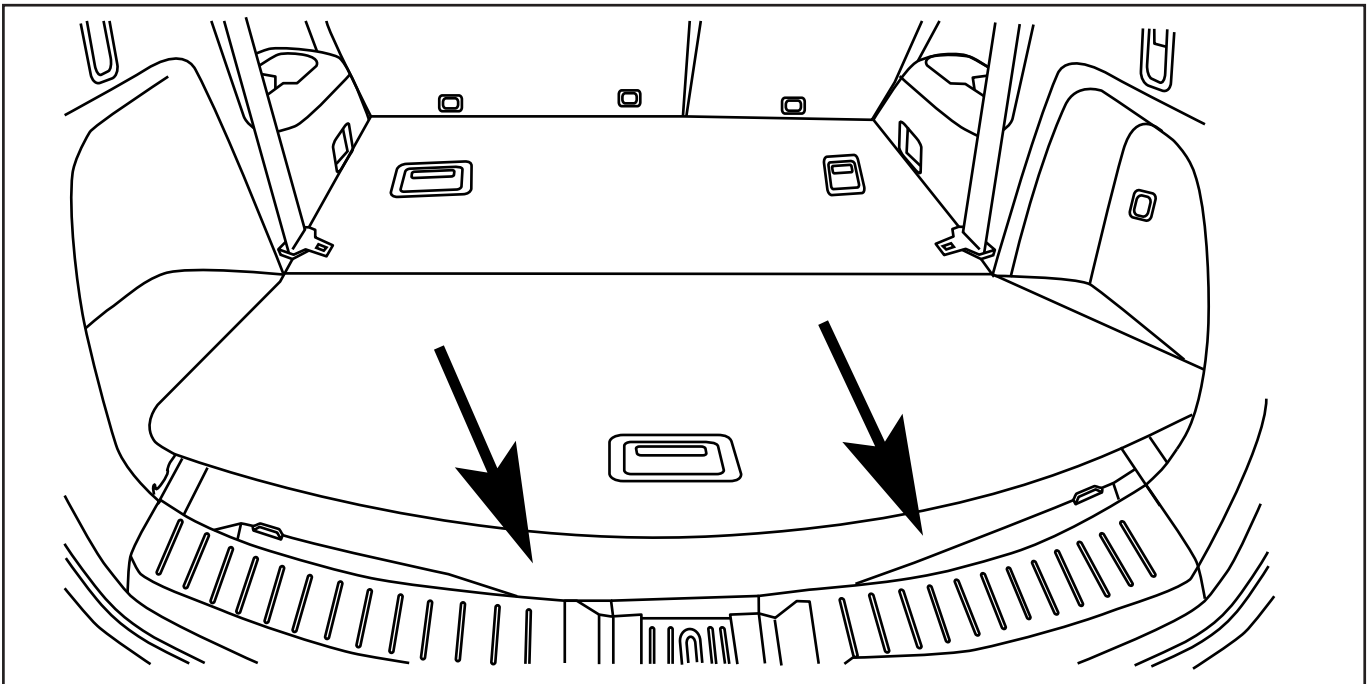

Fig. 2

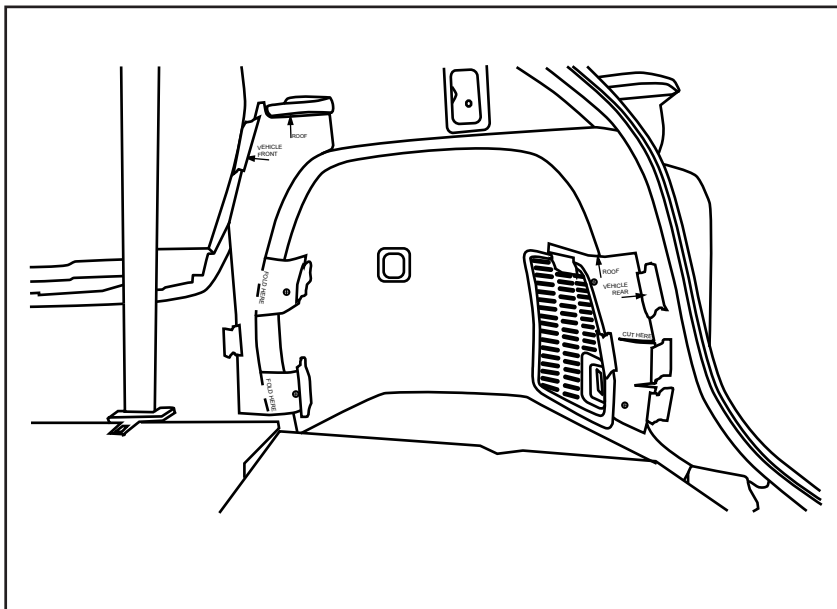

Fig. 3

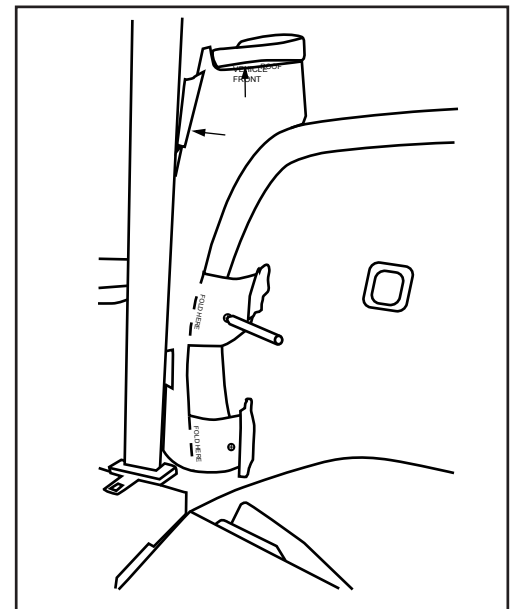

Fig. 4

2 Installation - (Continued)

6. Ensure ALL marked hole locations are inboard of the edge of the side compartments. The mark should not be located on the main wall of the side trunk panel (Fig. 5 Vehicle Front/Rear).
7. Using the 1/4" (or 6mm) drill bit and drill stop set at 1/2" (or 13mm), drill the hole locations (Fig. 6).
8. Remove the right side carpeted trunk floor (Fig. 7).

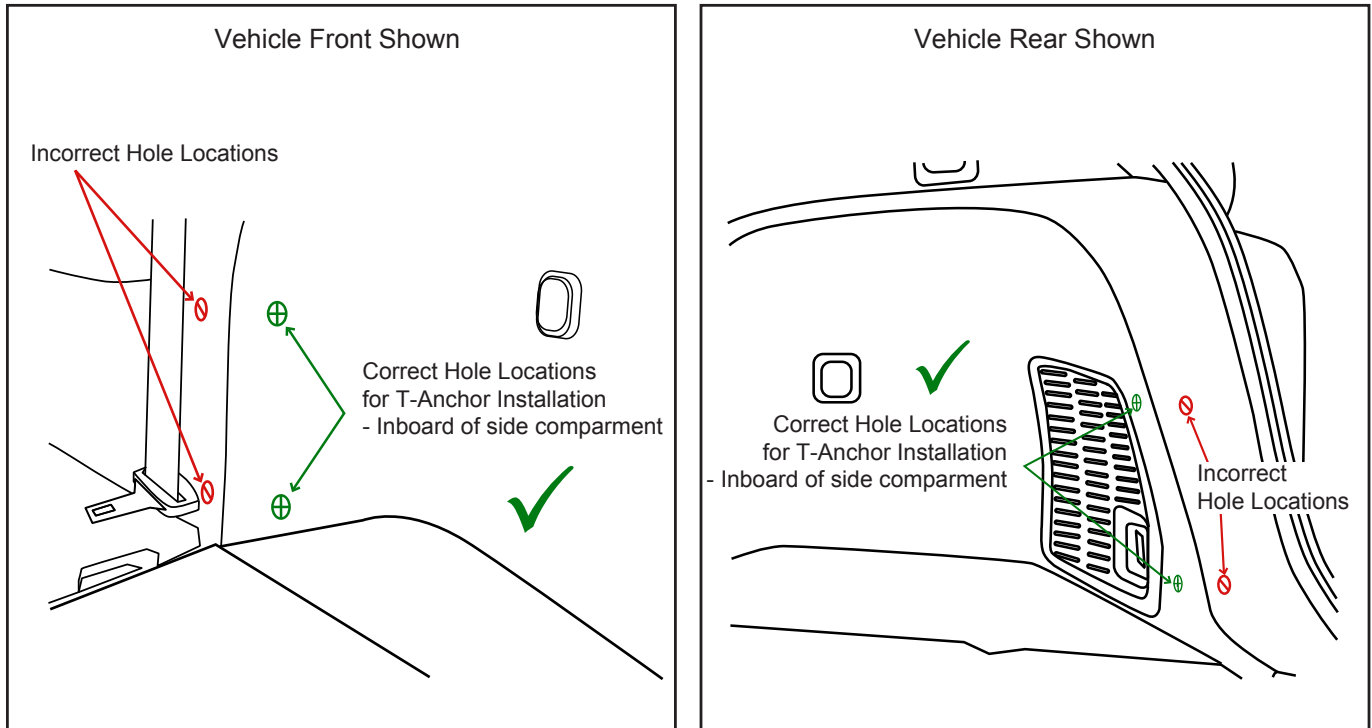

Fig. 5

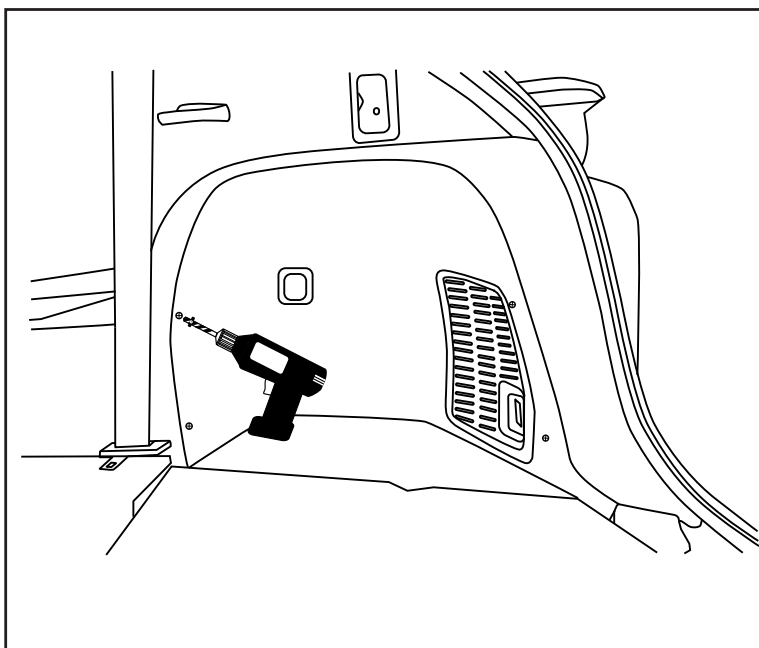

Fig. 6

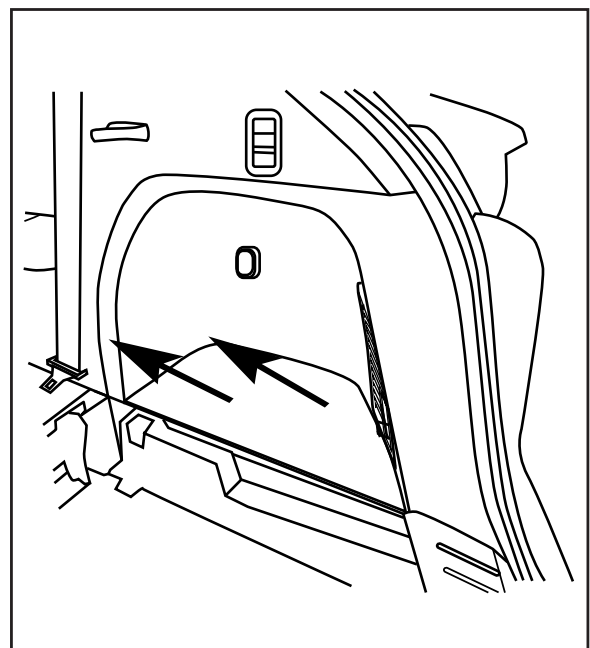

Fig. 7

2 Installation - (Continued)

9. Remove the lower tray (Fig. 8).
10. Remove the trunk floor (Fig. 9).
11. Remove the trunk sill plate by lifting up with your hands to disengage the clips (Fig. 10).
12. Remove the push-pin retainer from each side of the trunk sill plate (Fig. 11).

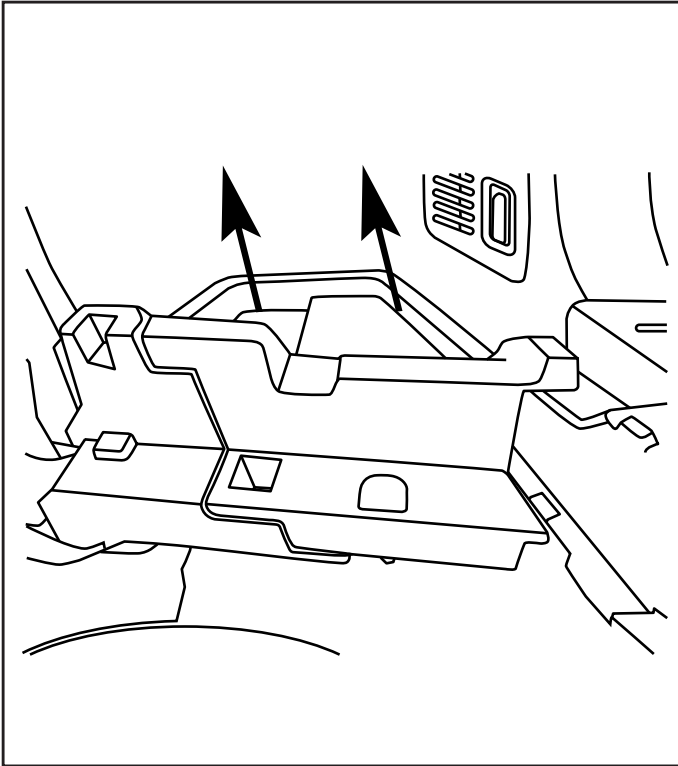

Fig. 8

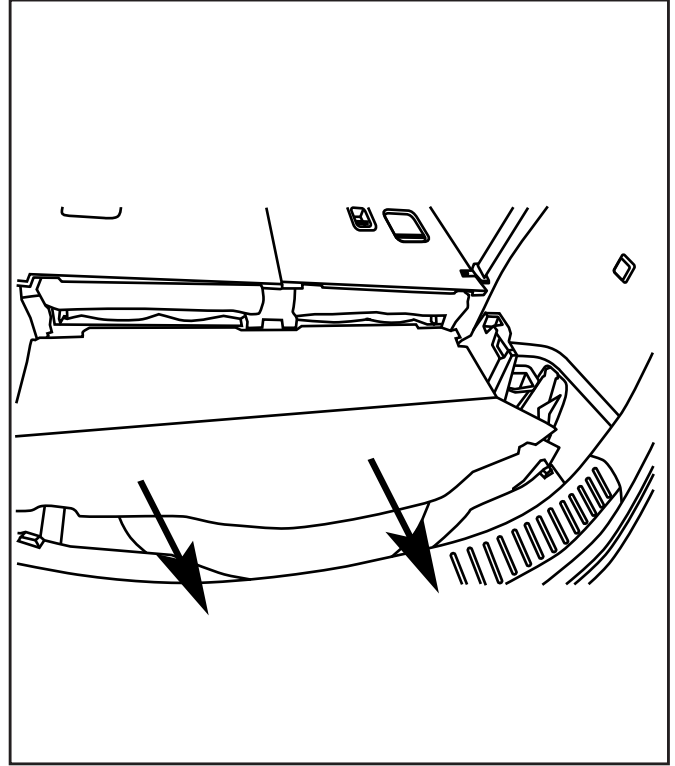

Fig. 9

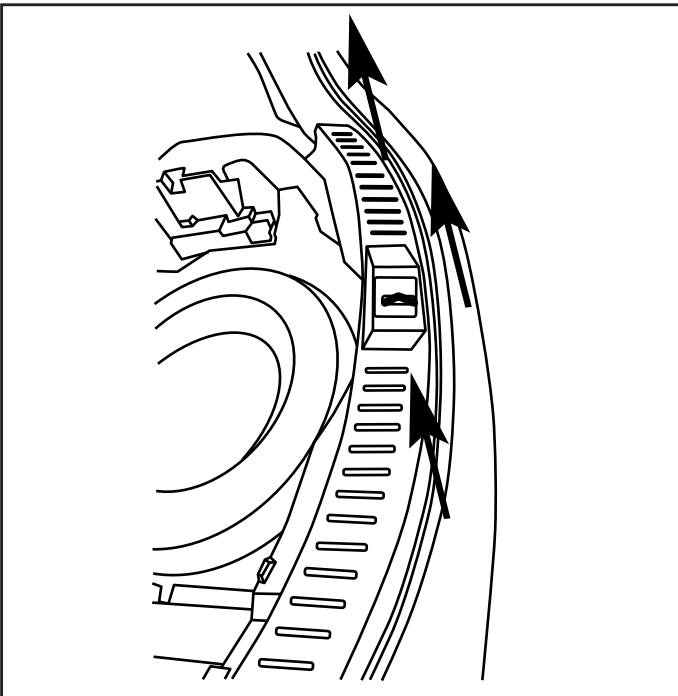

Fig. 10

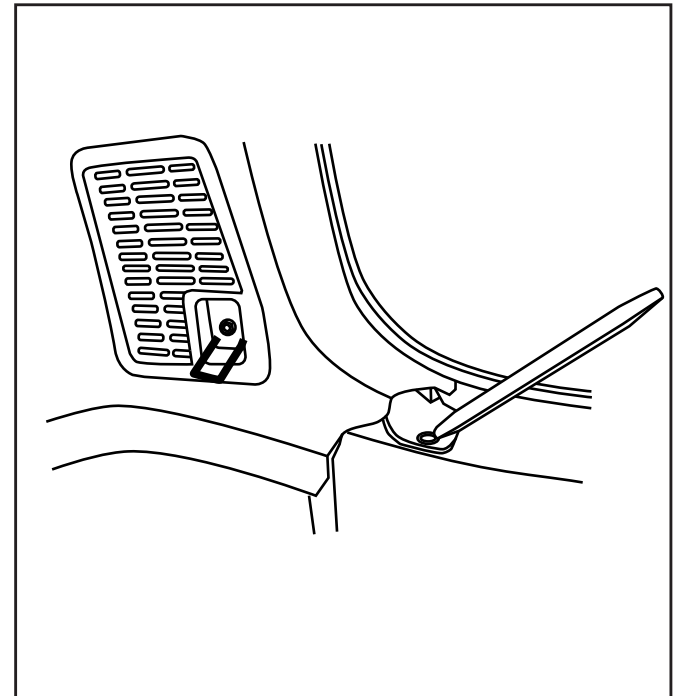

Fig. 11

2 Installation - (Continued)

13. Remove upper hook with ratchet and 10mm socket (Fig. 12).
14. Remove plastic cover from bottom D-ring (Fig. 13). Remove bolt with ratchet and 10mm socket (Fig. 14).
15. Gently disengage the Side Sill panel clips, by pulling towards the driver side. DO NOT disengage the entire Side Sill panel (Fig. 15).

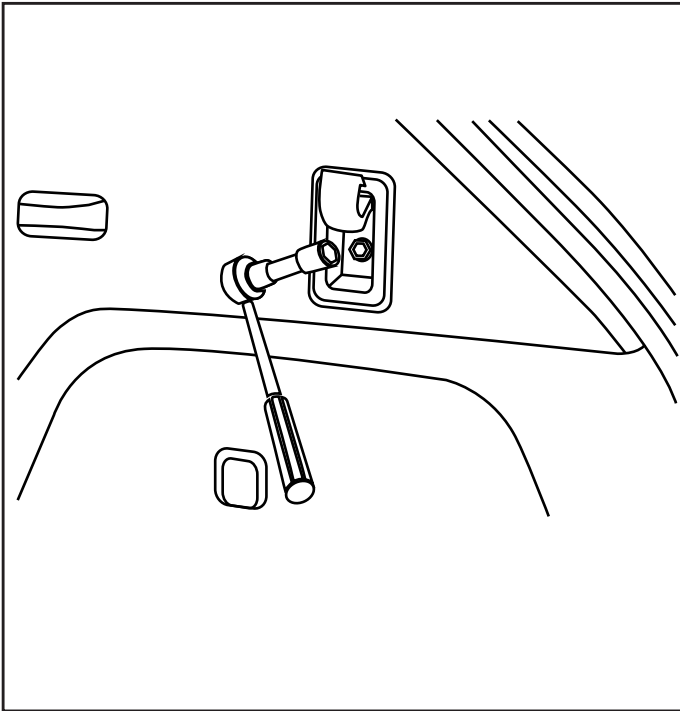

Fig. 12

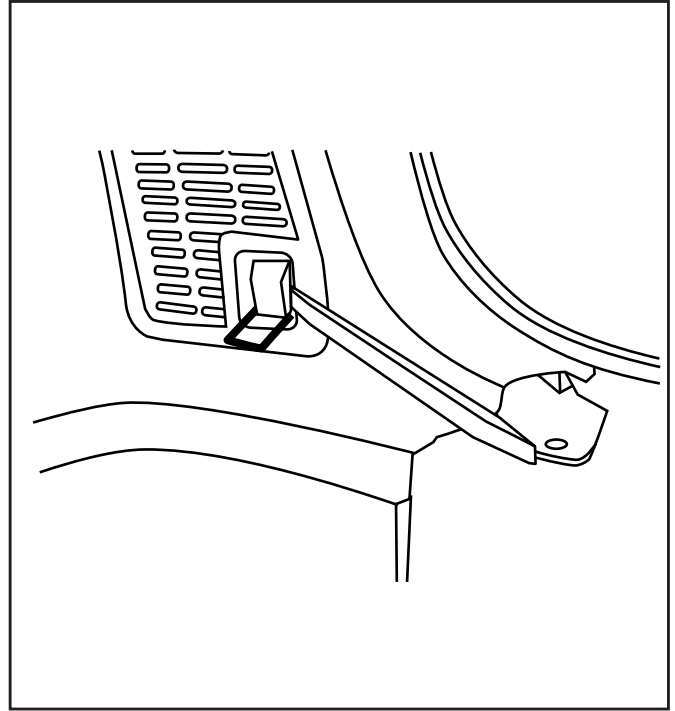

Fig. 13

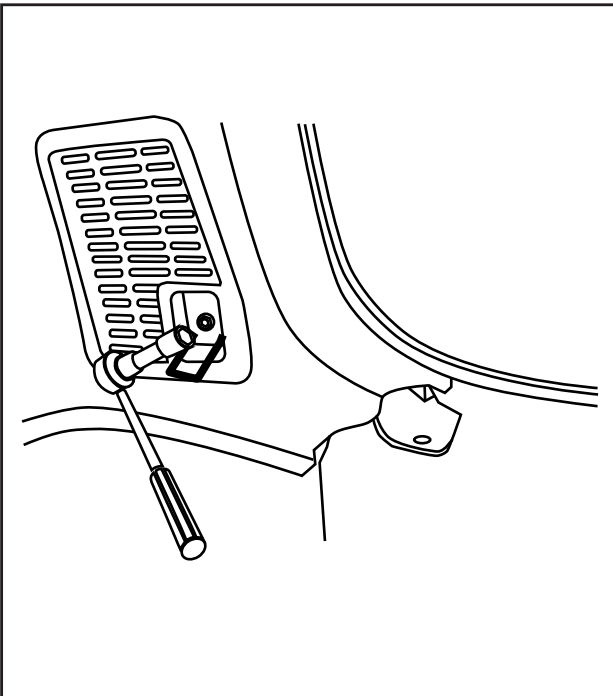

Fig. 14

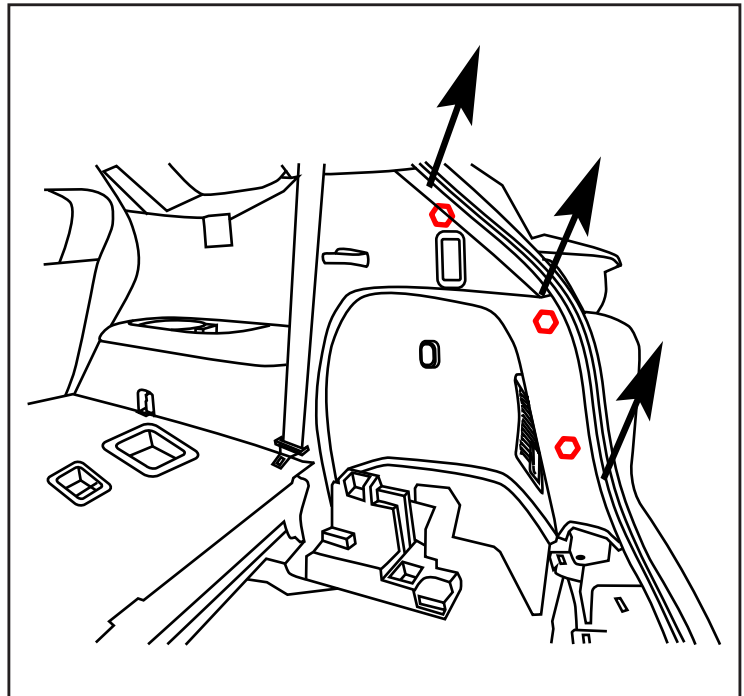

Fig. 15

2 Installation - (Continued)

16. Place Upper and Lower T-anchors with stud, through front hole opening (Fig. 16).
17. T-anchor with stud shown on backside of panel (Fig. 17-18).
18. Using the provided washer and rubber well nut, tighten the T-anchor until snug. The T-anchor should rest in a vertical position (Fig.20).

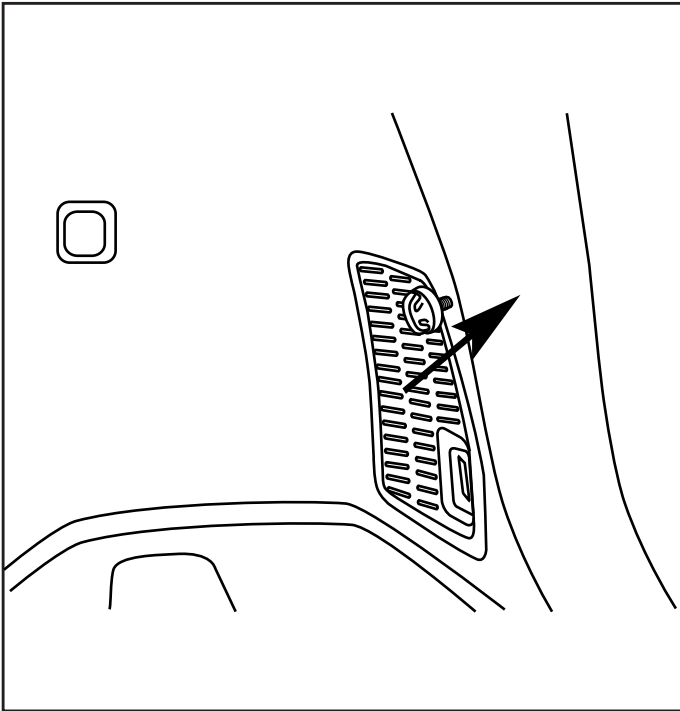

Fig. 16

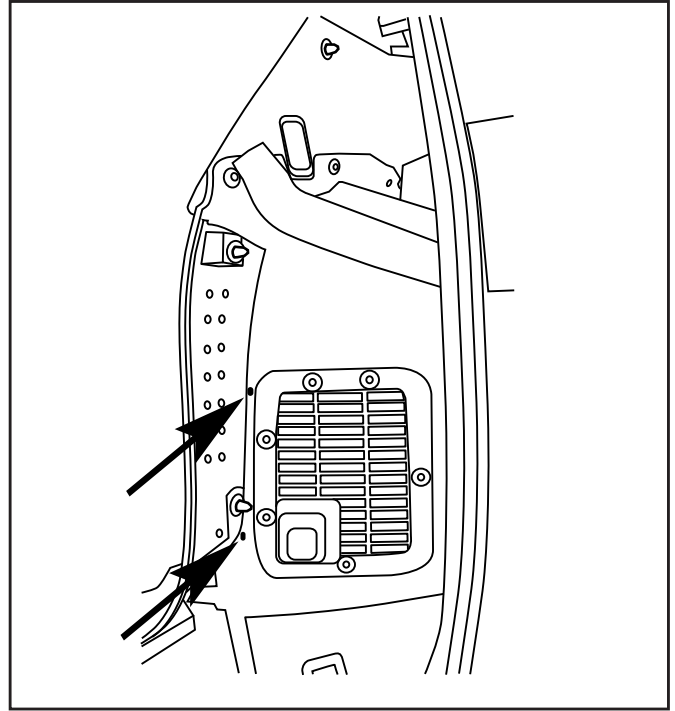

Fig. 17

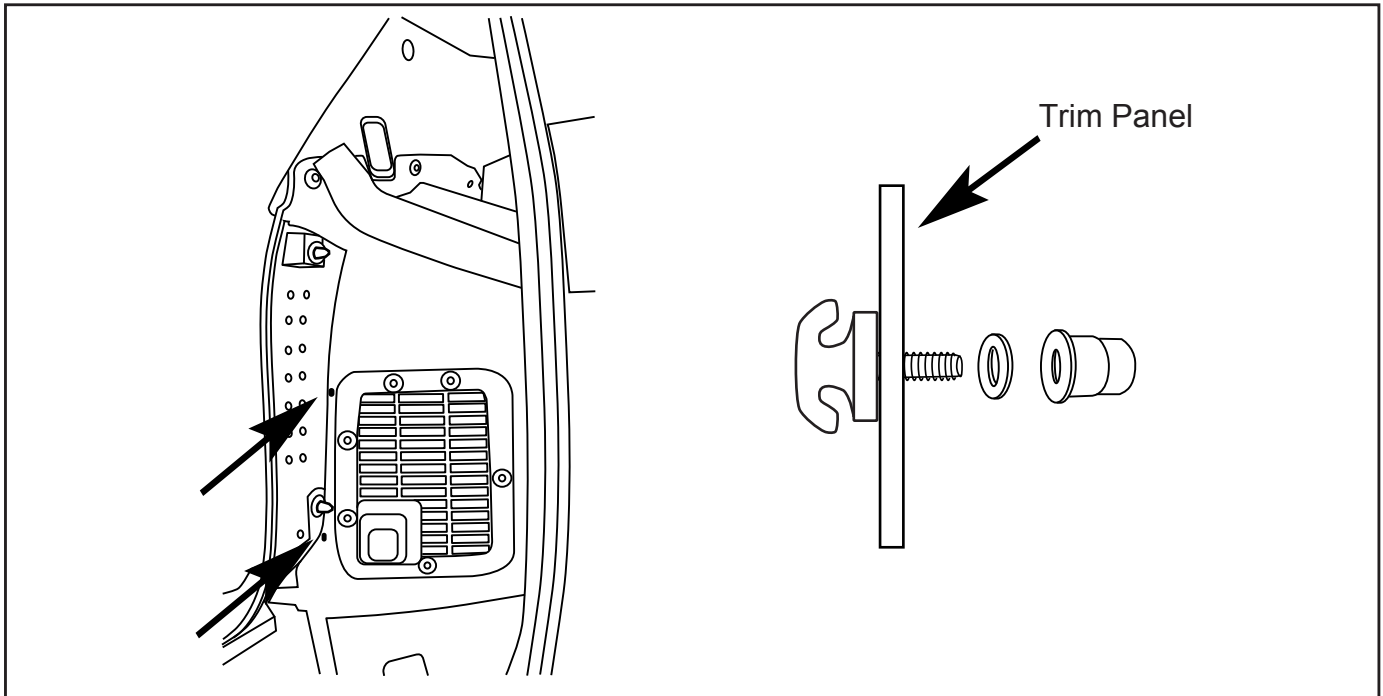

Fig. 18

2 Installation - (Continued)

19. When snug, the rubber well nut will expand as shown (Fig. 19).
20. Check that T-Anchor is in Vertical position. Perform the same steps, for the remaining hole locations (Fig. 20). Note: The 2 front anchor locations require the well nut and washer to be installed blind from behind interior panel. Do not drop washers or well nuts behind panel.
21. Re-install interior panel, upper hook, and bottom D-ring.
22. Install Side Cargo Net (Fig. 21)
23. Repeat all steps for driver side.
24. Reinstall all remaining trunk components.

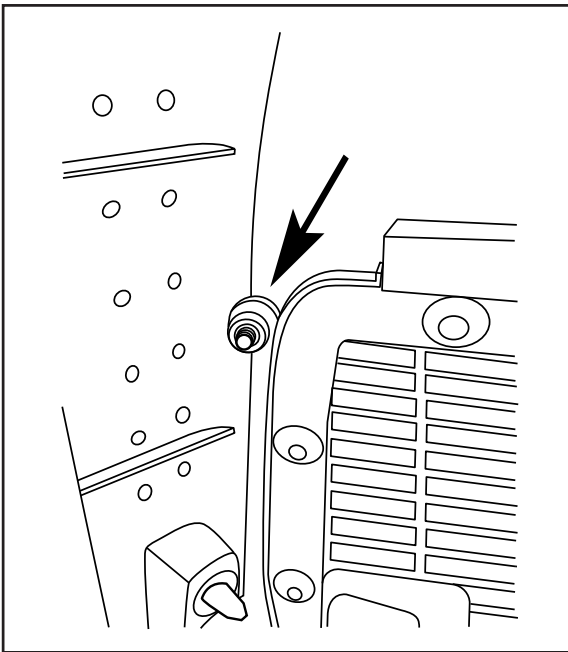

Fig. 19

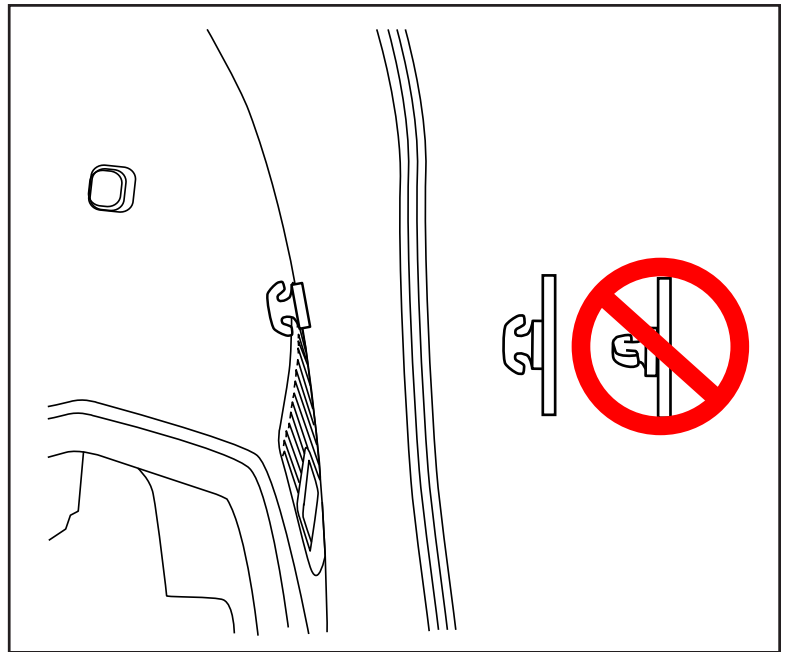

Fig. 20

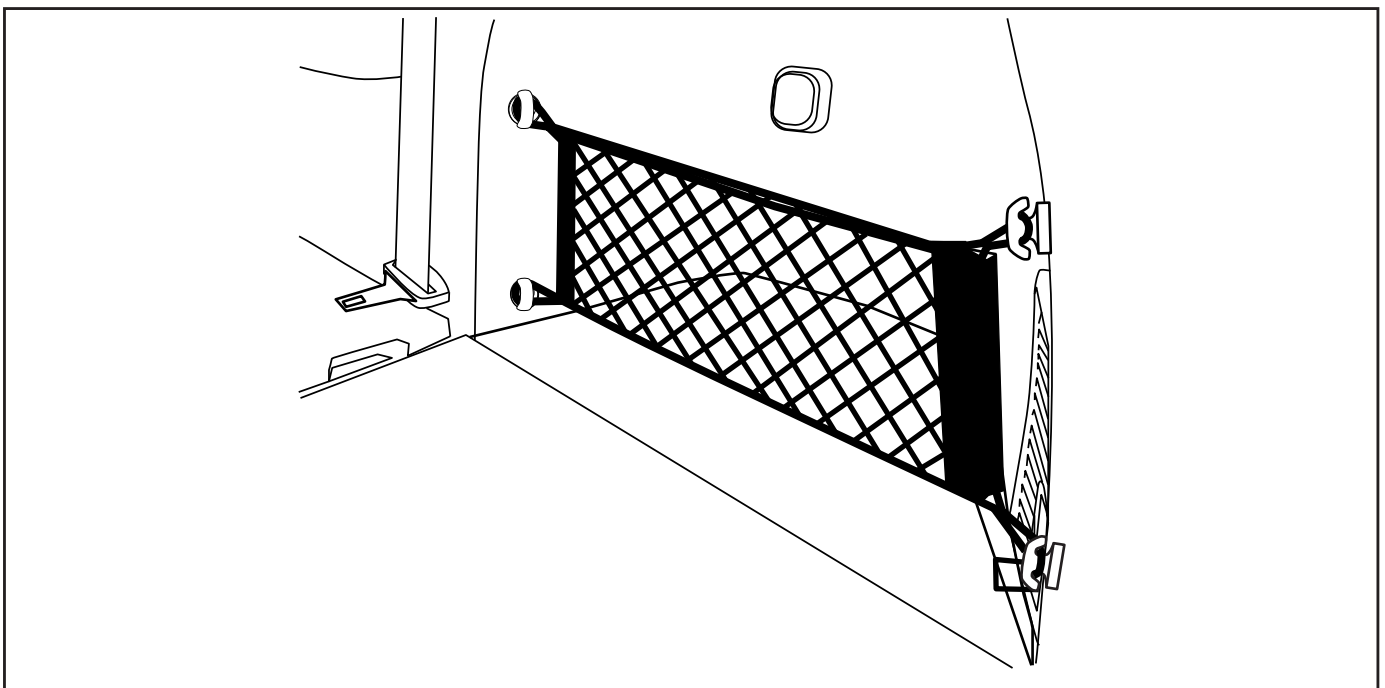

Fig. 21

3 Cleaning and Care

1. Hand wash using mild soap and warm water.
2. Do not machine wash.



WARNING: OBJECT(S) RESTRAINED NOT TO EXCEED 30 lbs. (13.6 kg)

SIDE NET KIT INSPECTION SHEET

- Inspect the installed/reinstalled parts for the following items.
- Inspection parts differ depending on the vehicle body style.

CX-9

Inspection Parts	Inspection Items (●)			
	Clearance/Fit	Scratches/Debris	Installation/Tightening/Engagement	Operation Check
Cargo Net	●		●	●
T-Anchor Assembly	●		●	●

● = Applicable

Date _____, _____, _____					
Vehicle. _____					
VIN. _____					
Approved		Checked		Person in charge	