



GENUINE ACCESSORIES
INSTALLATION INSTRUCTIONS

550-0681 Rev. AAA



PART NUMBER:

0000 8C R06(DIO) / 0000 89 R28(PIO)

APPLICABLE MODELS:

2017 > CX-5

REQUIRED COMPONENTS:

ITEM	QTY	DESCRIPTION	Usage Chart	Service Part Number
------	-----	-------------	-------------	---------------------

MIRROR ASSEMBLY:

1	1	Mirror Assembly w/ HomeLink®	①	0000 8C R08
---	---	------------------------------	---	-------------

INSTALLATION KIT:

2	1	SA Harness - 3 Conductor	①	0000 8C R07
3	10	Wire Ties	⑧	
4	1	Wire Cover	①	
5	1	A-Pillar Tether Clip (KB7W-68162A)	①	
6	3	Foam Tape	③	
7	3	Electro-Tap(wire connector)	③	
8	1	User Guide	①	
9	1*	Installation Instructions-English	①	
10	1*	Installation Instructions-French	①	N/A
11	1*	Installation Instructions-Spanish	①	N/A

*Installation Instructions not included in 0000 89 R28 or 0000 8C R07.

**Installation kit may have more components than necessary. Please refer to the chart above and the instructions for required components.

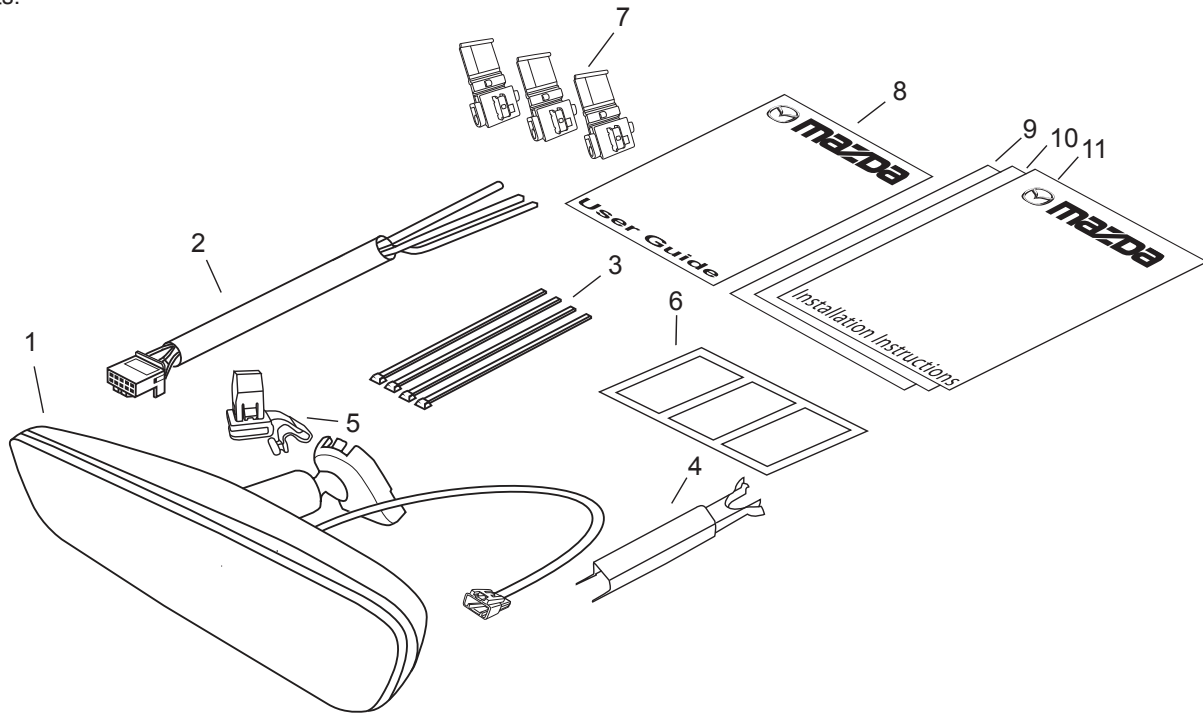

TOOLS REQUIRED:

HOMELINK® AND THE HOMELINK HOUSE® ARE REGISTERED TRADEMARKS OF GENTEX CORPORATION.

10mm Socket	Ratchet	Fiberstick	Needle Nose Pliers
2" Socket Extension	#T20 Torx Driver	Wire Cutters	Pliers
Clean Rag	4mm Flat Screwdriver	Pick Tool	

WIRE CODES

Two-color wires are indicated by a two-letter symbol. The first indicates the base color of the wire, the second indicates the color of the stripe. For example:

W/R = White wire with a red stripe

BR/Y = Brown wire with a yellow stripe

Symbol (Example):

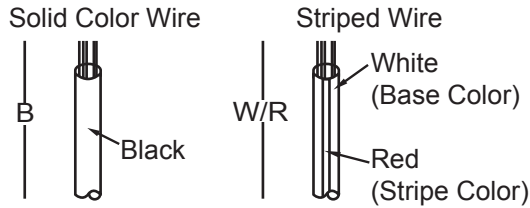

CONNECTOR DIAGRAMS

Connector diagrams show connectors on the harness side. The terminal indicates the view from the harness side.

Example:

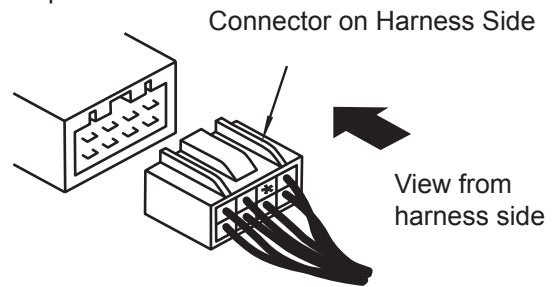

Unused terminals are indicated by "*"

DISCONNECTING CONNECTORS

When disconnecting the wires, grasp the connectors, not the wires.

Example:

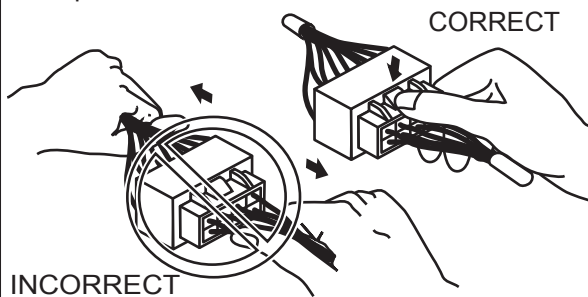

LOCKING CONNECTORS

When locking connectors, listen for a click, indicating they are securely locked.

Example:



WIRE TIE PROCEDURE

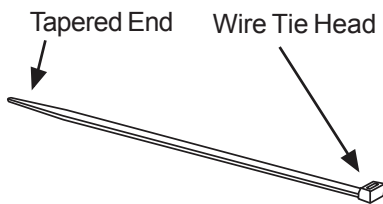

Wrap wire tie around the harness you wish to secure together.

Insert the Tapered End of the wire tie into the Wire Tie Head.

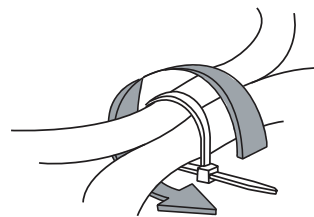

Pull the Tapered End through the Wire Tie Head until the wire tie is snug.

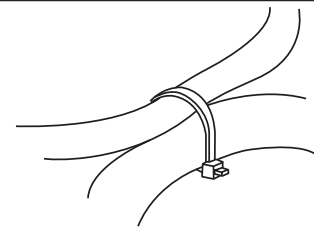

Trim wire tie end after tightening.

IDC WIRE TAP PROCEDURE

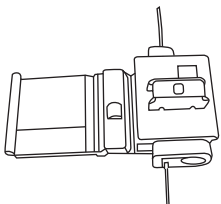

Place IDC on Vehicle Wire.

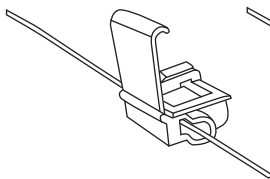

Close side of IDC.

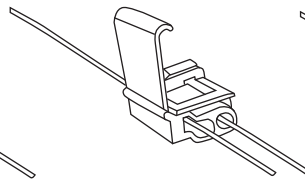

Insert EC Mirror Harness wire into IDC.

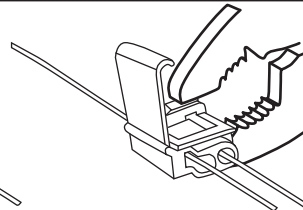

Crimp IDC metal tab over both wires until flush with top of IDC.

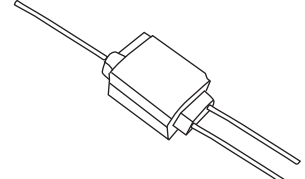

Close top of IDC.

INSTALLATION PRECAUTIONS / NOTES:

- If using fish wire, use caution to avoid damage to existing components.
- Do not place wire harness against objects with sharp edges that may cause electrical shorting.
- Verify that power harness path will not interfere with brake, clutch, emergency brake or air bag operation. Use wire ties to hold the wiring away from critical locations.

1 Preparation

1. Place kit components on a clear, padded surface and inspect for damage, defects, or missing components.
2. Record customer's programmed Radio - AM/FM/SAT stations and trip computer (if applicable).
3. Disconnect negative battery terminal.
 - a) Using 10mm socket, remove negative battery terminal. (Fig. 1-1)
4. Remove driver-side door seal.
 - a) Pull back past top of A-pillar trim. (Fig. 1-2)

5. Remove driver-side A-pillar trim.

NOTE

Do not use excessive force. A-pillar could be damaged.

- a) Pull out the top portion of A-pillar trim towards passenger-side of vehicle until A-pillar push-pin connector is extended approximately 1½". (Fig. 1-3)

NOTE

A-pillar connector will remain attached to vehicle body. (Fig. 1-3)

- b) Remove A-pillar push-pin connector from A-pillar trim. It is recommended to use your finger to slide A-pillar push-pin up off of A-pillar trim. (Fig. 1-3)

- c) After A-pillar trim is detached from connector, pull firmly to detach lower clips.

NOTE

For Vehicles equipped with speaker in a-pillar

- d) Detach speaker wire in lower portion of A-pillar by depressing connector clip and gently pulling away from speaker. (Fig. 1-4)

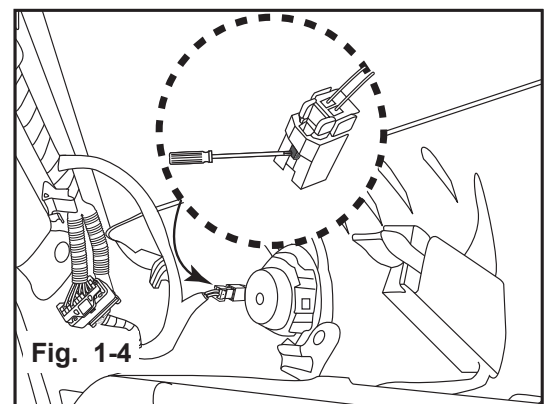
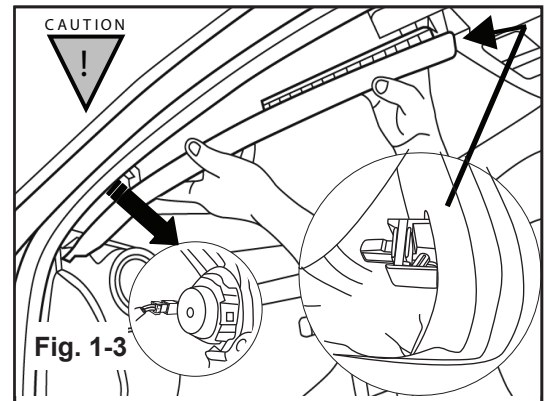
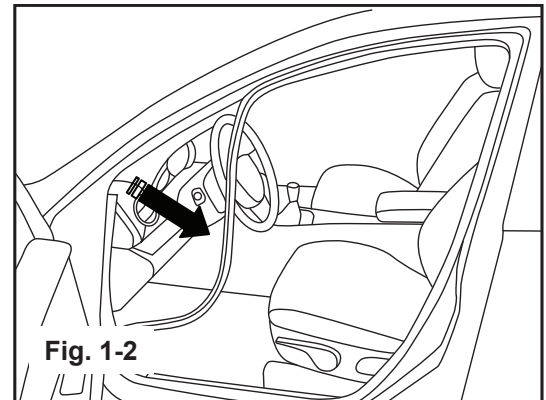
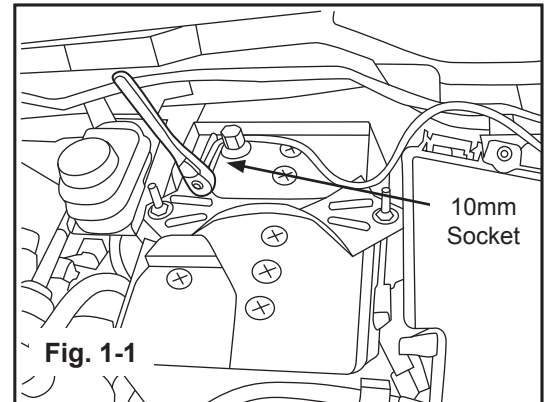

- e) Remove portion of a-pillar clip attached to the vehicle body by moving the hook in the direction of arrows (1) and (2) using a flathead screwdriver and detach it from the A-pillar inner panel. (Fig. 1-5)
- f) Remove the grommet in the direction of the arrow (3). (Fig. 1-5)
- g) Gently remove A-pillar trim by lifting upward.

NOTE

! A-pillar connector must be replaced with the supplied tether clip.

- h) Install new supplied A-pillar tether clip into A-pillar before proceeding. (Fig. 1-6)

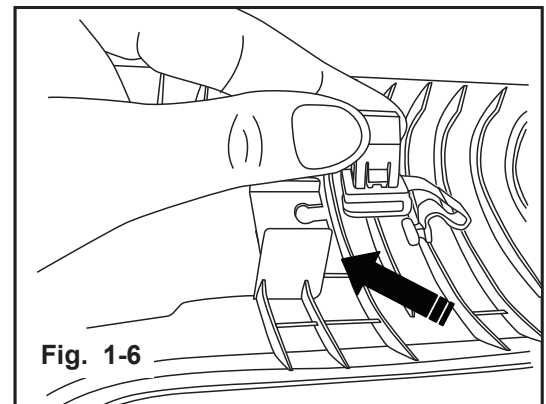
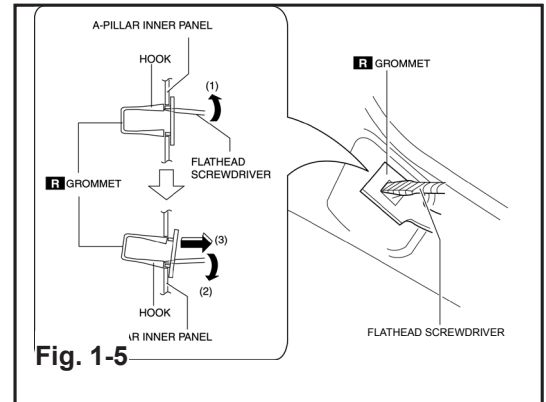

6. Remove OE Mirror.

- a) If vehicle is equipped with tech package, remove sensor cover by sliding the two halves of the cover outward. (Fig. 1-7)

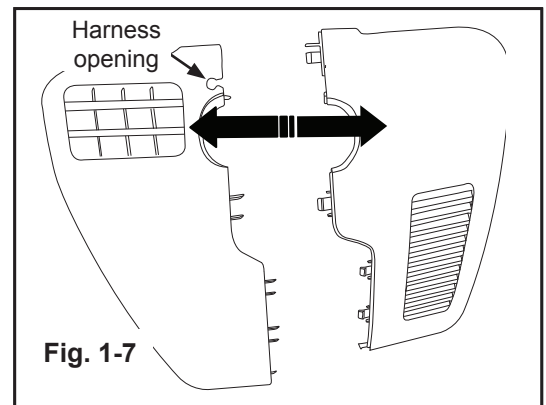

- b) Using a #T20 Torx, loosen the mirror mounting bracket screw. (Fig. 1-8)

- c) Grasp mirror mount at the tube, and gently pull upwards parallel to the windshield to carefully slide mirror off windshield button.

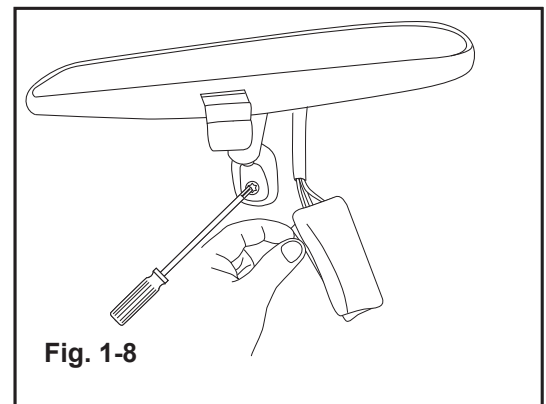

CAUTION

! DO NOT rotate mirror, turn mirror side to side, or pull mirror away from the windshield. Rotation, side to side movement, or pulling of mirror on windshield button could damage or break the windshield and button, requiring windshield replacement.

- d) If vehicle is equipped with auto dimming mirror prior to installation, wrap existing connector with 1 piece of foam tape and stow away in headliner.

2 EC Mirror Installation

1. Attach EC mirror.

- Hold the mirror head and slide the mount downwards as far as possible over the windshield button, until fully seated. (Fig. 2-1)
- Using a #T20 Torx, tighten the mirror mounting bracket screw to 15 lb-in.

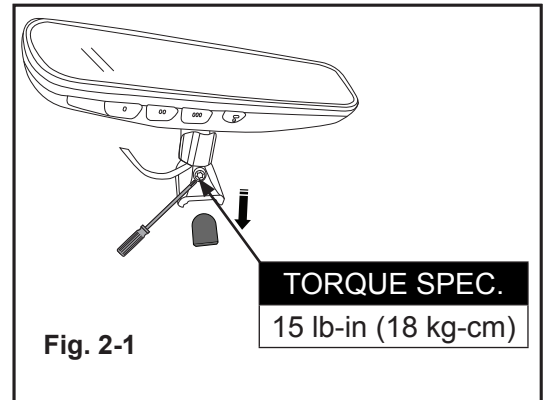

3 Route Mirror Harness to Vehicle Power

2. Plug installation harness connector into mirror connector.

- Plug installation harness connector into the mirror harness connector. (Fig. 3-1)
- Wrap two (2) pieces of foam tape around the connectors and tuck connectors into headliner.

NOTE

Ensure foam tape is wrapped completely around connectors to prevent rattling in overhead.

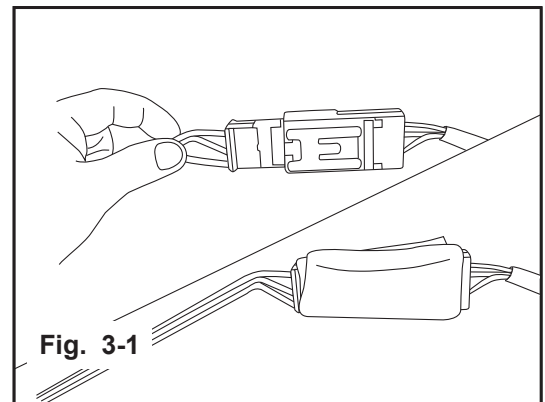

3. Route mirror harness from mirror to headliner.

- Route mirror harness into groove of wire cover and attach wire cover to mirror base. (Fig. 3-2)
- For vehicles without sensor cover, slide upper portion of wire cover up to headliner so the "forks" are held by the headliner.

NOTE

Vehicles with sensor cover will not use wire cover provided in accessory kit. Harness will route through wire hole in vehicle sensor cover. (Fig 1-7)

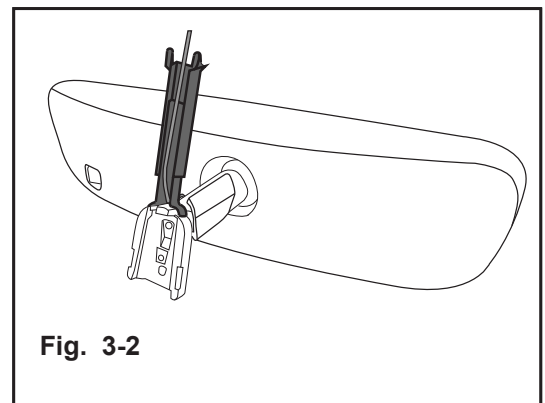

4. Remove sun visor clip.

- Using a taped flathead screw driver disengage locking tabs by pressing inward on both sides of the clip. (Fig. 3-3)

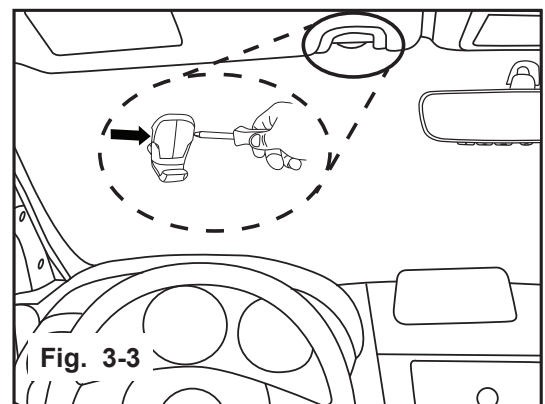

5. Route mirror harness to driver-side A-pillar.

- a) Route mirror harness between vehicle headliner and roof to top of driver-side A-pillar area. (Fig. 3-4)

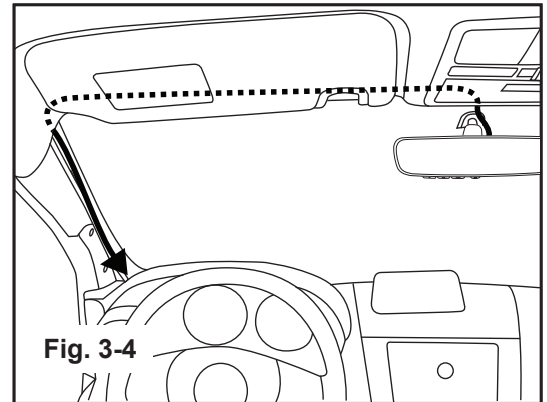

6. Route mirror harness down driver-side A-pillar.

For vehicles with OE Harness:

- a) Route mirror harness down A-pillar and secure to OE harness at the top of a-pillar with (1) wire tie while leaving the remainder of the harness loose as shown. (Fig. 3-5)
- b) See Wire Tie Procedure on Page 2 for detailed instructions and images of proper wire tie installation techniques.

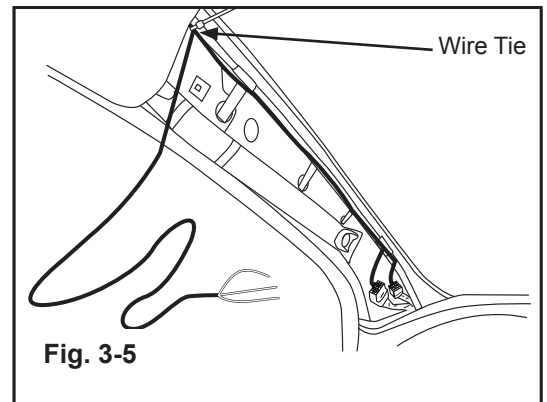

CAUTION

Ensure mirror harness does not interfere with airbag operation. Do not secure wire ties to air bag or sunroof drain tube.

4 Connect Mirror Harness Power and Ground

1. Locate the 24 pin connector at the bottom of the a-pillar. (Fig. 4-1)

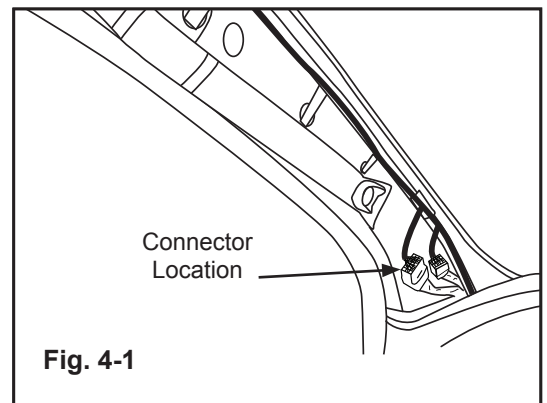

2. Prepare 24 pin connector for connection method.

- a) Using a pick tool, remove protective tape from corrugated tubing and slide away from the connector 1.5 inches. (Fig. 4-2)
- b) Remove protective tape from lower connector and slide away 1.5 inches from connector.
- c) Unplug 24 pin harness connectors by removing the female connector from the male connector.
- d) Using a screwdriver, disconnect the lower plug from the vehicle body by disengaging the connector snap and sliding upward.

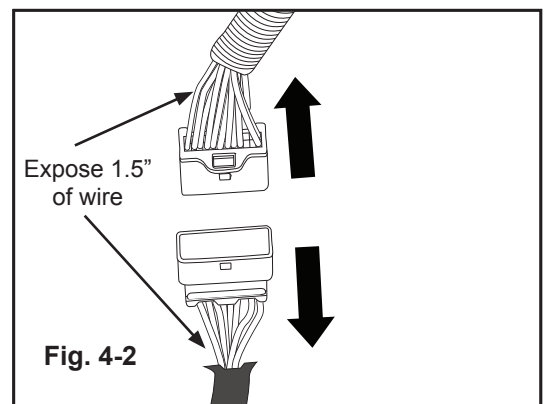

3. Connector EC Harness to Ground.

- a) Locate the **Black wire** in the location shown of the female (lower) 24-pin connector. (Fig. 4-3)

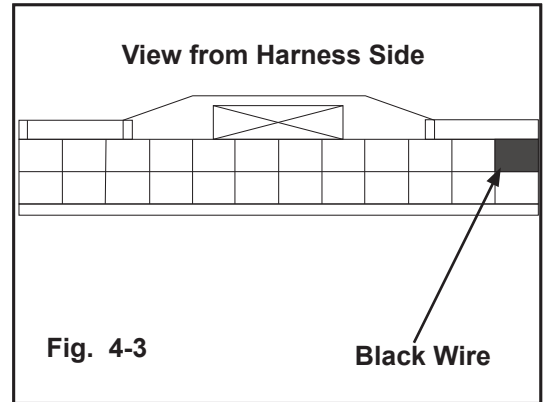

- b) Attach IDC connector to this **Black wire** of the lower 24-pin connector.
- c) Insert end of **Black wire** of the mirror harness into opening of IDC connector on the **Black wire**. (Fig. 4-4)
- d) Using Pliers, crimp IDC tab and then close plastic top.
- e) See **IDC Wire Tap Procedure on Page 2 for detailed instructions and images of proper wire tap installation techniques.**

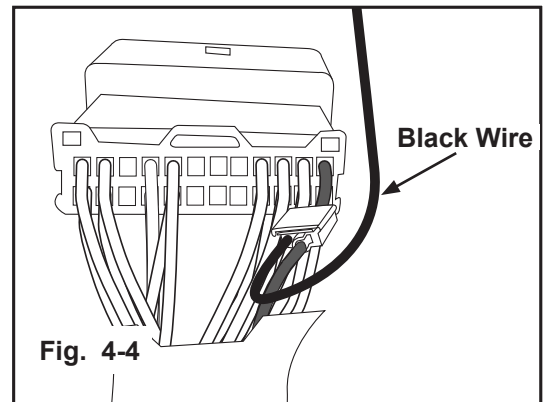

4. Connector EC Harness to +12V Ignition.

- a) Locate the **Violet wire** in the location shown of the female (lower) 24-pin connector. (Fig. 4-5)
- b) Attach IDC connector to this **Violet wire** of the 24-pin connector.

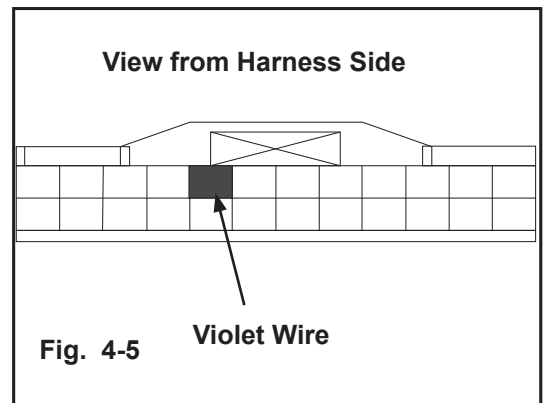

- c) Insert end of **Red wire** of the mirror harness into opening of IDC connector on the **Violet wire**. (Fig. 4-6)
- d) Using Pliers, crimp IDC tab and then close plastic top.
- e) See **IDC Wire Tap Procedure on Page 2 for detailed instructions and images of proper wire tap installation techniques.**

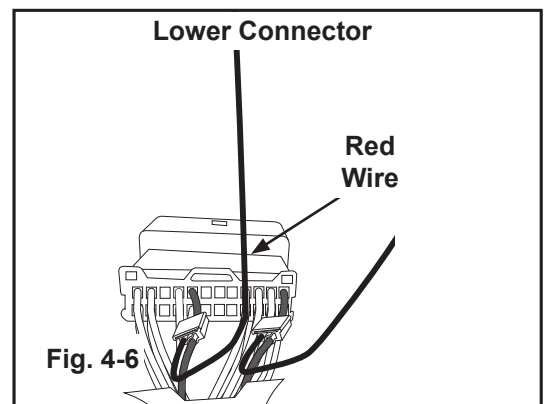

5. Connect EC harness to Battery.

- a) In the same 24-pin female connector, locate the **Brown wire** in the location shown. (Fig. 4-7)
- b) Attach IDC connector to this **Brown wire** of the 24-pin connector.

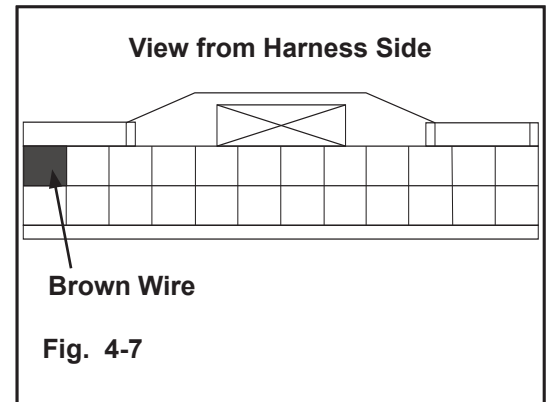

- c) Insert end of **Blue wire** of the mirror harness into opening of IDC connector on the **Brown wire**. (Fig. 4-8)
- d) Using Pliers, crimp IDC tab and then close plastic top.
- e) See **IDC Wire Tap Procedure on Page 2** for detailed instructions and images of proper wire tap installation techniques.
- f) Wrap one piece of foam tape around IDC connectors.

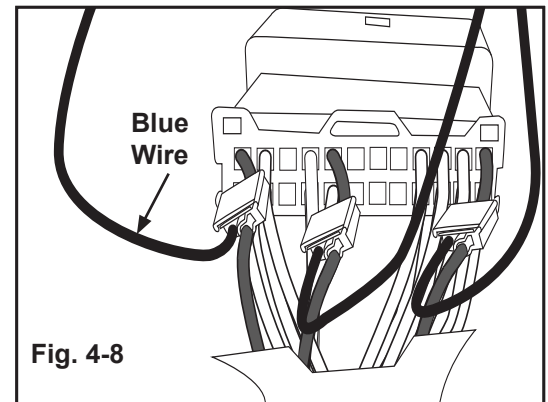

5 Secure Remaining EC Harness Wires

1. **Bundle excess EC harness wires with wire ties.**
 - a) Bundle excess EC harness wires with (5) additional wire ties. (Fig. 5-1)
 - b) See **Wire Tie Procedure on Page 2** for detailed instructions and images of proper wire tie installation techniques.

CAUTION

Ensure mirror harness does not interfere with airbag operation. Do not secure wire ties to air bag or sunroof drain tube.

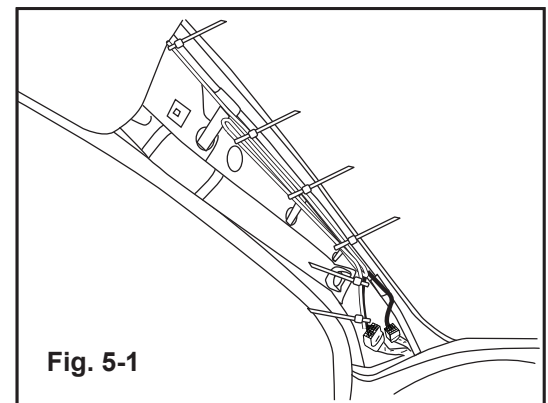

6 Testing

1. Reconnect negative battery cable.
2. Turn the ignition switch to ON.
3. With the vehicle in a fairly well-lit area, perform the following:
 - a) Verify the left 3 button images are faintly lit with white back-lighting.
 - b) To make sure the auto-dimming feature is on, verify that the power button, located the center button is illuminated. If it is not on, push the "☺" button to turn the green LED on. (Fig. 6-1)

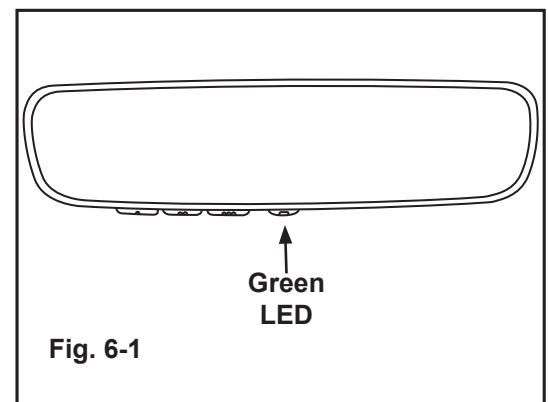

- c) Cover the forward looking photocell on the back of the mirror with a dark cloth or towel and in a few seconds the mirror will begin to darken. (Fig. 6-2)

- d) Remove the cover from the forward looking photocell and the mirror will begin to clear.

NOTE

Time to darken will vary with ambient light level.

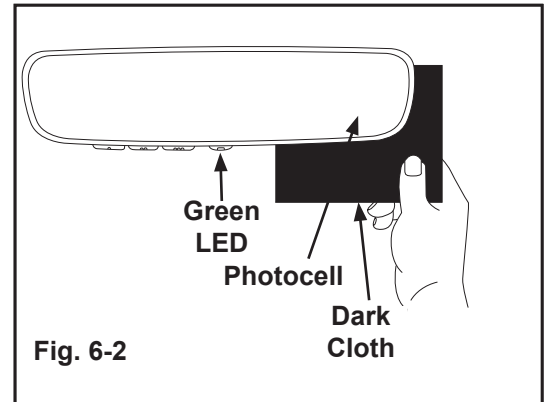

4. Turn the ignition key to the OFF position.
5. Push each HomeLink® button, one at a time, and verify that the HomeLink® indicator blinks orange. (Fig. 6-3)
6. Testing is now complete.

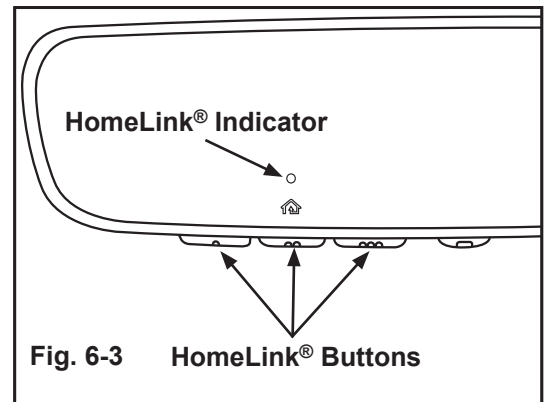

7 Installation of Removed Components

1. Trim excess off all wire ties.
2. Reinstall all trim in reverse order that is was removed.
3. Place User Guide in vehicle glove-box.
4. Remove fingerprints, smudges, etc. from mirror and verify each component for proper fit and function.

8 Inspection

Inspection Parts	Inspection Items (O)			
	Clearance / Fit	Scratches / Dirt / Harness Interference	Installation / Tightening / Engagement	Operation Check
Negative battery terminal			*1	
Driver-side Door Seal	O	O	O	
Driver-side A-pillar Trim	O	O	O	
EC mirror torx screw			*2	
EC harness connector			O	
EC mirror features:				
- auto-dimming				*3
- Homelink®				*4
User guide			*5	

O : Applicable

***1: Tightened to 4-6 N-m**

***2: Tightened to 15 lb-in (18 kg-cm)**

***3: Mirror dims (key must be in ON position).**

***4: Orange circle blinks through the glass when each button is pushed (test with key in the OFF position).**

***5: In vehicle glove-box.**

CAUTION**When the battery is disconnected, the DSC may stop operating.**

(The DSC OFF indicator will flash at this time, and the TCS/DSC operation indicator will illuminate.)

Carry out the following procedure to reactivate DSC:

1. Turn the ignition switch to "OFF" and then turn it back to "ON".
2. Turn the steering wheel clockwise as far as it will go, and then turn it back counterclockwise as far as it will go.
3. Check that the TCS/DSC operation indicator is turned off.
4. Turn the ignition switch to "OFF" and then turn it back to "ON".
5. Check that the TCS/DCS operation indicator is turned off. If the TCS/DSC operation indicator is still illuminated or the DSC indicator is not turned off when the ignition switch is turned back to "ON", contact your Mazda dealer.

CAUTION**If the battery is disconnected, the power windows may no longer fully open or fully close automatically.**

Carry out the following operation at driver seat first and passenger seat to restore normal operation:

1. Turn the ignition key to the "ON" position.
2. Press the power window switch to fully open the power windows.
3. Lift up the power window switch to fully close the power windows, and keep it pulled up for approximately 2 seconds.
4. Position the engine switch at "OFF", and then at "ON" again. When the function doesn't work after these procedures, please contact your Mazda dealer.

Verify the following:

1. B+ harness wire (pin 6 terminal side) is receiving +12V with ignition OFF and ON.
2. Switched harness wire (pin 1 terminal side) is receiving +12V with ignition ON and 0V with ignition OFF.
3. Ground wire (pin 2 terminal side) is securely attached.
4. Mirror harness is fully inserted into mirror.
5. Mirror harness is not pinched, cut or damaged.
6. Ensure IDC connectors are properly installed. Check to see that the blade in the connector did not miss either wire.

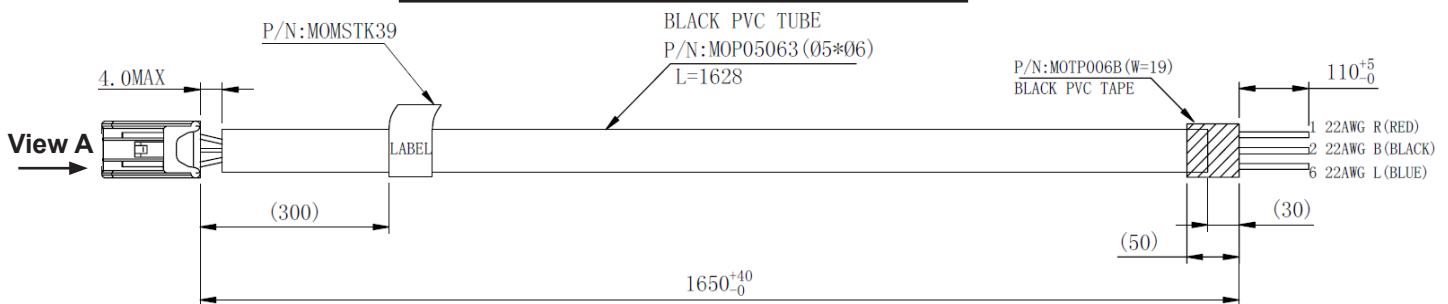
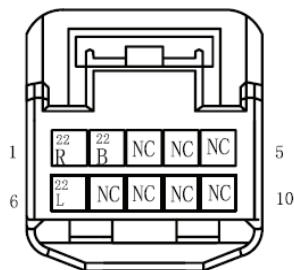
BASIC INSTALLATION TROUBLE-SHOOTING**View A (Terminal Side)**

PIN	FUNCTION	NOTE	COLOR
1	+12VDC SWITCHED	IGNITION	RED
2	GROUND		BLACK
3			
4			
5			
6	+12VDC	BATTERY	BLUE
7			
8			
9			
10			