

GENUINE Padded Cargo Liner

INSTALLATION INSTRUCTIONS



Thank you for purchasing a Genuine Mazda Accessory.

Before removal and installation, please thoroughly read these instructions.

For your safety, please read the contents of this booklet to properly install and use the Padded Cargo Liner.

Keep these instructions with your vehicle records for future reference.



- There are several  **WARNING** and  **CAUTION** sections in this booklet concerning safety when installing or removing the Padded Cargo Liner. Always read and follow the instructions in order to prevent injuries, accidents, and possible damage to the vehicle.

 **WARNING :** Indicates a situation in which serious injury or death could result if the warning is ignored.

 **CAUTION :** Indicates a situation in which bodily injury or damage to the vehicle could result if the caution is ignored.

- For areas indicating the tightening torque in this instruction manual, tighten to the specified torque by using a torque wrench. For areas in which the tightening torque is indicated inside parentheses (), the tightening torque is indicated as a reference value, however tightening using a torque wrench is not necessary.
- Do not modify the Padded Cargo Liner.
- Do not install the Padded Cargo Liner in any way other than described in the following instructions.
- If in doubt, please contact your Mazda dealer to install the accessory in order to prevent errors in installation.
- If you have any questions about the use of the accessory, ask your Mazda dealer for proper advice before using it. Mazda and its suppliers are not responsible for injuries, accidents, and damage to persons and property that arise from the failure of the dealer or installer to follow these instructions.
- To ensure safety and reliability of the work, installation, removal and disposal work must be carried out by an Authorized Mazda Dealership.
- Be careful not to lose removed parts, and be sure that they are kept free of dirt, scratches, or damage.

PART NAME: Padded Cargo Liner
PART NUMBER: KR9EV0360/KRSEV0360
VEHICLE: CX-70





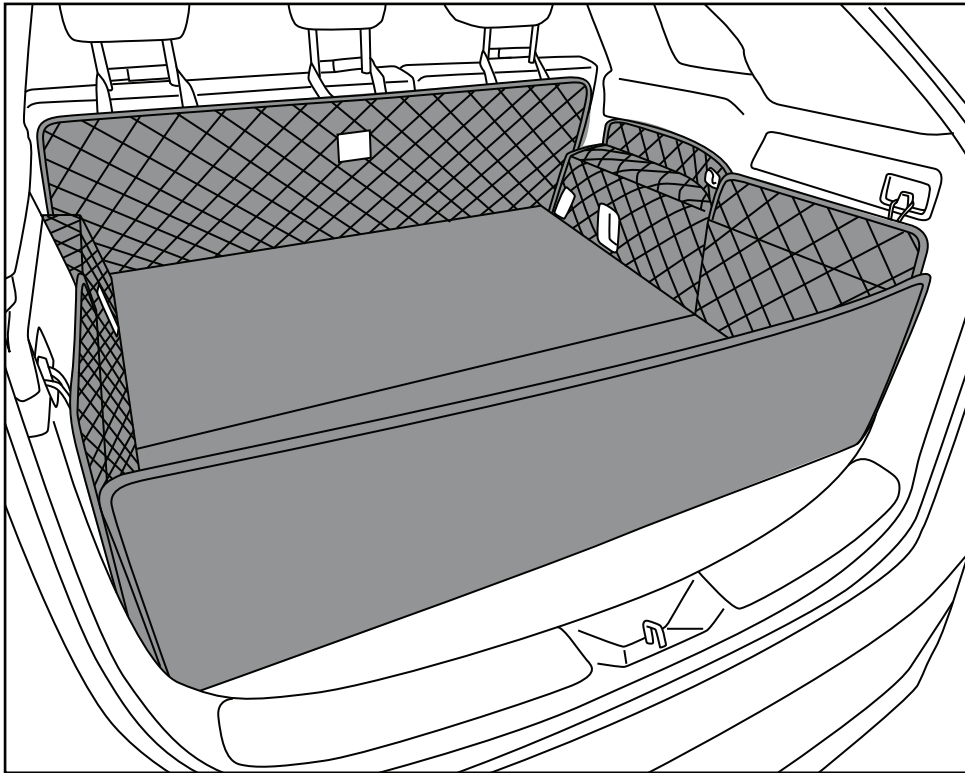

1. PARTS

NOTE

- Verify that the kit includes all the following parts and that the parts are not dirty, scratched, or damaged.

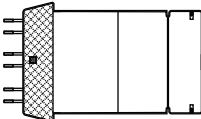

Padded Cargo Liner (KR9EV0360/KRSEV0360)

Part	Part name	Qty	Part	Part name	Qty
	Side Panel Left	1		Main Panel Center	1
	Side Panel Right	1		Installation Inspection Sheet	1
	Installation Instructions	1			

Items needed for installation:

- Isopropyl Alcohol

2. SIDE PANEL INSTALLATION

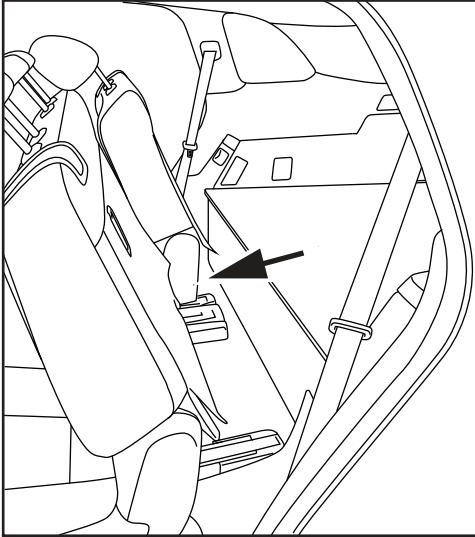

1. Move rear seats forward to allow for access to cargo area from rear door opening.

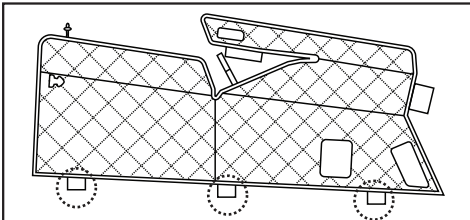

2. Locate the Padded Cargo Liner Left Side Panel.

Note the protective felt on bottom edge hook and loop fastener, do not remove yet.

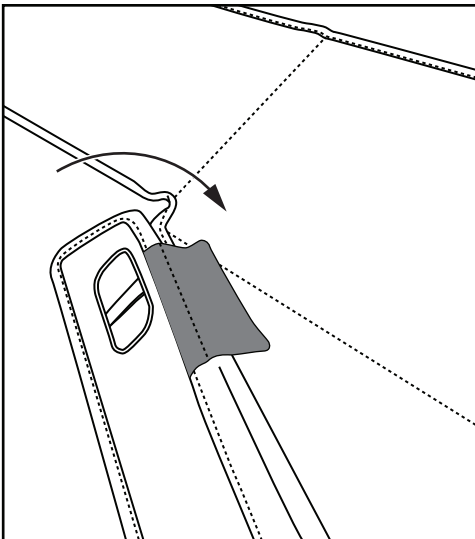

3. Attach hook and loop fastener on back of side panel to form armrest shape.

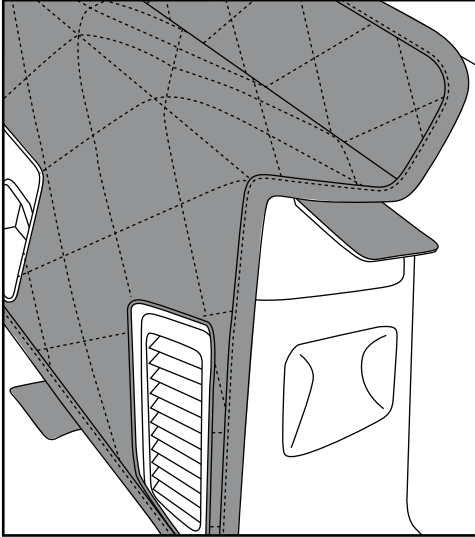

4. Place side panel tightly against vehicles side panel.

Align front edge of Padded Cargo Liner side panel to leading edge of trim as shown.

Locate and align the opening of the Padded Cargo Liner to the cargo hook and vent on the vehicle side trim.

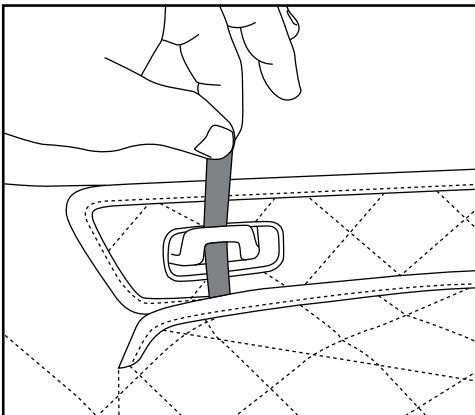
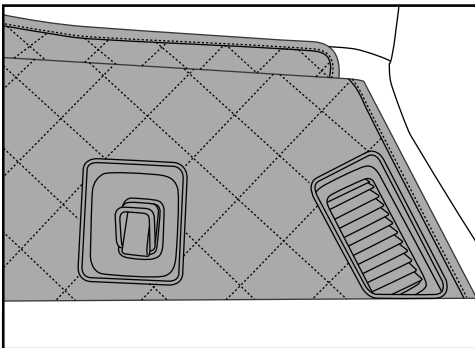

5. Secure the hook and loop fastener strap through the hole and around the cargo hook as shown.

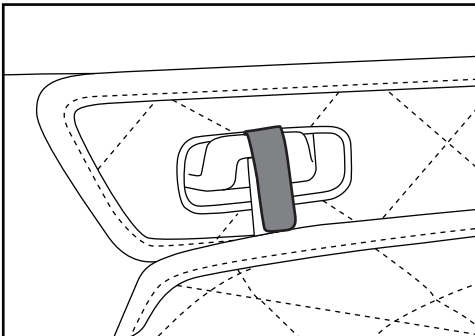

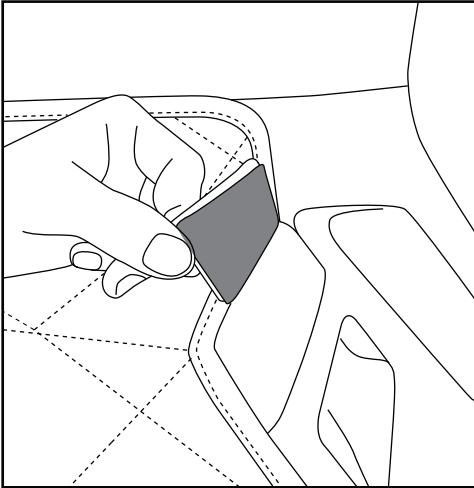

6. Clean front edge of side panel with Isopropyl alcohol. Do not touch surface after cleaning.

Making sure side panel is in position, peel liner from adhesive side of hook and loop fastener located on front edge of side panel.

With a wiping motion, press hook and loop fastener down firmly to the vehicle side panel as shown.

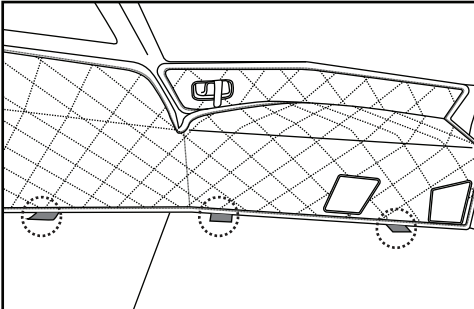
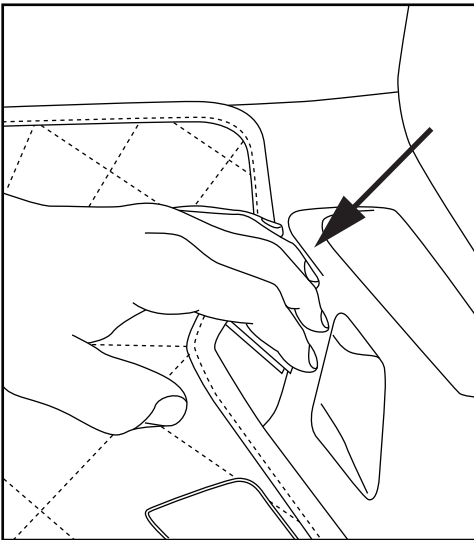

7. Ensure the side panel is leaning against the vehicle trim for proper placements of the hook fasteners locate at the bottom of the side panel.

Peel protective felt from hook fasteners and attach to trunk board as shown.

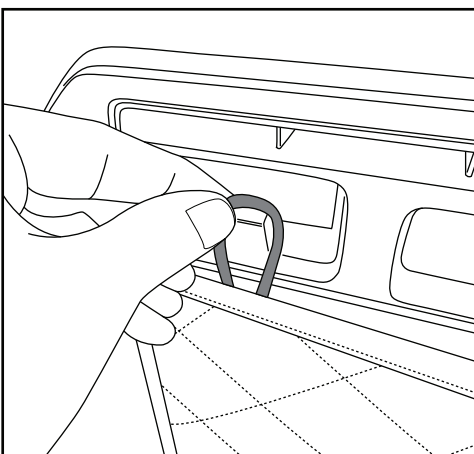

8. Locate Bungee loop at rear of side panel. Pull and loop over rear cargo hook.

Repeat steps 1- 8 for other side

3. FLOOR PANEL INSTALLATION

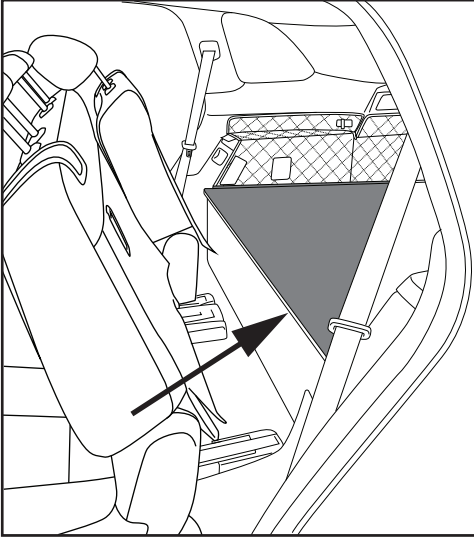

9. Place main panel into rear of vehicle and align edge of main panel to the front edge of the trunk board trim as shown.

Move 2nd row of seats to most rearward position. Position back of seats to in normal sitting position.

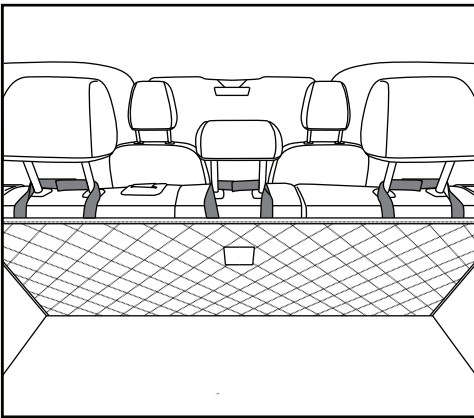

10. Raise the 2nd row headrests, and then attach head rest strap to secure main panel.

Lower the 2nd row headrests after installation.

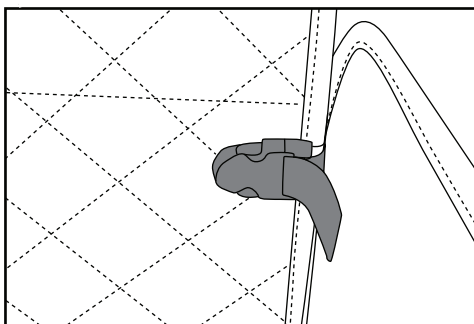

11. Clip rear panel to side panels to complete the installation.

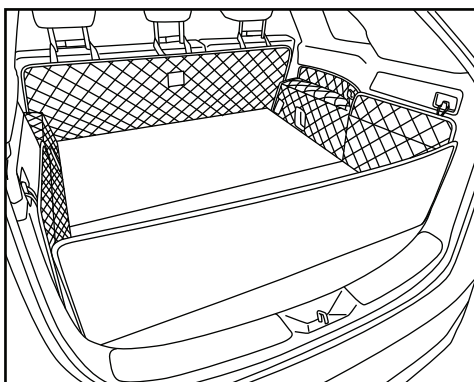

12. Congratulations! You have completed the installation of the Genuine Padded Cargo Liner.

Date:					
VIN.					
Approved		Checked		Person in Charge	

INSTALLATION INSPECTION SHEET	Padded Cargo Liner
	KR9EV0360/KRSEV0360

Perform the following inspections

⚠ IMPORTANT INSPECTION ITEMS

- These inspections and check are important for safety and legal compliance.

⚠ WARNING

- Check that there is no one directly in front of or behind the vehicle and that no one is near the engine compartment before starting the vehicle's engine. Sudden vehicle movements may result in serious injury.
- Do not start the engine in indoor places with poor ventilation such as garages. Exhaust gases may build up and cause poisoning or suffocation.
- Be sure to park the vehicle on a level surface and block the wheels before carrying out any operation checks.

1. Inspection items after installation

- Verify the fitment between the vehicle part and the installed part, and inspect for damage or dirt.

Check

2. Vehicle parts reinstallation

Inspect the installed/reinstalled parts for the following items:

INSPECTION PARTS	INSPECTION ITEMS			
	Clearance and fit	Scratches, dirt, and harness interference	Installation, tightening and engagement	Operation check
No loose threads or other manf. defects	--	•	--	--
Side panels are installed per instructions.	•	•	•	•
Velcro on front of side panel fully adhered	•	--	•	•
Main panel is correctly installed	•	--	•	•

- The term of validity for this sheet: 3 years