

HUNT

THE CHASE IS ON • HUNTBIKEWHEELS.COM

Wheels User Guide

We hope you are delighted with your new Hunt Bike wheels and we'd like you to have as much fun riding them as we do. There are of course some inherent risks associated with using any bicycle wheels and this guide is provided so you are fully aware of how to use your wheels correctly. It contains important information you need to know so that you can continue to enjoy your wheels safely for many years. Please do read through it carefully, even if you are an experienced cyclist. We have tried to make this guide as clear and simple as possible but if there is anything you are still unclear about we encourage you to please ask us. You can contact us by phone or e-mail using the contact details on our website at www.huntbikewheels.com

Thanks, and enjoy your riding.

The Hunt Bike Wheels Team

BEFORE USING YOUR WHEELS PLEASE READ THESE INSTRUCTIONS CAREFULLY ALONG WITH ANY ADDITIONAL USER GUIDES PROVIDED WITH YOUR WHEELSET. DETAILED USER GUIDES FOR HUNT BIKE WHEELS ACCESSORIES CAN BE FOUND AT WWW.HUNTBIKEWHEELS.COM PLEASE SAVE THESE INSTRUCTIONS AND PASS THEM ON TO ANYONE ELSE WHO MAY USE THE PRODUCT OR PURCHASE THE PRODUCT FROM YOU.

General Safety Warnings

- There are inherent risks associated with cycling. This includes the risk of serious or fatal injury.
- Always follow the instructions in this guide along with any other advice or guides provided to you by Hunt Bike Wheels. Failure to follow these instructions may result in serious or fatal injury.
- If after reading this guide or at any other time you have any concern or doubt about the use, maintenance, repair or fitting of your Hunt Bike Wheels then please contact us or refer to a qualified cycle mechanic. Our contact details can be found at; www.huntbikewheels.com

Intended use; rider & equipment weight limits.

- Only use the wheelset for uses stated in the product description at www.huntbikewheels.com
- Do not use off road unless this purpose is stated in the product description
- Do not use for mountain biking unless this purpose is stated in the product description
- Do not use on tandems or trikes.
- Follow the rider & equipment weight limits in the product description
- Do not use disc brake wheelsets with rim brakes.
- Do not use rim brake wheelsets with disc brakes.

Quick releases and Through-axles

PLEASE READ THIS SECTION CAREFULLY - FAILURE TO ENSURE THAT QUICK RELEASES ARE TIGHTENED CORRECTLY AND SUFFICIENTLY MAY RESULT IN SERIOUS OR FATAL INJURY.

- Only use your wheels with the correct Hunt Bike Wheels Quick releases. If you are unsure which quick releases you require please contact us.
- If you are using your wheels with through axles, only use the through axles supplied by your frame or fork manufacturer. Only use Hunt Bike Wheels adapters. User guides for adapters can be found at www.huntbikewheels.com
- Before every ride ensure that the quick release is tightly closed. The quick release should not be easy to undo, and when in the closed position the 'Hunt' name should show on the outside of the quick release. Make sure that the wheels are securely attached to the bike by pulling sharply on each wheel. The wheels should not move in the frame or fork.
- If using through axles check the instructions provided by your frame or fork manufacturer.
- Check that your frame and fork are compatible with quick releases before using.

Fitting and adjusting quick releases

- Only operate quick releases by hand, never use a tool as this may damage the mechanism making it unsafe.
- Open the quick release fully before fitting the wheels.
- Before closing the quick release ensure the hub is fully engaged in the centre of the fork or frame.
- If the clamping force is not enough, then open the lever and adjust the nut on the opposite side by turning the nut clockwise. Then re-close the lever.
- If the clamping force is too high to close the lever, then open the lever and adjust the nut on the opposite side by turning the nut slightly anti-clockwise. Then re-close the lever.
- Only adjust the quick release tension with the adjusting nut on the opposite side to the lever.
- Ensure that you re-close/attach brake cables if required.
- Check that the end of the quick release skewer is not recessed by more than 2mm inside the outer side of the adjusting nut.
- Do not attempt to turn the adjusting nut with the lever in the closed position.
- Ensure the lever is not touching any part of the bicycle when closed.
- Ensure the wheels are centred in the frame / fork before you tighten the quick release.

Installing your hunt bike wheels & 3rd Party Components.

- For instructions on how to install your Hunt Bike Wheels and fit any 3rd Party Components see the instructions provided by your bike or 3rd party component manufacturer.
- Check that any 3rd party components are compatible with your Hunt Bike Wheels before attempting installation.

Fitting tyres, Tyre Widths and Tyre Pressures

PLEASE READ THIS SECTION CAREFULLY - FAILURE TO FOLLOW THE ADVICE BELOW AND OUR GUIDANCE ON WWW.HUNTBIKEWHEELS.COM OR ELSEWHERE MAY RESULT IN FAILURE OF YOUR TYRES WHICH CAN CAUSE SERIOUS OR FATAL INJURY

- Please follow the tyre pressure information for your wheels at www.huntbikewheels.com in the USER MANUAL section.
- Please follow suitable tyre size information on the wheelset product page for your wheel model name at www.huntbikewheels.com, if unsure please contact us for accurate tyre size information for your wheels.
- Only use tyres compatible with the ETRTO rim diameter for your wheels. This may be printed on the side of your rims and is also available on the website product page for each current wheel model, if you have a discontinued wheelset or are at all unsure please contact us for the ETRTO for your wheels.
- Follow any advice on tyre suitability on www.huntbikewheels.com or other advice we may provide to you.
- Ensure that the tyre fits securely to the rim when fitting and cannot easily fit over the rim lip. DO NOT USE if the tyre can be removed without tyre levers.
- DO NOT USE tyres that have previously been fitted to another wheelset. These may have been stretched in use causing an insecure fit on your Hunt Wheels.
- H-Lock Wedge rims - (used on some models of 55Carbon Wide Aero, 30 & 50 Carbon AeroDisc and 30 Carbon Gravel Disc rims) should only be used with specifically designated as **TUBELESS** or **TUBELESS READY** and constructed with **CARBON BEADS**. These tyres have predictable bead diameters and a strong bead construction. You can use inner tubes with these Hunt HLW rims as long as they are used in tubeless tyres. Tyres constructed with Aramid/Kevlar beads including, Hutchinson Fusion 5 tyres and Mavic tyres are not suitable for use with HLW rims. If in doubt please contact your tyre manufacturer.
- Never exceed the maximum pressure stated for your tyre or your wheelset.
- Use only plastic tyre levers.

Inspecting and looking after your Hunt Bike Wheels

Wear and tear of components in your hunt bike wheels will occur as a result of normal use. If not attended to then these components may fail in use with a risk of serious or fatal injury. You should check the following regularly, and at least once per month or every 500 miles (whichever is sooner). If using your bike in wet weather or off-road, then check your wheels at least every week or every 100 miles (whichever is sooner):

Important warnings

- Every bicycle component has a finite useful life. Bicycle wheels are subject to wear and stress in use. Different materials and components wear or fatigue from stress at different rates with different life cycles which will vary extensively depending on the conditions in which they are used and the loads they are exposed to. If a component's life cycle is exceeded, the component can suddenly and catastrophically fail without warning, causing serious injury or death to the rider. You must frequently inspect components for any signs of wear or fatigue. If you have any queries, always consult a qualified cycle mechanic or contact us using the details at www.huntbikewheels.com. Scratches, cracks, bending, fraying or discolouration are all signs of stress-caused fatigue and may indicate that a component is at the end of its useful life and needs to be replaced. When you see any of these signs, please stop using your wheels and take them to a qualified cycle mechanic for inspection, repair or replacement as necessary. Products may also be returned to Hunt Bike Wheels for inspection*

- Road salt can accelerate corrosion of metal parts. It is important that any road salt residue is cleaned off as soon as possible.
- While the materials and workmanship of your wheels may be covered by a warranty for a specified duration, this is not a guarantee that the product will last the term of the warranty without failure. The warranty is not meant to suggest that the bicycle or component cannot be broken or will last forever. It only means that the product is covered subject to the terms of the warranty.
- For aluminium rim brake wheelsets check that the wear dot indicators on your rims are still visible. If this wear dot disappears then the brake track has become worn out and you should discontinue using the wheels immediately. (Top tip - when you notice that the wear dot is becoming smaller you can use the wheels on an indoor trainer where braking is not required as frequently but do not use once the wear dot has fully disappeared).
- Check that bearings are running smoothly without excessive resistance. A small amount of roughness is fine but if there is significant resistance this is an indication of excessive wear and the bearings should be replaced. Only replace bearings with spares provided by Hunt Bike Wheels and replacement should only be carried out by a qualified cycle mechanic. Wheels can also be returned to Hunt Bike Wheels for bearing replacement.*
- Check that spokes and nipples have not come loose.
- Check for any signs of damage to any of the wheel components in particular at the rim bed where the spokes are attached and on the spoke nipples.
- Check for trueness and roundness. If your wheel appears to be out of true, then please refer to a qualified cycle mechanic. Wheels can also be returned to Hunt Bike Wheels to be re-trued. *
- Check the freehub mechanism is engaging correctly, and clean and lubricate if necessary www.huntbike-wheels.com for instructions.
- Check for wear on your brake pads. If your wheel is provided with brake pads check the user guides for these at www.huntbikewheels.com
- For carbon rim brake wheelsets check the braking track for wear or loose fibres. If the braking track is worn or loose fibres are showing discontinue use immediately.

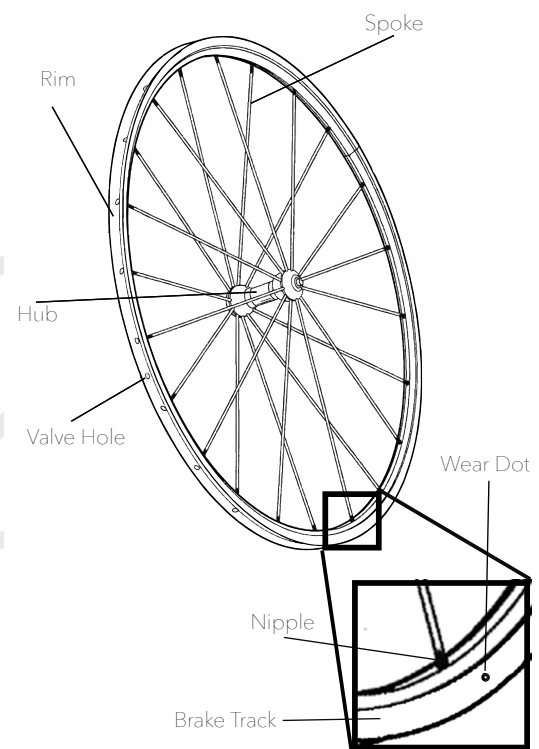

Replacing Spokes

Broken spokes are reasonably rare but can happen from time to time as a part of normal wear and tear. All hunt bike wheels are provided with replacement spokes & nipples to allow a qualified cycle mechanic to replace a broken spoke easily.

In addition

- Never clean your wheels using a pressure washer, this will damage bearings and reduce service life significantly. Wash using only water and soap or a specialist bike cleaner.
- Do not use solvents, detergents, paints, or abrasives as these may damage the wheels. This damage may not be visible.
- Do not leave exposed to high temperatures, for example in a hot car.
- Do **NOT** apply any lubricant, grease, or oil to the brake pads or braking surfaces. If any of these substances do come into contact with the brake pads or braking surface clean thoroughly with soap and water.
- Some braking noise may occur with new wheels or brake pads; this is normal particularly with carbon braking surfaces. This noise should stop when the pads have been run in (approx. 500 miles)
- You should also check your wheels carefully for damage after any accident or major impact such as running through a pot-hole
- If you are in any doubt about maintenance, inspection, repair or any other aspect of owning your Hunt Wheels then you should contact a qualified cycle mechanic or get in touch with us using the details at www.huntbikewheels.com

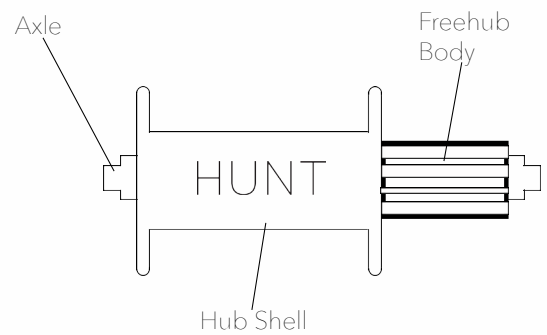

Brake pads and brake setup

- Follow instructions provided by your bicycle or component manufacturer when fitting brake pads and setting up brakes.
- Braking distances will be increased in wet weather, particularly with carbon braking surfaces. Reduce speed and brake earlier in wet weather.
- Check brake pad surfaces regularly for contamination by dirt, grease, oil or particles that may impair braking performance or damage braking surfaces.
- Check the brake pad wear indicator regularly and replace brake pads when required.
- Brake pads are supplied with all carbon rim brake wheels. Do not use any other brake pads with carbon rim brake wheels. Check the user guides at www.huntbikewheels.com. Replacements can also be ordered through www.huntbikewheels.com
- Never use a brake pad on a carbon rim if it has previously been used on an aluminium rim. The pads will have been contaminated by aluminium particles which will damage the carbon braking surface.

Braking Safely

- Extended periods of braking may cause excessive heat to build up in your wheels. This can impair braking performance. With rim brake wheelsets this heat may also cause damage to your wheels or cause dramatically increased tyre pressure resulting in the failure of tyres and/or tubes with a risk of serious or fatal injury.
- Temperature build up will be most severe in the circumstances below:
 - Long and/or steep descents
 - Riding on hot days
 - Higher rider & equipment weights
- Stop regularly on long descents & allow your braking surface to cool before continuing. This is particularly important if you are braking continuously.
- If you suspect your brakes have heated up significantly you **MUST** stop immediately and allow them to cool.
- Before commencing a long descent reduce your tyre pressure by 10psi vs your normal setting. This will reduce the risk of tyre failure as a result of excessive heat build-up.

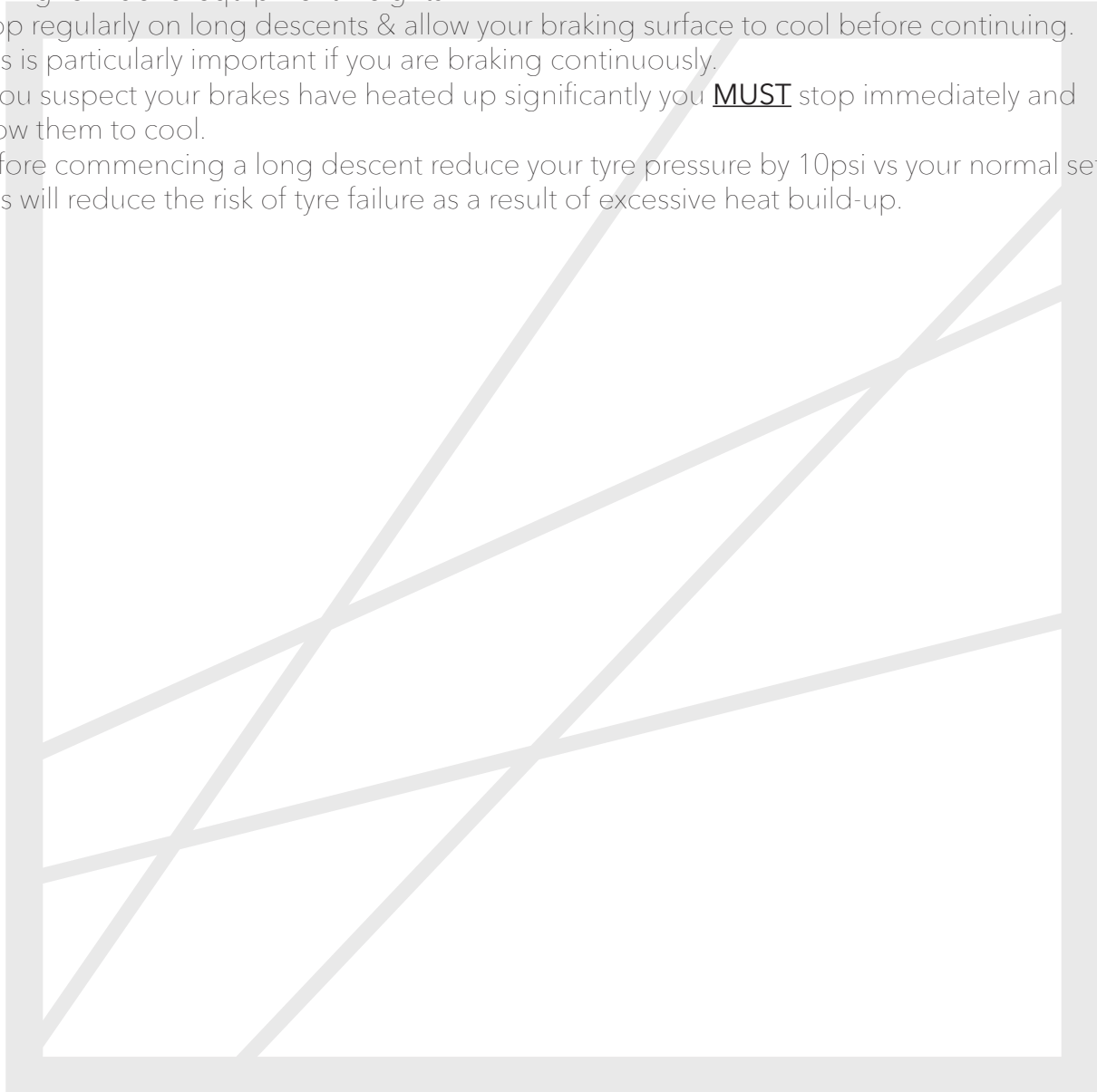

*Charges may apply for maintenance work but we will always confirm these with you before any work is carried out.

Hunt Bike Wheels and The Rider Firm are trading names of ITS Cycling limited, 8 Huffwood, Partridge Green, RH13 8AU, UK. A company registered in England and Wales no. 8583700