

Hinge Assembly

To assemble the hinge(s) to the door and cabinet, please follow the below steps carefully:

Step 1:

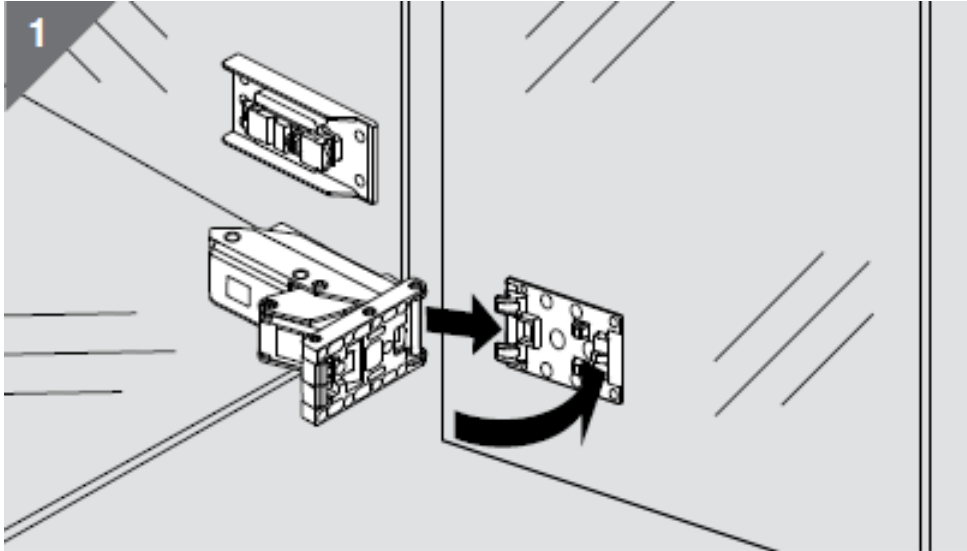

Ensure all hinges are in the closed position creating an "L" shape. Then attach the hinge to the door as shown above.

Step 2:

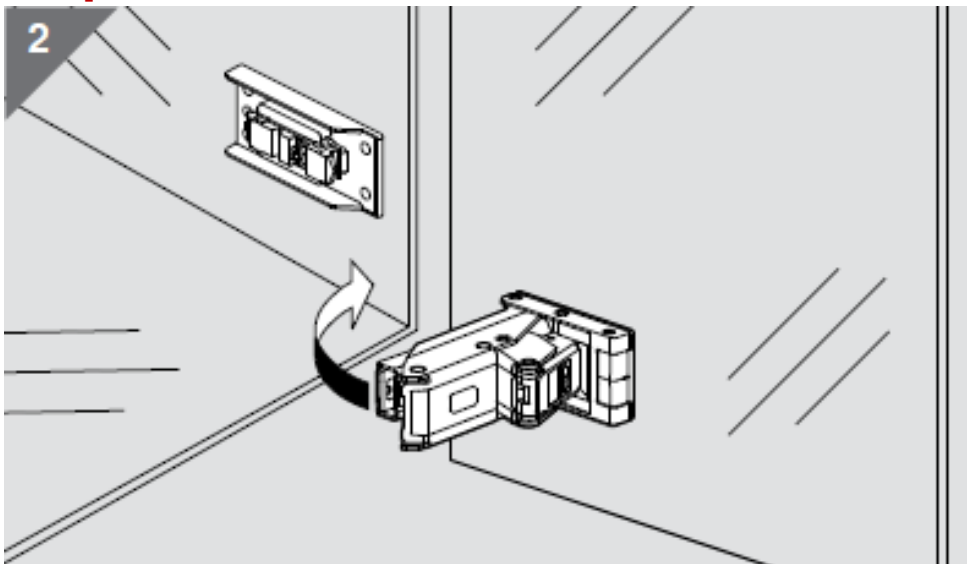

Once all hinges are attached to the door, you will push all hinges to their open position.

Step 3:

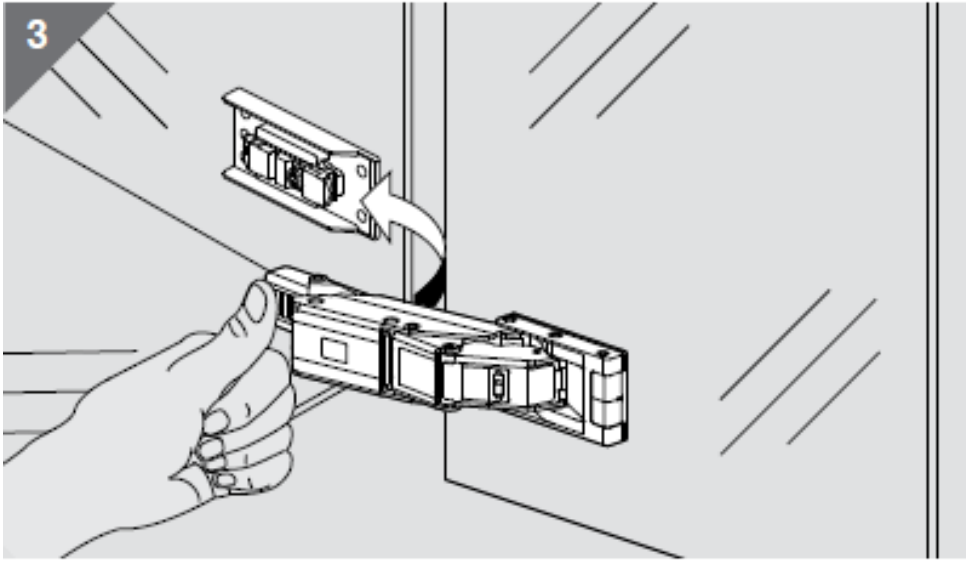

With the hinges all in their open position, pick up the door and attach all hinges to the base plate in the cabinet frame as shown above in the picture above. If done properly, you will hear a “click” sound. Ensure this is done for all hinges in the cabinet.

Hinge Adjustment

Adjusting the hinges is important to ensure the door is centered on the cabinet. It is important to note that these adjustments are to be made in small increments of ¼ turn, and to apply the same adjustments to each hinge **before** making another turn on one hinge. Failure to do so may cause tension in the hinge which could result in the cabinet and/or door to warp and be further damaged if enough tension is applied. Please follow the below instructions carefully:

Vertical Adjustment:

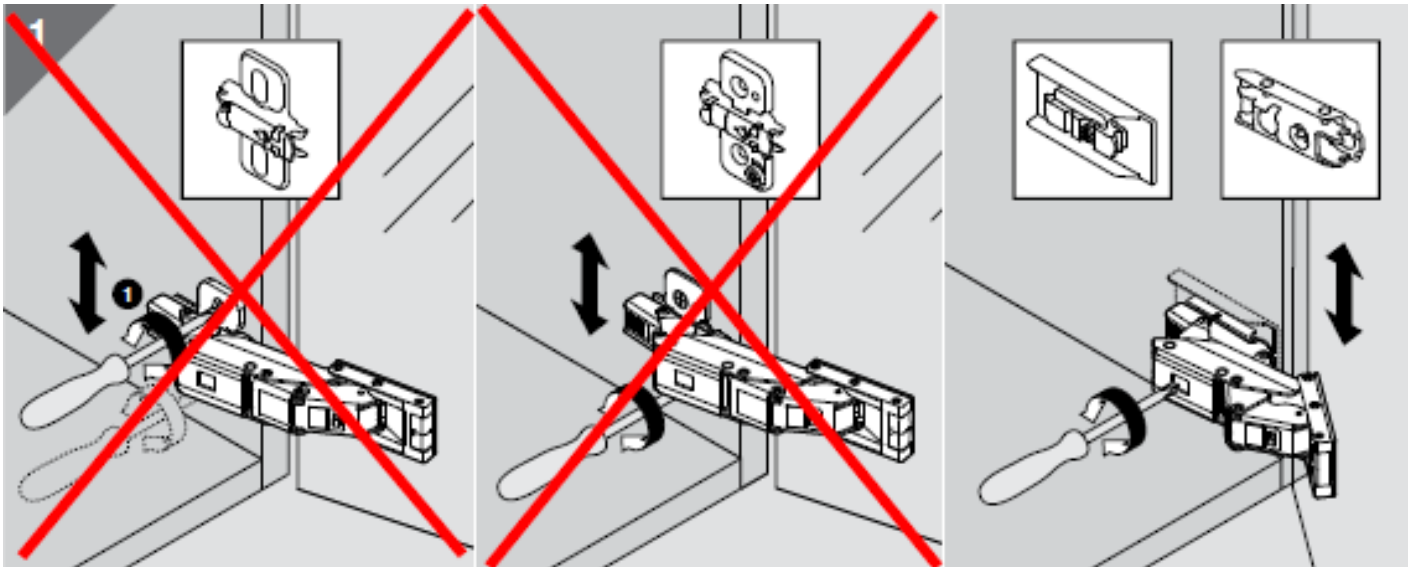

Use the center screw to adjust the vertical alignment of the door. To gain access, open the door to approximately a 45° angle or until you can see the center screw through the square opening in the hinge as shown above.

Depth Adjustment:

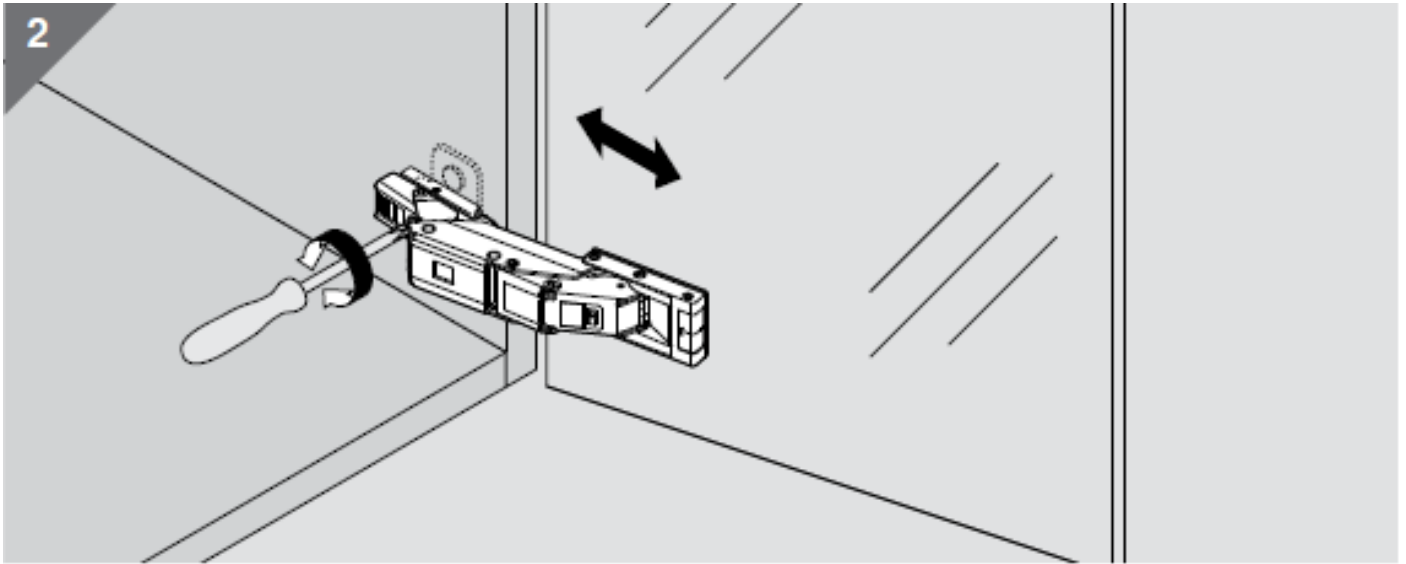

Use the screw at the back of the hinge (closest to the back of the cabinet) to adjust the depth alignment of the door. You can access it by having the door open at 90° angle as pictured above.

Horizontal Adjustment:

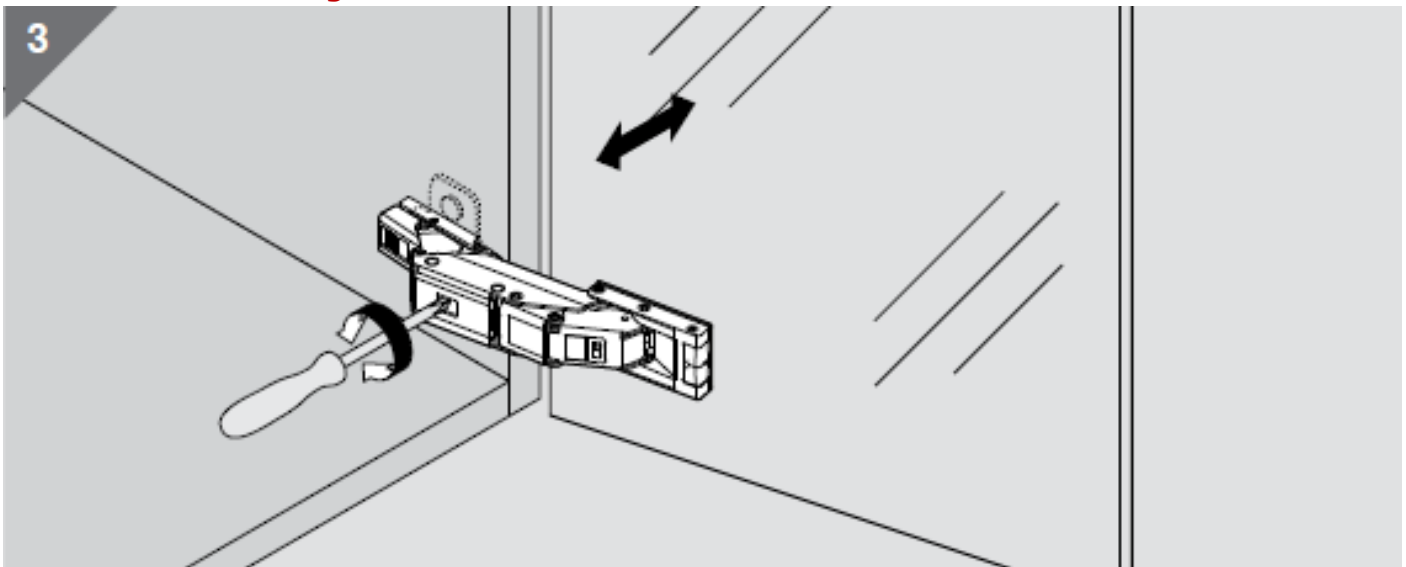

Use the screw at the front of the hinge (closest to the mirror door) to adjust the horizontal alignment of the door. You can access it by having the door open at a 90° angle and placing the driver through the square hole in the hinge as pictured above.

Hinge Removal

To remove the hinge(s), you will need to have the door in its open position. It's important to note that you ensure to have a good grip on the door as you will be supporting it once the hinges are released. Please follow the below steps carefully to ensure safe removal of the door and hinges.

Step 1:

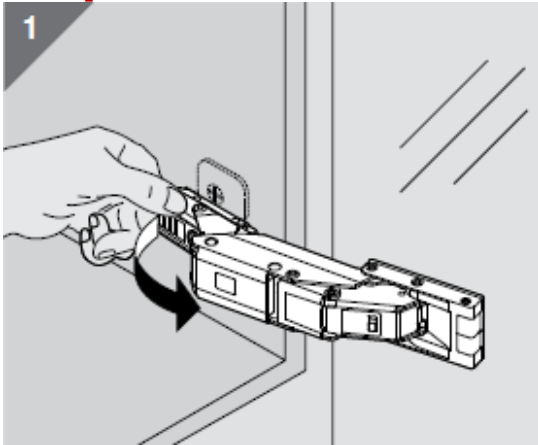

Place your hand at the back of the narrow part of the hinge. Here you will find a small tab in which you will pull inward (towards the inside of the cabinet). This will release the hinge from the cabinet (hinge plate). Do this step for all hinges before proceeding.

Step 2:

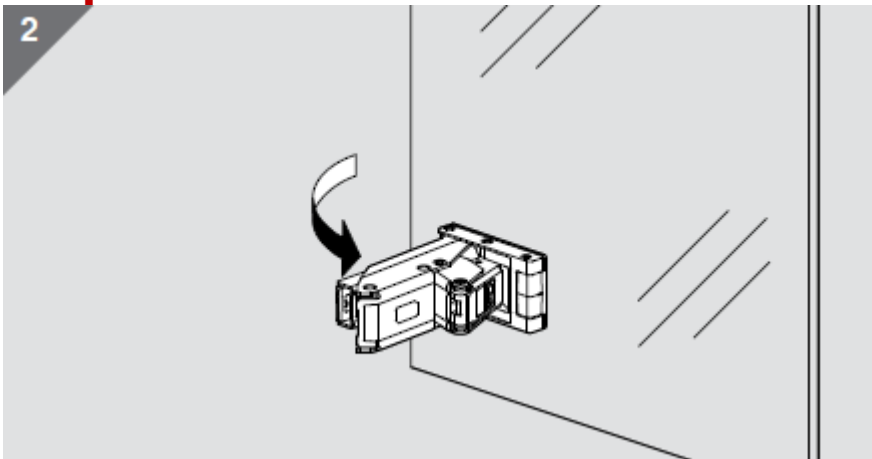

Once all hinges are released, they will remain attached to the mirror door. Carefully place the mirror door on a clean, flat surface. Then "close" the hinges as shown above and proceed to step 3.

Step 3:

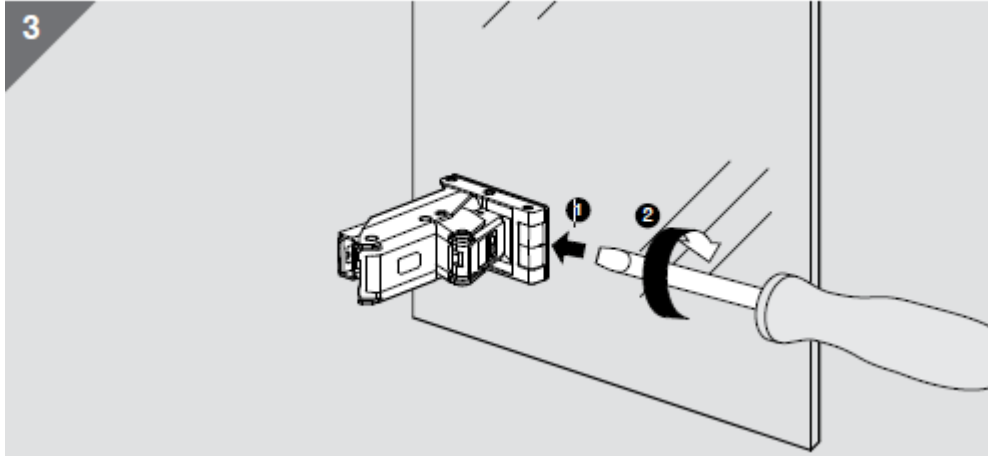

Using a flat head screw driver in one hand and holding the hinge with your other, carefully insert the flat head between the hinge and the plate attached to the mirror door. Then turn your driver to lift the clip that attaches the hinge to the hinge plate on the mirror door until it releases. Please be sure you're holding the hinge so it does not fall onto the door and cause damage.