

INSTRUCTIONS FOR MODELS

CPT-1401

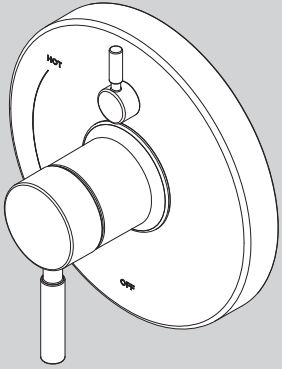

TOOLS AND SUPPLIES

Phillips
Screwdriver

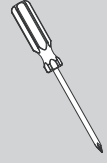

Measuring
Tape

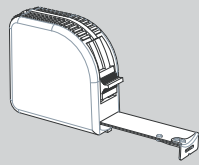

IMPORTANT



- Do not over-tighten any connections or damage may occur.
- Be sure to read instructions thoroughly before beginning installation.
- Be sure to have properly adjusted the Temperature Limiting Stop (TLS) as per the Valve Installation Instructions before installing Valve Trim.

SAFETY TIPS

Cover your drain to prevent loss of parts.

MAINTENANCE

Your new Speakman Product is designed for years of trouble-free performance. Keep it looking new by cleaning it periodically with a soft cloth. The use of harsh chemicals and abrasives on any of the Speakman custom finish products may damage the finish and void the product warranty. Please be sure to only use approved cleaners. Please contact Speakman for any clarification of acceptable cleaners.

WARRANTY

Warranty information can be found at:
www.speakman.com

- 1** Clean wall surface. Place Mounting Base (1) onto the valve, align mounting holes, and secure with supplied screws (2).

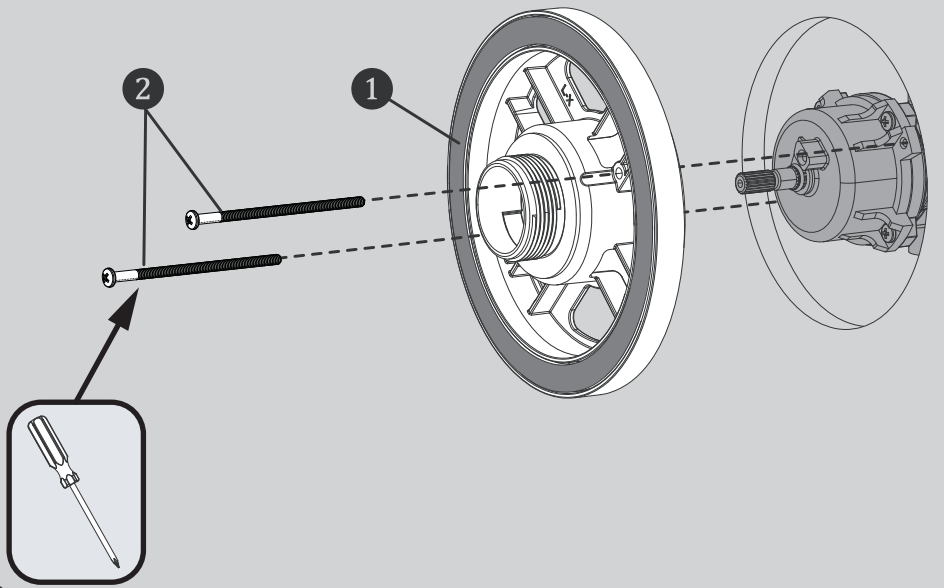

- 2** Verify the position of the Spindle within the Mounting Plate, as shown below. If the end of the Spindle extends beyond the Mounting Plate, then use the Shallow Mount Adapter. If the end of the Spindle is flush to, or is within the Mounting Plate, then use the Deep Mount Adapter.

FOR SHALLOW MOUNT APPLICATION

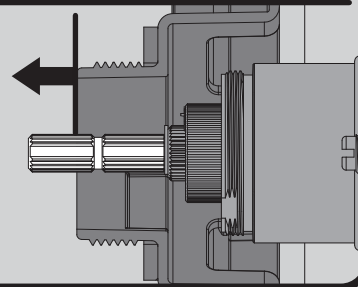
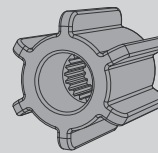

FOR DEEP MOUNT APPLICATION

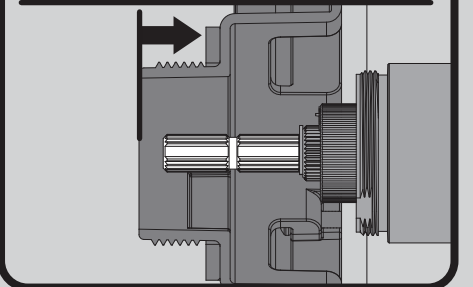
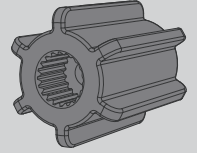

- 3** Confirm that Valve is in the "Off" position. Place appropriate Connector (1) on to the Spindle of the Valve, making sure to orient the Connector so that one set of Splines are in a perfectly vertical position. Secure Connector with 8-32 screw provided (2).

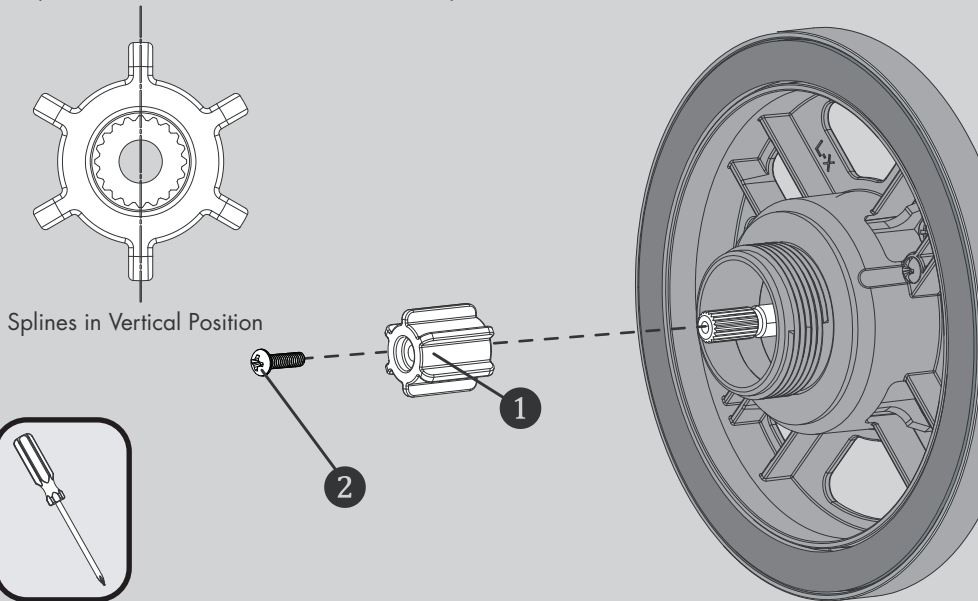

- 4** Place Wall Plate (1) on Mounting Base. Take care to orient the Wall Plate as shown below. Verify the Diverter Valve Stem is in the OFF (vertical) position. Align the Diverter Drive Tube (2) on the Wall Plate to the Stem (3) of the Diverter Valve.

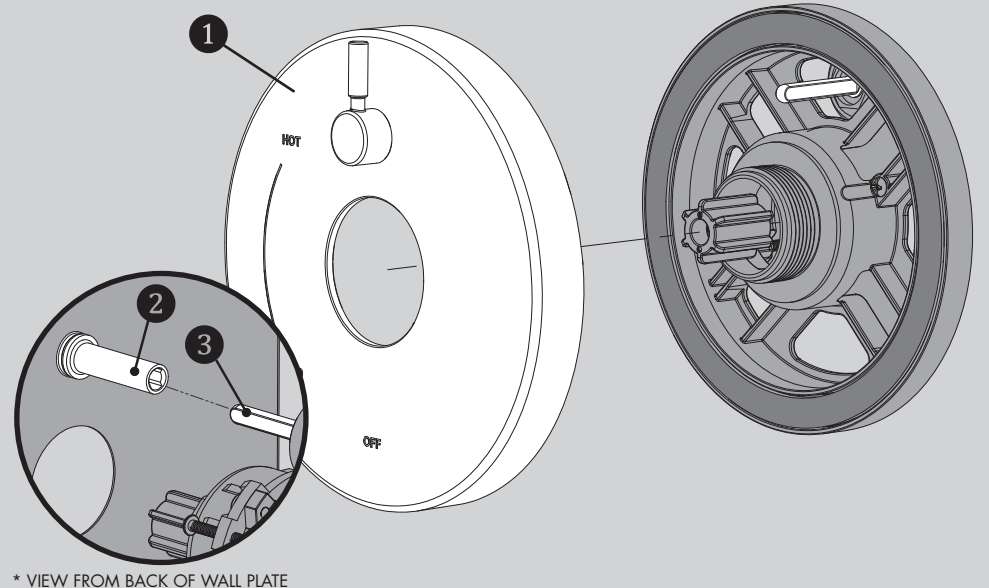

* VIEW FROM BACK OF WALL PLATE

- 5** Align Handle Assembly with Connector (1) and Escutcheon as shown below. Keep Handle (2A) in a stationary vertical position and place over Connector (1) and engage the Splines of the Connector with the Handle Assembly. Keep Handle in the vertical position as you thread Handle Hub (2B) on to Mounting Base. Tighten until snug.

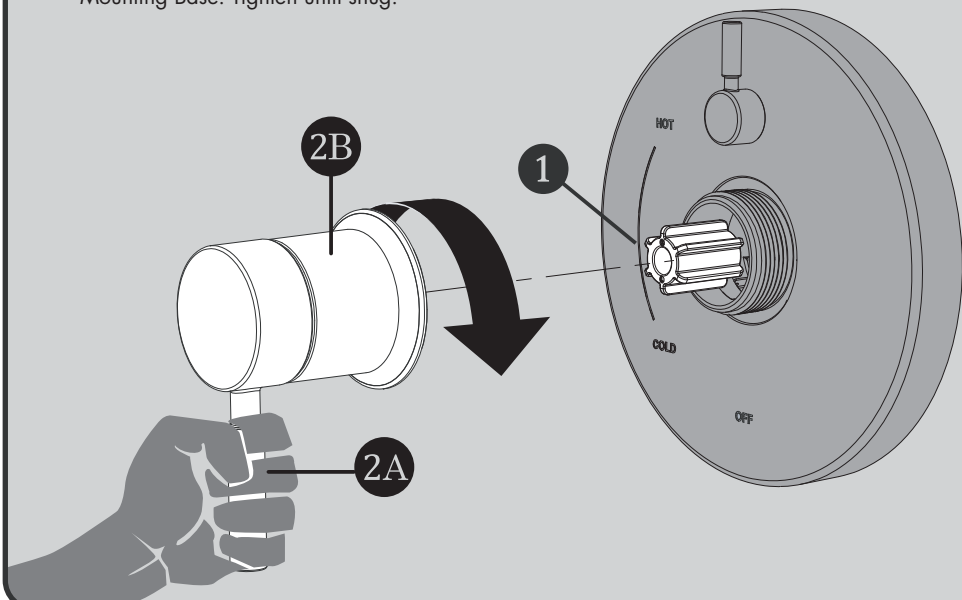

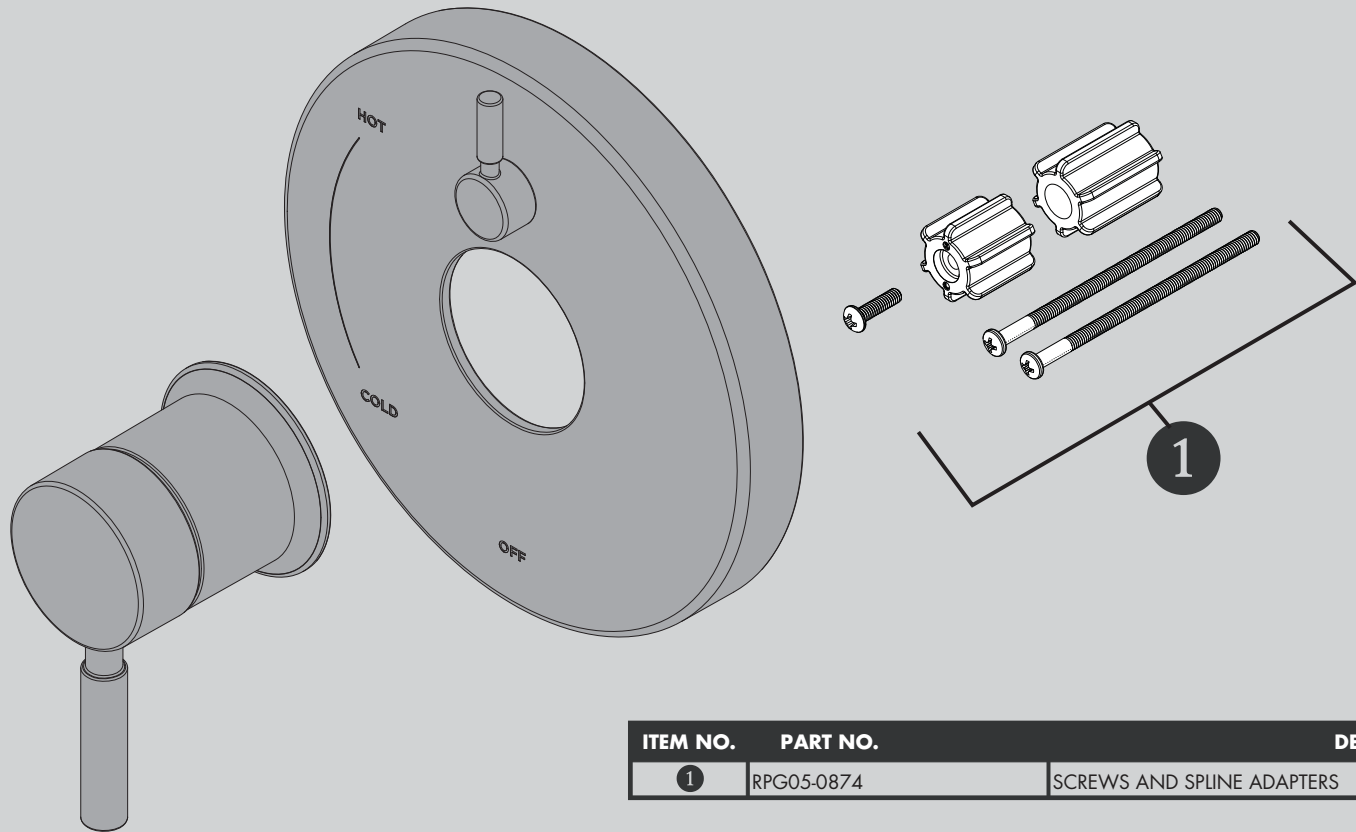

ITEM NO.	PART NO.	DESCRIPTION
1	RPG05-0874	SCREWS AND SPLINE ADAPTERS

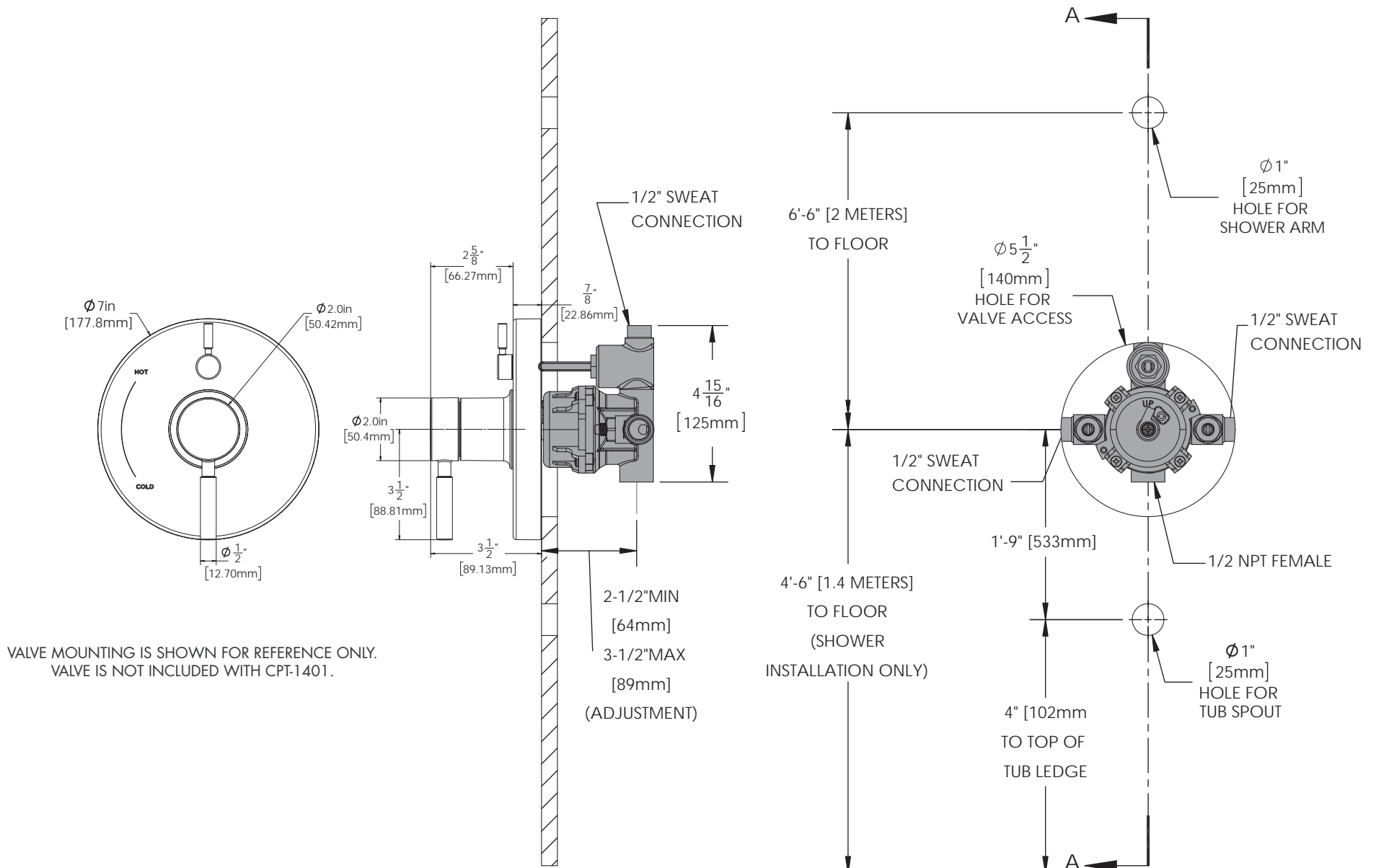

NOTE: TRIM FITS DIFFERENT VALVES. ROUGH-IN DIMENSIONS PROVIDED FOR REFERENCE ONLY.

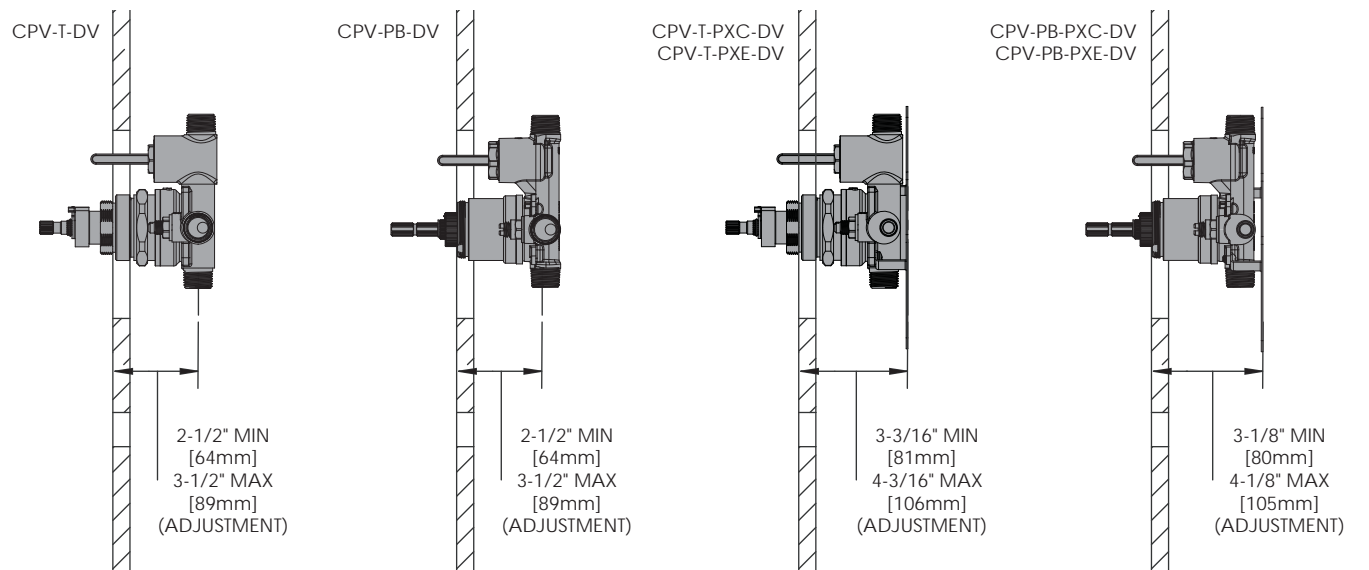

DIMENSIONS SUBJECT TO CHANGE WITHOUT NOTICE.