

Hydro Massage + Air Massage (Dual)

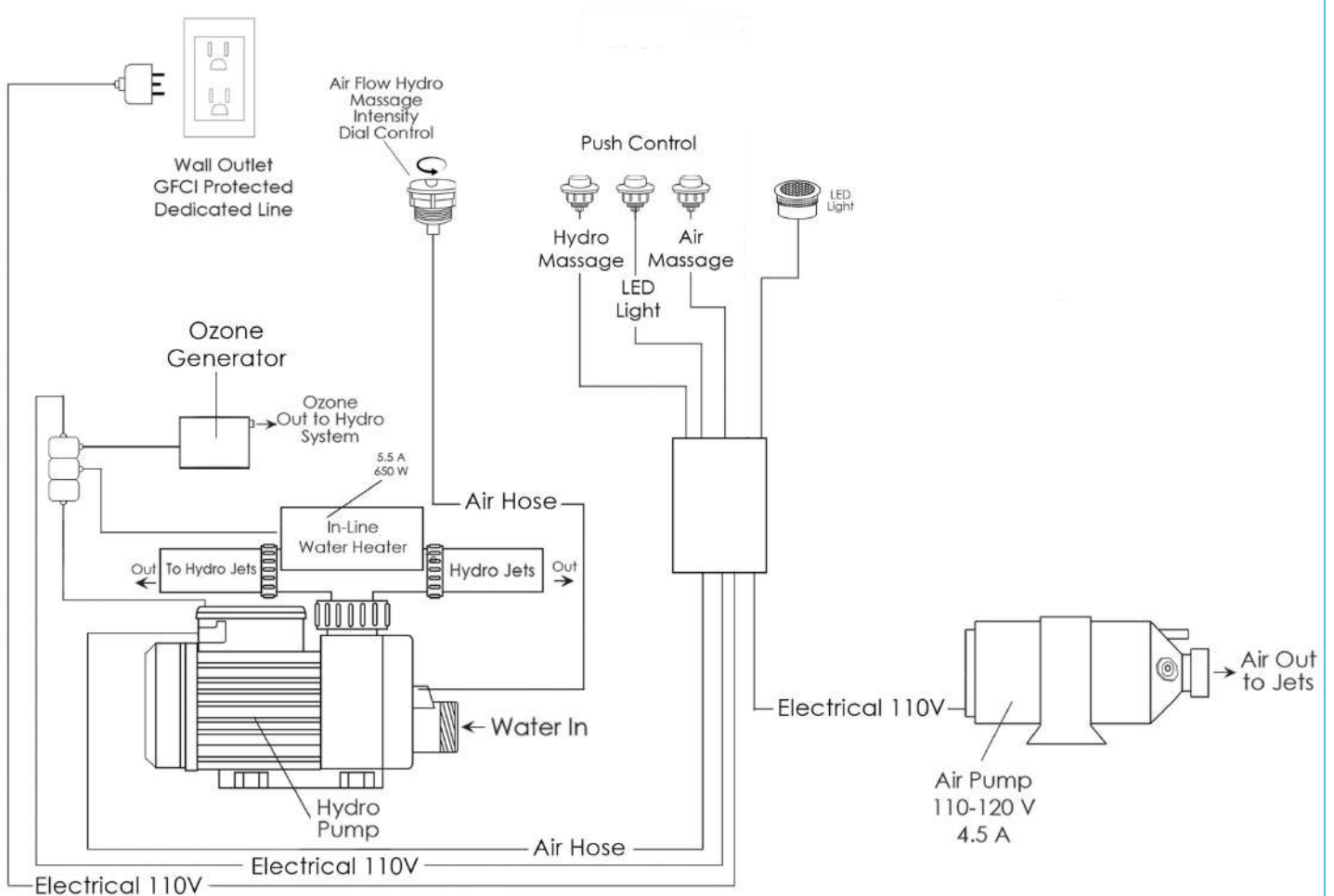

Package Jetting Information:

1. Hydro Massage System 7AMP 1000W
Refer to technical drawing for jet count
Hydro Massage Air Flow Intensity Control
In-line water heater 5.5AMP 1000W
Ozone Sterilization

2. Air Massage System 4.5AMP 500W
Refer to technical drawing for jet count
3 Speed Pump
Autopurge (Activates 20 minutes after pump shutdown)

Electrical Requirements:

One (1) dedicated 120V electrical line with a 20AMP GFCI standard three prong outlet is required