



Installation and Operation Instructions Vented Gas Log and Burner Set



Battery Electronic Models	
DUALBURNER24NE	DUALBURNER24PE
DUALBURNER30NE	DUALBURNER30PE
DUALBURNER36NE	DUALBURNER36PE



NATIONAL FIREPLACE INSTITUTE
We recommend that our gas hearth products be installed and serviced by professionals who are certified in the U.S. by the National Fireplace Institute® (NFI) as NFI Gas Specialists.
CERTIFIED
www.nficertified.org

For use with log sets		
ASHTONWHITEBIRCH24	OZARKCHARREDOAK24	SMOKYWEATHEREDOAK24
ASHTONWHITEBIRCH24	OZARKCHARREDOAK30	SMOKYWEATHEREDOAK30
ASHTONWHITEBIRCH36	OZARKCHARREDOAK36	SMOKYWEATHEREDOAK36

INSTALLER: Leave this manual with the appliance.
CONSUMER: Retain this manual for future reference.

⚠ WARNING: This appliance is for installation only in a solid-fuel burning masonry or UL127 factory-built fireplace, constructed of noncombustible material, and connected to a working flue. (See page 6 for minimum flue opening.)

⚠ WARNING: If the information in this manual is not followed exactly, a fire or explosion may result causing property damage, personal injury or loss of life.

- Do not store or use gasoline or other flammable vapors and liquids in the vicinity of this or any other appliance.
- **WHAT TO DO IF YOU SMELL GAS**
 - Do not try to light any appliance.
 - Do not touch any electrical switch; do not use any phone in your building.
 - Immediately call your gas supplier from a neighbor's phone. Follow the gas supplier's instructions.
 - If you cannot reach your gas supplier, call the fire department.
- Installation and service must be performed by a qualified installer, service agency or the gas supplier.

This appliance may be installed in an aftermarket permanently located, manufactured (mobile) home, where not prohibited by local codes. This appliance is only for use with the type of gas indicated on the rating plate. This appliance is not convertible for use with other gases.

* Aftermarket: Completion of sale, not for purpose of resale, from the manufacturer

Thank you for your purchase. We appreciate your business!

Please carefully read and follow all instructions in this manual. **Pay special attention to all warnings and safety information.**

Following these safety, care, and operation instructions will help ensure many years of dependable and enjoyable service from your fireplace.

Please read and understand these instructions before installing or operating.

TABLE OF CONTENTS

Safety.....	2
Local Codes	3
Product Identification.....	4
Unpacking.....	4
Product Features.....	4
Installation	4
Operation	11
Inspecting Burners.....	12
Cleaning and Maintenance	12
Specifications.....	12
Wiring Diagram.....	13
Transmitter.....	14
Troubleshooting	15
Replacement Parts.....	17
Service Hints.....	17
Technical Service	17
Parts	18
Warranty	20

SAFETY

⚠ WARNING: This appliance is for installation only in a solid-fuel-burning masonry or UL127 factory-built fireplace.

⚠ WARNING: This product can expose you to chemicals including Carbon Black, which is known to the State of California to cause cancer, and Carbon Monoxide, which is known to the State of California to cause birth defects or other reproductive harm. For more information go to www.P65Warnings.ca.gov.

IMPORTANT: Read this owner's manual carefully and completely before trying to assemble, operate or service this appliance. Improper use of this fireplace can cause serious injury or death from burns, fire, explosion, electrical shock and carbon monoxide poisoning.

⚠ WARNING: Any change to this appliance or its controls can be dangerous.

Due to high temperatures, the appliance should be located out of traffic and away from furniture and draperies.

Clothing or other flammable materials shall not be hung from the appliance or placed on or near the appliance. Never place any objects on the fireplace.

Appliance base assembly becomes very hot when running appliance.

⚠ DANGER: Carbon monoxide poisoning may lead to death!

Carbon Monoxide Poisoning: Early signs of carbon monoxide poisoning resemble the flu, with headaches, dizziness or nausea. If you have these signs, the fireplace may not be working properly. **Get fresh air at once!** Have heater serviced. Some people are more affected by carbon monoxide than others. These include pregnant women, people with heart or lung disease or anemia, those under the influence of alcohol and those at high altitudes.

Natural and Propane/LP Gas: Natural and propane/LP gases are odorless. An odor-making agent is added to the gas. The odor helps you detect a gas leak. However, the odor added to the gas can fade. Gas may be present even though no odor exists.

Make certain you read and understand all warnings. Keep this manual for reference. It is your guide to safe and proper operation of this fireplace.

⚠ WARNING: Do not place log scraps or volcanic stone on burner.

Children and adults should be alerted to the hazards of high surface temperatures and should stay away to avoid burns or clothing ignition. Appliance will remain hot for a time after shutdown. Allow surfaces to cool before touching.

Installation and repair should be done by a qualified service person. The appliance should be inspected before use and at least annually by a qualified service person. More frequent cleaning may be required as necessary. It is imperative that the control compartment, burners, and circulating air passageways of the appliance are kept clean.

SAFETY *Continued*

⚠ WARNING: Young children should be carefully supervised when they are in the area of the appliance. Toddlers, young children and others may be susceptible to accidental burns. A physical barrier is recommended if there are at-risk individuals in the house. To restrict access to a fireplace or stove, install an adjustable safety gate to keep toddlers, young children and other at-risk individuals out of the room and away from hot surfaces.

Carefully supervise young children when they are in the room with fireplace. When using the remote control, keep selector switch in the OFF position to prevent children from turning on burners with remote.

Keep the appliance area clear and free from combustible materials, gasoline and other flammable vapors and liquids.

⚠ WARNING: This appliance shall not be installed in a room or space unless the required volume of indoor combustion air is provided by the method described in the National Fuel Gas Code, ANSI Z223.1/NFPA 54, the International Fuel Gas Code.

Any part removed for servicing the appliance must be replaced prior to operating the appliance.

When installing as a vented appliance in a manufactured home or mobile home, the installation must conform with the Manufactured Home Construction and Safety Standard, Title 24 CFR, Part 3280 or when standard is not applicable, with *Manufacture Home Installations Standard*, ANSI/NCSBCS A225.1/NFPZ 501A.

WARNING: DO NOT INSTALL IN SLEEPING ROOM OF MOBILE HOMES.

You must operate this appliance with the fireplace screen in place. Make sure fireplace screen are in place before running appliance. The fireplace screen shall have openings for introduction of combustion air.

1. WARNING: This appliance is only for use with the type of gas indicated on the rating plate. This appliance is not convertible for use with other gases.

2. Do not place propane/LP supply tank(s) inside any structure. Locate propane/LP supply tank(s) outdoors (propane/LP units only).

3. If you smell gas
 - shut off gas supply
 - do not try to light any appliance
 - do not touch any electrical switch; do not use any phone in your building
 - leave the building immediately
 - immediately call your gas supplier from a neighbor's phone. Follow the gas supplier's instructions
 - if you cannot reach your gas supplier, call the fire department
4. This gas log set may not be installed in a bedroom or bathroom in the Commonwealth of Massachusetts.
5. Before installing in a solid fuel-burning fireplace, the chimney flue and firebox must be cleaned of soot, creosote, ashes and loose paint by a qualified chimney cleaner. Creosote will ignite if highly heated. A dirty chimney flue may create and distribute soot within the house. Inspect chimney flue for damage. If damaged, repair flue and firebox before operating appliance.
6. Make sure there are no obstructions across openings of fireplace.
7. To prevent the creation of soot, follow the instructions in *Cleaning and Maintenance*, Page 12.
8. Before using furniture polish, wax, carpet cleaner or similar products, turn appliance off. If heated, the vapors from these products may create a white powder residue within burner box or on adjacent walls and furniture.
9. Do not burn solid fuel in the fireplace after installation of this log set.
10. Do not operate appliance
 - where flammable liquids or vapors are used or stored
 - under dusty conditions
11. Do not use this appliance to cook food or burn paper or other objects.
12. Do not use this appliance if any part has been under water. Immediately call a qualified service technician to inspect the appliance and to replace any part of the control system and any gas control that has been under water.
13. Do not operate appliance if any log is broken.
14. Turn appliance off and let cool before servicing, installing or repairing. Only a qualified service person should install, service or repair appliance.
15. This appliance must not be connected to any external electrical source.
16. To prevent performance problems, do not use propane/LP fuel tank of less than 100 lb. capacity (propane/LP units only).
17. Provide adequate clearances around air openings.

LOCAL CODES

Install and use appliance with care. Follow all local codes. In the absence of local codes, use the latest edition of *The National Fuel Gas Code, ANSI Z223.1/NFPA 54**.

The appliance when installed, must be electrically grounded in accordance with local codes, or in the absence of local codes, with the *National Electrical Code, ANSI/NFPA 70**.

*Available from:

American National Standards Institute, Inc.
25 West 43rd Street, 4th floor
New York, NY 10036

National Fire Protection Association, Inc.
1 Batterymarch Park
Quincy, MA 02169-7471

SAFETY *Continued*

In the Commonwealth of Massachusetts:

- This appliance must be installed by a licensed plumber or gas fitter.
- The chimney flue damper, when used with gas logs, will be welded open or completely removed.
- A CO detector shall be installed in the room where the appliance is installed.

PRODUCT IDENTIFICATION



ASHTON WHITE BIRCH 24"



OZARK CHARRED OAK 24"



SMOKY WEATHERED OAK 24"

UNPACKING

1. Remove logs and appliance base assembly from carton(s).
2. Remove all protective packaging applied to logs and appliance for shipment.
3. Check appliance for any shipping damage. If appliance is damaged, promptly inform dealer where you purchased the appliance

⚠ CAUTION: Do not remove the data plates from the grate assembly. The data plates contain important warranty and safety information.

PRODUCT INFORMATION

This appliance is listed as a vented decorative gas appliance to ANSI Z21.60 for use indoors in wood burning fireplaces. It shall be installed indoors in a site built wood burning fireplace or a UL 127 listed wood burning fireplace.

ELECTRONIC IGNITION SYSTEM

This appliance has an electronic igniter to light appliance fuel supply.

INSTALLATION

⚠ WARNING: A qualified service person must install appliance. Follow all local codes.

⚠ WARNING: Make sure the selector switch is in the OFF position before installing appliance.

⚠ WARNING: Never install the appliance

- in a recreational vehicle
- where curtains, furniture, clothing or other flammable objects are less than the minimal distances required by the manufacturer
- in high traffic areas
- in windy or drafty areas

CHECK GAS TYPE

Gas type will be indicated on the burner and the box. Do not use a natural gas burner with propane or a propane burner with natural gas. If your gas supply is not the correct gas type, do not install appliance. Call dealer where you bought appliance for proper type appliance.

⚠ WARNING: This appliance assembly contains burner orifices specifically for the input gas specified on the burner and box, as well as the BTU rating specified in this manual. Modifying or failure to use the factory orifice may cause property damage, personal injury or loss of life.

⚠ WARNING: This appliance is equipped for either natural gas or propane/LP gas but not both. Gas type is indicated on the rating plate. Field conversion is not permitted.

INSTALLATION AND CLEARANCES

⚠ WARNING: Maintain the minimum clearances. If you can, provide greater clearances from floor, ceiling and adjoining wall.

NOTICE: Surface temperatures of adjacent walls and mantels become hot during operation. Walls and mantels above the firebox may become hot to the touch. If installed properly, these temperatures meet the requirement of the national product standard. Follow all minimum clearances shown in this manual.

NOTE: When installing your gas logs into a manufactured firebox, follow firebox manufacturer's instructions for minimum clearances to combustible materials.

LOG SET	MINIMUM FIREPLACE SIZE			
	WIDTH		DEPTH	HEIGHT
	FRONT	REAR		
ASHTONWHITEBIRCH24 OZARKCHARREDOAK24 SMOKYWEATHEREDOAK24	36"	24"	18"	24"
ASHTONWHITEBIRCH30 OZARKCHARREDOAK30 SMOKYWEATHEREDOAK30	42"	30"	18"	24"
ASHTONWHITEBIRCH36 OZARKCHARREDOAK36 SMOKYWEATHEREDOAK36	48"	36"	18"	24"

NOTE: Also certified with use of IHP Superior WRE4500, WRE6000, WRT4500 and WRT6000 fireplace models, and IHP Astria Georgian and Oracle Fireplace models. Follow minimum fireplace sizing guidelines as detailed in the chart below for these fireplace models.

LOG SET	MINIMUM FIREPLACE SIZE			
	WIDTH		DEPTH	HEIGHT
	FRONT	REAR		
ASHTONWHITEBIRCH24 OZARKCHARREDOAK24 SMOKYWEATHEREDOAK24	35-1/4"	22-1/2"	19"	24"
ASHTONWHITEBIRCH30 OZARKCHARREDOAK30 SMOKYWEATHEREDOAK30	41-3/8"	26-3/8"	21-3/4"	24"
ASHTONWHITEBIRCH36 OZARKCHARREDOAK36 SMOKYWEATHEREDOAK36	48"	34-3/8"	21-3/4"	24"

INSTALLING DAMPER CLAMP ACCESSORY FOR VENTED OPERATION

NOTE: Appliance must be installed only in a solid-fuel-burning fireplace with a working flue and constructed of noncombustible material. This unit may not be installed in a vented fireplace with a chimney height less than the minimum required by the manufacturer.

Appliance may be installed as a vented decorative appliance in compliance with ANSI Z21.60.

A permanent free opening must be provided by either the fireplace chimney or chimney damper to vent carbon monoxide and other flue gases. Any chimney damper must be fixed in a manner which will maintain the permanent free opening at all times. Use the Tables found on **Page 6** (For Factory Built Fireplaces and For Masonry Built Fireplaces Free Opening Area of Chimney Damper for Venting Combustion Products From Decorative Appliances For Installation in Solid Fuel Burning Fireplaces) to determine the minimum permanent free opening based on chimney height and the appliance BTU rating. The Damper Clamp (see **Figure A**) with bolt is provided as a means to prevent the full closure of the damper blade. The clamp is easily attached to most damper blades with pliers or a wrench, and must be permanently installed. The clamp is designed to prevent accidental closure of the damper when installed as pictured. Should the clamp not fit, or fail to provide the required permanent vent opening, do any of the following:

- Have a permanent stop installed
- Remove the damper blade
- Install a screw or bolt on the edge of the damper
- Weld damper in place

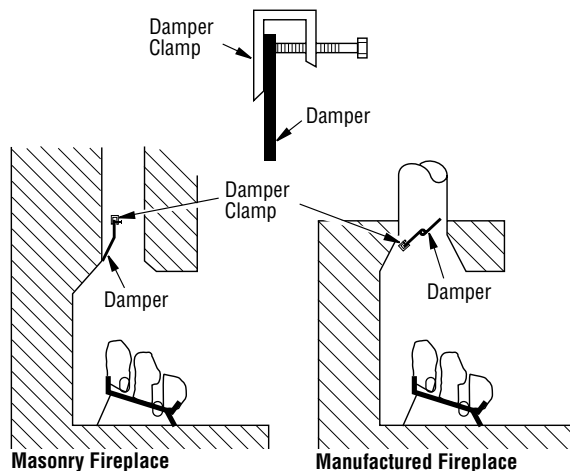

Figure A - Attaching Damper Clamp

INSTALLATION *Continued*

For Factory Built Fireplaces Free Opening Area of Chimney Damper for Venting Combustion Products From Decorative Appliances For Installation In Solid Fuel Burning Fireplaces												
	Appliance Input Rate (kBTU/hr)											
	20	30	40	50	60	70	80	90	100	110	120	
Chimney Height* (ft)	Minimum Opening** (sq. in.)											Max. Input***
10	11.3	16.6	22.1	28.3	35.3	44.2	---	---	---	---	---	77.6
15	8.6	12.6	17.3	21.2	26.4	32.2	38.5	45.4	---	---	---	98.2
20	7.5	10.8	14.5	18.1	22.1	26.4	31.2	37.4	43.0	---	---	114.2
25	6.6	9.6	12.6	15.9	18.1	22.9	27.3	31.2	36.3	43.0	50.3	121.0
30	6.2	9.1	11.3	14.5	17.3	20.4	24.6	28.3	33.2	37.4	44.2	130.1
35	5.7	8.0	10.8	13.2	15.9	18.9	22.1	25.5	30.2	34.2	39.6	141.2
40	5.3	7.5	10.2	12.6	15.2	18.1	20.4	23.8	27.3	31.2	35.3	158.5

* Height is from hearth to top of chimney and the minimum height is 10 feet.

** Chart shows mainimum opening (sq. in.) for the given height and input rate.

*** Column marked ("Max input" corresponds to the maximum allowable input rate (kBTU/hr) for the given height.

For Masonry Built Fireplaces Free Opening Area of Chimney Damper for Venting Combustion Products From Decorative Appliances For Installation In Solid Fuel Burning Fireplaces												
	Appliance Input Rate (kBTU/hr)											
	20	30	40	50	60	70	80	90	100	110	120	
Chimney Height* (ft)	Minimum Opening** (sq. in.)											
6	17.6	25.7	33.8	41.7	49.2	56.6	64.0	71.4	78.8	86.2	93.5	
8	16.5	23.7	31.2	38.7	45.5	52.4	59.7	66.9	74.1	81.3	88.6	
10	15.1	21.7	28.7	35.2	41.7	48.2	54.3	60.2	66.1	72.0	77.9	
15	14.1	19.9	26.1	32.0	37.7	43.2	48.8	54.1	59.4	64.6	69.9	
20	12.9	18.5	23.7	28.8	34.3	39.8	44.4	49.1	53.8	58.4	63.0	
30	12.2	16.9	21.6	26.5	31.2	35.9	40.3	44.5	48.6	52.7	56.6	

* Height is from hearth to top of chimney and the minimum height is 10 feet.

** Chart shows mainimum opening (sq. in.) for the given height and input

INSTALLATION *Continued*

For Massachusetts Residents Only: Installation of this gas log set as a vented indoor appliance in the Commonwealth of Massachusetts requires the damper be permanently removed or welded in the fully open position.

You must install the damper clamp accessory. This will ensure vented operation (see **Figure A on Page 5**). The damper clamp will keep damper open.

See chart below on **Page 6** for minimum permanent flue opening you must provide. Attach damper clamp so the minimum permanent flue opening will be maintained at all times.

INSTALLING APPLIANCE BASE ASSEMBLY

Clear fireplace of all debris. Center burner inside the fireplace left to right and push burner in the back as far back in the fireplace as possible.



CONNECTING TO GAS SUPPLY

⚠ WARNING: This appliance requires a 1/2" NPT (National Pipe Thread) inlet connection to the pressure regulator.

⚠ WARNING: A qualified service person must connect appliance to gas supply. Follow all local codes.

⚠ CAUTION: Never connect propane/LP appliance directly to the propane/LP supply. This appliance requires an external regulator (not supplied). Install the external regulator between the appliance and propane/LP supply.

⚠ WARNING: Never connect this appliance to private (non-utility) gas wells. This gas is commonly known as wellhead gas and does not have odorants and may have impurities, and variations in BTU content. The use of well-head gas will void the manufacturer's warranty to this appliance.

When an appliance is for connection to a fixed piping system, the installation must conform with local codes, or in the absence of local codes with the *National Fuel Gas Code, ANSI Z223.1 • NFPA 54; National Fuel Gas Code.*

Installation Items Needed

Before installing appliance, make sure you have the items listed below.

- external regulator (supplied by installer)
- piping (check local codes)
- sealant (resistant to propane/LP gas)
- equipment shutoff valve *
- test gauge connection *
- sediment trap
- tee joint
- pipe wrench
- approved flexible gas line with gas connector (if allowed by local codes) (not provided)

* An equipment shutoff valve with 1/8" NPT tap is an acceptable alternative to test gauge connection. Purchase the optional equipment shutoff valve from your dealer.

For propane/LP units, the installer must supply an external regulator. The external regulator will reduce incoming gas pressure. You must reduce incoming gas pressure to between 11" and 14" of water. If you do not reduce incoming gas pressure, appliance regulator damage could occur. Install external regulator with the vent pointing down as shown in **Figure B**. Pointing the vent down protects it from freezing rain or sleet.

⚠ CAUTION: Use only new, black iron or steel pipe. Internally-tinned copper tubing may be used in certain areas. Check your local codes. Use pipe of 1/2" diameter or greater to allow proper gas volume to appliance. If pipe is too small, undue loss of volume will occur.

Installation must include an equipment shutoff valve, union and plugged 1/8" NPT tap. Locate NPT tap within reach for test gauge hook up. NPT tap must be upstream from appliance (see **Figure C**).

IMPORTANT: Install equipment shutoff valve in an accessible location. The equipment shutoff valve is for turning on or shutting off the gas to the appliance.

Check your building codes for any special requirements for locating equipment shutoff valve to appliances.

Apply pipe joint sealant lightly to male NPT threads. This will prevent excess sealant from going into pipe. Excess sealant in pipe could result in clogged appliance valves.

⚠ WARNING: Use pipe joint sealant that is resistant to liquid petroleum (LP) gas.

INSTALLATION *Continued*

We recommend that you install a sediment trap in supply line as shown in **Figure C**. Locate sediment trap where it is within reach for cleaning.

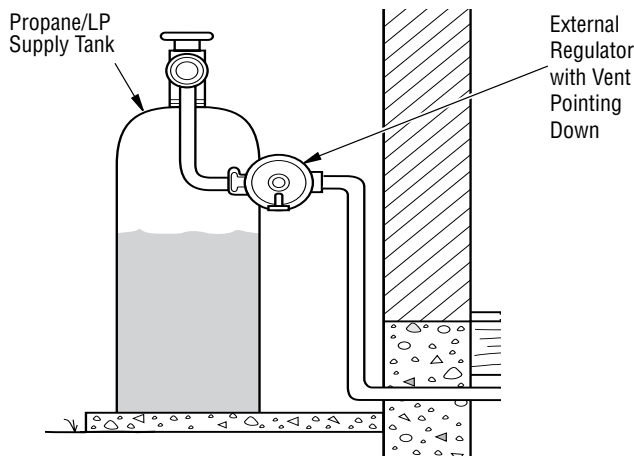
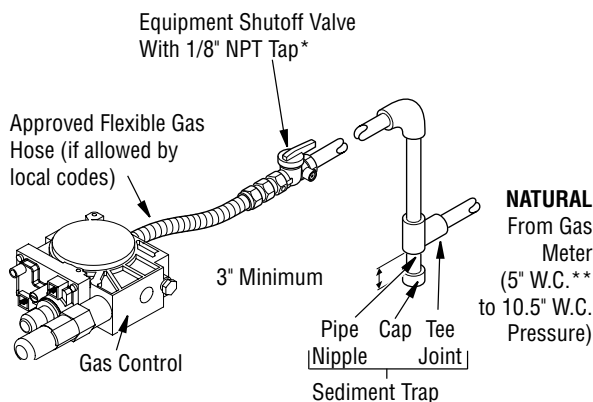

Figure B - External Regulator With Vent Pointing Down



* Purchase the optional equipment shutoff valve from your dealer.

**Minimum inlet pressure for purpose of input adjustment.

Figure C - Gas Connection

Install in piping system between fuel supply and appliance. Locate sediment trap where trapped matter is not likely to freeze. A sediment trap traps moisture and contaminants. This keeps them from going into appliance controls. If sediment trap is not installed or is installed wrong, appliance may not run properly.

CAUTION: Avoid damage to gas control. Hold gas control with wrench when connecting it to gas piping and/or fittings.

CHECKING GAS CONNECTIONS

WARNING: Test all gas piping and connections, internal and external to unit, for leaks after installing or servicing. Correct all leaks at once.

WARNING: Never use an open flame to check for a leak. Apply a noncorrosive leak detection fluid to all joints. Bubbles forming show a leak. Correct all leaks at once.

CAUTION: Make sure external regulator has been installed between propane/LP supply and appliance. See guidelines under **Connecting to Gas Supply, Page 7**.

PRESSURE TESTING GAS SUPPLY PIPING SYSTEM

The appliance and its appliance main gas valve must be disconnected from the gas supply piping system during any pressure testing of that system at test pressures **in excess of** 1/2 psi (3.5 kPa).

The appliance must be isolated from the gas supply piping system by closing its equipment shutoff valve during any pressure testing of the gas supply piping system at test pressures **equal to or less than** 1/2 psi (3.5 kPa).

Test Pressures In Excess Of 1/2 PSIG (3.5 kPa)

1. Disconnect appliance with its appliance main gas valve (control valve) and equipment shutoff valve from gas supply piping system. Pressures in excess of 1/2 psig will damage appliance regulator.
2. Cap off open end of gas pipe where equipment shutoff valve was connected.
3. Pressurize supply piping system by either opening propane/LP supply tank valve for propane/LP gas or opening main gas valve located on or near gas meter for natural gas or using compressed air.
4. Check all joints of gas supply piping system. Apply noncorrosive leak detection fluid to all joints. Bubbles forming show a leak.
5. Correct all leaks at once.
6. Reconnect appliance and equipment shutoff valve to gas supply. Check reconnected fittings for leaks.

Test Pressures Equal To or Less Than 1/2 PSIG (3.5 kPa)

1. Close equipment shutoff valve (*see Figure D*).
2. Pressurize supply piping system by either opening propane/LP supply tank valve for propane/LP gas or opening main gas valve located on or near gas meter for natural gas or using compressed air.
3. Check all joints from gas meter to equipment shutoff valve for natural gas or propane/LP supply to equipment shutoff valve for propane/LP (*see Figure E*). Apply noncorrosive leak detection fluid to all joints. Bubbles forming show a leak.
4. Correct all leaks at once.

PRESSURE TESTING APPLIANCE GAS CONNECTIONS

1. Open equipment shutoff valve (*see Figure D*).
2. Open main gas valve located on or near gas meter for natural gas or open propane/LP supply tank valve.
3. Make sure control knob of appliance is in the OFF position.
4. Check all joints from gas meter to equipment shutoff valve for natural gas or propane/LP supply to equipment shutoff valve for propane/LP (*see Figure E or Figure F, Page 9*). Apply noncorrosive leak detection fluid to all joints. Bubbles forming show a leak.
5. Correct all leaks at once.
6. Light appliance (*see Remote Lighting, Page 11*). Check all other internal joints for leaks.
7. Turn off appliance (*see Shutting Down, Page 11*).

INSTALLATION *Continued*

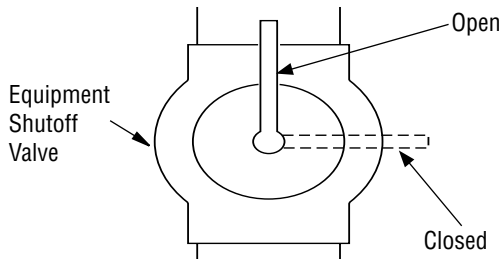

Figure D - Equipment Shutoff Valve

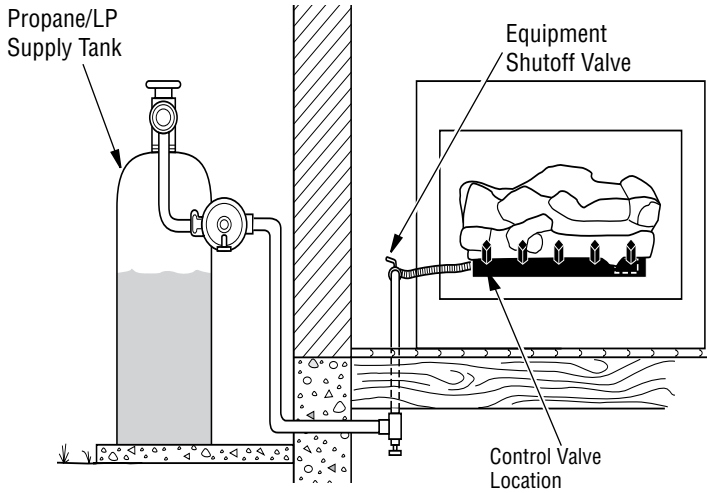

Figure E - Checking Gas Joints (Propane/LP Only)

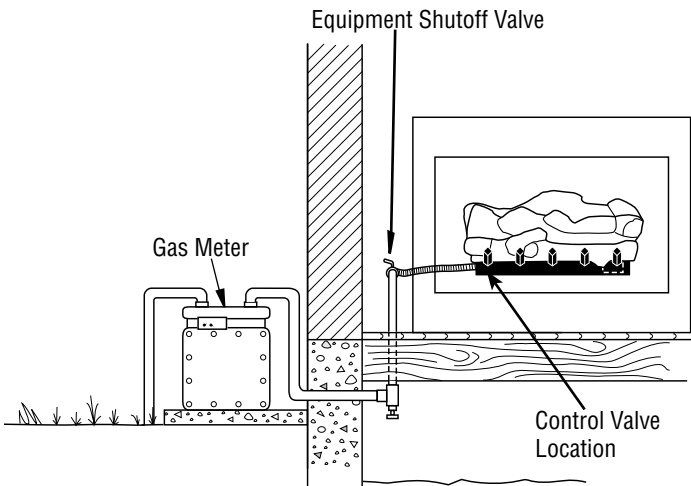

Figure F - Checking Gas Joints (Natural Gas Only)

INSTALLING LOGS AND MEDIA PLACEMENT

⚠ WARNING: Failure to position the parts in accordance with these diagrams or failure to use only parts specifically approved with this appliance may result in property damage or personal injury.

LOG/MEDIA PLACEMENT

It is very important to install these logs exactly as instructed. Do not modify logs. **Please refer to specific Log Placement Guides placed inside each Log Set.**

DUALBURNER24/30/36-NE/PE BURNER SYSTEM LOG COMPATIBILITY CHART	
Burner System Model	Log Sets For Use With This Burner System
DUALBURNER24NE DUALBURNER24PE	ASHTONWHITEBIRCH24 OZARKCHARREDOAK24 SMOKYWEATHEREDOAK24
DUALBURNER30NE DUALBURNER30PE	ASHTONWHITEBIRCH30 OZARKCHARREDOAK30 SMOKYWEATHEREDOAK30
DUALBURNER36NE DUALBURNER36PE	ASHTONWHITEBIRCH36 OZARKCHARREDOAK36 SMOKYWEATHEREDOAK36

MEDIA PLACEMENT - NATURAL GAS

Tear ember material into pieces the size of a corn kernel and place fingernail deep. Use either a comb or brush to achieve this. The smaller the piece, the better the ember glow. Spread the embers across the front burner and fill up the pan. The front burner should be completely covered. Dump lava rock around the burner covering the hearth.



BATTERY LIGHTING INSTRUCTIONS

FOR YOUR SAFETY, READ BEFORE LIGHTING

WARNING: If you do not follow these instructions exactly, a fire or explosion may result causing property damage, personal injury or loss of life.

- A. This appliance is equipped with an ignition device that automatically lights the pilot. DO NOT attempt to light the pilot by hand.
- B. BEFORE OPERATING, smell all around the appliance area for gas. Be sure to smell next to the floor because some gas is heavier than air and will settle on the floor.

WHAT TO DO IF YOU SMELL GAS

- Do not light any appliance.
- Do not touch any electric switch; do not use any phone in your building.
- Immediately call your gas supplier from a neighbor's phone. Follow the gas supplier's instructions. If you cannot reach your gas supplier, call the fire department.

- C. Use only the remote to light the pilot. This valve will not operate if the pilot is not lit and stable.
- D. Do not use this appliance if any part has been under water. Immediately call a qualified service technician to inspect the appliance and to replace any part of the control system and any gas control which has been under water. Attempted operation may result in fire or explosion resulting in property damage, personal injury or loss of life.

REMOTE LIGHTING

CAUTION: DO NOT attempt to light the pilot by hand.

Note: If the remote does not function, and batteries with an adequate power level are installed, refer to the TRANSMITTER FUNCTION section.

Note: Step 1 may not be required if previously done during an earlier lighting.

1. Locate the 3-position switch on the remote receiver and slide the switch to the REMOTE position.
2. Locate the remote transmitter and press the ON button. The ignition sequence will begin. The remote receiver will emit an audible "beep"; then the igniter will begin to spark. After the pilot lights and is established, the valve will automatically open and the burner will light.

Note: The ignition sequence will take approximately 5 seconds.

WARNING: If the pilot fails to light or if the burner fails to light (within 5 seconds of pilot lighting), press the OFF button on the remote transmitter and/or slide the switch to the OFF position. Allow five (5) minutes for any gas in the unit to dissipate, then repeat steps 1 and 2 above. IF YOU SMELL GAS, SEE STEP B ABOVE.

If the pilot fails to light after several tries, turn all control/remote system components to OFF and contact a qualified professional service technician.

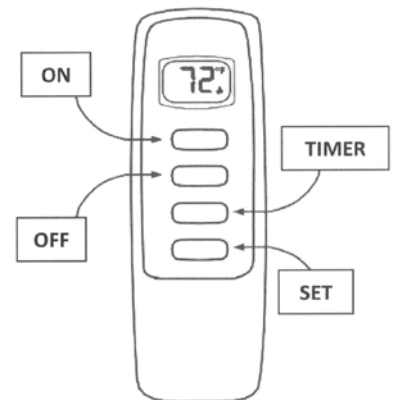
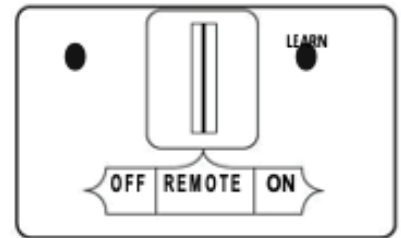

SHUTTING DOWN

For remote shut down, press the **OFF** button on the remote transmitter.

If remote is unavailable, slide the switch on the remote receiver to the **OFF** position.

PILOT APPEARANCE

Periodically check the pilot for proper flame pattern. The pilot flame should encircle the generator tip, and is reset at the factory.

If the pilot flame burns incorrectly; shut down completely and contact a qualified professional technician.

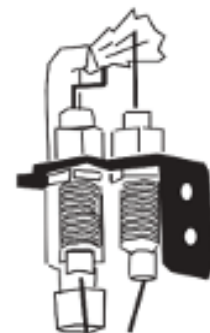

Battery Pilot

OPERATION *Continued*

ELECTRONIC BATTERY MODELS

Page 11 provides detailed lighting instructions along with the information below.

1. Battery Electronic 6V system burner can be operated by the remote or by the slider switch located on the remote receiver box.
2. First, insert D Cell Batteries (qty 2) into the battery pack located in the black box on the right hand side of the burner
3. Second, insert the AA Batteries (qty 4) into the receiver, which is attached to the battery pack on the right hand side of the burner
4. Next, insert the AAA Batteries (qty 2) into the hand held transmitter/remote
5. Locate the switch on the front of the receiver
6. Slide the switch from "OFF" to "REMOTE" mode, this now allows ON/OFF operations with the hand held remote
7. Follow remote instructions for battery placement and how to sync remote to receiver

⚠ WARNING: Glass doors shall be fully open when appliance is in operation.

CLEANING AND MAINTENANCE

⚠ WARNING: Turn off appliance and let cool before cleaning.

⚠ CAUTION: You must keep control areas, burners and circulating air passageways of appliance clean. Inspect these areas of appliance before each use. Have appliance inspected yearly by a qualified service person.

⚠ WARNING: Failure to keep the primary air opening(s) of the burner(s) clean may result in sooting and property damage.

BURNER INJECTOR HOLDER AIR INLET HOLE

The primary air inlet holes allow the proper amount of air to mix with the gas. Keep these holes clear of dust, dirt, lint and pet hair. Clean these air inlet holes prior to each heating season. Blocked air holes will create soot. We recommend that you clean the unit every three months during operation and have appliance inspected yearly by a qualified service person.

We also recommend that you keep the burner tube clean and free of dust and dirt. To clean these parts we recommend using compressed air no greater than 30 PSI. Your local computer store, hardware store or home center may carry compressed air in a can. If using compressed air in a can, please follow the directions on the can. If you don't follow directions on the can, you could damage the pilot assembly.

1. Shut off unit. Allow unit to cool for at least thirty minutes.
2. Inspect burner, and primary air inlet holes on injector holder for dust and dirt.
3. Blow air through the ports/slots and holes in the burner.

4. Check injector holder located at end of burner tube again. Remove any large particles of dust, dirt, lint or pet hair with a soft cloth or vacuum cleaner nozzle.
5. Blow air into the primary air holes on the injector holder.
6. In case any large clumps of dust have now been pushed into the burner repeat steps 3 and 4. Additional cleaning may be needed for proper operation based on use/lack of use.

LOGS

- If you remove logs for cleaning, refer to *Installing Logs and Media Placement, Page 10* to properly replace logs.
- Replace log(s) if broken or chipped (dime-sized or larger).

MAIN BURNER

Periodically inspect all burner flame holes with appliance running. All slotted burner flame holes should be open with flame present. All round burner flame holes should be open with a small blue flame present. Some burner flame holes may become blocked by debris or rust, with no flame present. If so, turn off appliance and let cool. Remove blockage, blocked burner flame holes will create soot.

The burner must be replaced prior to the appliance being put into operation if it is evident that the burner is damaged (use only factory original replacement burner).

At least once a year, the vent system for the fireplace in which this appliance is installed shall be inspected, cleaned, and repaired as necessary by a qualified service person.

SPECIFICATIONS

Models	Natural Gas	Propane/Lp Gas
	High Rate	High Rate
DUALBURNER24NE	55,000	---
DUALBURNER24PE	---	50,000
DUALBURNER30NE	70,000	---
DUALBURNER30PE	---	65,000
DUALBURNER36NE	80,000	---
DUALBURNER36PE	---	75,000

OPERATION *Continued*

WIRING DIAGRAM INSTALLATION

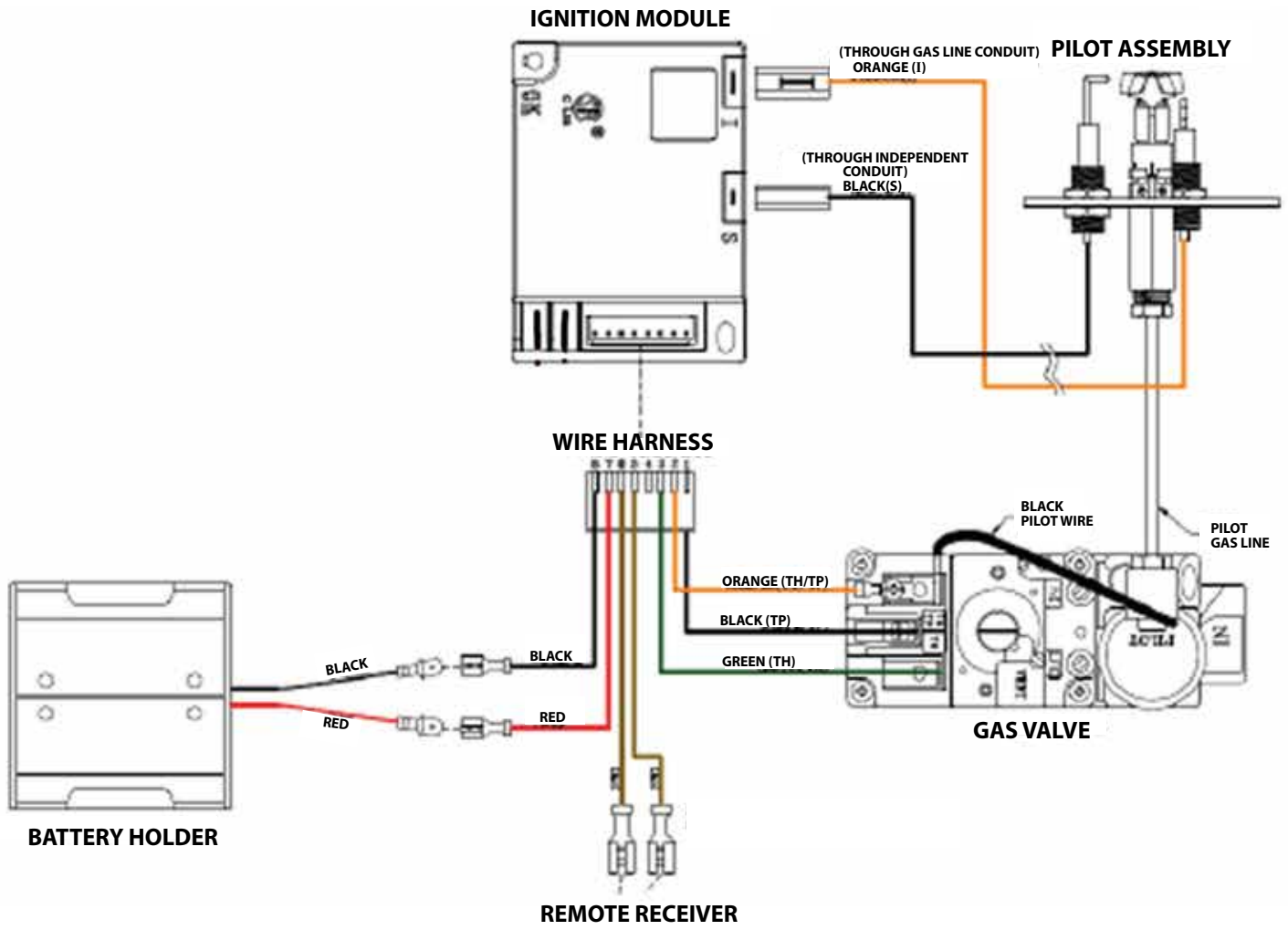

TRANSMITTER

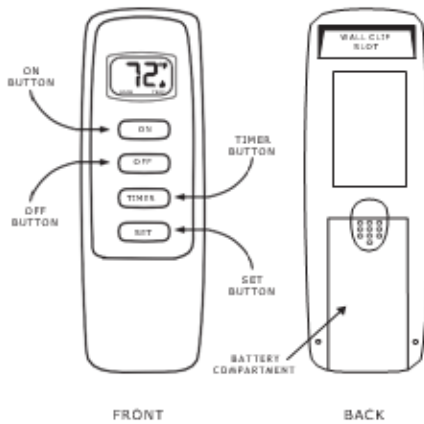

The transmitter operates on (2) 1.5V AAA batteries. It is recommended that ALKALINE batteries always be used for this product. **Be sure the batteries are installed with the (+) and (-) ends facing the correct direction, and are fully charged.**

KEY SETTINGS

1. ON --- Turns appliance ON.
2. OFF -- Turns appliance OFF.
3. TIMER Changes unit from manual mode to timer mode.
4. SET -- Adjusts timer setting.

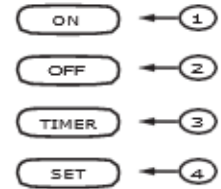

LCD - LIQUID CRYSTAL DISPLAY

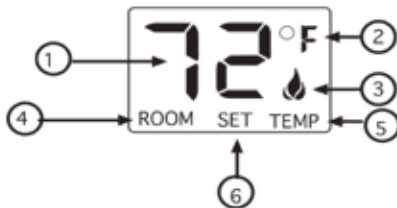

1. Display ----- Indicates current room temperature.
2. Fahrenheit or Celsius Indicates degrees Fahrenheit or Celsius.
3. Flame ----- Indicates appliance is ON.
4. Room ----- Appears when LCD screen is ON.
5. Temperature ----- Appears during manual operation.
6. Set ----- Appears when adjusting the desired timer setting.

SETTING °FAHRENHEIT / °CELSIUS SCALE

The factory setting for temperature is °F. To change the displayed temperature scale, press the ON and OFF keys at the same time. Follow this same procedure to return to °F.



MANUAL FUNCTION

ON OPERATION:

Press the ON key to turn the appliance ON. (The flame icon will appear on the LCD screen).



ON MODE

OFF OPERATION:

Press the OFF key to turn the appliance OFF. (The flame icon will disappear from the LCD screen).



OFF MODE

TIMER FUNCTION

- Press the ON button to start the appliance.
- Press the TIMER button. The LCD screen will show the word set.
- Press the SET button until the desired time is reached (15 min. - 180 min. In 15 minute increments). The max setting time is 3 hours.
- NOTE: The LCD display will flash the set time for 6-seconds, then start the countdown.
- Press the OFF button to turn OFF the timer, and the appliance.



SET MODE



COUNT DOWN MODE

LEARNING TRANSMITTER TO RECEIVER

Each transmitter uses a unique security code. It will be necessary to press the LEARN button on the receiver to accept the transmitter security code upon initial use, if batteries are replaced, or if a replacement transmitter is purchased from your dealer or the factory. In order for the receiver to accept the transmitter security code, be sure the slide button on the receiver is in the REMOTE position; the receiver will not LEARN if the slide switch is in the ON or OFF position. The LEARN button is located on the front face of the receiver; inside the small hole labeled LEARN. Using a small screwdriver or end of a paperclip gently press and release the black LEARN button inside the hole. When you release the LEARN button the receiver will emit an audible "beep". After the receiver emits the beep press the transmitter ON button and release. The receiver will emit several beeps indicating that the transmitter's code has been accepted into the receiver.

TROUBLESHOOTING

⚠ WARNING: Turn off appliance and let cool before servicing. Only a qualified service person should service and repair appliance.

NOTE: All troubleshooting items are listed in order of operation.

OBSERVED PROBLEM	POSSIBLE CAUSE	REMEDY
Delayed ignition of burner	<ol style="list-style-type: none"> 1. Manifold pressure is too low 2. Burner orifice clogged 	<ol style="list-style-type: none"> 1. Contact local natural or propane/LP gas company 2. Clean burner (<i>see Cleaning and Maintenance, Page 12</i>) or replace burner orifice(s)
Burner backfiring during combustion	<ol style="list-style-type: none"> 1. Burner orifice is clogged or damaged 2. Damaged burner 	<ol style="list-style-type: none"> 1. Clean burner (<i>see Cleaning and Maintenance, Page 12</i>) or replace burner orifice 2. Replace damaged burner
Slight smoke or odor during initial operation	<ol style="list-style-type: none"> 1. Residues from manufacturing processes and logs curing 	<ol style="list-style-type: none"> 1. Problem will stop after a few hours of operation
Appliance produces a whistling noise when burners are lit	<ol style="list-style-type: none"> 1. Air in gas line 2. Air passageways on appliance blocked 3. Dirty or partially clogged burner orifice. 4. Flex line has kink 	<ol style="list-style-type: none"> 1. Operate burners until air is removed from line. Have gas line checked by local natural or propane/LP gas company 2. Observe minimum installation clearances (<i>see Page 6</i>) 3. Clean burner (<i>see Cleaning and Maintenance, Page 12</i>) or replace burner orifice(s) 4. Straighten flexible connector
White powder residue forming within burner box or on adjacent walls or furniture	<ol style="list-style-type: none"> 1. When heated, vapors from furniture polish, wax, carpet cleaners, etc. may turn into white powder residue 	<ol style="list-style-type: none"> 1. Turn appliance off when using furniture polish, wax, carpet cleaners or similar products
Remote does not function	<ol style="list-style-type: none"> 1. Batteries are not installed. Battery power is low 	<ol style="list-style-type: none"> 1. Replace batteries in battery pack and in hand-held remote

⚠ WARNING: If you smell gas

- Shut off gas supply.
- Do not try to light any appliance.
- Do not touch any electrical switch; do not use any phone in your building.
- Immediately call your gas supplier from a neighbor's phone. Follow the gas supplier's instructions.
- If you cannot reach your gas supplier, call the fire department.

IMPORTANT: Operating appliance where impurities in air exist may create odors. Cleaning supplies, paint, paint remover, cigarette smoke, cements and glues, new carpet or textiles, etc., create fumes. These fumes may mix with combustion air and create odors. These odors will disappear over time.

OBSERVED PROBLEM	POSSIBLE CAUSE	REMEDY
Appliance produces unwanted odors	<ol style="list-style-type: none"> 1. Appliance burning vapors from paint, hair spray, glues, cleaners, chemicals, new carpet, etc. (<i>See IMPORTANT statement above</i>) 2. Low fuel supply (propane/LP only) 3. Gas leak. See Warning: If you smell gas statement above 	<ol style="list-style-type: none"> 1. Open window to ventilate room. Stop using odor causing products while appliance is running 2. Refill supply tank (propane/LP only) 3. Locate and correct all leaks (<i>see Checking Gas Connections, Page 8</i>)
Appliance shuts off in use	<ol style="list-style-type: none"> 1. Low line pressure 	<ol style="list-style-type: none"> 1. Contact local natural or propane/LP gas company
Gas odor even when control knob is in OFF position	<ol style="list-style-type: none"> 1. Gas leak. See Warning: If you smell gas statement above 2. Control valve or gas control defective 	<ol style="list-style-type: none"> 1. Locate and correct all leaks (<i>see Checking Gas Connections, Page 8</i>) 2. Replace control valve or gas control
Gas odor during combustion	<ol style="list-style-type: none"> 1. Gas leak. See Warning: If you smell gas statement above 	<ol style="list-style-type: none"> 1. Locate and correct all leaks (<i>see Checking Gas Connections, Page 8</i>)

TROUBLESHOOTING
Continued

OBSERVED PROBLEM	POSSIBLE CAUSE	REMEDY
<p>Battery Electronic System is turned ON but not sparking</p>	<ol style="list-style-type: none"> 1. Weak batteries or bad AC adapter 2. A shorted or loose connection in the wiring configuration or wire harness 3. Improper wall switch or remote wiring 4. Poor ground 5. Faulty module 	<ol style="list-style-type: none"> 1. Replace batteries 2. Verify wiring per wiring diagram 3. Verify wiring per wiring diagram 4. Verify wiring per wiring diagram 5. Replace module
<p>Battery Electronic Pilot lights but the system continues to spark</p>	<ol style="list-style-type: none"> 1. Poor flame rectification or contaminated sensor rod 2. Module is not grounded 3. Damaged pilot assembly 4. Too large of a gap in sensor rod 	<ol style="list-style-type: none"> 1. Clean sensor rod 2. Verify wiring 3. Replace pilot assembly 4. Verify sensor rod needs to have a 1/8" gap
<p>Appliance produces a clicking/ticking noise just after burners are lit or shut off</p>	<ol style="list-style-type: none"> 1. Metal expanding while heating or contracting while cooling 2. Igniter Assembly is out of position 3. Wind is disturbing the burner flame and the igniter assembly is relighting the burner 4. Wire connection loose or wire broken 	<ol style="list-style-type: none"> 1. This is normal with most appliances. If noise is excessive, contact qualified service person 2. Check igniter position and adjust if needed. 3. Should wind disturb the burner flame, the igniter will automatically spark to relight the burner. This is normal when the appliance is installed outdoors in windy conditions 4. Check wiring connections (<i>see wiring diagram, Page 13</i>). Replace wire harness if necessary

REPLACEMENT PARTS

See **Pages 18-19** for a complete replacement parts list. Use only parts supplied from the manufacturer.

Normally, all parts should be ordered through your IHP distributor or dealer. Parts will be shipped at prevailing prices at time of order.

When ordering repair parts, always give the following information:

1. The model number of the appliance.
2. The serial number of the appliance.
3. The part number.
4. The description of the part.
5. The quantity required.
6. The installation date of the appliance.

If you encounter any problems or have any questions concerning the installation or application of this appliance, please contact your dealer

IHP

**1769 East Lawrence Street
Russellville, AL 35654
Visit us at ihp.us.com**

SERVICE HINTS

When Gas Pressure Is Too Low

- pilot will not stay lit
- burners will have delayed ignition
- appliance will not produce specified heat
- propane/LP gas supply may be low

You may feel your gas pressure is too low. If so, contact your local propane/LP or natural gas supplier.

TECHNICAL SERVICE

You may have further questions about installation, operation, or troubleshooting. Please contact your IHP dealer for any questions or concerns. When contacting your dealer please have your model and serial numbers of your appliance ready. You can also visit our web site at ihp.us.com.

PARTS

MODELS: DUALBURNER24NE, DUALBURNER24PE, DUALBURNER30NE, DUALBURNER30PE, DUALBURNER36NE AND DUALBURNER36PE.

⚠ WARNING: Failure to position the parts in accordance with these diagrams or failure to use only parts specifically approved with this heater may result in property damage or personal injury.

Cat. No.	Model
F4744	DUALBURNER24NE
F4745	DUALBURNER24PE
F4748	DUALBURNER30NE
F4749	DUALBURNER30PE
F4752	DUALBURNER36NE
F4753	DUALBURNER36PE

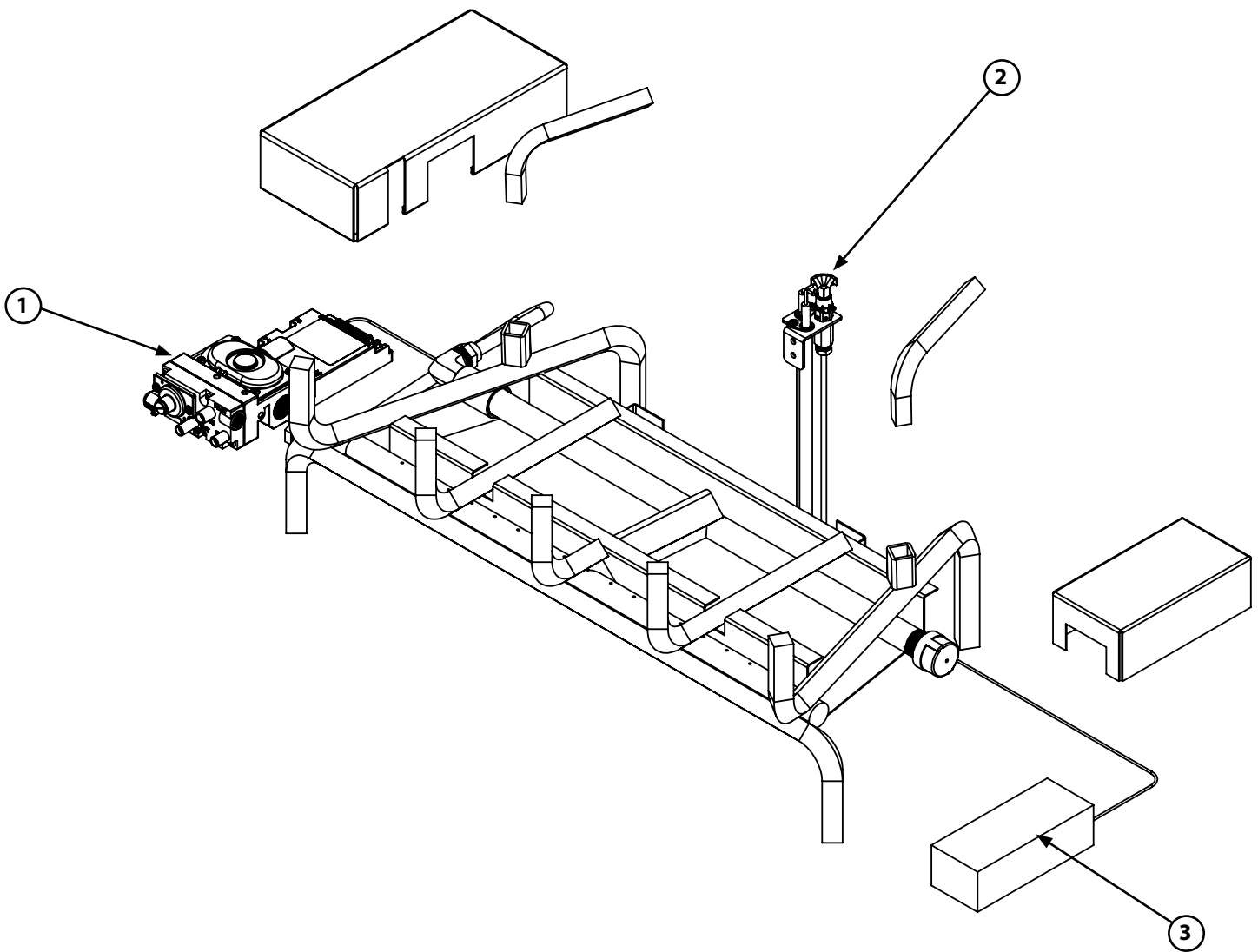

PARTS

MODELS: DUALBURNER24N, DUALBURNER24NE, DUALBURNER24PE, DUALBURNER30N, DUALBURNER30NE, DUALBURNER30PE, DUALBURNER36N, DUALBURNER36NE AND DUALBURNER30PE.

This list contains replaceable parts used in your appliance. When ordering parts, follow the instructions listed under [Replacement Parts](#) on *Page 17* of this manual.

⚠ WARNING: Contact an IHP dealer to obtain any of these parts. Never use substitute materials not approved by IHP. Use of non-approved parts can result in poor performance and safety hazards.

KEY NO.	CAT. NO.	DESCRIPTION							Qty.
			DUALBURNER24NE	DUALBURNER24PE	DUALBURNER30NE	DUALBURNER30PE	DUALBURNER36NE	DUALBURNER36PE	
1	F4789	Valve, NG Battery Electronic Model	X		X		X		1
1	F4790	Valve, LP Battery Electronic Model		X		X		X	1
2	F4791	Pilot, NG Battery Electronic Model	X		X		X		1
2	F4792	Pilot, LP Battery Electronic Model		X		X		X	1
3	F4793	Module, Electronic Models	X	X	X	X	X	X	1

PARTS

LOG SET MODELS

ASHTONWHITEBIRCH24, ASHTONWHITEBIRCH30, ASHTONWHITEBIRCH36, OZARKCHARREDOAK24, OZARKCHARREDOAK30, OZARKCHARREDOAK36, SMOKYWEATHEREDOAK24, SMOKYWEATHEREDOAK30, AND SMOKYWEATHEREDOAK36

This list contains replaceable parts used in your appliance. When ordering parts, follow the instructions listed under [Replacement Parts](#) on *Page 17* of this manual.

CAT. NO.	MODEL	DESCRIPTION
F4739	ASHTONWHITEBIRCH24	24" ASHTON WHITE BIRCH LOGS 7 PCS SET
F4740	ASHTONWHITEBIRCH30	30" ASHTON WHITE BIRCH LOGS 8 PCS SET
F4741	ASHTONWHITEBIRCH36	36" ASHTON WHITE BIRCH LOGS 9 PCS SET
F4736	OZARKCHARREDOAK24	24" OZARK CHARRED OAK LOGS 8 PCS SET
F4737	OZARKCHARREDOAK30	30" OZARK CHARRED OAK LOGS 9 PCS SET
F4738	OZARKCHARREDOAK36	36" OZARK CHARRED OAK LOGS 10 PCS SET
F4733	SMOKYWEATHEREDOAK24	24" SMOKY WEATHERED OAK LOGS 7 PCS SET
F4734	SMOKYWEATHEREDOAK30	30" SMOKY WEATHERED OAK LOGS 8 PCS SET
F4735	SMOKYWEATHEREDOAK36	36" SMOKY WEATHERED OAK LOGS 9 PCS SET

Innovative Hearth Products Gas Log Set Limited Three Year Warranty

THE WARRANTY

Innovative Hearth Products Limited Three Year Warranty ("IHP") warrants your IHP Gas Log Set ("Product") to be free from defects in materials and workmanship at the time of manufacture. The logs and grate carry the Limited Three Year Warranty. After installation, if covered components manufactured by IHP are found to be defective in materials or workmanship during the Limited Three Year Warranty period and while the Product remains at the site of the original installation, IHP will, at its option, repair or replace the covered components. If repair or replacement is not commercially practical, IHP will, at its option, refund the purchase price or wholesale price of the IHP product, whichever is applicable. IHP will also pay IHP prevailing labor rates, as determined in its sole discretion, incurred in repairing or replacing such components. THERE ARE EXCLUSIONS AND LIMITATIONS to this Limited Three Year Warranty as described herein.

COVERAGE COMMENCEMENT DATE

Warranty coverage begins on the date of purchase. In the case of new home construction, warranty coverage begins on the date of first occupancy of the dwelling or six months after the sale of the Product by an independent IHP dealer, whichever occurs earlier. The warranty shall commence no later than 24 months following the date of product shipment from IHP, regardless of the installation or occupancy date.

EXCLUSIONS AND LIMITATIONS

This Limited Three Year Warranty applies only if the Product is installed in the United States or Canada and only if operated and maintained in accordance with the printed instructions accompanying the Product and in compliance with all applicable installation and building codes and good trade practices.

This warranty is non-transferable and extends to the original owner only. The Product must be purchased through a listed supplier of IHP and proof of purchase must be provided. The following do not carry the Limited Three Year Warranty but are warranted as follows:

- Gas components** – Repair or replacement for one year from the date of installation.
- Remote control** – Repair or replacement for one year from the date of installation.
- Labor coverage** – Prevailing IHP labor rates apply for the warranty period of the component.

Parts not otherwise listed carry a 90 day warranty from the date of installation.

Whenever practicable, IHP will provide replacement parts, if available, for a period of 10 years from the last date of manufacture of the product.

IHP will not be responsible for: (a) damages caused by normal wear and tear, accident, riot, fire, flood or acts of God; (b) damages caused by abuse, negligence, misuse, or unauthorized alteration or repair of the Product affecting its stability or performance (The Product must be subjected to normal use. The Product is designed to burn either natural or propane gas only. Burning conventional fuels such as wood, coal or any other solid fuel will cause damage to the Product, will produce excessive temperatures and could result in a fire hazard.); (c) damages caused by failing to provide proper maintenance and service in accordance with the instructions provided with the Product; (d) damages, repairs or inefficiency resulting from faulty installation or application of the Product.

This Limited Three Year Warranty covers only parts and labor as provided herein. In no case shall IHP be responsible for materials, components or construction which are not manufactured or supplied by IHP or for the labor necessary to install, repair or remove such materials, components or construction. Additional utility bills incurred due to any malfunction or defect in equipment are not covered by this warranty. All replacement or repair components will be shipped F.O.B. from the nearest stocking IHP factory.

LIMITATION ON LIABILITY

It is expressly agreed and understood that IHP's sole obligation and the purchaser's exclusive remedy under this warranty, under any other warranty, expressed or implied, or in contract, tort or otherwise, shall be limited to replacement, repair, or refund, as specified herein.

In no event shall IHP be liable for any incidental or consequential damages caused by defects in the Product, whether such damage occurs or is discovered before or after replacement or repair, and whether such damage is caused by IHP's negligence. IHP has not made and does not make any representation or warranty of fitness for a particular use or purpose, and there is no implied condition of fitness for a particular use or purpose.

IHP makes no expressed warranties except as stated in this Limited Three Year Warranty. The duration of any implied warranty is limited to the duration of this expressed warranty.

No one is authorized to change this Limited Three Year Warranty or to create for IHP any other obligation or liability in connection with the Product. Some states and provinces do not allow the exclusion or limitation of incidental or consequential damages, so the above limitations or exclusions may not apply to you. The provisions of this Limited Three Year Warranty are in addition to and not a modification of or subtraction from any statutory warranties and other rights and remedies provided by law.

INVESTIGATION OF CLAIMS AGAINST WARRANTY

IHP reserves the right to investigate any and all claims against this Limited Three Year Warranty and to decide, in its sole discretion, upon the method of settlement.

To receive the benefits and advantages described in this Limited Three Year Warranty, the appliance must be installed and repaired by a licensed contractor approved by IHP.

Contact IHP at the address provided herein to obtain a listing of approved dealers/distributors. **IHP shall in no event be responsible for any warranty work done by a contractor that is not approved without first obtaining IHP's prior written consent.**

HOW TO REGISTER A CLAIM AGAINST WARRANTY

In order for any claim under this warranty to be valid, you must contact the IHP dealer/distributor from which you purchased the product. If you cannot locate the dealer/distributor, then you must notify IHP in writing. IHP must be notified of the claimed defect in writing within 90 days of the date of failure. Notices should be directed to the IHP Warranty Department at 1769 East Lawrence Street, Russellville, AL 35654 or visit our website at www.IHP.US.COM.

ihp.us.com

Record the following important information about your appliance:

Appliance model number	
Appliance serial number	
Date appliance was Installed	
Type of gas appliance uses	
Dealer name	

Innovative Hearth Products (IHP) reserves the right to make changes at any time, without notice, in design, materials, specifications, prices and also to discontinue colors, styles and products. Consult your local distributor for fireplace code information.

Printed in U.S.A. © 2022 Innovative Hearth Products
P/N 901174-00 Rev. B 04/2022



1769 East Lawrence Street • Russellville, AL 35654