

Eleviia

Nomenclature

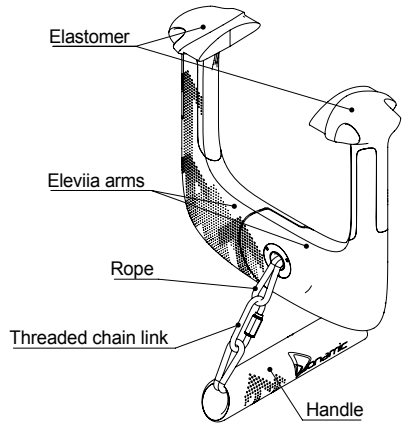

Door frame inspection

Eleviia may only be used with doors that comply with the building code, and only within the range of dimensions shown:

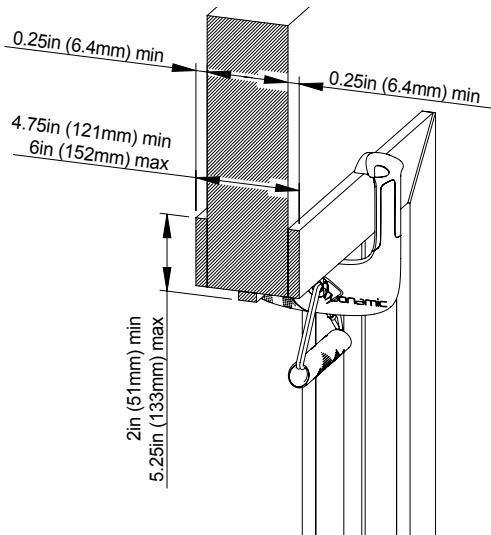

Installation

When installing Eleviia, make sure that each unit is attached to the door trim on both sides of the door:

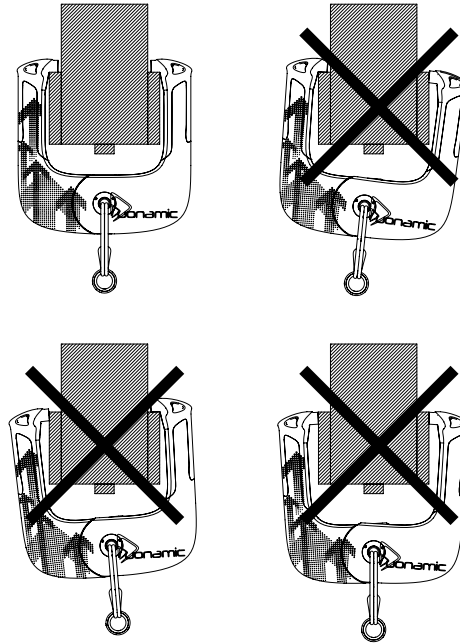

After installing Eleviia, check that it is secure by gradually transferring your weight onto the handles until your feet are a few inches off the floor.

Always use both Eleviia when exercising:

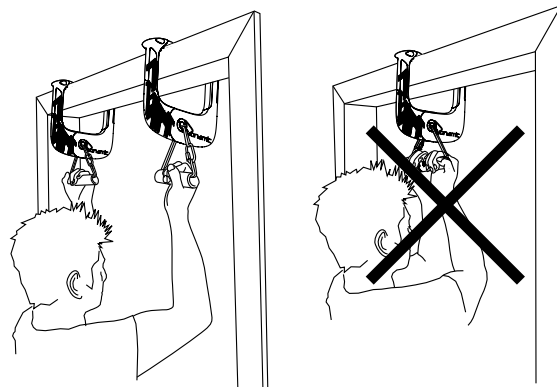

Do not use the arms of Eleviia as a handle:

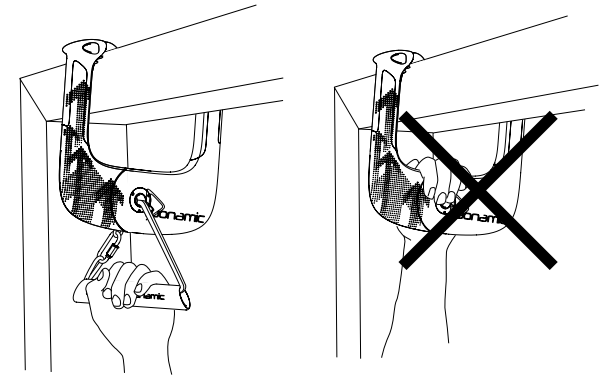

Before exercise, check that the threaded chain link on each Eleviia unit is fully closed and tightened:

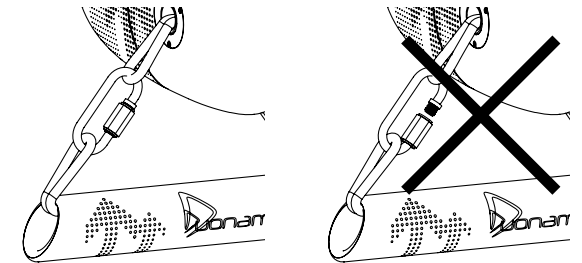

Specifications

Maximum user weight	250lb (113kg)
Weight	3.5lb (1.6kg)
Dimensions	10in x 9in x 4.5in (25cm x 23cm x 11cm)

Safety Information

Exercises involving the use of Duonamic Eleviia are inherently dangerous. You are responsible for your safety and the property around you while using this equipment. Failure to read and follow the safety instructions stated in this owner's manual may result in serious injury, death or property damage.

1) It is your responsibility to ensure that each door you use Eleviia on is suitable for the application. It must be dimensionally compatible with Eleviia, compliant with the building code, and structurally capable of supporting your weight during exercise. After installing Eleviia, gradually apply your weight on the handles until you are hanging with your feet just a few inches off the floor. During this process, listen and feel for any squeaks or other sounds from the door frame which may signal that it is not strong enough to support your weight. If you tear down your door trim or otherwise damage your or someone else's property by using Eleviia, it is your responsibility and liability.

2) Do not use Eleviia if you weigh more than 250 lbs (113kg).

3) Before each use of Eleviia, inspect it for damage and make sure it is properly configured. Ensure that the arms freely and smoothly pivot within their range of motion and that the spring is working properly. Ensure there are no frays or kinks in the rope and that the knot is tight and secure. Fully close and tighten each of the threaded chain links if they are open or loose. Ensure that each of the arms of Eleviia and each of the elastomers has no visible damage. If any parts have suffered damage, appropriately dispose of this set of Eleviia.

4) While using Eleviia, always keep your feet directly under your body to minimize the chance of injury in the event of door frame or equipment failure. Never hang on Eleviia upside down.

5) Use this equipment ONLY for the intended use as described by the manufacturer. DO NOT modify or disassemble the equipment or use attachments not recommended by the manufacturer. Do not paint Eleviia.

6) Do not untie the knot. If the knot becomes untied, contact Duonamic for a replacement rope.

7) Do not get Eleviia wet. It is not waterproof.

8) Perform pull ups smoothly. Do not perform fast or jerky movements while using Eleviia, and do not jump onto or off Eleviia. Do not perform kipping pull ups or one arm pull ups. Do not swing or off load your weight from Eleviia during use.

9) Consult your physician before starting an exercise program involving Eleviia or any other exercise program. Fitness training can result in serious injury or death. Risk of injury can be lessened when safe technique and common sense are practiced. Before beginning your first workout, become familiar with Duonamic Eleviia. Contact Duonamic at www.duonamic.com if you have any questions regarding the equipment. If you have any questions consult your physician. Your physician should assist you in determining the target heart rate zone appropriate for your age and physical condition. Certain exercise programs or types of equipment may not be appropriate for all people.

This is especially important for pregnant women, or those with preexisting health problems or wrist, elbow, shoulder or other joint and muscle impairments. If you are taking medication which may affect your heart rate, a physician's advice is absolutely essential before use of this equipment.

10) Warm up or/and stretch before performing any exercise program with Eleviia. Warm up or/and stretching could reduce chances for injury.

11) Do not overexert yourself while using Eleviia. Listen to your body and respond to any reactions you may be having. You must learn to distinguish "good" pain, like fatigue, from "bad" pain, which hurts. If you experience any pain or tightness in your chest, an irregular heartbeat, dizziness, nausea, or shortness of breath, stop exercising at once and consult your physician immediately.

12) THIS EQUIPMENT IS NOT FOR USE BY CHILDREN. To prevent injuries, keep this and all fitness equipment out of the reach of children. Follow these simple rules: – Keep children out of rooms where you have your exercise equipment. – Store exercise equipment in a room that can be locked. – Know exactly where your children are when you work out. – If you have small children at home, don't wear headphones while you work out. – Talk to your kids about the dangers of exercise equipment.

13) Breathe naturally, never holding your breath during an exercise. Avoid over-training. You should be able to carry on a conversation while exercising.

14) Cool down after an exercise session with 5 to 10 minutes of gentle aerobic exercise, such as walking, followed by stretching.

15) Handicapped or disabled people must have medical approval before using this equipment and should be under close supervision when using any exercise equipment.

16) Do not store Eleviia in direct sunlight or near direct heat sources.

17) Do not put hands, feet or any foreign objects on or near this equipment when in use by others. Use caution to not pinch fingers or hands in moving parts when setting up or using the equipment.

18) Duonamic Eleviia is designed and constructed for personal or household use only. Eleviia should not be used in commercial settings including, without limitation, health clubs and fitness centers. Further, use of Eleviia in a commercial setting or resale by an unauthorized dealer voids the warranty. See the Limited Warranty section for details.

19) When performing pullups, never pull up with the handles behind your head, as this places undue stress on shoulders and neck. Also, when performing pullups, avoid crossing feet, as this places your hips in an uneven position and impacts body alignment.

Disclaimer

Duonamic Technology Inc. shall not be liable for, nor shall you make any claim for any direct, indirect, incidental, special, consequential, punitive, or exemplary damages arising from the use of Duonamic Eleviia, including, but not limited to, damages for economic loss of profits or savings; lost wages; damages to or loss of use of property; bodily injury; medical payments; pain and suffering; and loss of consortium. In the event that applicable law does not allow the exclusion of warranties stated herein or the limitation of liability stated herein, then you expressly agree that in no event will the liability of Duonamic Technology Inc., for any claim or damages hereunder exceed the purchase price paid for Duonamic Eleviia.

Limited Warranty

Duonamic Technology Inc. warrants that this product will be free from defects in materials and workmanship under normal use, service and proper operation for a period of one year from the date of the original purchase from an authorized retailer. THIS WARRANTY SHALL NOT APPLY TO ANY PRODUCT WHICH HAS BEEN SUBJECT TO COMMERCIAL USE, ABUSE, MISUSE, ALTERATION OF ANY TYPE OR CAUSE OR TO ANY DEFECT OR DAMAGE CAUSED BY REPAIR, REPLACEMENT, SUBSTITUTION OR USE WITH PARTS OTHER THAN PARTS PROVIDED BY DUONAMIC TECHNOLOGY INC. Commercial use includes use of the product in athletic clubs, health clubs, spas, gymnasiums, exercise facilities, and other public or semipublic facilities whether or not the product's use is in furtherance of a profit making enterprise, and all other use which is not for personal, family, or household purposes. To implement this limited warranty, send a written notice stating your name, date, and place of purchase and a brief description of the defect along with your receipt to Duonamic Technology Inc. 333 9 Ave NE Calgary AB Canada T2E0V7, or email us at sales@duonamic.com, or contact us through the website www.duonamic.com. If the defect is covered under this limited warranty, you will be requested to return the product or part to us for free repair or replacement at our option. NO ACTION FOR BREACH OF THIS LIMITED WARRANTY MAY BE COMMENCED MORE THAN ONE (1) YEAR AFTER THE DATE THE ALLEGED BREACH WAS OR SHOULD HAVE BEEN DISCOVERED. NO ACTION FOR BREACH OF ANY IMPLIED WARRANTY MAY BE COMMENCED MORE THAN ONE (1) YEAR AFTER DELIVERY OF THE PRODUCT TO THE PURCHASER. This limited warranty is not transferable. IF ANY PART OF THE PRODUCT IS NOT IN COMPLIANCE WITH THIS LIMITED WARRANTY OR ANY IMPLIED WARRANTY, THE REMEDY OF REPAIR OR REPLACEMENT IS THE EXCLUSIVE REMEDY AVAILABLE TO YOU. In the event that the purchaser makes any claim under this limited warranty or any implied warranty, the Warrantor reserves the right to require the product to be returned for inspection, at the purchaser's expense, to the Warrantor's premises in Calgary, Canada. Return of the enclosed warranty registration card is not required for warranty coverage, but is merely a way of establishing the date and place of purchase. Duonamic Technology Inc. SHALL NOT BE LIABLE FOR THE LOSS OF USE OF ANY PRODUCT, LOSS OF TIME, INCONVENIENCE, COMMERCIAL LOSS OR ANY OTHER INDIRECT, CONSEQUENTIAL, SPECIAL OR INCIDENTAL DAMAGES DUE TO BREACH OF THE ABOVE WARRANTY OR ANY IMPLIED WARRANTY. This limited warranty is the only written or express warranty given by Duonamic Technology Inc. This warranty gives you specific legal rights, and you may also have other legal rights which vary from state to state. ANY OTHER RIGHT WHICH YOU MAY HAVE, INCLUDING ANY IMPLIED WARRANTY OR MERCHANTABILITY OR FITNESS FOR A PARTICULAR PURPOSE, IS LIMITED IN DURATION TO THE DURATION OF THIS WARRANTY. The laws in some jurisdictions restrict the rights of manufacturers and distributors of consumer goods to disclaim or limit implied warranties and consequential and incidental damages with respect thereto. If any such law is found to be applicable, the foregoing disclaimers and limitations of and on implied warranties and consequential and incidental damages with respect thereto shall be disregarded and shall be deemed not to have been made to the extent necessary to comply with such legal restriction.