



SARIS
INFRASTRUCTURE

BOTTLE FILL AND BIKE WASH STATIONS
INSTALLATION INSTRUCTIONS

Customer Service
800.783.7257
sarisinrastructure.com

Tell Us What You Think



sarisinrastructure.com

**Register your product for updates
sarisinrastructure.com/registration**



Thanks for buying our Bottle Fill and Bike Wash Station

Thank you for your purchase! Installing a Bike Wash Station or Bottle Fill Station creates an oasis for cyclists. Top off your water bottle or hydration bag, give your bike a rinse and get back on the trails looking and feeling good!

These cyclist-specific hydration and wash stations are designed to be plumbed-in like a traditional water fountain and have minimal space requirements. Please note that if installing near a Saris Infrastructure Work Stand, space requirements vary. The Wash Stations are equipped with the 4 most commonly used brushes for cleaning bicycle frames and drive trains to help keep your ride running smoothly.

Designed to work with standard municipal water pressure, the flow rate of the Bottle Fill and Wash Stations comes in at 2.0 gpm (@ 60 psi) or 7.6L/min. Both stations are rated for a temperature range of 32 – 110 F (0 – 43 C). If stations will be exposed to sub-freezing temperatures and operation must continue, stations should be installed with an after-market below-grade heating system. If water supply is discontinued through winter/cold seasons, it is recommended to clear the internal and external water lines with pressurized air. Installation also requires a sanitary drain or dry well hookup (check local codes). A ground water filtration system is not required as per the Environmental Protection Agency of the United States.

Please read and understand the following instructions before beginning your installation.

Everyone here at Saris Infrastructure want you to be happy with this product. Please contact us (sales@sarisinfrastructure.com, 800-783-7257) should you need anything.

Site Layout for Bottle Fill and Bike Wash Stations

Minimum Space Requirements

The minimum space requirements for the Bike Wash Station and Wash and Fill Station are dependent on whether there is a Wheel Chock, Public Work Stand, or Deluxe Public Work Stand installed. Match the equipment you will be installing with the figures below to determine minimum space requirement dimensions.

Setback Minimum and Site Layouts:

It is recommended that all equipment is spaced a minimum of 60" from an adjoining street or cycle path. The Saris Infrastructure Bottle Fill Station can be installed by itself. See figure 1. The minimum space requirements for the Saris Infrastructure Bike Wash Station is dependent on what bike holding fixture is used with it. See figures 2 through 9.

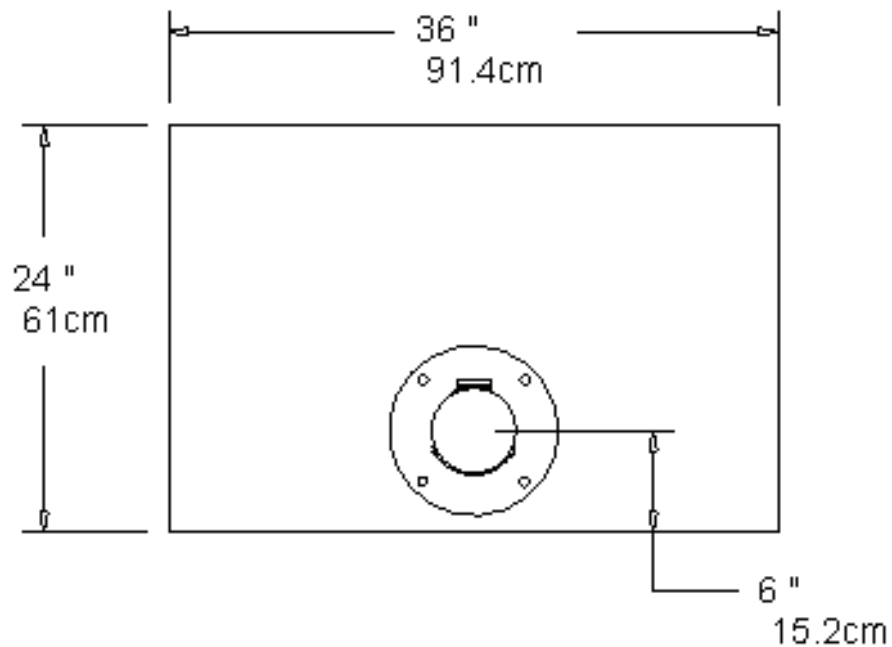

Figure 1: Minimum space requirements for Bottle Fill Station

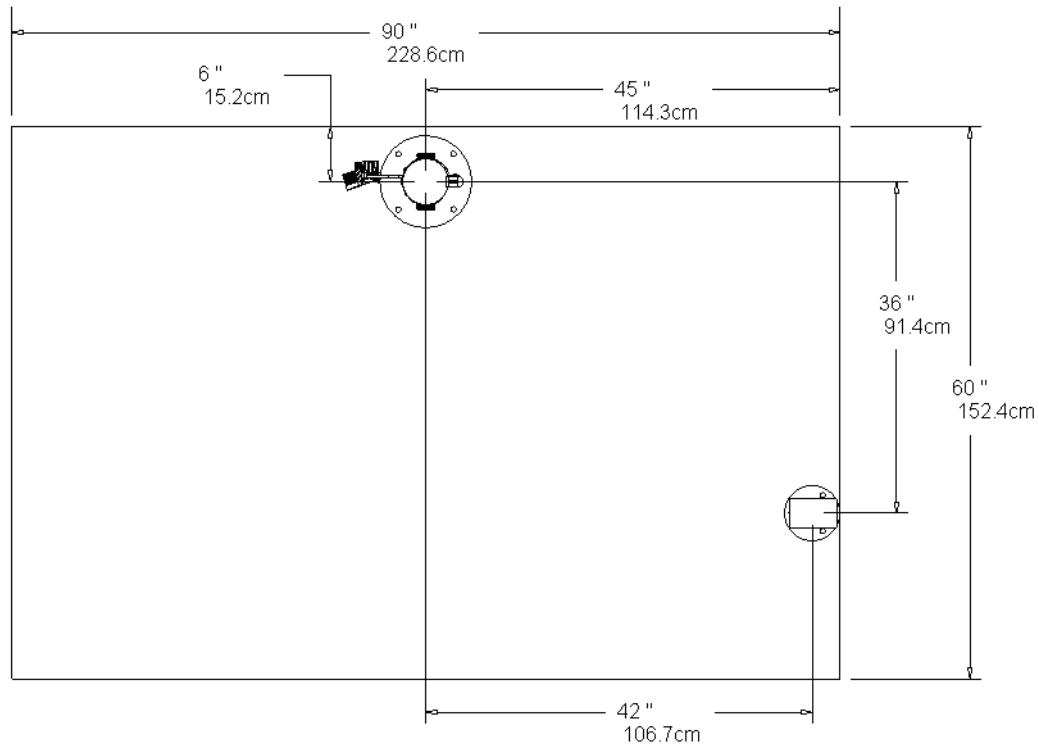

Figure 2: Minimum space requirements for Bike Wash Station (with Wheel Chock)

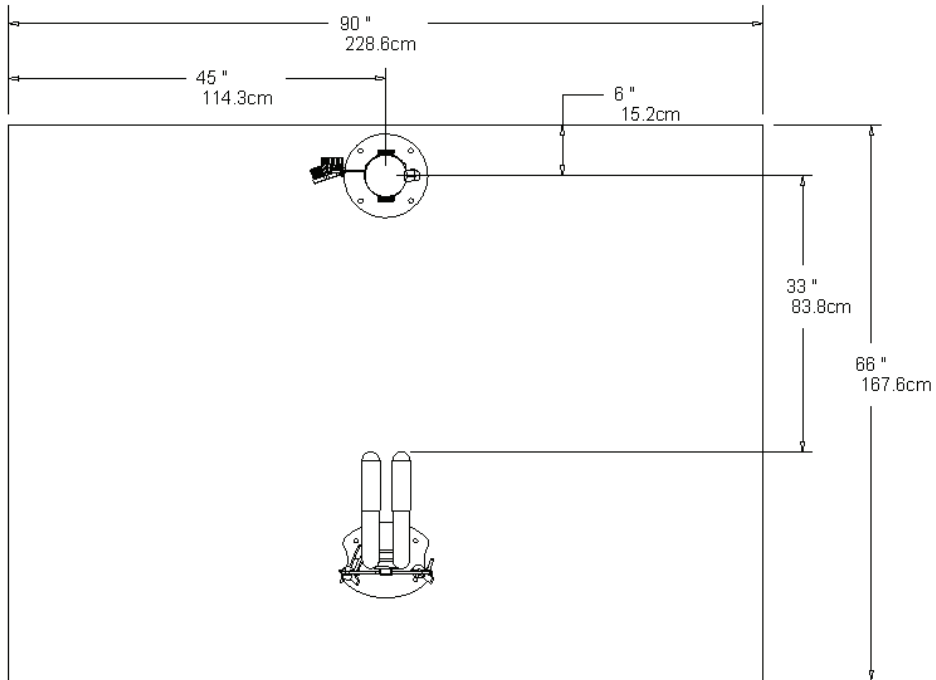

Figure 3: Minimum space requirements for Bike Wash Station (with Public Work Stand)

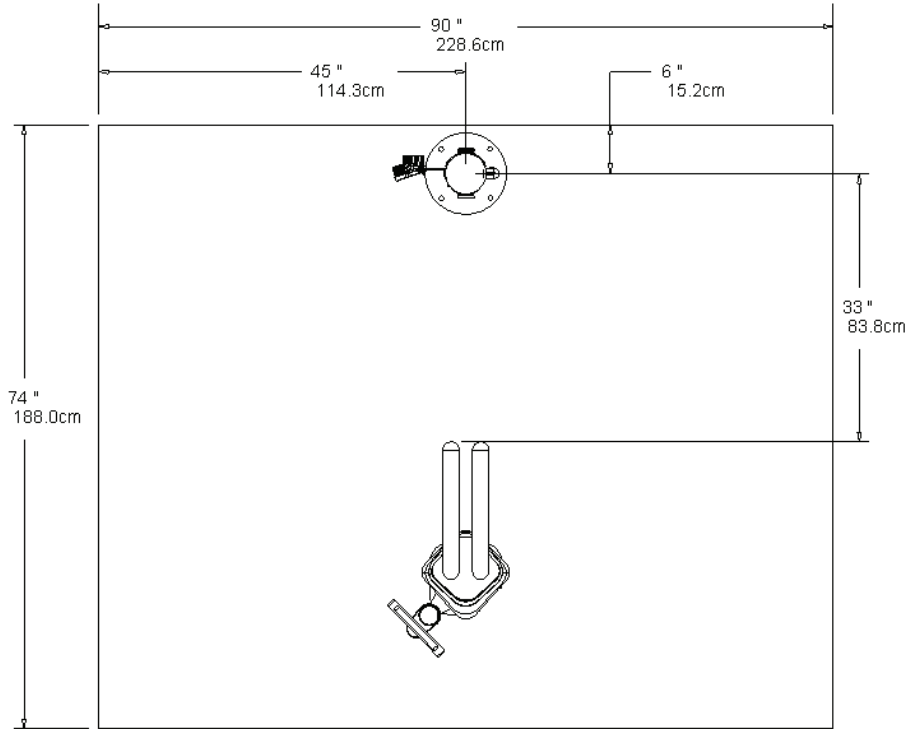

Figure 4: Minimum space requirements for Bike Wash Station (with Deluxe Public Work Stand, no Wheel Chock)

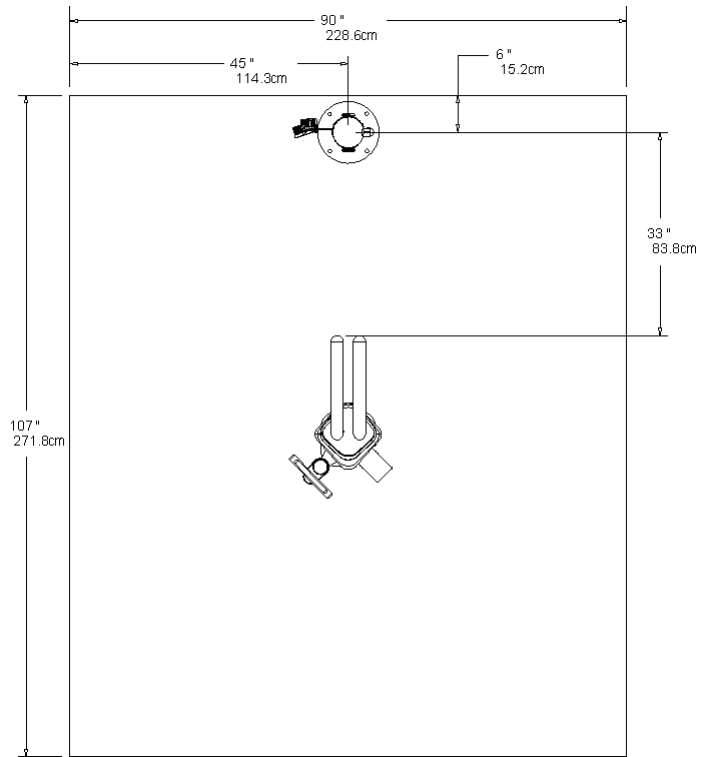

Figure 5: Minimum space requirements for Bike Wash Station (with Deluxe Public Work Stand, with Wheel Chock)

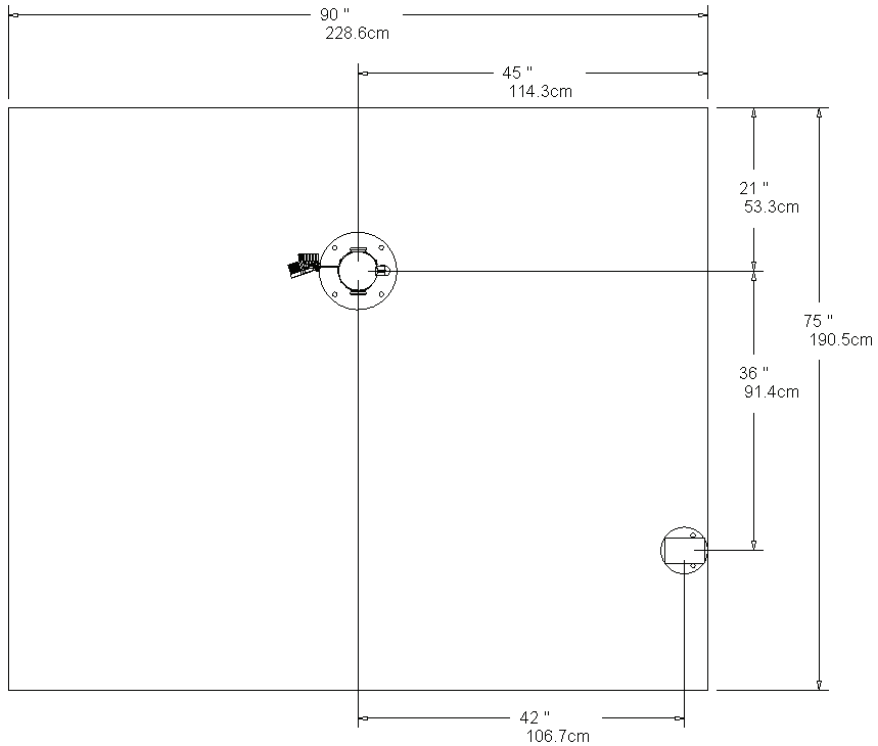

Figure 6: Minimum space requirements for Wash and Fill Station (with Wheel Chock)

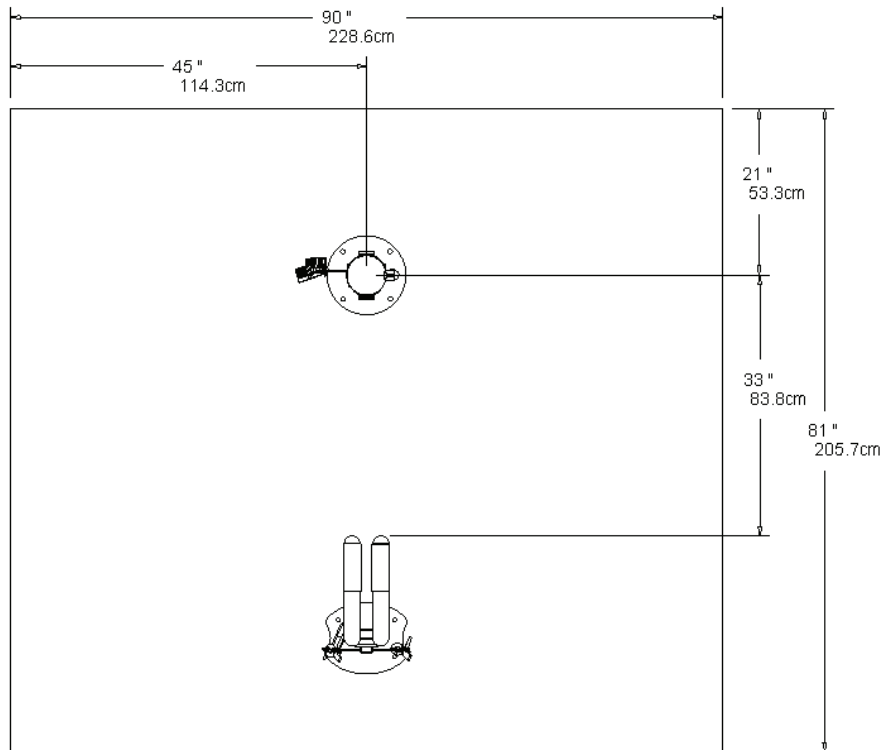

Figure 7: Minimum space requirements for Wash and Fill Station (with Public Work Stand)

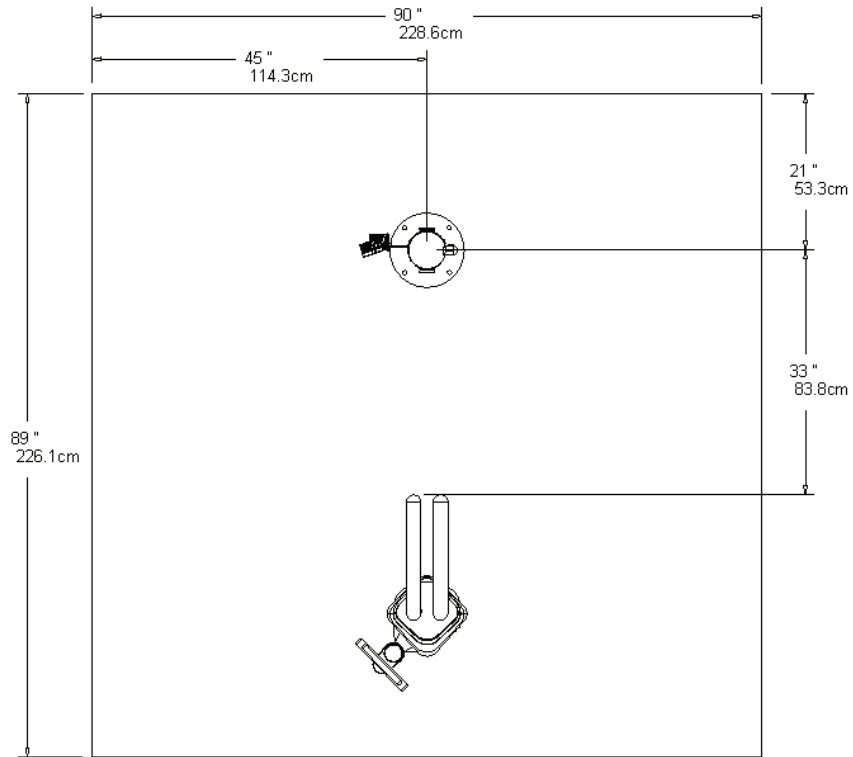

Figure 8: Minimum space requirements for Wash and Fill Station (with Deluxe Public Work Stand)

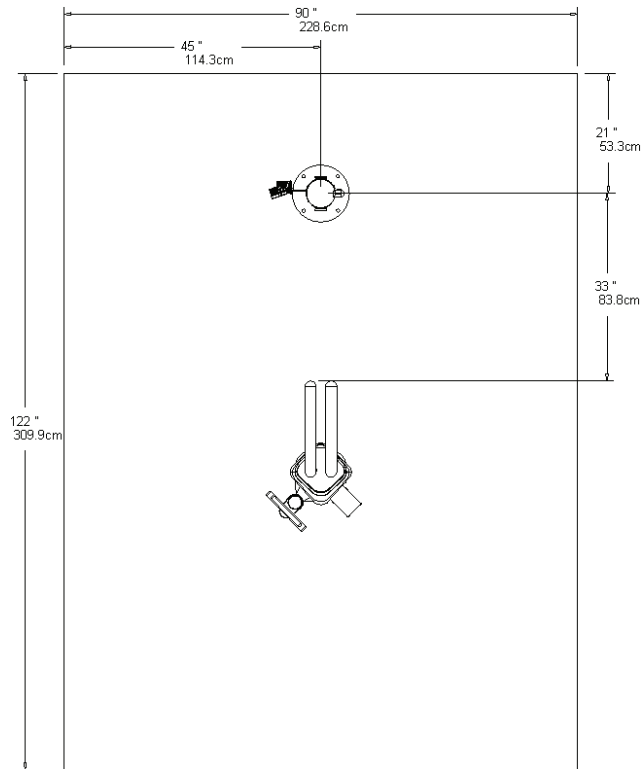

Figure 9: Minimum space requirements for Wash and Fill Station (with Deluxe Public Work Stand and Wheel Chock)

Concrete Pad Sizes

If you are pouring a new concrete pad, these are two recommended sizes. Option 1 is 36" x 36" x 4", option 2 is a 16" diameter cylinder that is 36" deep. Ensure there are provisions for the plumbing rough in.

Setbacks

It is recommended that all equipment is spaced a minimum of 60" from an adjoining street or cycle path.

Bike Wash and Bottle Fill Station Site Considerations

The Saris Infrastructure Bike Wash Station can be installed indoors or outdoors. The Saris Infrastructure Bike Wash Station is compliant with the EPA's Clean Water Act and does not require any post water treatment of wastewater. For indoor locations, a floor drain in the immediate area is recommended. Site should be suitable for water overspray. For outdoor locations, a subsurface drain (also known as a French drain) may be used if a municipal drain is not available on a permeable surface. Check local codes for drainage requirements.

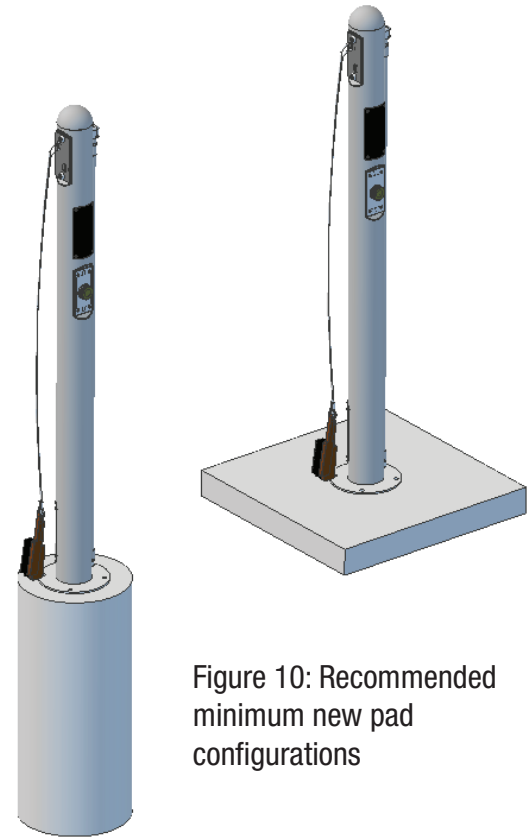

Figure 10: Recommended minimum new pad configurations

Plumbing Rough In

Inlet requirements:

Saris Infrastructure Wash Stations and Bottle Fill Stations for North America come equipped with a 3/8" NPTF inlet fitting connected to 3/8" supply tubing. For other regions, contact sales@sarisinrastructure.com for the proper connection.

Drain:

Saris Infrastructure Bottle Fill Stations come with an integrated 1-1/4" IPS drain. Saris Infrastructure Bike Wash Station does not require integral drain. Plumbing rough in to come up through the center of the fixture. See Figure 4 indicated rough in through hole in base flange.

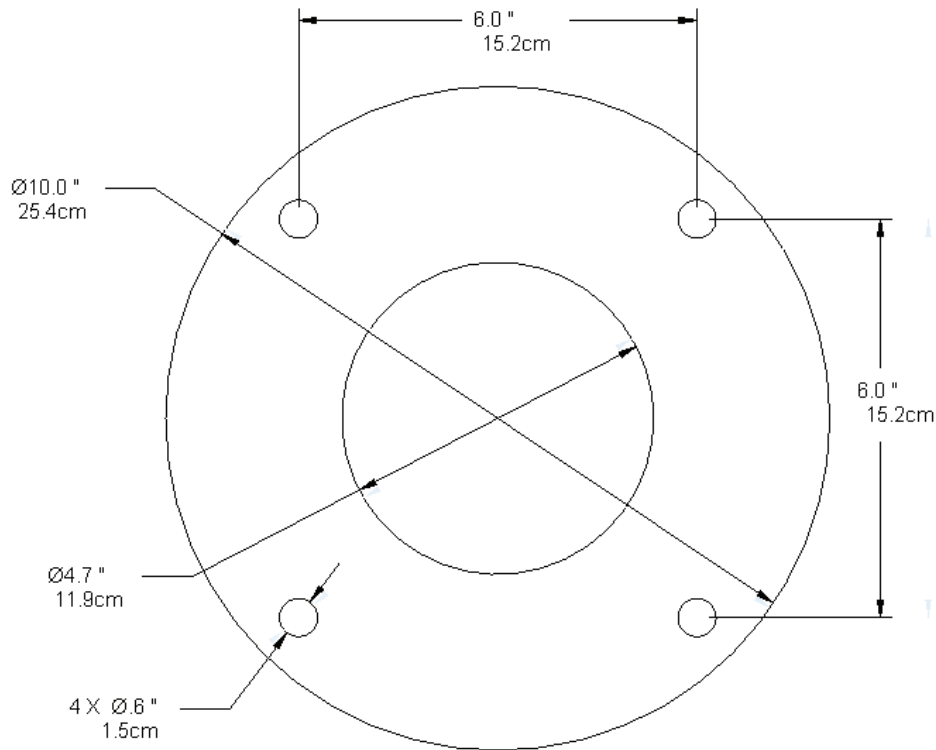

Figure 11: Base flange dimensions.

Cold Weather Operation

When water freezes, it expands by approximately 9%. This expansion will damage Saris Infrastructure Bike Wash and Bottle Fill stations by rupturing the plumbing lines if used below freezing. To avoid this, we recommend winterizing your installation by blowing the plumbing supply lines out with compressed air and capping the water lines. You do not need to remove the equipment. For more information, contact sales@sarisinfrastructure.com.

Installation

Tools Needed for Installation (Installer Provides)

Tape measure

½” masonry drill bit drill (hammer drill recommended)

Hammer

3/8” drive ratchet and extension

Marker or pencil

SAE hex key set

Level

Tools for Installation Provided with Equipment



Anchor Set Tool *Penta-Plus Bit *Penta Security Socket 4 Concrete Anchors

2 button head hex bolts
2 threaded concrete anchor studs
2 Penta nuts (use with anchor studs)

***DO NOT THROW AWAY THE PENTA SOCKET OR PENTA-PLUS BIT AFTER COMPLETING THE INSTALLATION. YOU WILL NEED IT TO REMOVE OR MAINTAIN THE EQUIPMENT IF THAT IS NECESSARY.**

1. Refer to site layout instructions in from this manual.
2. Install shut-off valve on water supply. (Valve not furnished)
3. Place the fixture in the desired location (see site layouts). Use a marker or pencil to outline the holes of the flange onto the base material. We recommend checking the hole locations after each new anchor is placed. Ensure the holes are at least 6" away from any cracks in the base material. Ensure proper clearance of plumbing connections through the center of the fixture.
4. The concrete anchor (a.k.a "drop in anchor") is a female anchor designed for use in solid concrete only and cannot be used in brick or block base material. The anchor size is designated by the inside diameter of the anchor. The Saris Infrastructure Bike Wash and Bottle Fill Stations come with 3/8"-16 anchors. The diameter of the hole to be drilled is the same size as the outside diameter of the anchor which is 1/2".
5. When fastening to solid concrete with a drop in anchor, a hole must first be drilled into the concrete. A hammer drill should be used as it will drill the best quality hole. Once the bit is inserted into the hammer drill, the depth of the hole to be drilled can easily be set by using the depth gauge on the drill or by wrapping the bit with tape at the required depth. We recommend a drill depth of 1-5/8" deep so that the anchor just sets down flush with the surface.

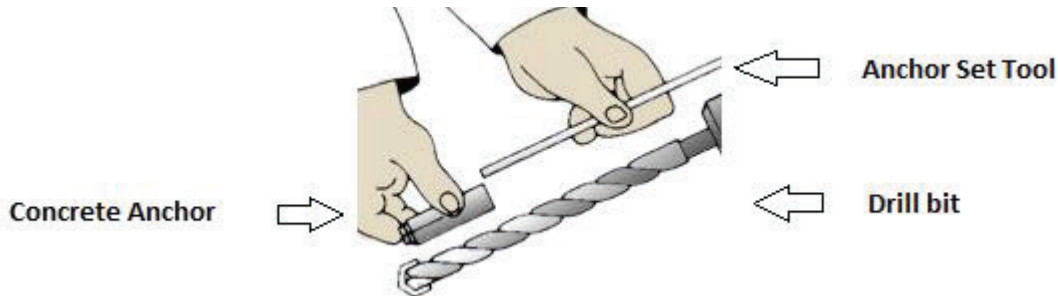

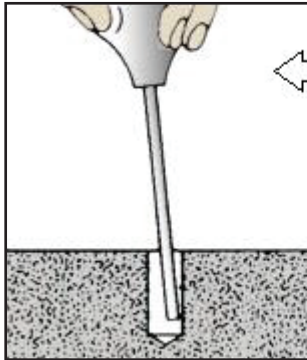
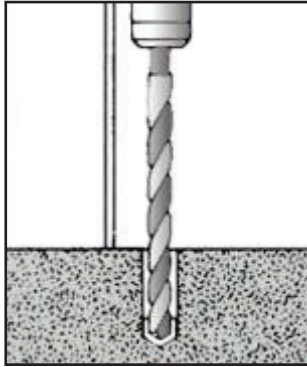

Tool to remove debris
after drilling holes.
Installer provides.

6. Before starting to drill the hole, it is important that eye and ear protection are used. Make sure the hammer drill is in the hammer mode and start drilling your hole. Continue drilling until the tape on the bit or the drill gauge meets the base material; this means that the required depth has been reached.
7. Before proceeding with installation, the hole must be cleaned of all concrete dust to ensure proper fastening. Use a wire brush, a vacuum or compressed air to clean out the hole completely.
8. Insert the drop in anchor with the open side up. Tap lightly to get the anchor flush with the base material.

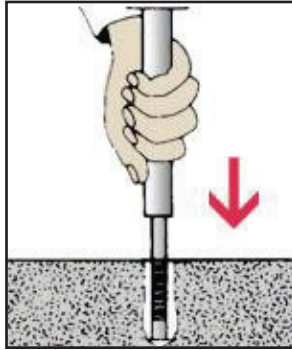

9. Take the setting tool and insert it into the anchor. Strike the setting tool with the hammer until the lip of the anchor touches the lip of the setting tool. This will ensure the anchor is properly set.
10. Place the fixture over the four anchors. Thread two anchor studs into anchors on opposite sides of flange. Thread two Penta nuts onto studs. Do not tighten. Thread two hex nuts into other anchors. Do not tighten.
11. Level base flange. Place washers underneath flange as needed. Tighten Penta Nuts with Penta Socket. Tighten hex nuts with hex key.
12. Remove access panel by removing four penta-plus screws using supplied penta-plus bit.
13. Connect water supply and Bottle Fill Station/Wash and Fill Station drain. Water connection and drain must comply with local codes. Connecting lines should be thoroughly flushed to remove all foreign matter before being connected to fixture.
14. Turn on water supply and check all connections for leaks.

CAUTION: THIS FOUNTAIN IS RATED FOR INLET WATER PRESSURE OF 20-80 PSI. A PRESSURE REDUCING REGULATOR SHOULD BE USED IF THE INLET WATER SUPPLY EXCEEDS 80 PSI. ANY DAMAGE CAUSED BY REASON OF CONNECTING THIS PRODUCT TO SUPPLY LINE PRESSURES LOWER THAN 20 PSI OR HIGHER THAN 80 PSI IS NOT COVERED BY WARRANTY.

15. For Bottle Fill and Wash and Fill Stations, test water fill pressure to ensure smooth laminar flow. If supply pressure is too high, remove push button valve plate using the included penta-plus bit. Adjust ball valve until desired flow is achieved. See section 3 for details.
16. Contractor to supply waste trap and service stop valve in accordance with local code.
17. Reinstall access panel using the included penta-plus bit.
18. For Bike Wash Stations, remove brush plates, place cable stops through the slots and reattach plates using included penta-plus screws.
19. Congrats, you've completed installation!

WARNING: Manufacturer and seller expressly disclaim any and all liability for personal injury, property damage or loss, whether direct, indirect, or incidental, resulting from the incorrect attachment or inappropriate placement, improper use, inadequate maintenance, or neglect of this product. Placement of this product is beyond control of the manufacturer. It is the end users reasonability to place this product so as to avoid potential pedestrian or playground accidents.

WARRANTY: We warrant this product to the first consumer to be free from defect in material and workmanship for a period of one year from date of purchase. Please retain your sales slip for your records. Any product or part thereof found to be defective within that period will be replaced without charge provided that: (1) the product was not misused; (2) no alterations or modifications were made; (3) its failure resulted from a defect in material or workmanship and not from normal wear expected in the use of the product; (4) the product or part is delivered, freight prepaid, to Saris Products.

Manufacturer's only obligation shall be to replace such products or parts proved to be defective.

Saris Cycling Group 5253 Verona Road Madison, WI 53711 (800) 783-7257 www.sarisinfrastructure.com