



**SARIS**  
INFRASTRUCTURE

**OUTDOOR PARKING SYSTEM** INSTALLATION

Customer Service  
800.783.7257  
[sarisinfrastucture.com](http://sarisinfrastucture.com)

**Tell Us What You Think**



**[sarisinfrastructure.com/feedback](https://sarisinfrastructure.com/feedback)**

**Register your product for updates**  
**[sarisinfrastructure.com/registration](https://sarisinfrastructure.com/registration)**



## Thanks for purchasing a Saris Infrastructure product!

The rack you are about to install was USA born and bred. The steel came from a foundry in the Midwest and was delivered to our manufacturing facility in Madison, WI. Under our watchful eye it was bent and welded. After having a finish applied locally, it has made its way to you.

Bicycle racks are amazing pieces of infrastructure. A simple bent piece of steel can unlock the incredible tool the bike can become. A secure parking rack makes communities and businesses healthier and happier. They eliminate one of the major obstacles for people not choosing to travel by bike: secure bike parking at their destination. So put a smile on your face as you place this rack into position because you are making the world a better place.

Please read and understand the following instructions before beginning your installation.

Everyone here at Saris wants you to be happy with this product. Please contact us ([sales@sarisinfrastructure.com](mailto:sales@sarisinfrastructure.com), 800-783-7257) should you need anything.

# Table of Contents

I.	Below Grade Mount	Page 2
II.	Flange Mount	Page 3
	A. Temporary and Temporary Secure Hardware Installation	Page 4
	B. Permanent Installation	Page 6
III.	Corral Mount	Page 7
	Corral Assembly	Page 7
	Corral Installation	Page 8
	A. Temporary and Temporary Secure Hardware Installation	Page 9
	B. Permanent Installation	Page 9
	C. Cement Anchor Installation	Page 11
	D. Earth Anchor Installation	Page 11
	E. Asphalt Anchor Installation	Page 12
IV.	Baseplate Mount	Page 13
	Baseplate Assembly	Page 13
	Baseplate Installation	Page 16

## I. Below Grade Mount

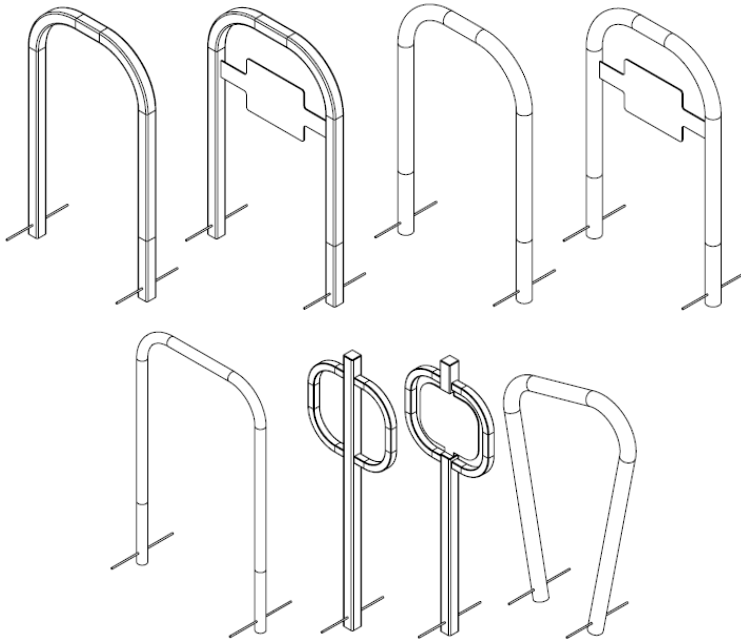

1. Determine desired location and dig mounting holes 17" below grade.
2. Fill hole 1/3 full with gravel.
3. Lower unit into holes and fill remainder of hole with cement. Verify the height of the rack to grade is correct.
4. Support unit with spacers, such as cinder blocks, until cement sets.

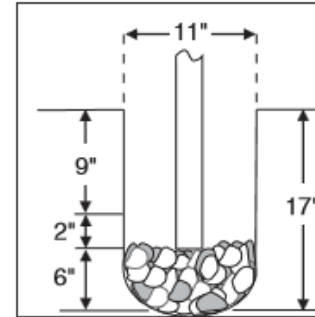

## II. Flange Mount

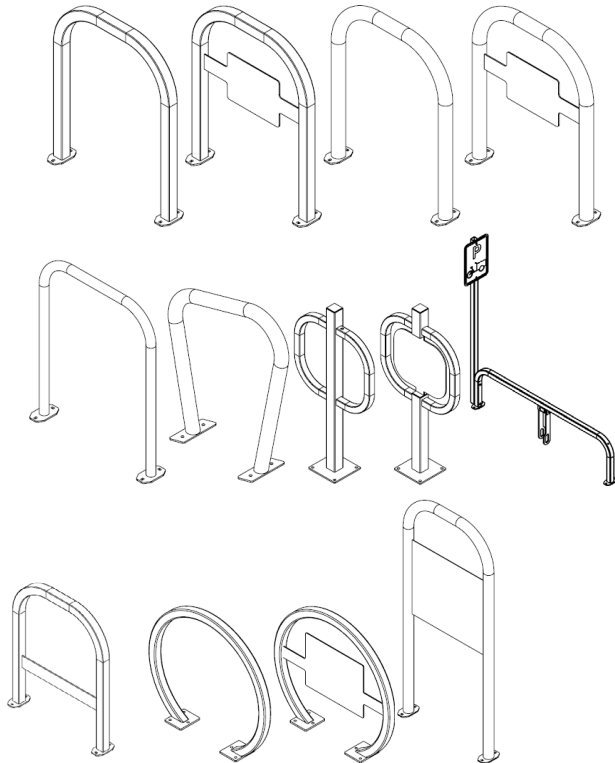

### A. Temporary Mount (P/N 28879) & Temporary Secure Mount (P/N 26270)-Sold Separately

### Circle dock Temporary Mount (P/N 29163) & Temporary Secure Mount (P/N 29164)-sold separately

### Tools Needed for Installation (Sold by Saris)

- Anchor Set Tool P/N 25683



- Penta Security Socket P/N 27126  
(only needed for temporary secure installation)



### Tools Needed for Installation (Installer Provides)

- Tape Measure
- ½" Masonry Drill Bit Drill (Hammer drill recommended)
- Hammer
- 3/8" drive ratchet
- Marker or Pencil
- 7/32" hex key
- Level

**\*DO NOT THROW AWAY THE PENTA SOCKET AFTER COMPLETING THE INSTALLATION. YOU WILL NEED IT TO REMOVE THE EQUIPMENT IF THAT IS NECESSARY.**

1. Place the rack in the desired location (see setbacks document). Use a marker or pencil to outline the holes of the flange onto the base material. We recommend checking the hole locations after each new anchor is placed. Ensure the holes are at least 6” away from any cracks in the base material.
2. The concrete anchor (a.k.a “drop in anchor”) is a female anchor designed for use in solid concrete only and cannot be used in brick or block base material. The anchor size is designated by the inside diameter of the anchor. The diameter of the hole to be drilled is the same size as the outside diameter of the anchor which is  $\frac{1}{2}$ ”.
3. When fastening to solid concrete with a drop in anchor, a hole must first be drilled into the concrete. A hammer drill should be used as it will drill the best quality hole. Once the bit is inserted into the hammer drill, the depth of the hole to be drilled can easily be set by using the depth gauge on the drill or by wrapping the bit with tape at the required depth. We recommend a drill depth of 1-5/8” deep so that the anchor just sets down flush with the surface.

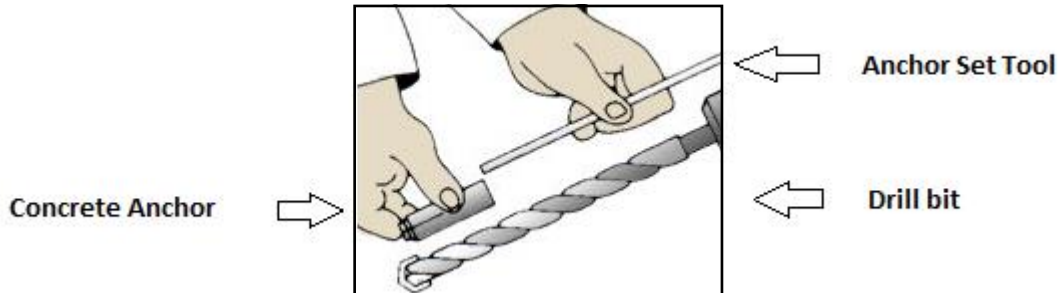

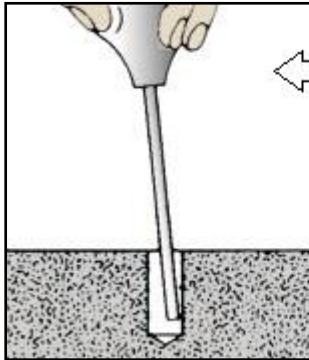
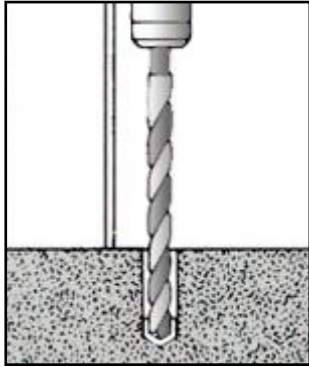

Tool to remove debris after drilling holes. Installer provides.

4. Before starting to drill the hole, it is important that eye and ear protection are used. Make sure the hammer drill is in the hammer mode and start drilling your hole. Continue drilling until the tape on the bit or the drill gauge meets the base material- this means that the required depth has been reached.
5. Before proceeding with installation, the hole must be cleaned of all concrete dust to ensure proper fastening. Use a wire brush, a vacuum or compressed air to clean out the hole completely.



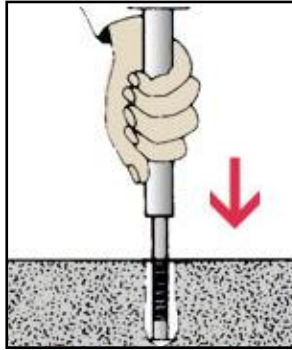

***Temporary mount hardware***

6. Next, insert the drop in anchor with the open side up. Tap lightly to get the anchor flush with the base material.
7. Now, take the setting tool and insert it into the anchor. Strike the setting tool with the hammer several times until the set no longer moves down. This will ensure the anchor is properly set.
  
8. Place the rack over the anchors. For temporary installation, you will be using 4 button head hex bolts. Use the 7/32" hex wrench to tighten the button head hex bolts.

For temporary secure installation, you will be using 2 studs w/ 2 Penta nuts and 2 button head hex bolts. Be sure to alternate between Penta nuts and button head bolts. You will thread the stud into the anchor prior to installing the Penta nuts using the Penta socket. Use the 7/32" hex wrench to tighten the button head hex bolts.



*Temporary secure mount hardware*



9. Before tightening everything down, make sure the rack is level and adjust accordingly with washers underneath the flanges

### **B. Permanent Mount (Model #6266 - Sold Separately)**

1. Determine desired location of unit.
2. Using a 3/8" masonry drill bit, drill through the flange mount and into the concrete 4-1/4".
3. Blow the hole clean of dust and other material.
4. Drive spike through flange mount and into hole, until head of spike is seated on the flange mount.

### III. Corral Mount

#### Corral Assembly

1. Level Prop rails up on blocks of wood to provide ample clearance for a socket wrench underneath.
2. Line up docks onto rails so that the flange holes line up with the rail holes. Note: Rails are designed with 2 mounting configurations (Angled and Straight). Be sure to line the holes up accordingly.

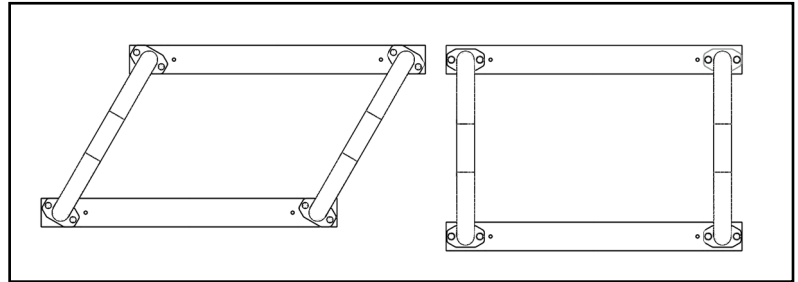
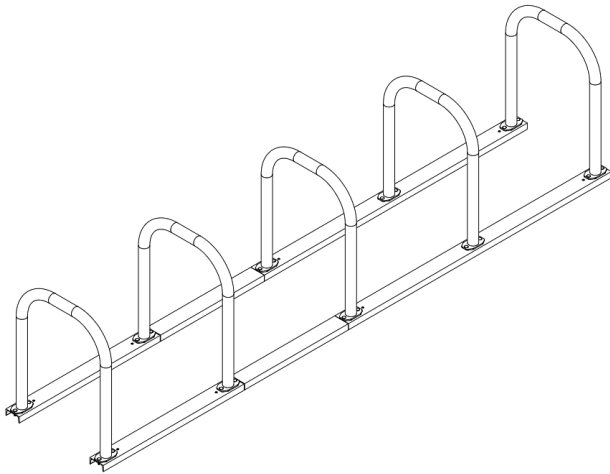

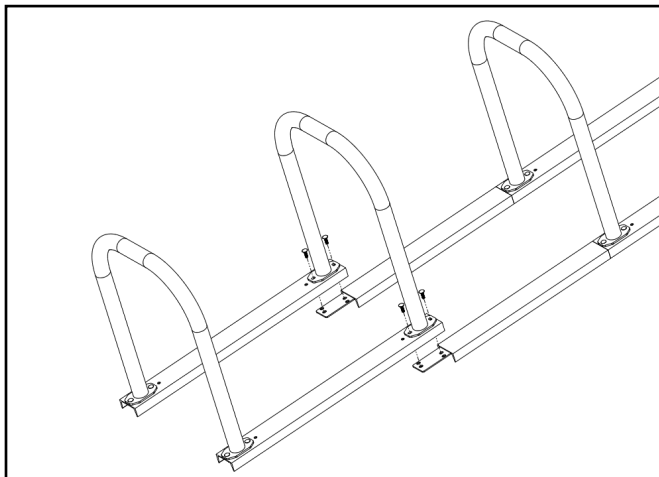
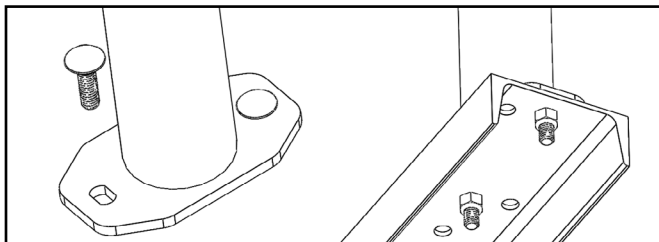

3. Place carriage bolts through the dock flanges and tighten the nut underneath finger tight.
4. If you are assembling a 10 or 12 bike corral, you will need to connect the rails with the corral joiner. The carriage bolts for these locations will pass through the dock flange, the rail, and the joiner tab.
5. When all docks are assembled onto the rails, verify they are aligned and parallel.
6. Go back and tighten the nuts using a 9/16" socket.
7. It is not required to anchor the corral. However, there are anchoring holes at all 4 corners of the corral to allow anchoring to a variety of surfaces. Proceed to the next section of the manual for the various anchoring methods.

## Corral Installation

### A. Permanent Mount Installation (Model #6259 - Sold Separately)

1. Determine desired location of unit.
2. Using a 3/8" masonry drill bit, drill through the rail and into the concrete 6-1/4".
3. Blow the hole clean of dust and other material.
4. Drive spike through the rail and into hole, until head of spike is seated on the flange mount.



### B. Temporary Mount (P/N 29173) & Temporary Secure Mount (P/N 29172) Installation - Sold Separately

#### Tools Needed for Installation (Sold by Saris)

- Anchor Set Tool P/N 25683



- Penta Security Socket P/N 27126  
(only needed for temporary secure installation)



#### Tools Needed for Installation (Installer Provides)

- Tape Measure
- 1/2" Masonry Drill Bit Drill  
(Hammer drill recommended)
- Hammer
- 3/8" drive ratchet
- Marker or Pencil
- 7/32" hex key
- Level

**\*DO NOT THROW AWAY THE PENTA SOCKET AFTER COMPLETING THE INSTALLATION. YOU WILL NEED IT TO REMOVE THE EQUIPMENT IF THAT IS NECESSARY.**

1. Place the rack in the desired location (see setbacks document). Use a marker or pencil to outline the holes of the flange onto the base material. We recommend checking the hole locations after each new anchor is placed. Ensure the holes are at least 6” away from any cracks in the base material.
2. The concrete anchor (a.k.a “drop in anchor”) is a female anchor designed for use in solid concrete only and cannot be used in brick or block base material. The anchor size is designated by the inside diameter of the anchor. The diameter of the hole to be drilled is the same size as the outside diameter of the anchor which is ½”.
3. When fastening to solid concrete with a drop in anchor, a hole must first be drilled into the concrete. A hammer drill should be used as it will drill the best quality hole. Once the bit is inserted into the hammer drill, the depth of the hole to be drilled can easily be set by using the depth gauge on the drill or by wrapping the bit with tape at the required depth. We recommend a drill depth of 1-5/8” deep so that the anchor just sets down flush with the surface.

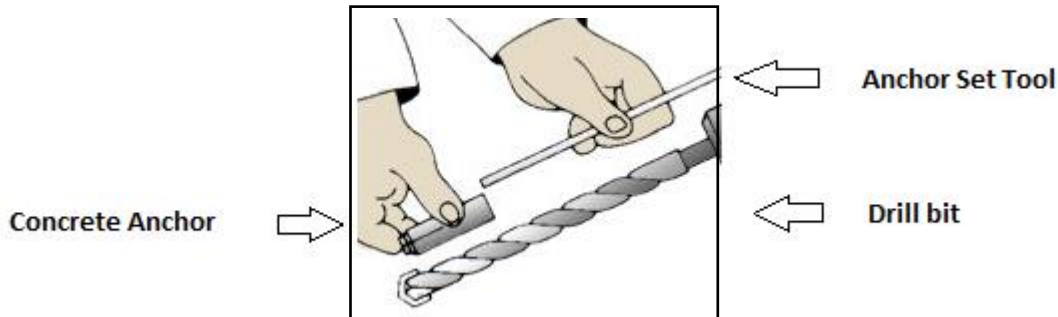

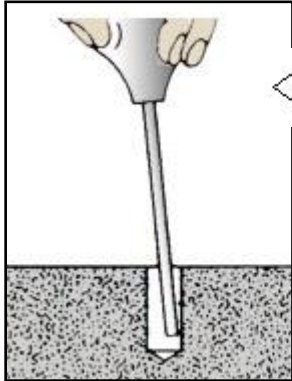
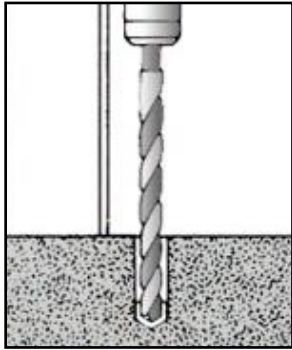

Tool to remove debris  
after drilling holes.  
Installer provides.

4. Before starting to drill the hole, it is important that eye and ear protection are used. Make sure the hammer drill is in the hammer mode and start drilling your hole. Continue drilling until the tape on the bit or the drill gauge meets the base material- this means that the required depth has been reached.
5. Before proceeding with installation, the hole must be cleaned of all concrete dust to ensure proper fastening. Use a wire brush, a vacuum or compressed air to clean out the hole completely.

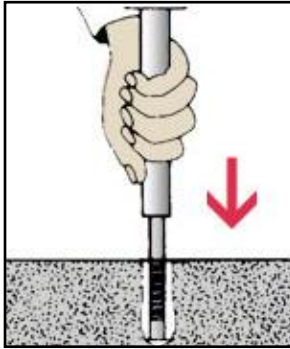

***Temporary mount hardware***

6. Next, insert the drop in anchor with the open side up. Tap lightly to get the anchor flush with the base material.
7. Now, take the setting tool and insert it into the anchor. Strike the setting tool with the hammer several times until the set tool no longer moves down. This will ensure the anchor is properly set.
8. Place the rack over the anchors. For temporary installation, you will be using 4 button head hex bolts. Use the 7/32" hex wrench to tighten the button head hex bolts.

For temporary secure installation, you will be using 2 studs w/ 2 Penta nuts and 2 button head hex bolts. Be sure to alternate between Penta nuts and button head bolts. You will thread the stud into the anchor prior to installing the Penta nuts using the Penta socket. Use the 7/32" hex wrench to tighten the button head hex bolts.





*Temporary secure mount hardware*

9. Before tightening everything down, make sure the rack is level and adjust accordingly with washers underneath the flanges.

### C. Cement Anchor Installation (P/N 6257) (Qty. 4 required)-Sold Separately

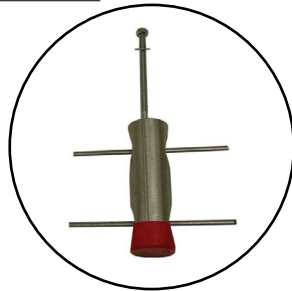
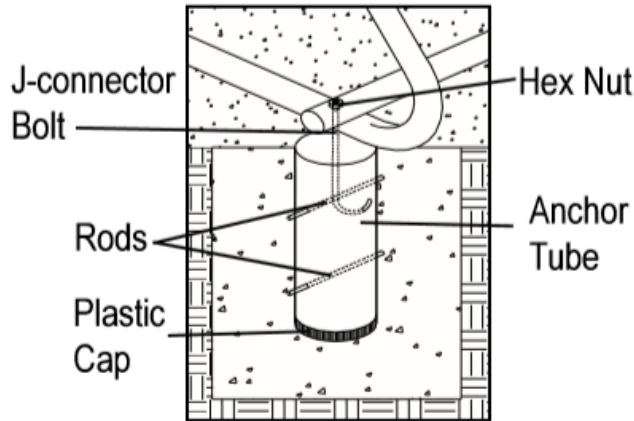

1. Push rods into the holes in the anchor tube so that they are protruding equally from each side.
2. Place plastic cap onto end of anchor tube to keep fresh cement or asphalt from entering through the bottom.
3. Determine location of each anchor tube (at the corners of the parking system). Dig hole or remove existing cement as necessary.
4. Set tube with cap facing downward, so that top of anchor is flush with surface of cement or asphalt.
5. Pour cement or asphalt around anchor, being careful not to allow tube to move.
6. After material has set, hook connector bolt under top rod and insert into hole of parking system. Secure with hex nut - do not overtighten. Cut off excess of J-connector bolt and peen top of bolt with hammer to deter removal of hex nuts.

## D. Earth Anchor Installation (P/N 6258) (Qty. 4 required)-Sold Separately

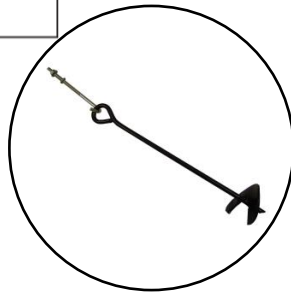
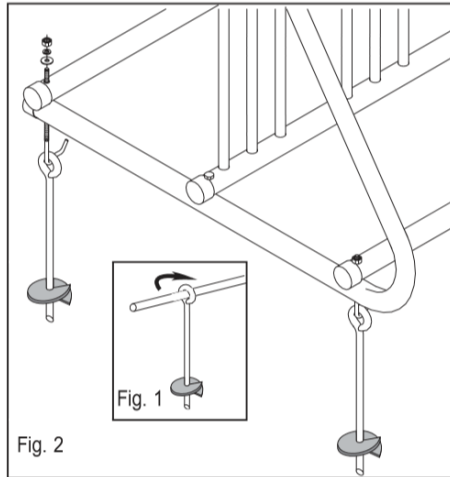

1. Using holes in unit (parking rack, picnic table, etc.) as a guide, mark mounting hole locations. Note: It may be necessary to drill holes in base of unit being secured.
2. Dig a 3-1/2" diameter starter hole approximately 3" below grade at each located mark.
3. With a bar or pipe inserted into anchor eye, screw anchor into soil until bottom of eye is flush with ground (Fig.1)
4. Hook J-bolt through anchor eye. Insert end of bolt up through hole in rack, table, etc. and secure with a 5/16" flat washer, split lock washer, and 5/16"-18 hex nut (Fig. 2). Cut off any excess bolt and pen with a hammer to deter removal.

## E. Asphalt Anchor Installation (P/N 6267) (Qty. 4 required)-Sold Separately



### Supplied:

- Cement Grout (3.5oz per anchor)
- Bolts 2.25" long, one per anchor
- T45 Security Torx Bit

### Required:

- 4 separate plastic bags for mixing and dispensing grout
- 2" bolt (hex head) for protecting anchor threads from debris
- Water
- Masonry drill bit, 7/8" x 6" (19mm)
- Tools: Hammer – drill; hammer; wrench for bolts

The instructions assume the use of a cement grout.

1. Drill a 7/8" hole perpendicular to the ground, to a depth 6".
2. Clean the hole and the area around it.
3. The threads of the anchor must remain clear of grout.
4. Separate cement grout powder into 4 separate bags. Mix each individual bag with approx. 1 oz of water. The grout should be a slurry consistency. The grout will harden within 15 minutes, so only mix the amount of grout you are ready to pour.
5. Apply the grout to the hole, filling it to the top. Allow the grout to flow; refill if necessary. Use a Ziploc bag as a dispenser (cut off a corner).
6. Using a hammer, gently drive the anchor into the ground until the top of the anchor is flush with the ground.
7. As you lower the anchor, make sure that the grout is visible all the way to the top. Add grout if required.
8. Once the anchor is in place, wash the surface of the roadway to remove the excess grout. Once the grout hardens, it will be practically impossible to remove the excess grout.
9. Allow the grout to harden for about 20 minutes.
10. Mount the device and secure with washers and bolts/nuts to the anchors.

**DO NOT SUBJECT THE INSTALLATION TO FULL LOAD FOR 2 HOURS, to allow the grout to cure.**

## IV. Base Plate Mount

### Baseplate Assembly

1. The Baseplate mount system is designed to mount a combination of Bike docks, post and ring racks, hoop signs, Deluxe Public Work Stands, and Manual Public Bike Pumps. Each baseplate can mount 2 fixtures each. Multiple baseplates can be connected with bolts using a joiner in between. End caps are meant to be placed on the outside of the end baseplates. It is recommended that 2 people perform the installation. Begin installation by laying out all the components for your installation.

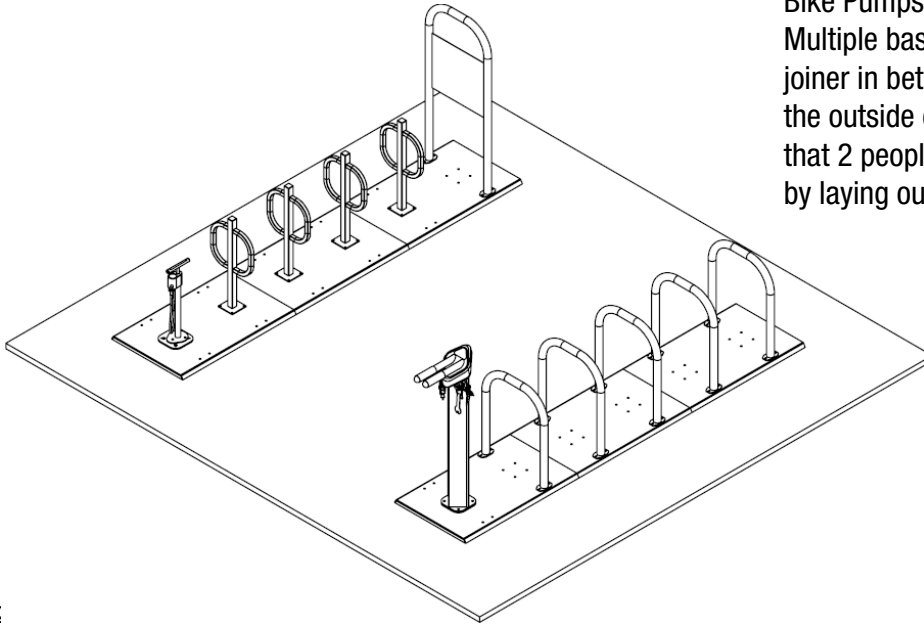

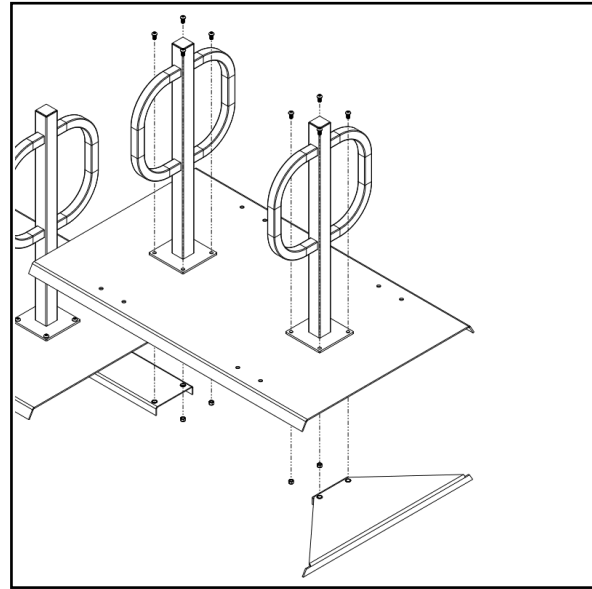
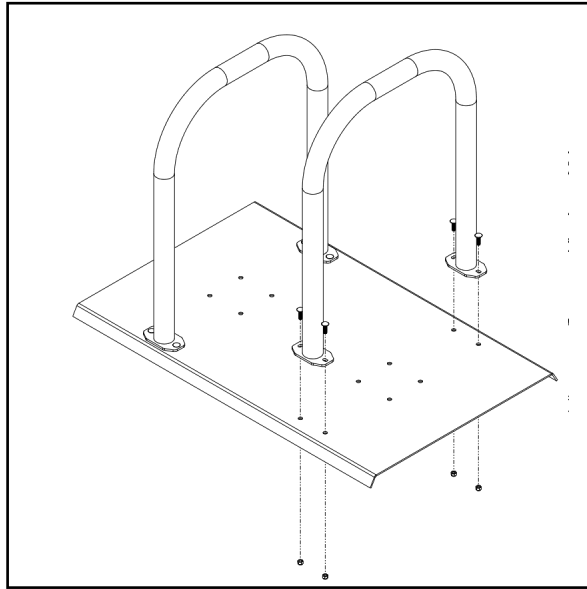

2. Begin installation with one baseplate. Attach docks and hoop signs using the outer most holes. Carriage bolts go through the dock or hoop sign flanges and through the baseplate. Tighten nuts from the bottom side. Attach post and ring racks using button head bolts from the top side. 2 of the 4 post and ring bolts are shared with the end caps and joiner. The button heads in these locations will tighten directly into the end cap or joiner. The other 2 locations will require nuts on the bottom side.

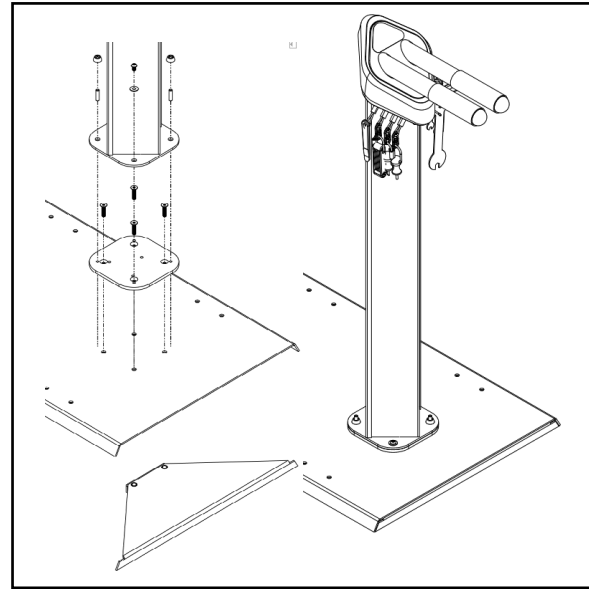
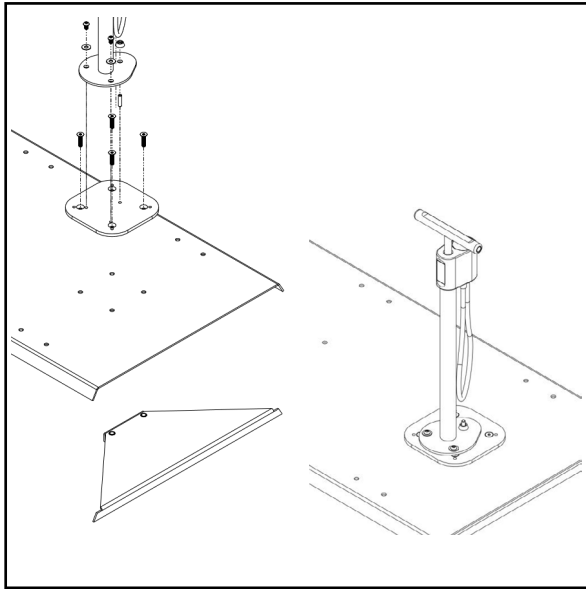

3. If you are installing a repair stand or pump, we recommend placing it at the end of the baseplate system. You will need to first install the repair station adapter plate at the center 4 holes using flat head fasteners. 2 of the 4 adapter bolts are shared with the end caps and joiner. The flat head fasteners in these locations will tighten directly into the end cap or joiner. The other 2 locations will require nuts on the bottom side. The pump or repair stand can then bolt directly to the adapter plate using the installation hardware that comes with the pump or repair stand.



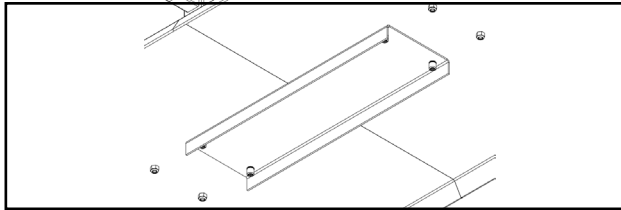
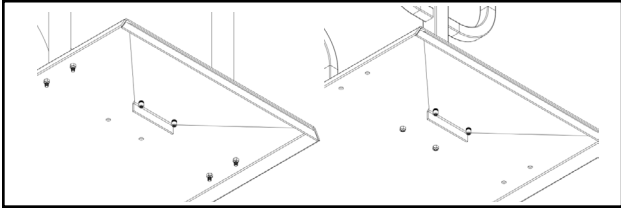

### Baseplate Anchoring

The baseplate is not intended to be anchored to the ground. Due to its weight, it is very difficult to move it as an assembly.

4. Assemble end cap on first baseplate before setting it down.
5. Connect additional baseplates using a joiner at each joint.
6. When all baseplates are connected, connect the last end cap and tighten fasteners.

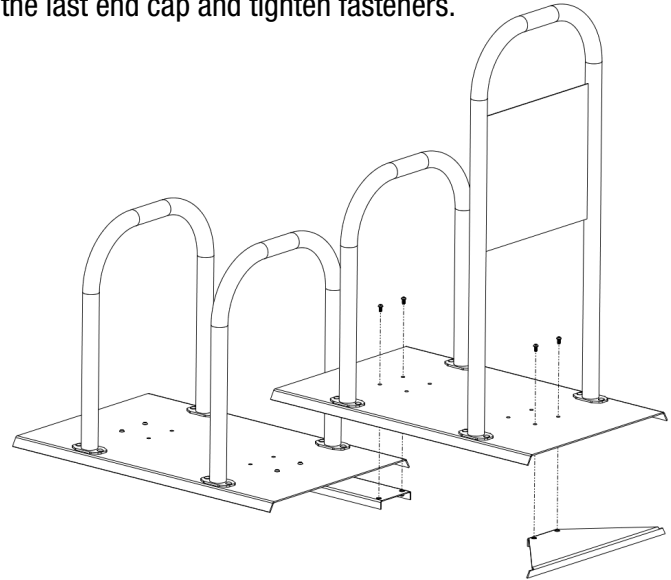

**WARNING:** Manufacturer and seller expressly disclaim any and all liability for personal injury, property damage or loss, whether direct, indirect, or incidental, resulting from the incorrect attachment or inappropriate placement, improper use, inadequate maintenance, or neglect of this product. Placement of this product is beyond control of the manufacturer. It is the end users reasonability to place this product so as to avoid potential pedestrian or playground accidents.

**WARRANTY:** We warrant this product to the first consumer to be free from defect in material and workmanship for a period of one year from date of purchase. Please retain your sales slip for your records. Any product or part thereof found to be defective within that period will be replaced without charge provided that: (1) the product was not misused; (2) no alterations or modifications were made; (3) its failure resulted from a defect in material or workmanship and not from normal wear expected in the use of the product; (4) the product or part is delivered, freight prepaid, to Saris Products. Manufacturer's only obligation shall be to replace such products or parts proved to be defective.

Saris Cycling Group 5253 Verona Road Madison, WI 53711 (800) 783-7257 [www.sarisinfrastructure.com](http://www.sarisinfrastructure.com)