

WELDED PIPE FLOW THRU DIAPHRAGM SEAL

Reotemp's Welded Pipe Flow Thru Diaphragm Seals are ideal for installation in applications requiring little interruption to process flow and where all-welded piping connections are necessary. This style flow thru diaphragm seal can be made specific to the end-user's piping specification with socket and butt weld process connections.

DIAPHRAGM SEALS



W550



W560

FEATURES / BENEFITS

- Welded Diaphragm for Maximum Durability
- Wide Variety of Diaphragm and Material Options
- Continuous Flow Design Reduces Clogging Potential; Ideal for Slurries or High Viscosity Fluids
- Easy Cleanout of Diaphragm Cavity without Compromising Filled System

SPECIFICATIONS

Diaphragm 316SS, Hast C-276, Tantalum, Monel, or others

Lower Housing 316SS, Hast C-276, Monel, or others

Gasket PTFE, Grafoil, or Klinger

Upper Housing (Not Wetted) 316SS Standard

Process

Temperature Limits W550/W560

Metallic Lower	PTFE Gasket	-110/350°F
	Klinger Gasket	-110/450°F
	Grafoil Gasket	-40/600°F

Ambient Temperature Limits Determined by the pressure instrument.

Minimum

Recommended Span W550/W560

2.5" & 3.5" Gauges	15 psi
4", 4.5", & 6" Gauges	30 psi
Transmitter (Gauge Pressure)	150" H ₂ O
Transmitter (Differential Pressure)	300" H ₂ O _d
Differential Pressure Gauge (D40/42 Only)	N/A

Maximum Working Pressure at 100°F

	Bolts	Grade 8	316SS
Metallic Lower	W550/W560	2,500 psi	1,500 psi

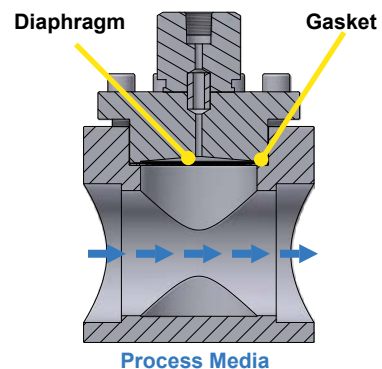
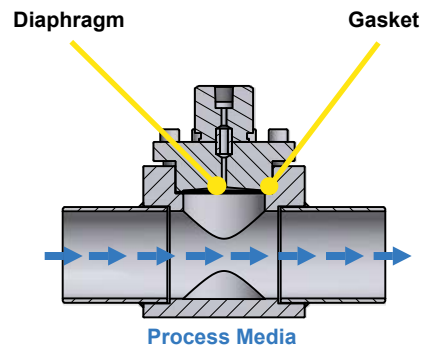

Need a replacement upper housing only? See the Saddle Seal Datasheet - Model W545

WELDED PIPE FLOW THRU DIAPHRAGM SEAL

HOW TO ORDER: Choose options to build a part number. For example: **W5502B1X11SSS-SKDTD-AS-PP**

SEAL TYPE	INSTRUMENT CONNECTION	SEALING TYPE	PIPE SIZE	MUST INCLUDE	END-TO-END	PIPE SCHEDULE	DIAPHRAGM MATERIAL	LOWER HOUSING
W550 = Butt Weld Flow Thru; Welded Diaphragm W560 = Socket Weld Flow Thru; Welded Diaphragm	2 = 1/2" FNPT 4 = 1/4" FNPT Transmitter Connection W = Low Volume	B = Butt Welded S = Socket Welded	0 = 1/2" T = 3/4" 1 = 1" H = 1.5" 2 = 2" 3 = 3" 4 = 4" 6 = 6" 8 = 8"	X	S = Standard "E" Dimension Per Drawing on Data-sheet Q = Custom Length	X = Must Select if Socket Weld Version 1 = Schedule 10 4 = Schedule 40 8 = Schedule 80 6 = Schedule 160 9 = Schedule XXS	S = 316SS U = Tantalum M = Monel (A400) D = Carpenter 20 H = Hast C-276 Y = Inconel (625) N = Nickel (201) 2 = Duplex (2205) J = Titanium* *Requires Titanium Upper Housing	S = 316SS M = Monel (A400) D = Carpenter 20 H = Hast C-276 Y = Inconel (625) N = Nickel (201) 2 = Duplex (2205) J = Titanium Wetted

DIAPHRAGM SEALS

UPPER HOUSING	BOLTING	GASKET	INSTRUMENT MOUNT	FILL FLUID	OPTIONS
S = 316SS F = 304SS J = Titanium* M = Monel H400 *Requires Titanium Diaphragm	-8 = Carbon Steel (Grade 8) -S = Stainless Steel (316)	K = Klinger (C-4401) T = PTFE G = Grafoil See Page 80 for Complete Gasket Selection Guide	Direct Mount DTD = Direct Mount, Threaded DWD = Direct Mount, Welded RTR = 6" Cooling Tower STW = 3" Cooling Standoff Remote Mount A?? = Armored Capillary, Threaded B?? = Armored Capillary, Welded P?? = PVC Coated Armor, Threaded W?? = PVC Coated Armor, Welded Note: ?? = Length in feet (e.g. 05 = 5 feet) Tree Mount LVC = Low Volume Goal Post Assembly; Vertical Mount; Gauge/Switch MVG = Compact Tree Assembly; Vertical Mount; Gauge/Switch YYY = Dry Seal, No Instrument See Page 79 for Complete Mounting Guide	Common Fills -AS = Silicone DC200 -AG = Glycerin USP -BP = Propylene Glycol -XX = No Fill Fluid See Fill Fluid Guide for All Options p.85	-PP = Pulse Plus™ (Pulsation Protection) -OX = Cleaned for Oxygen Service -AU = Gold-Plated Diaphragm -TC = Teflon-Coated Diaphragm -PM = Positive Material Identification Certification -MR = Mill Test Report -HT = Hydrostatic Test per ASME B31.3

WELDED PIPE FLOW THRU DIAPHRAGM SEAL

DIAPHRAGM SEALS

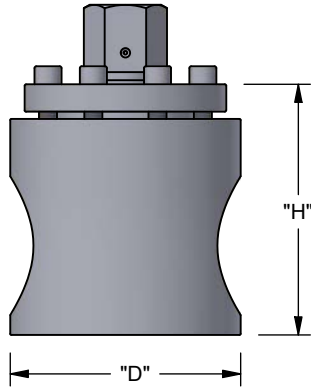

W560

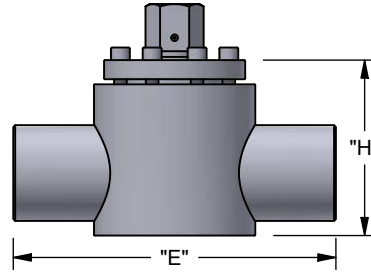

Style A W550

Socket Weld Flow Thru W560		
Pipe Size	H	D
1/4"	3.56"	3.5"
1/2"	3.56"	3.5"
3/4"	3.56"	3.5"
1"	3.56"	3.5"
1-1/2"	4.75"	4.0"
2"	4.75"	4.0"

Style A					
Pipe Size	Schedule	ID	E	H	D
1/4"	SCH10	0.41"	8"	2.7"	3.5"
1/4"	SCH40	0.36"	8"	2.7"	3.5"
1/4"	SCH80	0.3"	8"	2.7"	3.5"
1/2"	SCH10	0.67"	8"	2.7"	3.5"
1/2"	SCH40	0.62"	8"	2.7"	3.5"
1/2"	SCH80	0.55"	8"	2.7"	3.5"
1/2"	SCH160	0.46"	8"	2.7"	3.5"
3/4"	SCH10	0.88"	8"	3"	3.5"
3/4"	SCH40	0.82"	8"	3"	3.5"
3/4"	SCH80	0.74"	8"	3"	3.5"
3/4"	SCH160	0.61"	8"	3"	3.5"
1"	SCH10	1.1"	8"	3.2"	3.5"
1"	SCH40	1.05"	8"	3.2"	3.5"
1"	SCH80	0.96"	8"	3.2"	3.5"
1"	SCH160	0.82"	8"	3.2"	3.5"
1-1/2"	SCH10	1.68"	10"	3.9"	4.0"
1-1/2"	SCH40	1.61"	10"	3.9"	4.0"
1-1/2"	SCH80	1.5"	10"	3.9"	4.0"
1-1/2"	SCH160	1.34"	10"	3.9"	4.0"
2"	SCH10	2.16"	10"	4.4"	4.0"
2"	SCH40	2.07"	10"	4.4"	4.0"
2"	SCH80	1.94"	10"	4.4"	4.0"
2"	SCH160	1.69"	10"	4.4"	4.0"

WELDED PIPE FLOW THRU DIAPHRAGM SEAL

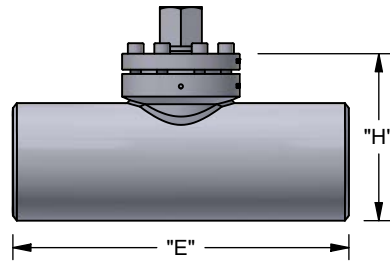

Style B W550

Style B					
Pipe Size	Schedule	ID	E	H	D
3"	SCH10	3.26"	10"	5"	3.5"
3"	SCH40	3.07"	10"	5"	3.5"
3"	SCH80	2.9"	10"	5"	3.5"
3"	SCH160	2.62"	10"	5"	3.5"

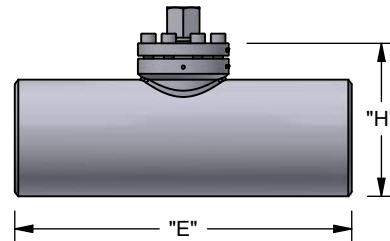

Style C W550

Style C					
Pipe Size	Schedule	ID	E	H	D
4"	SCH10	4.26"	10"	5.9"	3.5"
4"	SCH40	4.03"	10"	5.9"	3.5"
4"	SCH80	3.823"	10"	5.9"	3.5"
4"	SCH160	3.434"	10"	5.9"	3.5"
6"	SCH10	6.357"	10"	8"	3.5"
6"	SCH40	6.07"	10"	8"	3.5"
6"	SCH80	5.76"	10"	8"	3.5"
6"	SCH160	5.19"	10"	8"	3.5"
8"	SCH10	8.33"	10"	10"	3.5"
8"	SCH40	7.98"	10"	10"	3.5"
8"	SCH80	7.63"	10"	10"	3.5"
8"	SCH160	6.81"	10"	10"	3.5"

SMART TRANSMITTER ATTACHMENT

HOW TO ORDER: Unbalanced System Example

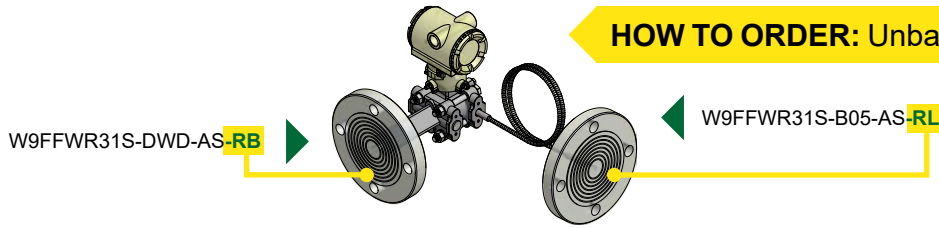

DIFFERENTIAL PRESSURE ASSEMBLY

Balanced System A complete assembly with one part number that includes two diaphragm seals, two capillaries, two fills, and one complete assembly calibration certificate.

Unbalanced DP System Where seal, mount, capillary, or fill is not identical. A complete assembly includes one diaphragm seal on the HP side AND one diaphragm seal on the LP side.

DIAPHRAGM SEALS

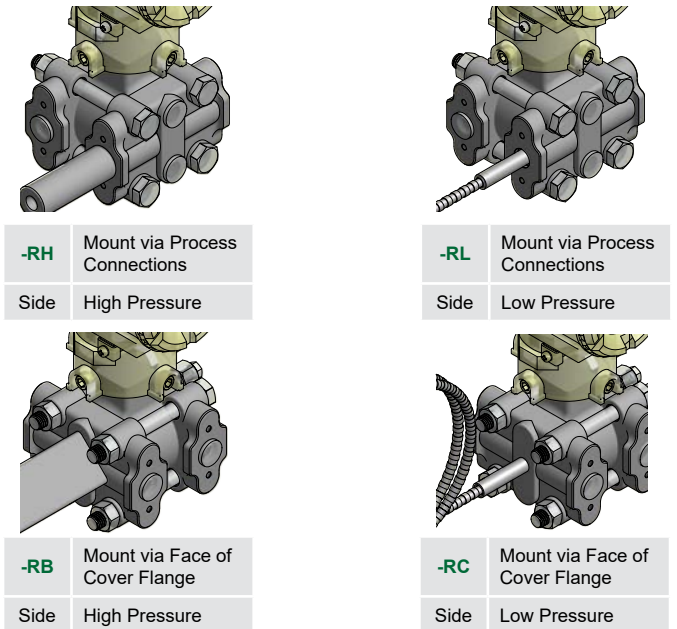
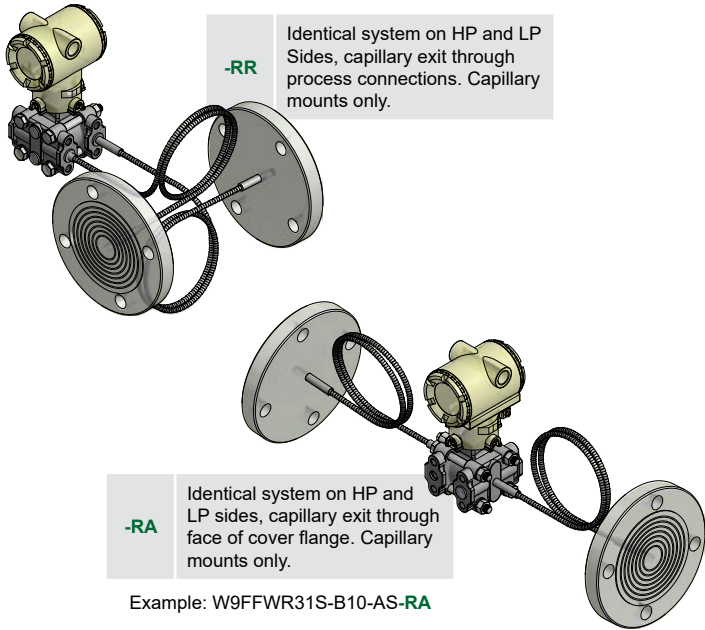

GAUGE PRESSURE ASSEMBLY

In Line Pressure Transmitter

Traditional Mount for Gauge Pressure Seal mount on one side only, other side is vented.

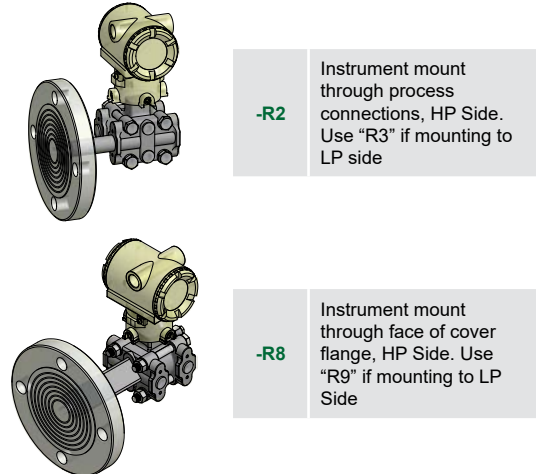
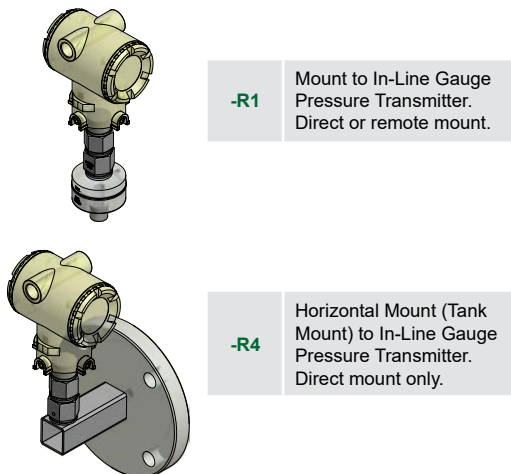

DIAPHRAGM SEAL ASSEMBLY TO SMART TRANSMITTERS

Reotemp specializes in the unique craft of assembling diaphragm seals to field transmitters for the purpose of measuring pressure, differential pressure, level, and flow. As a trusted supplier to many of the world's leading transmitter manufacturers, Reotemp can assemble a diaphragm seal system to virtually any make or model transmitter. Every transmitter mount includes the features below to ensure superior performance and durability for every assembly. Reotemp also offers repair, refurbishment or replacement of used transmitters with remote seals.

STANDARD FEATURES ON ALL REOTEMP ASSEMBLIES

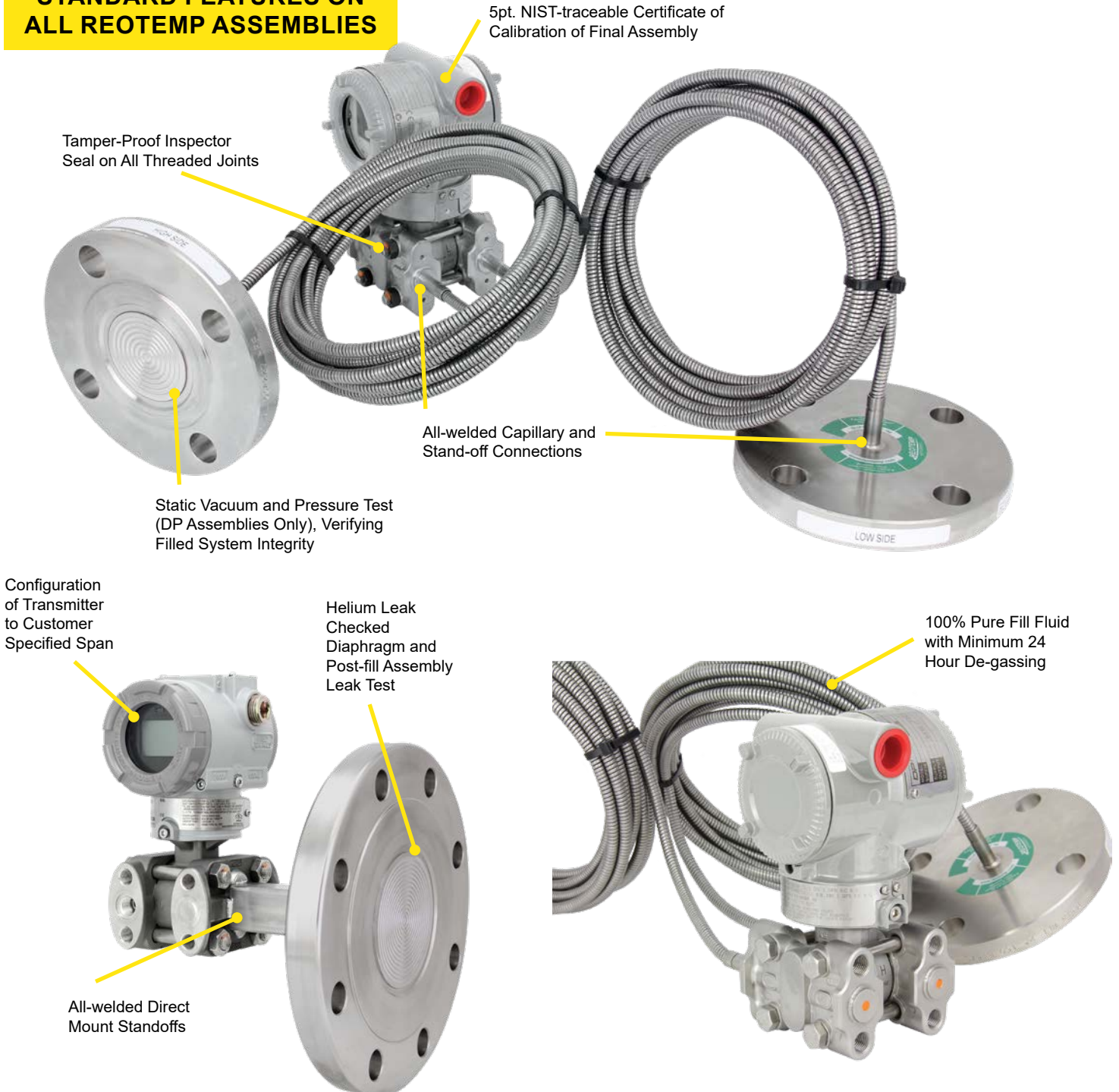

INSTRUMENT MOUNTING CONFIGURATIONS

DIRECT MOUNT

Direct Mounting a pressure gauge, switch, or transmitter is the most common diaphragm seal assembly.

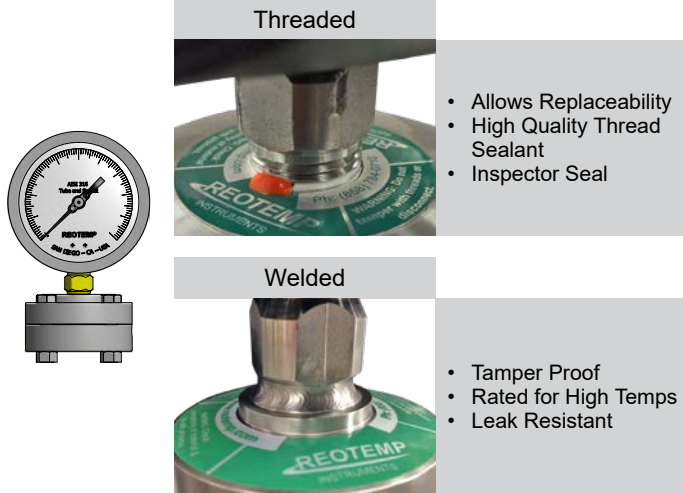

- Allows Replaceability
- High Quality Thread Sealant
- Inspector Seal

- Tamper Proof
- Rated for High Temps
- Leak Resistant

Code	Description	Max. Temp
-DTD	Threaded Instrument Connection	400°F
-DWD	Welded Instrument Connection	600°F

Assembly Notes: Welded connection recommended for pressure exceeding 1,500 psi for purposes of leak prevention.

COOLING ELEMENTS

Used in either high temp or cold temp applications, Cooling Elements mounted above diaphragm seals quickly normalize fluid temperature toward ambient. This protects the pressure instrument while still maintaining the convenience of a direct mount.

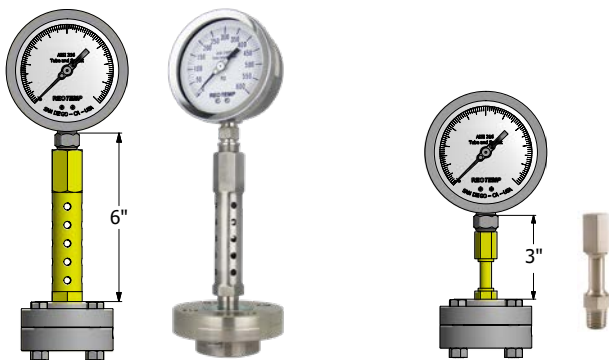

Code	Description	Max. Temp
-RTR	6" Cooling Tower	750°F
-STW	3" Cooling Standoff	600°F

Assembly Notes: Cooling elements are welded to diaphragm seal. Instruments are threaded to cooling element unless specified. All lengths are nominal.

REMOTE MOUNT

Remote Mounting a pressure instrument using flexible capillary is a common mounting method when the point of measurement is in a hazardous or inconvenient location.

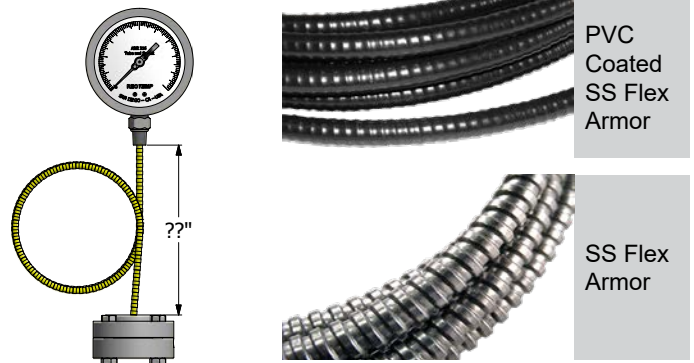

Code	Description	Max. Temp
-P??	PVC Coated SS Armor, Threaded to Seal	400°F
-W??	PVC Coated SS Armor, Welded to Seal	600°F
-A??	SS Flexible Armor, Threaded to Seal	400°F
-B??	SS Flexible Armor, Welded to Seal	750°F

Note: ?? = Length in feet (e.g. 05 = 5 feet)

Assembly Notes: Capillary has a 2mm inner diameter unless specified differently by customer. Ambient temp limit of PVC coated armor is 250°F. Standard instrument connection is threaded (Smart Transmitters are welded), unless specified by customer.

TREE ASSEMBLIES

Tree Assemblies offer the ability to mount two pressure instruments onto one diaphragm seal, allowing the user to gain both a local indication and a remote signal without adding an additional pipe insertion.

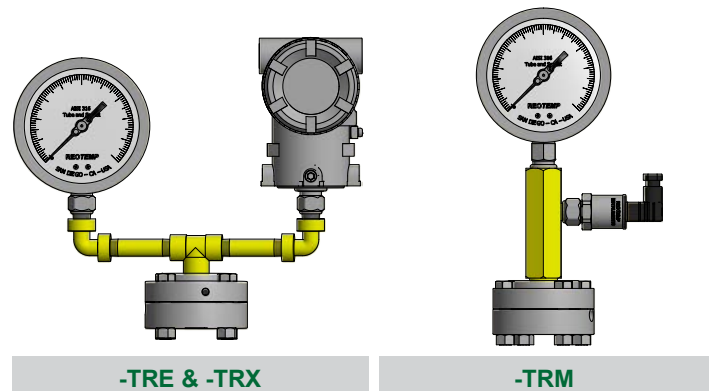

Code	Description	Max. Temp
-TRE	Goal Post, Low Pressure Assembly (Max. 150 psi)	400°F
-TRX	Goal Post, Heavy Duty (Max. 3,000 psi)	600°F
-TRM	Compact Tree Assembly (Max. 3,000 psi)	600°F

Assembly Notes: Threaded joints are fully welded for consistent instrument orientation. Instrument connections are threaded unless specified by customer. Diaphragm seal must displace enough fluid to drive both instruments.

DIAPHRAGM SEALS

GASKET SELECTION GUIDE

Gasket selection depends on your process temperature, reactivity and other variables. For most applications Klinger is standard however suitability for process is determined by the customer.

GASKET SELECTION CHART					
Material	Maximum Temperature (°F)	Minimum Temperature (°F)	Description	Common Applications	Cost
Klinger C4401	500°F	-110°F	Compressed aramid synthetic fiber reinforced with a nitrile binder. Excellent sealability and general purpose use	Mild inorganic and organic acids, concentrated and diluted alkalies, water, brine, industrial gases, oils, refrigerants, petroleum and derivatives	Low
Grafoil	750°F	-40°F	Made of pure compressed homogenous graphite flake with a corrosion inhibitor. Contains no binders or resins. Very fragile with very low tensile strength and elasticity	Elevated temperature processes, aggressive and corrosive chemicals, Nuclear	Medium
Viton	400°F	-10°F	Fluorinated synthetic polymer or fluoroelastomer that contains excellent elasticity, tensile strength, and sealability as well as good medium temperature resistance	Variety of acids and bases, animal and vegetable oils, hydrocarbons	Low
Virgin PTFE	400°F	-150°F	Polytetrafluoroethylene Resin. Exceptional chemical resistance. Poor cold flow and relaxation properties	Inert to nearly all chemicals	Medium
Kalrez	620°F	30°F	High temperature resistant perfluoroelastomer with excellent tensile strength, sealability, and elasticity	Oxidizing and Reactive Chemicals, Steam, Alcohols, Aldehydes, Ethers, Esters, Ketones, Acids and Bases	Very High
Top Chem 2000	450°F	-150°F	PTFE filled with silicone carbide (SiC). Excellent Sealability and improved relaxation resistance over PTFE	Strong acids and alkalines, Steam, Motor fuel and oils, Aromates, Esters, Ketones, Alcohols	High
Gylon 3510	500°F	-150°F	PTFE filled with barium sulfate. Good Sealability as well as improved relaxation and cold flow resistance versus PTFE	Strong caustics, hydrocarbons, steam, chlorine, moderate acids, cryogenics, aluminum fluoride	High
Silver Ag 3N5	750°F	-150°F	99.95% pure silver (Ag) sheet. Exceptional sealability and use in extreme temperature and pressure applications. Only gasket that can be re-used in certain conditions	Extreme Temperatures and Pressures, Cryogenics, Nuclear, Deep Vacuum, Solvents, Alcohols, Steam, Silicone, Vegetable and Petroleum oils, Fuels	Very High
Buna-N	200°F	-20°F	Also known as NBR, is a black nitrile synthetic rubber compound with excellent elasticity, tensile strength, and abrasion resistance, but exhibits poor elevated temperature characteristics	Petroleum-Based and Synthetic Oils, Alcohols, Hydraulic Fluids, Fuels, Water, Silicone Greases, Solvents	Low
EPDM	200°F	-20°F	Ethylene Propylene Diene Monomer Rubber. Good elasticity, Tensile Strength, and Sealability. Exhibits limited elevated temperature resistance.	Silicone and Vegetable oils, Ketones, Esters, Alkalies, Most Acids, Water	Low

Re-use: Re-use subject to gasket condition and presence of corrosion or pitting on mating parts. Only recommended for up to three re-use cycles. Re-assembly of the diaphragm seal to be performed per Reotemp standards and procedures to ensure proper seating.

Max Working Pressure: Gasket Selection does not impact the MWP of the configured diaphragm seal.

Process Compatibility: The listed common applications are to be used as a guide only. Actual chemical compatibility of the process with the chosen gasket material should be approved by qualified personnel.

FILL GUIDE

Diaphragm seals are designed to protect pressure instruments from hot process media and corrosive chemicals while minimizing any negative effect on instrument accuracy and durability. A well-made diaphragm seal can achieve this goal only if it is properly assembled, filled, and tested. Reotemp's highly trained technicians use state-of-the-art equipment so that every diaphragm seal assembly is filled and tested to assure optimal instrument performance:

- ✓ 24-hour Minimum Fluid De-gassing
- ✓ Evacuated Instrument Chamber Up to 10⁻⁸ mbar Absolute
- ✓ Complete Fill Integrity Check
- ✓ Fill-port Leak Test
- ✓ Post-fill Static Test
- ✓ Verification of Instrument Calibration
- ✓ High-temp Pipe Sealant Option for Joints
- ✓ Tamper-proof (Inspection Seal) Lacquer used on All Threaded Joints
- ✓ Sturdy Diaphragm Packaging Protection

Part Number Code	Name	Description	Temperature Range (Vacuum Service <5psia)		Viscosity cst @ -77°F	Specific Gravity @ -77°F	Thermal Expansion cc/cc°C
STANDARD FILL FLUID							
AS	Silicone DC200 ¹	This is the standard fill fluid for most diaphragm seal applications.	-40°F to 400°F (-40°F to 250°F)	Yes	20	0.94	.00104
HIGH TEMP SILICONE							
BH	Silicone DC704 ¹	Standard for Smart Transmitters and capillary systems. Performs well in applications with high temperature and a deep vacuum.	0°F to 650°F (0°F to 450°F)	No	44	1.07	.00077
B1	Silicone DC710 ¹	Highest temperature rating; ideal for gauge seal assemblies. Too thick for capillary assemblies. Response time can become very slow in cold conditions.	50°F to 750°F (50°F to 400°F)	Yes	500	1.11	.00043
C8	Syltherm 800 ²	Low viscosity allows it to perform well in both low and high temperatures. Not recommended for vacuum service or at high temperatures when under low static pressure.	-40°F to 750°F (-40°F to 150°F)	No	9.5	0.93	.00136
B5	Silicone DC705 ¹	Performs very well in high temperatures when under vacuum. The high viscosity and freezing point of this fluid makes it a poor choice for cold or outdoor installations without heat tracing.	50°F to 675°F (50°F to 550°F)	Yes	175	1.09	.00096
B2	Silicone DC550 ¹	Similar high temperature performance as DC705, however it performs better at lower temperatures.	-40°F to 575°F (-40°F to 400°F)	No	125	1.07	.00076
FOOD GRADE							
AG	Glycerin USP	This is the standard fill fluid for most gauge seal assemblies for food, beverage, and pharmaceutical applications. Its high viscosity will cause very slow response at times in low temperature and outdoor installations.	60°F to 450°F (Not Suitable)	Yes	1100	1.26	.00061
BN	NEOBEE M20 ⁷	Low viscosity and a wide temperature range makes this the standard sanitary fill fluid for Smart Transmitters and capillary systems.	-10°F to 400°F (-10°F to 200°F)	No	10	0.92	.00101
BS	Food Grade Silicone	Highest temperature limit for food grade fluids. Because of its high viscosity it does not perform well in low temperatures.	20°F to 550°F (20°F to 250°F)	Yes	350	0.97	.00096
BP	Propylene Glycol	This is the fill fluid used when Glycol is called for on the customer specification. It has a very narrow temperature range.	0°F to 200°F (Not Suitable)	No	2.85	1.03	.00073
INERT (TYPICALLY FOR CHLORINE AND OXYGEN APPLICATIONS OR IN SILICONE-FREE ENVIRONMENTS)							
C1	Fomblin Y06 ⁴	Ideal inert fluid for transmitter applications. Relatively high vapor pressure above 200°F. Not recommended for use in high temperature situations with low static pressure.	-40°F to 450°F (0°F to 250°F)	No	71	1.88	.00086
C2	Halocarbon 6.3 ³	Standard inert fluid used in gauge seal assemblies.	-40°F to 400°F (-40°F to 200°F)	Yes	6.3	1.87	.00084
C3	Halocarbon 1.8 ³	Typically used in low temperature applications because of its low viscosity.	-110°F to 220°F (-100°F to 100°F)	No	1.8	1.82	.00084
C4	Fluorolube FS-5 ⁵	Similar performance to Halocarbon 6.3, however not suitable for vacuum service.	-40°F to 450°F (Not Suitable)	No	5	1.86	.00087
SPECIALTY							
CK	Krytox 1506 ⁶	Specialty fill fluid, inert.	-40°F to 350°F (-40°F to 300°F)	No	62	1.88	.00095
BE	Ethylene Glycol	Occasionally used in annular (O-ring) seal assemblies.	-25°F to 320°F (Not Suitable)	No	30	1.10	.00062
CT	Syltherm XLT ²	Used for very low process temperatures.	-150°F to 500°F (Not Suitable)	No	1.4	0.85	.00168

1 Trademark Dow Corning

3 Trademark Halocarbon Product Corporation

5 Trademark Hooker Chemical Company

7 Trademark Stepan Specialty Products

2 Trademark The Dow Chemical Company

4 Trademark AUSIMONT S.P.A

6 Trademark The Chemours Company FC, LLC

Note: PulsePlus™ fill fluids may have different physical properties than specified. Chemical composition and temperature ranges do not vary.

DIAPHRAGM SEALS

DIAPHRAGM SEALS