

## EXTENDED DIAPHRAGM SEAL

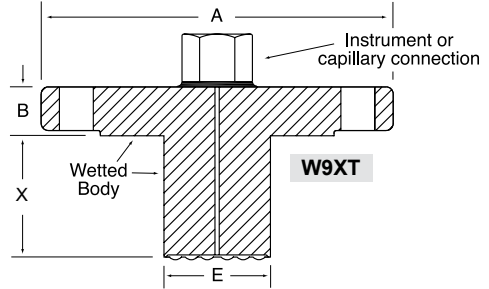

W9XT

The Extended Diaphragm Seal is ideal for highly viscous and dry powder applications. Its unique design eliminates dead space in piping. It is often used for flush mounting in thick-walled vessels and is available in standard and custom lengths.



DIAPHRAGM SEALS

### SPECIFICATIONS

<b>Wetted Materials</b>	316L or Hast C-276		
<b>Process</b>	-110°F to 750°F		
<b>Temperature Limits</b>			
<b>Ambient</b>	Determined by the pressure instrument.		
<b>Temperature Limits</b>			
<b>Minimum Recommended Span</b>	2"	3"	4"
Transmitter (Gauge Pressure)	200 "H <sub>2</sub> O	100 "H <sub>2</sub> O	30 "H <sub>2</sub> O
Transmitter (Differential Pressure)	200 "H <sub>2</sub> O <sub>d</sub>	150 "H <sub>2</sub> O <sub>d</sub>	30 "H <sub>2</sub> O <sub>d</sub>

### Dimensions:

Flange Rating	A	B	E*
1.5"	5"	0.70"	1.40"
2"	150#	6"	0.75"
	300#	6.5"	0.88"
3"	150#	7.5"	0.94"
	300#	8.25"	1.13"
4"	150#	9"	0.94"
	300#	10"	1.19"
6"	150#	11"	0.94"

NOTE: Dimensions are for raised face flanges only. Other flange sizes and sealing face info can be found in ANSI B16.5 standards.

\*Extension diameter meant to fit SCH80 Nozzle. Custom extension diameters available.

**HOW TO ORDER:** Choose options to build a part number. For example: **W9XTWR31SSS020-W10-AS-DG**

MODEL	INSTRUMENT CONNECTION	SEALING FACE	PIPE SIZE	FLANGE RATING	DIAPHRAGM MATERIAL	EXTENSION MATERIAL
<b>W9XT</b>	<b>W</b>	<b>R</b>	<b>3</b>	<b>1</b>	<b>S</b>	<b>S</b>
<b>W9XT</b> = Flanged Extended Diaphragm	<b>W</b> = Low-Volume Connection for Smart Transmitters <b>2</b> = 1/2" NPT Female <b>4</b> = 1/4" NPT Female	<b>R</b> = Raised Face <b>J</b> = Ring Type Joint	<b>H</b> = 1.5" Pipe <b>2</b> = 2" Pipe <b>3</b> = 3" Pipe <b>4</b> = 4" Pipe <b>6</b> = 6" Pipe	<b>1</b> = 150# ANSI <b>3</b> = 300# ANSI <b>6</b> = 600# ANSI	<b>S</b> = 316LSS <b>H</b> = Hastelloy C-276 Wetted	<b>S</b> = 316LSS <b>H</b> = Hastelloy C-276 Wetted
FLANGE/SEALING FACE MATERIAL	EXTENSION LENGTH (X)	MOUNTING	FILL FLUID	OPTIONS		
<b>S</b> = 316LSS <b>H</b> = Hast. C-276 Wetted	<b>020</b> = 2" <b>040</b> = 4" <b>060</b> = 6" ??? = Enter Custom Length in Inches Note: ??? = Length in inches (e.g. 020 = 2 inches).	<b>-DWD</b> = Direct Mount, All Welded <b>-RTR</b> = 6" Cooling Tower, Welded <b>-B??</b> = SS Armored Capillary, Welded <b>-W??</b> = PVC Coated SS Armored Capillary, Welded Note: ?? = Length in feet (e.g. 05 = 5 feet) See Page 57 for Complete Mounting Guide	<b>-AS</b> = Silicone DC200 <b>-AG</b> = Glycerin USP <b>-BH</b> = Silicone DC704 <b>-C1</b> = Fomblin Y06 (inert) <b>-C2</b> = Halocarbon 6.3 See Page 58 for Complete Fill Guide	<b>-DG</b> = Degreased and Bagged <b>-AU</b> = Gold Plated Diaphragm (20 Microns Thick) <b>-TS</b> = SS Tag (1-10 Characters) See Page 55 for Smart Transmitter Attachment Codes		

## SMART TRANSMITTER ATTACHMENT

### HOW TO ORDER: Unbalanced System Example

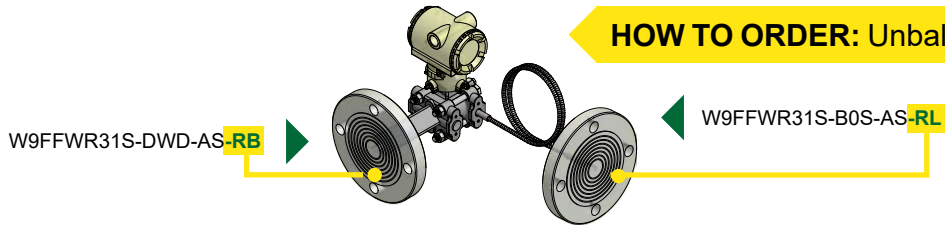

### DIFFERENTIAL PRESSURE ASSEMBLY

**Balanced System** A complete assembly with one part number that includes two diaphragm seals, two capillaries, two fills, and one complete assembly calibration certificate.

**Unbalanced DP System** Where seal, mount, capillary, or fill is not identical. A complete assembly includes one diaphragm seal on the HP side AND one diaphragm seal on the LP side.

DIAPHRAGM SEALS

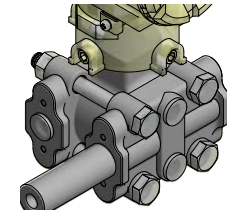
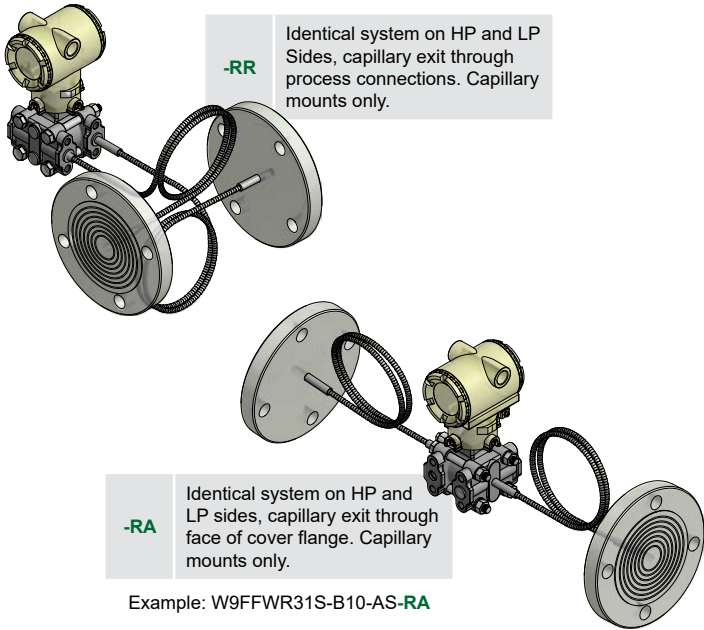

**-RH** Mount via Process Connections  
Side High Pressure

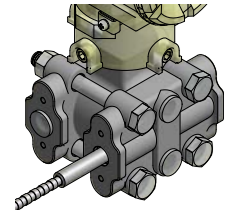

**-RL** Mount via Process Connections  
Side Low Pressure

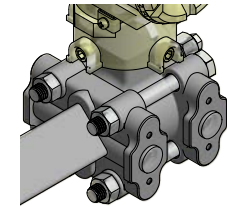

**-RB** Mount via Face of Cover Flange  
Side High Pressure

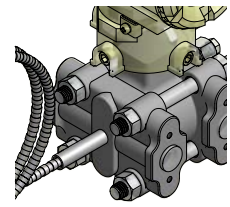

**-RC** Mount via Face of Cover Flange  
Side Low Pressure

### GAUGE PRESSURE ASSEMBLY

#### In Line Pressure Transmitter

**Traditional Mount for Gauge Pressure** Seal mount on one side only, other side is vented.



**-R1** Mount to In-Line Gauge Pressure Transmitter. Direct or remote mount.

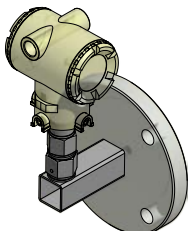

**-R4** Horizontal Mount (Tank Mount) to In-Line Gauge Pressure Transmitter. Direct mount only.

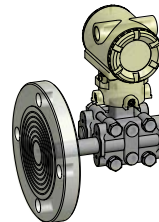

**-R2** Instrument mount through process connections, HP Side. Use "R3" if mounting to LP side

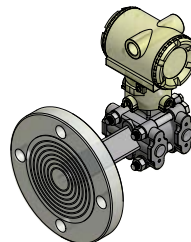

**-R8** Instrument mount through face of cover flange, HP Side. Use "R9" if mounting to LP Side

## DIAPHRAGM SEAL ASSEMBLY TO SMART TRANSMITTERS

REOTEMP specializes in the unique craft of assembling diaphragm seals to field transmitters for the purpose of measuring pressure, differential pressure, level, and flow. As a trusted supplier to many of the world's leading transmitter manufacturers, REOTEMP can assemble a diaphragm seal system to virtually any make or model transmitter. Every transmitter mount includes the features below to ensure superior performance and durability for every assembly. REOTEMP also offers repair, refurbishment or replacement of used transmitters with remote seals.

### STANDARD FEATURES ON ALL REOTEMP ASSEMBLIES

5pt. NIST-traceable Certificate of Calibration of Final Assembly

Vacuum Evacuated Fluid and Instrument Chamber to  $1 \times 10^{-8}$  mbar Absolute

Tamper-Proof Inspector Seal on All Threaded Joints

All-welded Capillary and Stand-off Connections

Static Vacuum and Pressure Test (DP Assemblies Only), Verifying Filled System Integrity

Configuration of Transmitter to Customer Specified Span

Helium Leak Checked Diaphragm and Post-fill Assembly Leak Test

100% Pure Fill Fluid with Minimum 24 Hour De-gassing

All-welded Direct Mount Standoffs (2mm ID Capillary Inside for Fill Fluid Minimization)

Low Volume Modification to Factory Cover Flanges

DIAPHRAGM SEALS

## INSTRUMENT MOUNTING CONFIGURATIONS

### DIRECT MOUNT

Direct Mounting a pressure gauge, switch, or transmitter is the most common diaphragm seal assembly.

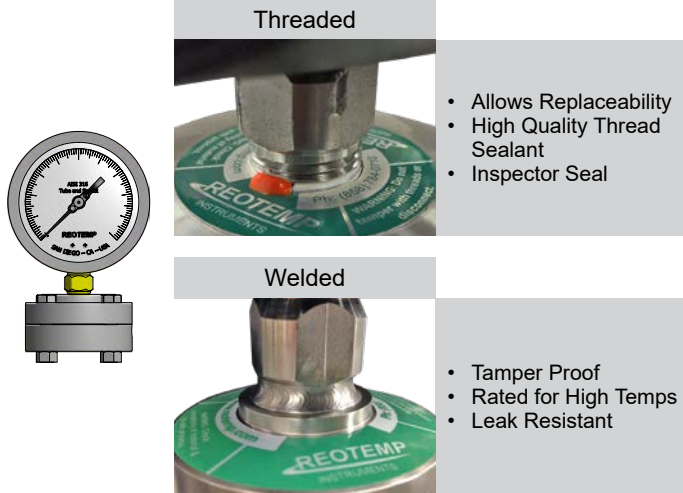

- Allows Replaceability
- High Quality Thread Sealant
- Inspector Seal

- Tamper Proof
- Rated for High Temps
- Leak Resistant

Code	Description	Max. Temp
-DTD	Threaded Instrument Connection	400°F
-DWD	Welded Instrument Connection	600°F

**Assembly Notes:** Welded connection recommended for pressure exceeding 1,500 psi for purposes of leak prevention.

### COOLING ELEMENTS

Used in either high temp or cold temp applications, Cooling Elements mounted above diaphragm seals quickly normalize fluid temperature toward ambient. This protects the pressure instrument while still maintaining the convenience of a direct mount.

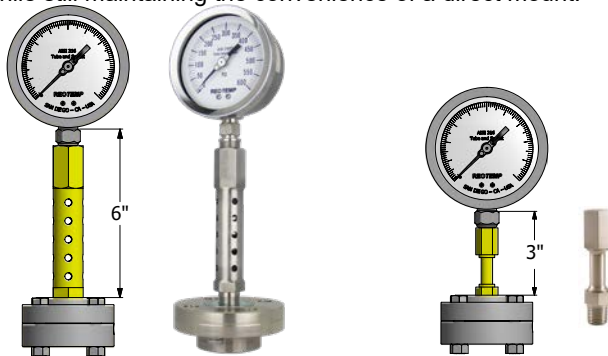

Code	Description	Max. Temp
-RTR	6" Cooling Tower	750°F
-STW	3" Cooling Standoff	600°F

**Assembly Notes:** Cooling elements are welded to diaphragm seal. Instruments are threaded to cooling element unless specified. All lengths are nominal.

### REMOTE MOUNT

Remote Mounting a pressure instrument using flexible capillary is a common mounting method when the point of measurement is in a hazardous or inconvenient location.

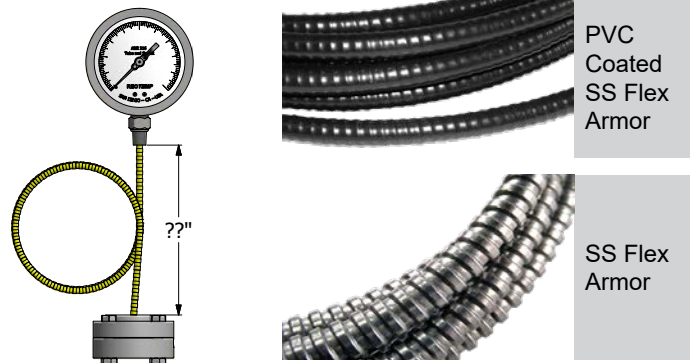

Code	Description	Max. Temp
-P??	PVC Coated SS Armor, Threaded to Seal	400°F
-W??	PVC Coated SS Armor, Welded to Seal	600°F
-A??	SS Flexible Armor, Threaded to Seal	400°F
-B??	SS Flexible Armor, Welded to Seal	750°F

Note: ?? = Length in feet (e.g. 05 = 5 feet)

**Assembly Notes:** Capillary has a 2mm inner diameter unless specified differently by customer. Ambient temp limit of PVC coated armor is 250°F. Standard instrument connection is threaded (Smart Transmitters are welded), unless specified by customer.

### TREE ASSEMBLIES

Tree Assemblies offer the ability to mount two pressure instruments onto one diaphragm seal, allowing the user to gain both a local indication and a remote signal without adding an additional pipe insertion.

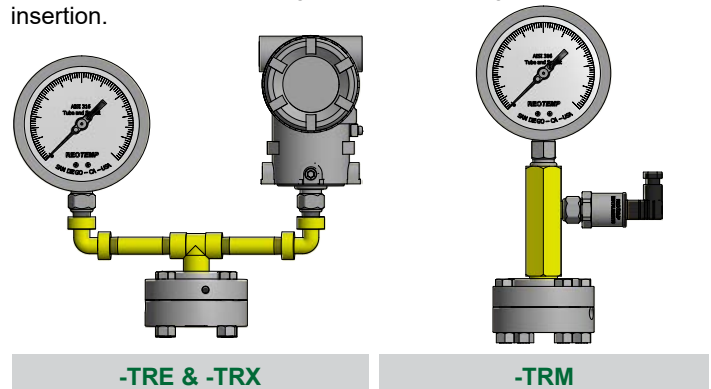

Code	Description	Max. Temp
-TRE	Goal Post, Low Pressure Assembly (Max. 150 psi)	400°F
-TRX	Goal Post, Heavy Duty (Max. 3,000 psi)	600°F
-TRM	Compact Tree Assembly (Max. 3,000 psi)	600°F

**Assembly Notes:** Threaded joints are fully welded for consistent instrument orientation. Instrument connections are threaded unless specified by customer. Diaphragm seal must displace enough fluid to drive both instruments.

DIAPHRAGM SEALS

## FILL GUIDE

Diaphragm seals are designed to protect pressure instruments from hot process media and corrosive chemicals while minimizing any negative effect on instrument accuracy and durability. A well-made diaphragm seal can achieve this goal only if it is properly assembled, filled, and tested. REOTEMP's highly trained technicians use state-of-the-art equipment so that every diaphragm seal assembly is filled and tested to assure optimal instrument performance:

- ✓ 24-hour Minimum Fluid De-gassing
- ✓ Evacuated Instrument Chamber Up to 10<sup>-8</sup> mbar Absolute
- ✓ Complete Fill Integrity Check
- ✓ Fill-port Leak Test
- ✓ Post-fill Static Test
- ✓ Verification of Instrument Calibration
- ✓ High-temp Pipe Sealant Used on All Threaded Joints
- (Welded Joints Upon Request)
- ✓ Tamper-proof (Inspection Seal) Lacquer used on All Threaded Joints
- ✓ Sturdy Diaphragm Packaging Protection



Part Number Code	Name	Description	Temperature Range (Vacuum Service <5psia)	Pulse+	Viscosity cst @ ~77°F	Specific Gravity @ ~77°F	Thermal Expansion cc/cc°C
<b>STANDARD FILL FLUID</b>							
AS	Silicone DC200 <sup>1</sup>	This is the standard fill fluid for most diaphragm seal applications.	-40°F to 400°F (-40°F to 250°F)	Yes	20	0.94	.00104
<b>HIGH TEMP SILICONE</b>							
BH	Silicone DC704 <sup>1</sup>	Standard for Smart Transmitters and capillary systems. Performs well in applications with high temperature and a deep vacuum.	0°F to 650°F (0°F to 450°F)	No	44	1.07	.00077
B1	Silicone DC710 <sup>1</sup>	Highest temperature rating; ideal for gauge seal assemblies. Too thick for capillary assemblies. Response time can become very slow in cold conditions.	50°F to 750°F (50°F to 400°F)	Yes	500	1.11	.00043
C8	Syltherm 800 <sup>2</sup>	Low viscosity allows it to perform well in both low and high temperatures. Not recommended for vacuum service or at high temperatures when under low static pressure.	-40°F to 750°F (-40°F to 150°F)	No	9.5	0.93	.00136
B5	Silicone DC705 <sup>1</sup>	Performs very well in high temperatures when under vacuum. The high viscosity and freezing point of this fluid makes it a poor choice for cold or outdoor installations without heat tracing.	50°F to 675°F (50°F to 550°F)	Yes	175	1.09	.00096
B2	Silicone DC550 <sup>1</sup>	Similar high temperature performance as DC705, however it performs better at lower temperatures.	-40°F to 575°F (-40°F to 400°F)	No	125	1.07	.00076
<b>FOOD GRADE</b>							
AG	Glycerin USP	This is the standard fill fluid for most gauge seal assemblies for food, beverage, and pharmaceutical applications. Its high viscosity will cause very slow response at times in low temperature and outdoor installations.	60°F to 450°F (Not Suitable)	Yes	1100	1.26	.00061
BN	NEOBEE M20 <sup>7</sup>	Low viscosity and a wide temperature range makes this the standard sanitary fill fluid for Smart Transmitters and capillary systems.	-10°F to 400°F (-10°F to 200°F)	No	10	0.92	.00101
BS	Food Grade Silicone	Highest temperature limit for food grade fluids. Because of its high viscosity it does not perform well in low temperatures.	20°F to 550°F (20°F to 250°F)	Yes	350	0.97	.00096
BP	Propylene Glycol	This is the fill fluid used when Glycol is called for on the customer specification. It has a very narrow temperature range.	0°F to 200°F (Not Suitable)	No	2.85	1.03	.00073
<b>INERT (TYPICALLY FOR CHLORINE AND OXYGEN APPLICATIONS OR IN SILICONE-FREE ENVIRONMENTS)</b>							
C1	Fomblin Y06 <sup>4</sup>	Ideal inert fluid for transmitter applications. Relatively high vapor pressure above 200°F. Not recommended for use in high temperature situations with low static pressure.	-40°F to 450°F (0°F to 250°F)	No	71	1.88	.00086
C2	Halocarbon 6.3 <sup>3</sup>	Standard inert fluid used in gauge seal assemblies.	-40°F to 400°F (-40°F to 200°F)	Yes	6.3	1.97	.00084
C3	Halocarbon 1.8 <sup>3</sup>	Typically used in low temperature applications because of its low viscosity.	-110°F to 220°F (-100°F to 100°F)	No	1.8	1.82	.00084
C4	Fluorolube FS-5 <sup>5</sup>	Similar performance to Halocarbon 6.3, however not suitable for vacuum service.	-40°F to 450°F (Not Suitable)	No	5	1.86	.00087
<b>SPECIALTY</b>							
CK	Krytox 1506 <sup>6</sup>	Specialty fill fluid, inert.	-40°F to 350°F (-40°F to 300°F)	No	62	1.88	.00095
BE	Ethylene Glycol	Occasionally used in annular (O-ring) seal assemblies.	-25°F to 320°F (Not Suitable)	No	30	1.10	.00062

1 Trademark Dow Corning

3 Trademark Halocarbon Product Corporation

5 Trademark Hooker Chemical Company

7 Trademark Stepan Specialty Products

2 Trademark The Dow Chemical Company

4 Trademark AUSIMONT S.P.A

6 Trademark The Chemours Company FC, LLC

Note: PulsePlus™ fill fluids may have different physical properties than specified. Chemical composition and temperature ranges do not vary.

## DIAPHRAGM SEAL OPTIONS



Visit [reotemp.com](http://reotemp.com)

- ✓ Check Stock
- ✓ Get Price
- ✓ Configure Part #
- ✓ Download PDF Data Sheets

DIAPHRAGM SEALS

		MS4 MS6 MS8	W5 W6 W7	T5 T6 V5	W9FF W9FR	W9XT	W9FP	DSTC75	DSTC15 AND LARGER	DSTF05	DSTF75 AND LARGER	OR	DXFR
<b>PULSATION PROTECTION (ONLY AVAILABLE WITH REOTEMP PRESSURE GAUGE MOUNTED TO SEAL)</b>													
-PP	Pulse Plus™	✓	✓	✓	✓	✓	N/A	N/A	✓	N/A	✓	✓	N/A
<b>DIAPHRAGM COATING</b>													
-AU	Gold Plated Diaphragm	N/A	✓	N/A	✓	✓	✓	✓	✓	✓	✓	N/A	N/A
-TC	Teflon Coated Diaphragm PTFE	N/A	✓	N/A	✓	✓	✓	N/A	✓	N/A	✓	N/A	N/A
-EP	Electropolished Diaphragm	N/A	N/A	N/A	N/A	N/A	N/A	✓	✓	✓	✓	N/A	N/A
<b>FILL</b>													
-FW	Fill Port Welded Closed	STD <sup>1</sup>	✓	✓	✓	✓	✓	✓	✓	✓	✓	N/A	N/A
-VF	Fill for Vacuum Service	N/A	✓	N/A	✓	✓	✓	N/A	✓	N/A	✓	N/A	N/A
<b>CLEANING AND FINISH</b>													
-DG	Degreased, Shipped in Sealed Bag	✓	✓	✓	✓	✓	✓	✓	✓	✓	✓	N/A	✓
-OX	Cleaned for Oxygen Service per ASME B40.1	✓	✓	N/A	✓	✓	✓	✓	✓	✓	✓	N/A	✓
-OY	Cleaned for Oxygen Service per MIL-STD-1330D	✓	✓	N/A	✓	✓	✓	✓	✓	✓	✓	N/A	✓
<b>PLUG FOR FLUSH PORT</b>													
-GS	1/4" SS Plug Installed	STD	STD	STD	N/A	N/A	N/A	N/A	N/A	N/A	N/A	N/A	✓
-JS	1/2" SS Plug Installed	N/A	STD	STD	N/A	N/A	N/A	N/A	N/A	N/A	N/A	N/A	✓
-GH	1/4" Hast C Plug Installed	✓	✓	✓	N/A	N/A	N/A	N/A	N/A	N/A	N/A	N/A	✓
-JH	1/2" Hast C Plug Installed	N/A	✓	✓	N/A	N/A	N/A	N/A	N/A	N/A	N/A	N/A	✓
-GM	1/4" Monel Plug Installed	N/A	✓	✓	N/A	N/A	N/A	N/A	N/A	N/A	N/A	N/A	✓
-JM	1/2" Monel Plug Installed	N/A	✓	✓	N/A	N/A	N/A	N/A	N/A	N/A	N/A	N/A	✓
<b>TAG OPTION</b>													
-TS	Stainless Steel Tag (1-10 Characters)								✓				
-TM	Stainless Steel Tag (11-80 Characters)								✓				
-TP	Paper Tag								✓				
<b>CERTIFICATION OPTIONS</b>													
-NC	Certificate of NACE Compliance	✓	✓	N/A	✓	✓	✓	N/A	N/A	✓	✓	N/A	✓
-CM	General Material Conformance	✓	✓	✓	✓	✓	✓	✓	✓	✓	✓	✓	✓
-MR	MTR - Mill Test Report Certificate	✓	✓	✓	✓	✓	✓	✓	✓	✓	✓	N/A	✓
-PM	PMI - Positive Material Identification Certificate	✓	✓	✓	✓	✓	✓	✓	✓	✓	✓	N/A	✓
-HT	Hydrostatic Test per ASME B31.3	✓	✓	✓	✓	✓	✓	✓	✓	✓	✓	N/A	N/A
-HL	Helium Leak Test Certificate	✓	✓	N/A	✓	✓	✓	✓	✓	✓	✓	N/A	N/A

✓ Indicates that the option is available  
 N/A Indicates the option is not available

<sup>1</sup> Standard on MS8, available on MS4 & MS6.