



1059, boulevard des Entreprises Ouest
 Terrebonne, QC Canada J6Y 1V2
 Tel 450-628-1006 1.800.783.6883
 Fax 450-628-7801 1.888.783.6883
 www.plasticase.com

CUBED FOAM INSERT 962_NANUK

PROJECT PRODUCT

00962_NANUK_p.01

DWG ID **962-FOAM**

STATUS

YOUR SIGNATURE IS REQUIRED FOR APPROVAL BEFORE ANY RELEASE OF PRODUCTION DRAWINGS

TOLERANCES

CUTOUTS +/- 1/16

OVERALL FOAM THICKNESS & CAVITY DEPTHS +/- 1/8

SIGNATURE

DATE

GLUED TO CASE TOP BASE VELCRO EXTRA

REVISIONS

REV.	DESCRIPTION	DATE	INIT
a.01	GENERAL MODIFICAITON	2022-04-25	JG
p.00	MISE EN PRODUCTION VERSION a.02	2022-08-30	WV
p.01	LID MODIIFCATION	2022-10-25	WV

LID TRAY - ELEVATION

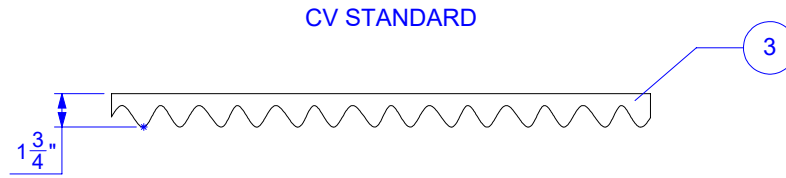

BASE TRAY

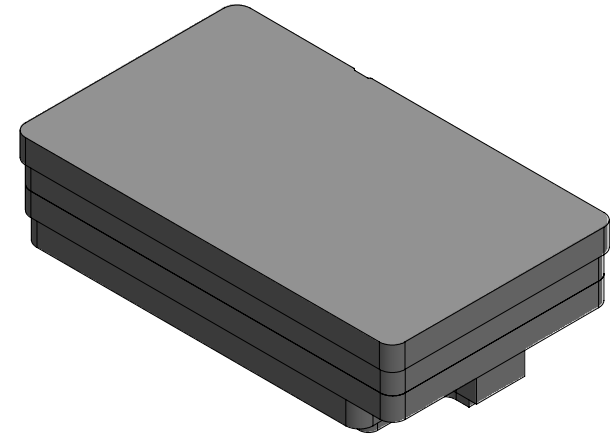
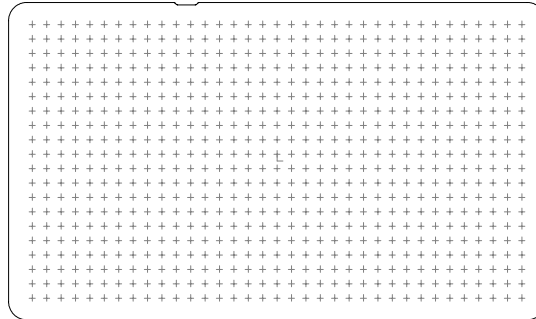

BASE TRAY - ELEVATION

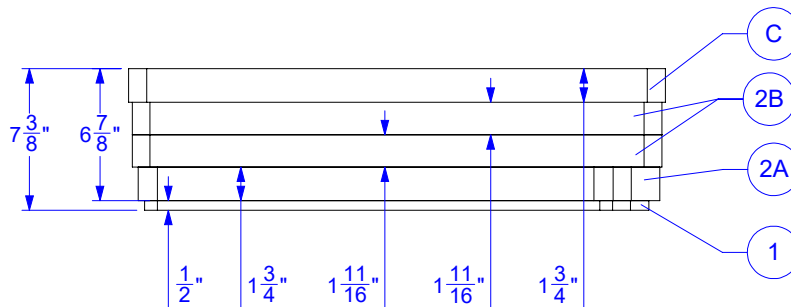

FOAM DENSITY MAY VARY
DIMENSIONS ARE IN INCHES UNLESS OTHERWISE SPECIFIED

PROPRIETARY AND CONFIDENTIAL

THE INFORMATION CONTAINED IN THIS DRAWING IS THE SOLE & EXCLUSIVE PROPERTY OF PLASTICASE INC.
 ANY REPRODUCTION IN PART OR WHOLE WITHOUT THE WRITTEN PERMISSION OF PLASTICASE INC. IS PROHIBITED.

DO NOT SCALE DRAWING
 SHEET SCALE 1:10

Frank Vitiello
 REPRESENTATIVE

Jérémy Gauthier
 DESIGNER

2022-10-25
 DATE

1/8

YOUR SIGNATURE IS REQUIRED FOR APPROVAL BEFORE ANY RELEASE OF PRODUCTION DRAWINGS

TOLERANCES

CUTOUTS +/- 1/16

OVERALL FOAM THICKNESS & CAVITY DEPTHS +/- 1/8

SIGNATURE

DATE

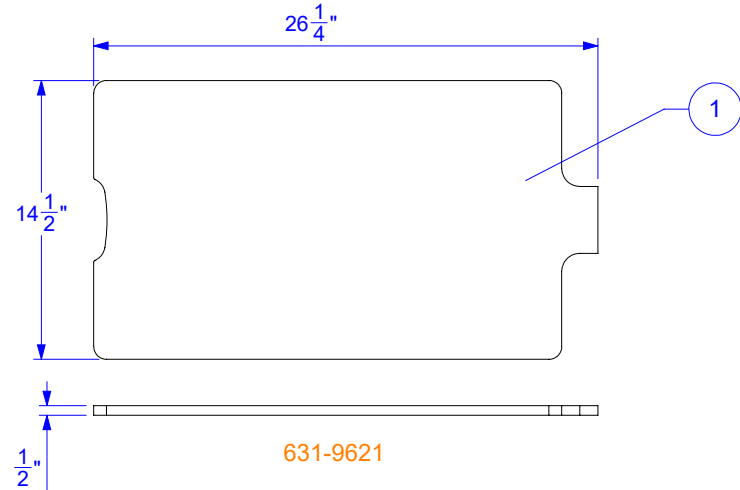

631-9621
 PUF P150-55 BLK MATERIAL 1 QTY

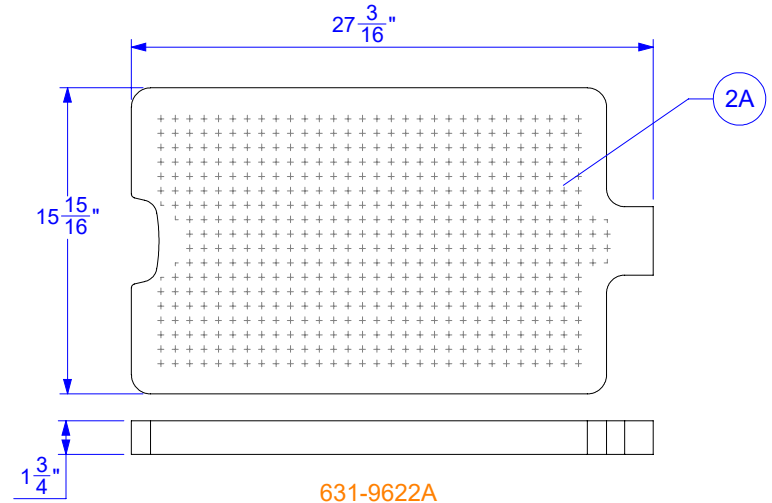

631-9622A
 PUF P150-55 BLK MATERIAL 1 QTY

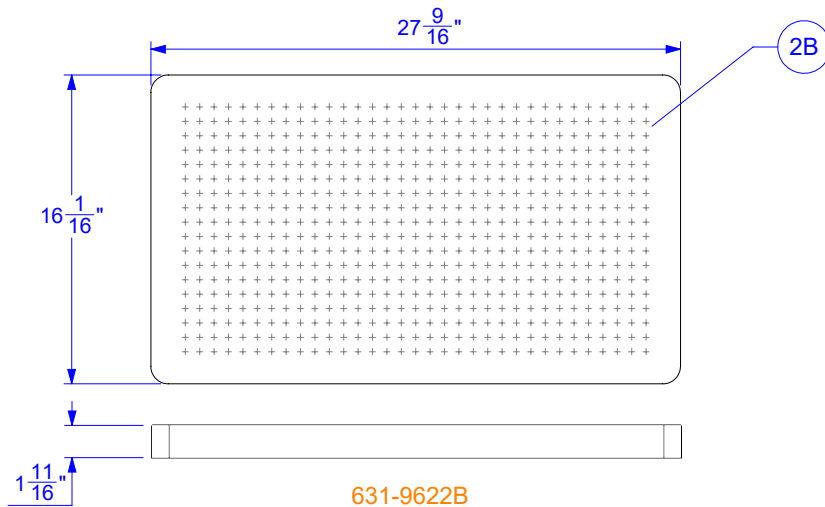

631-9622B
 PUF P150-55 BLK MATERIAL 2 QTY

FOAM DENSITY MAY VARY. DIMENSIONS ARE IN INCHES UNLESS OTHERWISE SPECIFIED



1059, boulevard des Entreprises Ouest
 Terrebonne, QC Canada J6Y 1V2
 Tel 450-628-1006 1.800.783.6883
 Fax 450-628-7801 1.888.783.6883
 www.plasticase.com

EGGSHELL 962

PROJECT

962_NANUK

PRODUCT

00962_NANUK_p.01

DWG ID

STATUS

YOUR SIGNATURE IS REQUIRED FOR APPROVAL BEFORE ANY RELEASE OF PRODUCTION DRAWINGS

TOLERANCES

CUTOUTS +/- 1/16

OVERALL FOAM THICKNESS & CAVITY DEPTHS +/- 1/8

SIGNATURE

DATE

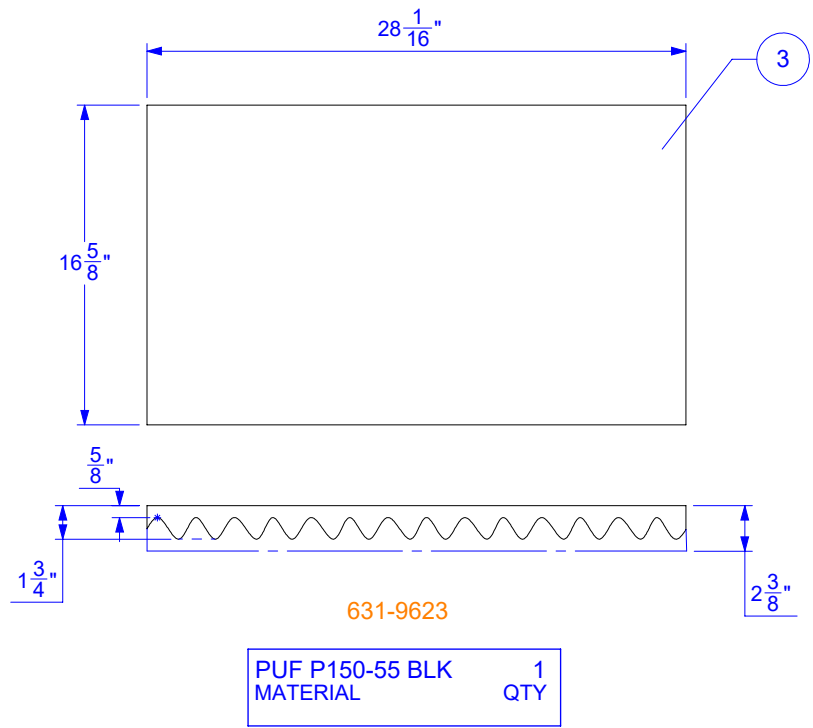
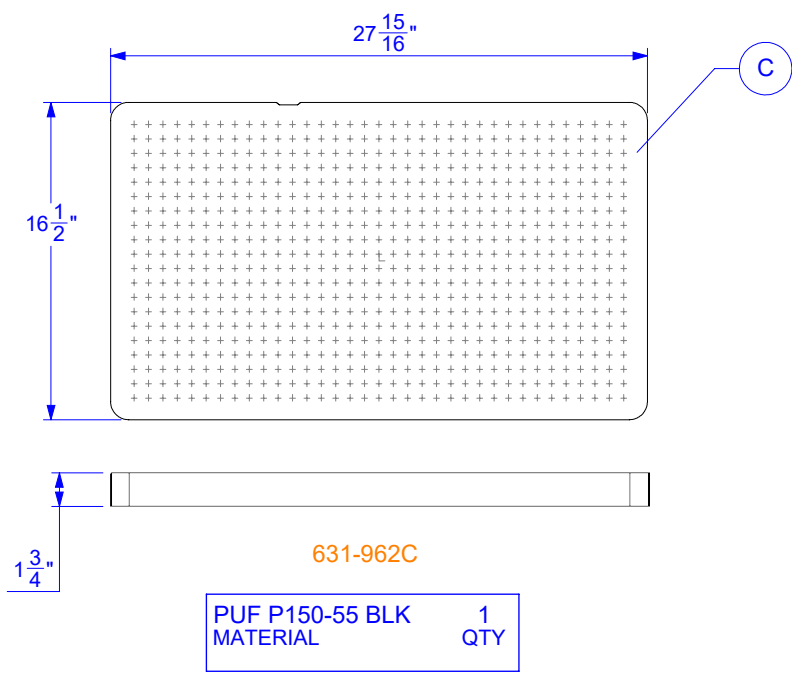

FOAM DENSITY MAY VARY. DIMENSIONS ARE IN INCHES UNLESS OTHERWISE SPECIFIED

PROPRIETARY AND CONFIDENTIAL

THE INFORMATION CONTAINED IN THIS DRAWING IS THE SOLE & EXCLUSIVE PROPERTY OF PLASTICASE INC. ANY REPRODUCTION IN PART OR WHOLE WITHOUT THE WRITTEN PERMISSION OF PLASTICASE INC. IS PROHIBITED.

DO NOT SCALE DRAWING
 SHEET SCALE 1:10

Frank Vitiello
 REPRESENTATIVE

Jérémy Gauthier
 DESIGNER

2022-10-25
 DATE