

CVO FIRE 



BIO ETHANOL FIRES

HIGH EFFICIENCY

BIO ETHANOL FIREPLACES EXPLAINED

THE TECHNOLOGY: The fires operate with a special alcohol fuel which is manufactured from plants. This fuel is clean burning. Bio ethanol fireplaces do not require a chimney or a flue system and are classed as 100% efficient as the heat paid for in burning the fuel returns to the room. Normal ventilation in the room is sufficient to remove any emissions. Most bio ethanol fireplaces are easy to install and use. Many models are freestanding however other models can be mounted on to a wall or recessed into the wall. Our range includes both manual and remote control burners.

WHY CHOOSE A BIO ETHANOL FIREPLACE FROM CVO FIRE: We are a UK company with sales consultants available on the telephone 01325-301020 to help and guide you through the requirements and technology. Bio ethanol fireplaces can be viewed "live" in our FIREVAULT fireplace showroom in the North East just off the A1 Motorway at J59. Unit 4, Beaumont Square, Durham Way South, Newton Aycliffe, Co Durham, DL5 6XN. As a UK manufacturing company we are also able manufacture bespoke burners and enclosures upon request.

QUESTIONS ANSWERED:

What fuel do these type of fireplaces use? Bio ethanol fireplaces use a specially formulated bio-fuel, which produces real flames and real heat. It is advised to use good quality bio-fuel. There are many brands on the market and the results achieved from them vary greatly.

What are the positive aspects of this type of Fire? Bio ethanol fireplaces provide a decorative form of heating for homes without a gas supply or chimney. This means they can be used in most places where installing a gas or wood burning fire would cost too much. This style of fireplace is classed as a 100% energy efficient form of heating therefore the fuel you pay for stays in the room and is not wasted up a chimney.

What are the negative aspects of this type of Fire? The running costs can be higher per KW of heat when compared to other heating systems. The actual cost will depend on the size of burner chosen. The burner trays we sell include special ceramic matting which improves the fuel usage and stabilises the flame. The liquid fuel is a flammable liquid therefore consideration must be given to where this is stored. It is advised to keep the fuel outside in a store and only bring in small amounts to use when required. A bio ethanol fireplace cannot be used to heat your entire home, they are decorative fires for use for short periods when extra heat is required in a room.

Do I need a chimney or a flue system? No.

What is the heat output? This depends on the size of the burner that is chosen. The wider the burner flame then the higher the heat output and increased running costs. It is best to choose a model which will give a steady heat to ensure you get maximum comfort from the fire. Call our sales team with your room dimensions and we can quote the most suitable design to choose.

What are the running costs? As above this depends on the size of the burner and also the quality of the fuel purchased. Cheap fuel may not give the same heat output and may not last as long as a quality fuel.

Is there any smoke or smell? Under normal usage, with good quality liquid bio ethanol fireplace fuel there will be no smoke. A slight smell can sometimes be noticed after the fire has been extinguished and will disperse quickly. As advised above the quality of the fuel has a great effect on the flame quality, smoke and smells. The quality of the fuel is the most critical factor when operating this type of fire. Never use "gel fuel" in any of our fires. Gel fuel should only be used outside as it can create smoke and harmful emissions. Never use gel fuel in a fire designed for bio ethanol fuel.

Are bio ethanol fireplaces safe? Bio ethanol fireplaces have been available in the USA for over 20 years and are growing in popularity in the UK and Europe. They are widely used in countries like Germany. The fireplaces we sell are tested and designed to be as safe as possible, stable and secure. Normal common sense and adherence to Health and Safety is required when dealing with a naked flame and handling flammable liquids and caution has to be exercised especially where young children and elderly people are in the vicinity. Our fires have been designed to a high standard and have been tested for safety and durability. To ensure your safety, you should only use liquid fuel designed for bio ethanol fireplaces and no other chemical or substance should be placed in the burner. Bio ethanol fireplaces should never be refilled or moved when hot or still lit.

How do I install my fireplace? Always read the manufacturers installation instructions before installing and using a bio-fuel fire. With some models a builder will be required to construct a non-combustible chamber in which to house the burner. Installation instructions are included with the fire.

Do you make custom or bespoke designs? We are renowned for creating stunning, desirable fireplaces. Our clients are based around the world and our fires are specified by top designers and architects. Our bespoke fires are designed to a high standard and we will not compromise on style or materials just to make a fireplace "cheaper". We can design a custom made fireplace however this will involve development costs. If you have a specific requirement and a budget to match please call our sales advisors who can discuss your project in detail and suggest the best and most cost effective solution.





CVO-1000 BIO ETHANOL FIRE Hole in the wall design.

DESCRIPTION

The CVO-1000 bio ethanol ribbon burner is clean burning and has a 100% efficiency rating and has been designed for use in homes where a larger heat source is required.

This contemporary fireplace design is manufactured in the UK. There is no need for a gas supply or chimney. The fire has a heat output (on full) of approximately 6kw this can be reduced by partially closing the lid to reduce the flame.

The burner is manufactured from very high grade brushed stainless steel and is supplied with a safety tray. The burner features our special ceramic matting which will stabilise the flame and extend the burn time.

The CVO-1000 can be supplied with a wide range of standard single sided and double-sided enclosures in polished, brushed, or black steel. The standard enclosure has an opening of 1200mm x 400mm x 300mm. By buying the enclosure and burner together installation is straightforward.

“Built in, Flueless, Smokeless, Eco and environmentally friendly”

- Ribbon burner for use with bio ethanol fuel for fireplaces.
- The heat output on full is approx 6.0kw, reduced by partially closing lid.
- The burner is supplied with a Safety Tray which must be used.
- The burner incorporates ceramic matting to increase burn time.
- Tray capacity is 3 Litres [maximum] - Do Not Overfill Tray.
- The burn time on full is approximately 3-4 hours.
- The burner time can be extended by partially closing the lid.

OPTIONS:

- The overall size of the burner and safety tray is 993mm x 193mm with a depth of 50mm.
- The burner is 100% energy efficient as the heat generated stays in the room or property.

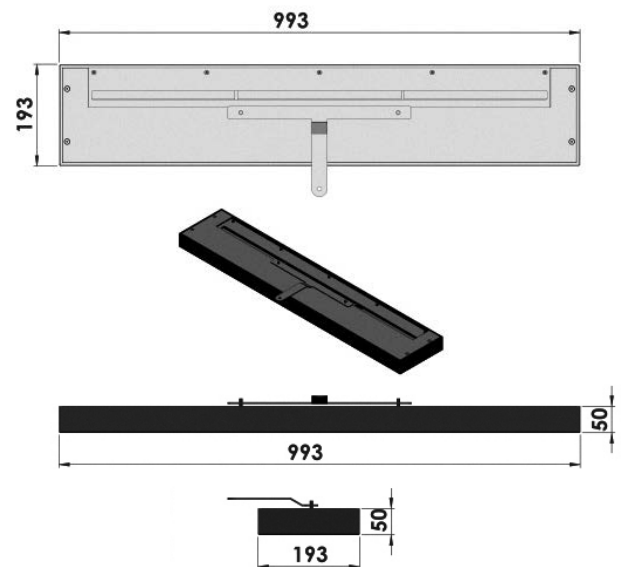

- The burner is suitable for use in a custom designed fireplace or can be purchased with one of our standard single sided or double-sided enclosures.
- We can also manufacture bespoke enclosures upon request.
- As this is a very large burner some room ventilation will be required, this can be provided by partially opening a window.
- If purchasing just the burner the buyer must use the burner in a fireplace opening made of non-combustible materials with clearances to combustible materials.
- Consult the installation booklet supplied with the tray and building regulations.
- No building work should be started until the tray is on site and the installation instructions have been received and consulted.
- Visit our YouTube page for a video of this fire working.
- Visit the www.easyfire.co.uk web site for technical and installation manual.

For other bio ethanol models and to buy fuel visit: www.easyfire.co.uk



CVO-600 BIO ETHANOL FIRE

Hole in the wall design.

DESCRIPTION

The CVO-600 bio ethanol ribbon burner is clean burning and has a 100% efficiency rating and has been designed for use in homes where a heat source is required without a gas supply.

This contemporary fireplace design is manufactured in the UK. There is no need for a gas supply or chimney. The fire has a heat output (on full) of approximately 4kw this can be reduced by partially closing the lid to reduce the flame.

The burner is manufactured from very high grade brushed stainless steel and is supplied with a safety tray. The burner features our special ceramic matting which will stabilise the flame and extend the burn time.

The CVO-600 can be supplied with a wide range of standard single sided and double-sided enclosures in polished, brushed, or black steel. The standard enclosure has an opening of 800mm x 400mm x 260mm. By buying the enclosure and burner together installation is straightforward.

“Built in, Flueless, Smokeless, Eco and environmentally friendly”

- Ribbon burner for use with bio ethanol fuel for fireplaces.
- The heat output on full is approx 4.0kw, reduced by partially closing lid.
- The burner is supplied with a Safety Tray which must be used.
- The burner incorporates ceramic matting to increase burn time.
- Tray capacity is 2 Litres [maximum] - Do Not Overfill Tray.
- The burn time on full is approximately 2-3 hours.
- The burner time can be extended by partially closing the lid.

OPTIONS:

- The overall size of the burner and safety tray is 600mm x 193mm with a depth of 50mm.



- The burner is 100% energy efficient as the heat generated stays in the room or property.
- The burner is suitable for use in a custom designed fireplace or can be purchased with one of our standard single sided or double-sided enclosures.
- We can also manufacture bespoke enclosures upon request.
- As this is a large burner some room ventilation will be required, this can be provided by partially opening a window.
- If purchasing just the burner the buyer must use the burner in a fireplace opening made of non-combustible materials with clearances to combustible materials.
- Consult the installation booklet supplied with the tray and building regulations.
- No building work should be started until the tray is on site and the installation instructions have been received and consulted.
- Visit our YouTube page for a video of this fire working.
- Visit the www.easyfire.co.uk web site for technical and installation manual.

For other bio ethanol models and to buy fuel visit: www.easyfire.co.uk

OVAL FIRE BOWLS

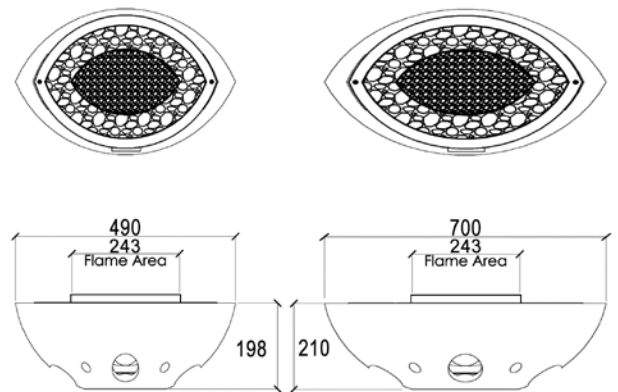

Weight: 25kg
Material: bowl in white, black, aluminium or bronze

FIRE VESSEL

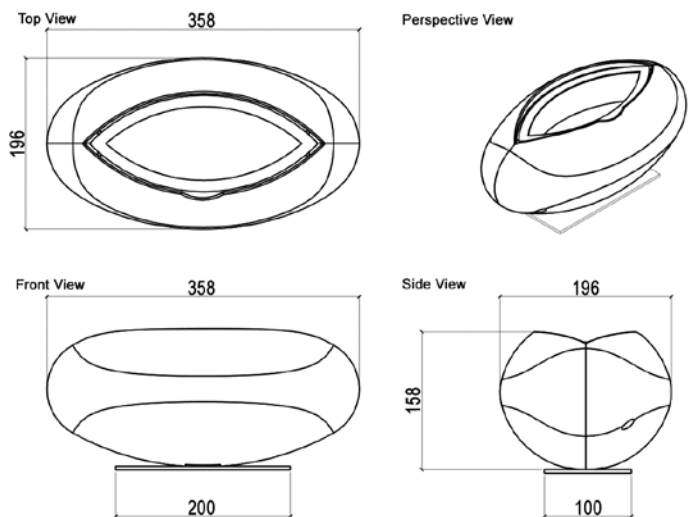

Weight: 10kg
Material: polished aluminium, polished bronze

FRANCESCA

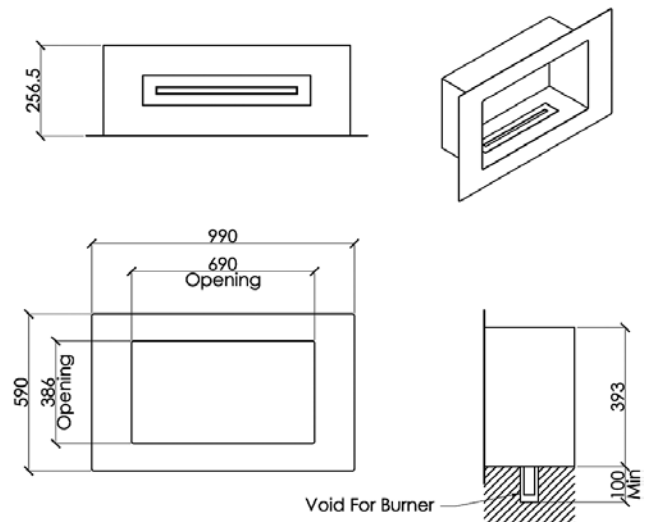

Weight: 15kg
Material: black painted steel with brushed or black fascia



REMOTE CONTROL BIO ETHANOL BURNER TRAYS

DESCRIPTION

Remote control bio ethanol trays are high quality ribbon burner inserts, operated by remote control and have a 240v power supply.

These high quality remote burners are built to the latest safety standards and are available in 7 sizes from 660mm wide to 2300mm wide.

The remote bio ethanol burners have heat outputs ranging from 3.8Kw (660) to 15.6Kw (2300).

These remote control bio ethanol ribbon burner inserts are ideal for custom made fireplace designs and can be used homes, bars, hotels and restaurants.

With sizes up to 2300mm wide and high tray capacities a stunning feature fireplace can be designed. With a wide range of standard enclosures.

AVAILABLE IN SIZES:

- 660 Dimensions = 660 x 240 x 135 mm
- 820 Dimensions = 820 x 240 x 215mm
- 1000 Dimensions = 1000 X 240 X 215mm
- 1200 Dimensions = 1220 x 240 x 215mm
- 1500 Dimensions = 1520 x 240 x 215mm
- 1800 Dimensions = 1820mm x 240mm x 215mm
- 2300 Dimensions = 2300mm x 240mm x 215mm



CATALINA



Black

Weight: 17kg
 Material: black painted steel
 Option: glass protection screen

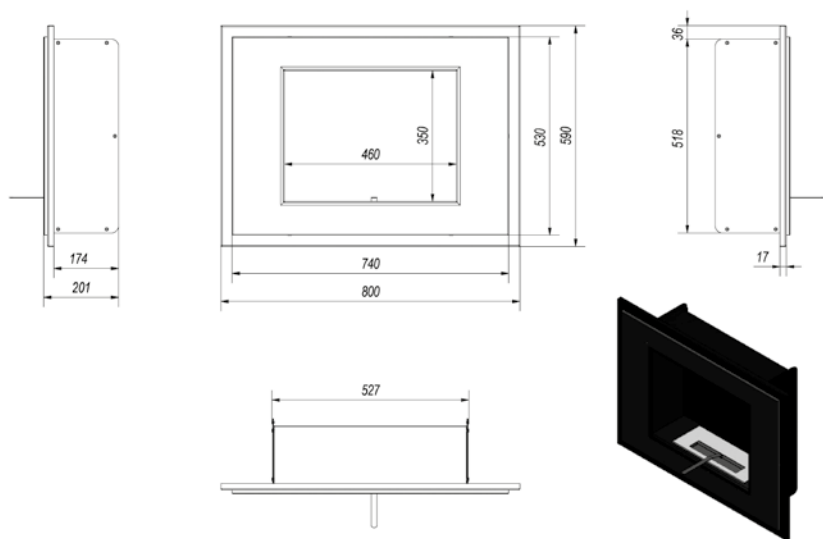

AVONDALE



Brushed Steel

Black

Weight: 23.5kg
 Material: black painted steel with various fascia options (see
 Option: glass protection screen

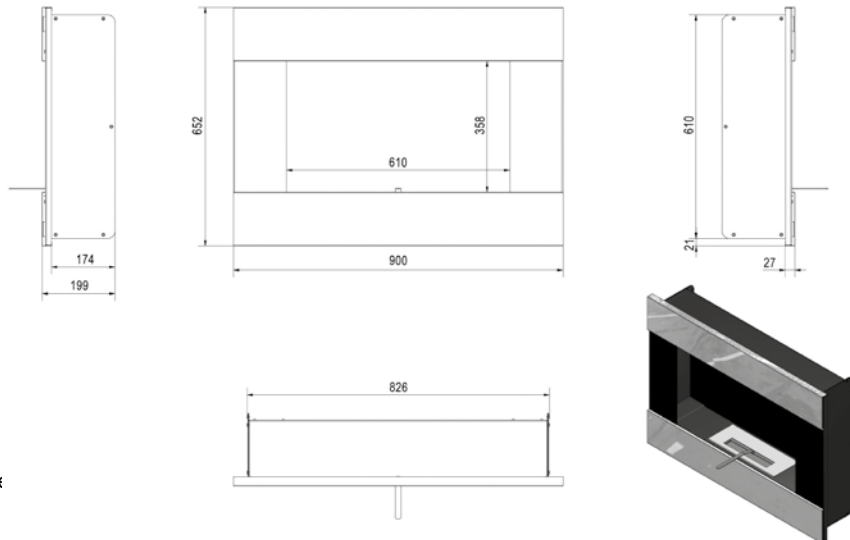

CASA GRANDE



Black

Weight: 23kg
 Material: black painted steel
 Option: glass protection screen

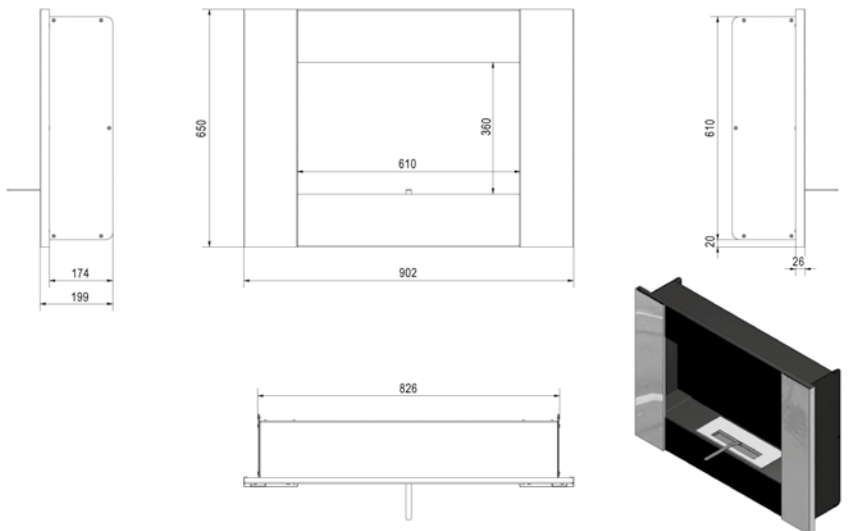



WELLTON



Black

Weight: 14.5kg
Material: black painted steel
Option: glass protection screen

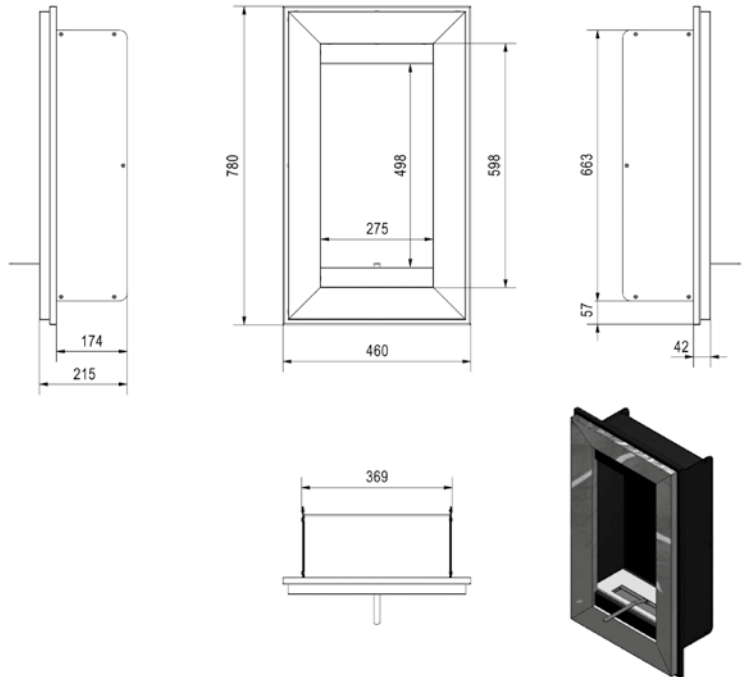

DILKON



Black

Weight: 20kg
Material: black painted steel
Option: glass protection screen

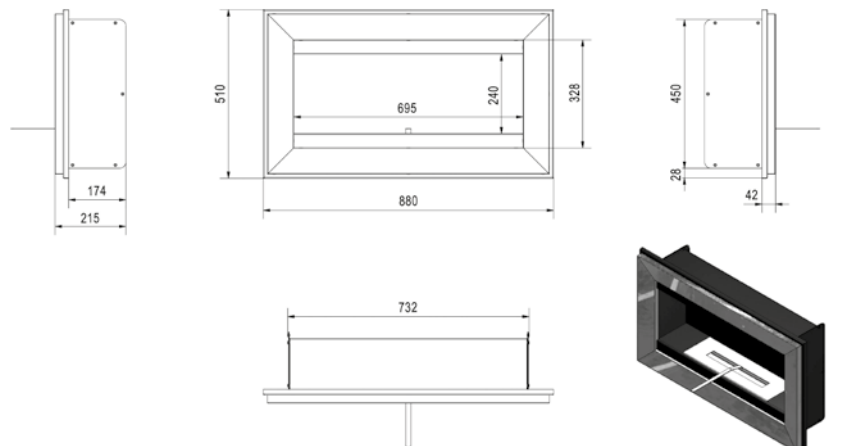

CARE FREE



Black

Weight: 7kg
 Material: black painted steel
 Option: glass protection screen

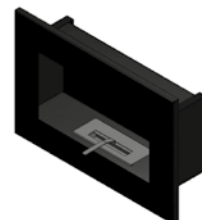
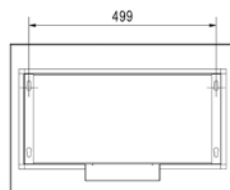
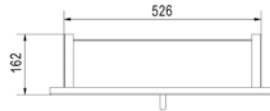
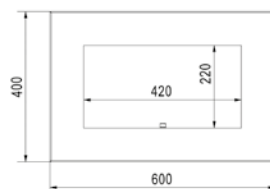

DOUGLAS



Black



QUBE

HORIZONTAL

STAINLESS

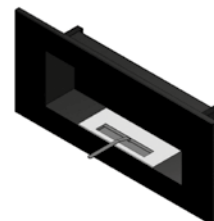
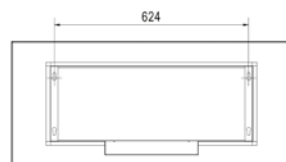
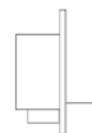
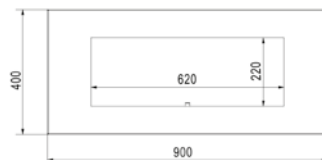
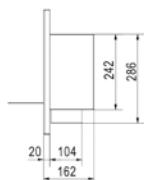

Weight: 12kg
 Material: black painted steel with various fascia options (see above)
 Option: glass protection screen



PEORIA

NEW

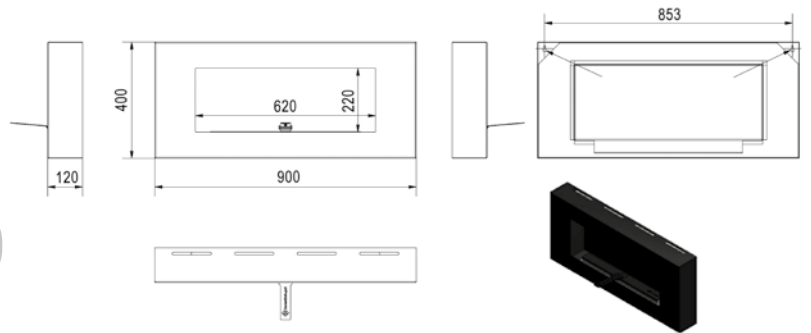

Weight: 15kg
Material: black painted steel
Option: glass protection screen

MARANA

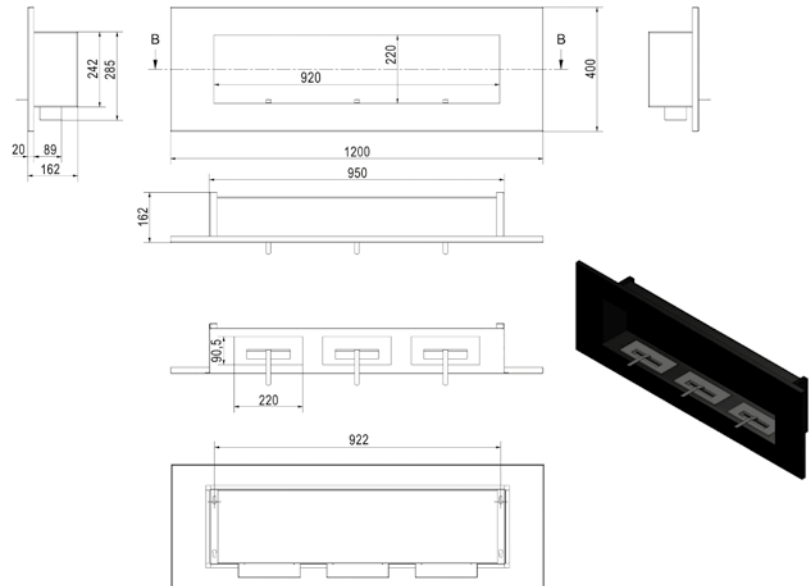

Weight: 15.5kg
Material: black painted steel
Option: glass protection screen

GILBERT

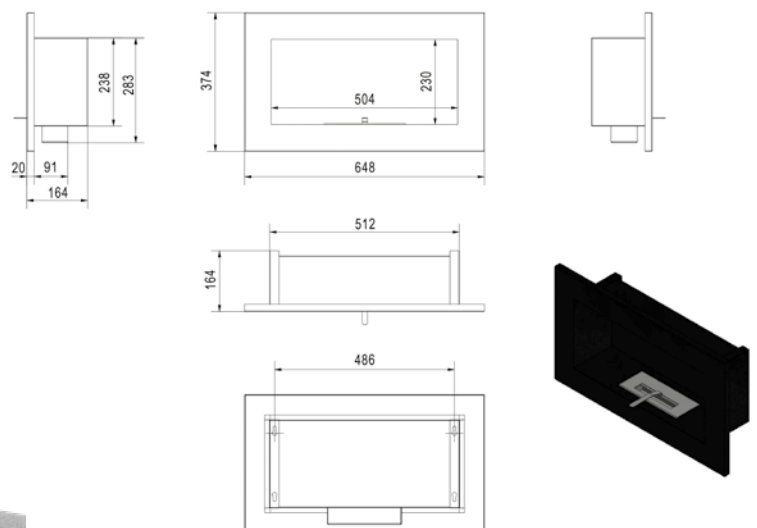

Weight: 4.4 - 6.6kg
Material: black painted steel with various fascia options (see above)
Option: glass protection screen

LILLIAN 1



Weight: 23kg
 Material: black painted steel with stainless fascia
 Optional: glass protection screen

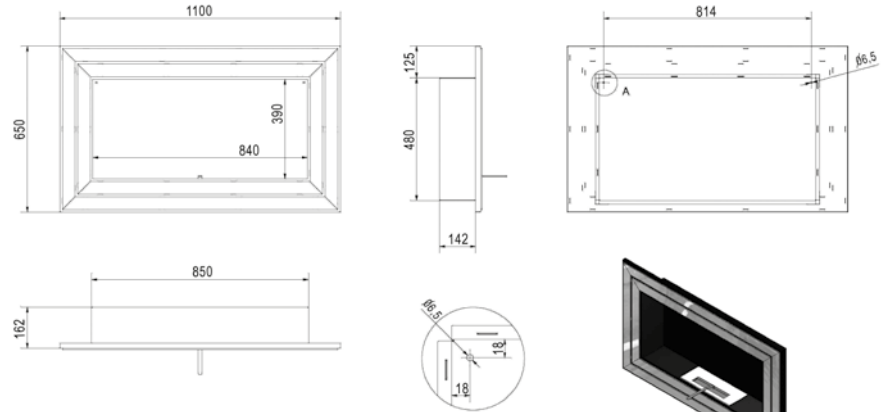

LILLIAN 2



Weight: 31kg
 Material: black painted steel with stainless fascia
 Optional: glass protection screen

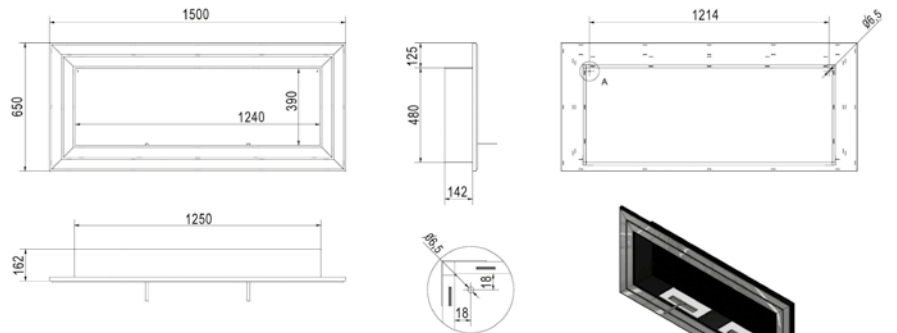

LILLIAN 3



Weight: 38kg
 Material: black painted steel with stainless fascia
 Optional: glass protection screen

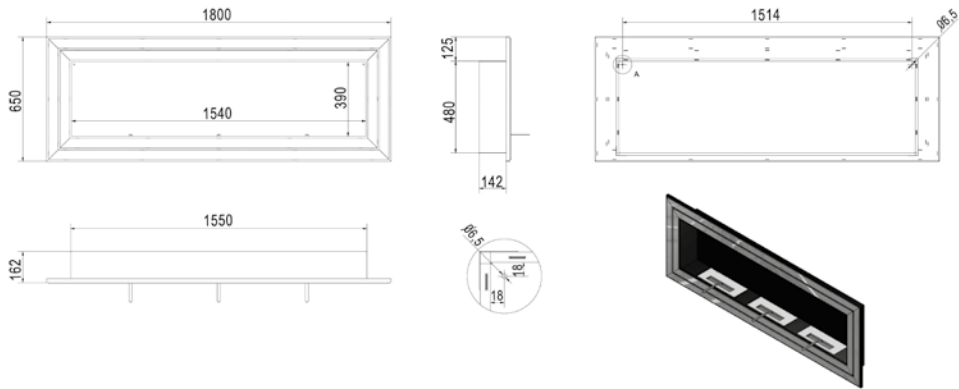

PIMA

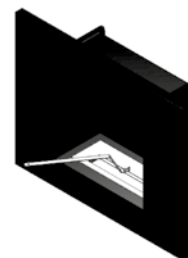
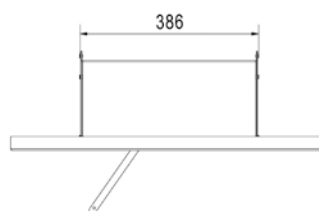
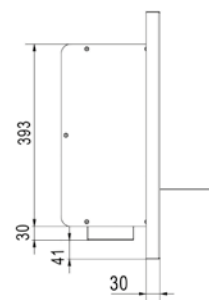
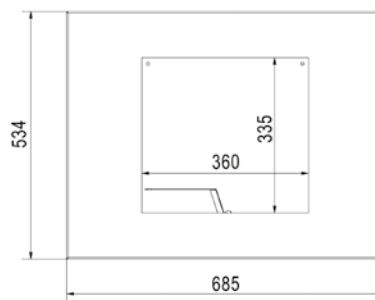
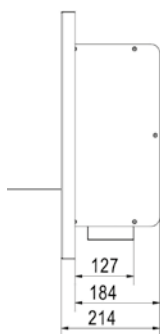

Weight: 10.9kg
Material: black painted steel
Option: glass protection screen



BURNER BOX SMALL



Weight: 1.2kg
Material: steel

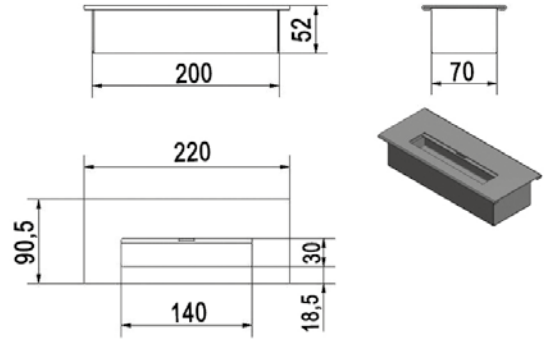

BURNER BOX MEDIUM



Weight: 2.7kg
Material: steel

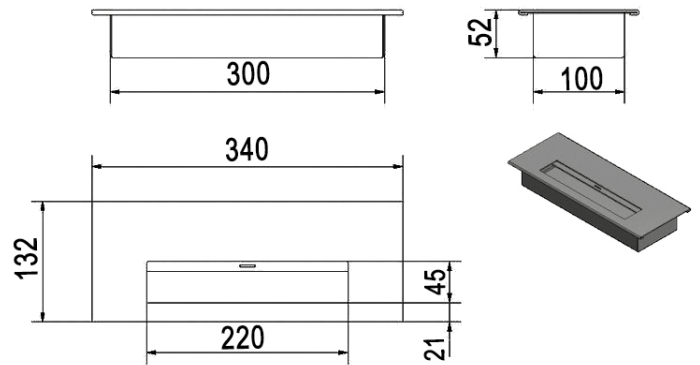

BURNER BOX LARGE



Weight: 3.8kg
Material: steel

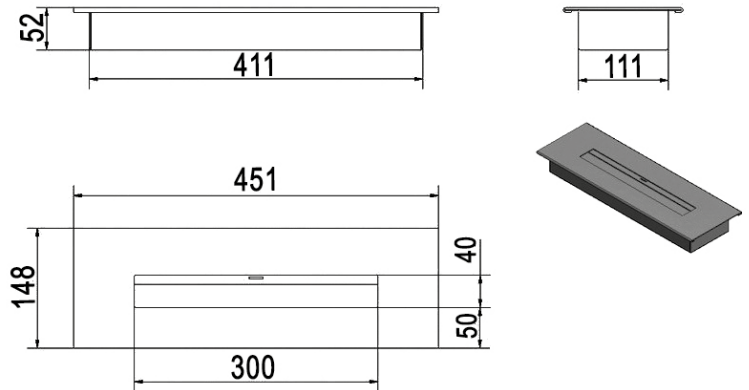

EASY-930

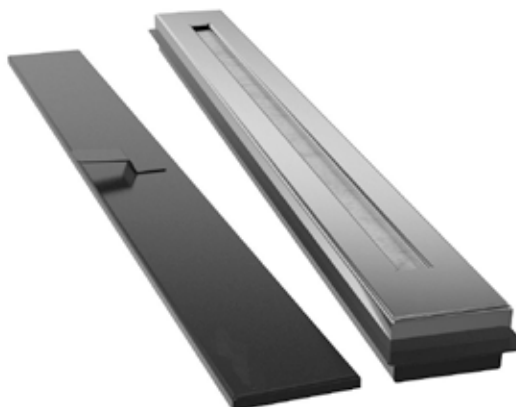

Weight: 7.5kg
Material: black painted steel
Option: pebble set

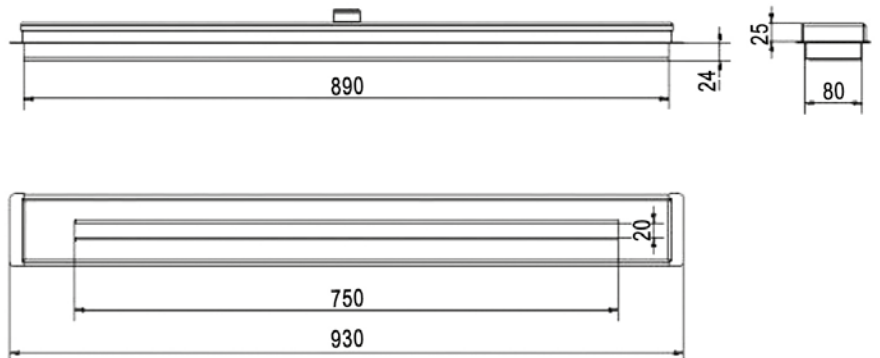



COLORADO

NEW



Weight: 4kg
Material: black painted steel, glass

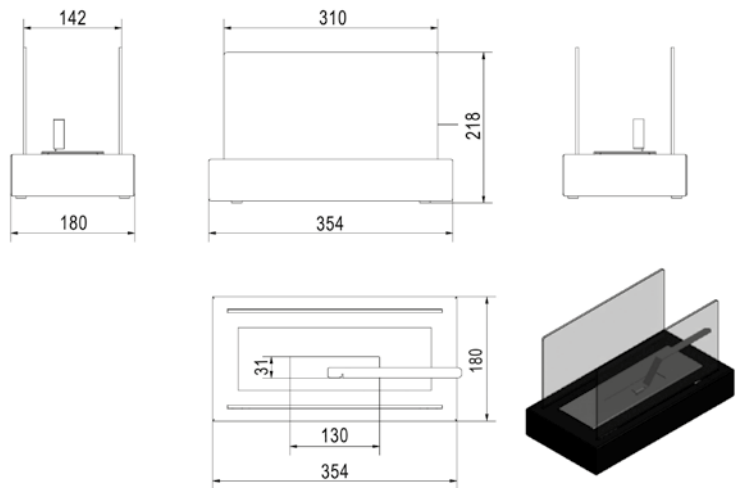

FLAGSTAFF



Weight: 15kg
Material: black painted steel

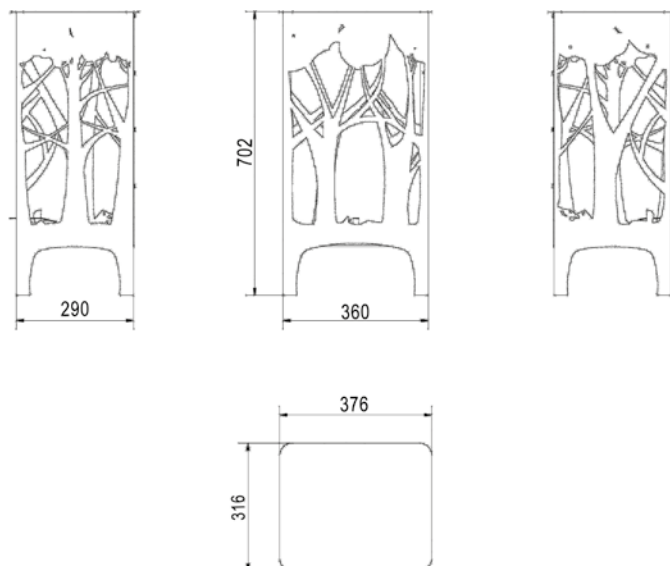

TUCSON (200)

NEW



Black

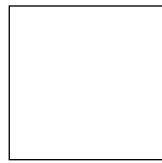

White

Weight: 4.3kg

Material: available in black or white steel with glass

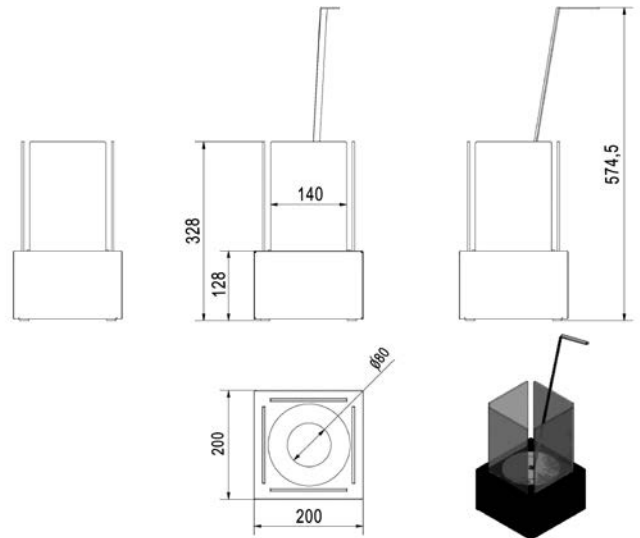

TUCSON (250)

NEW



Black

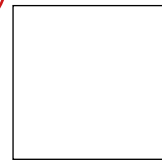

White

Weight: 5.2kg

Material: available in black or white steel with glass

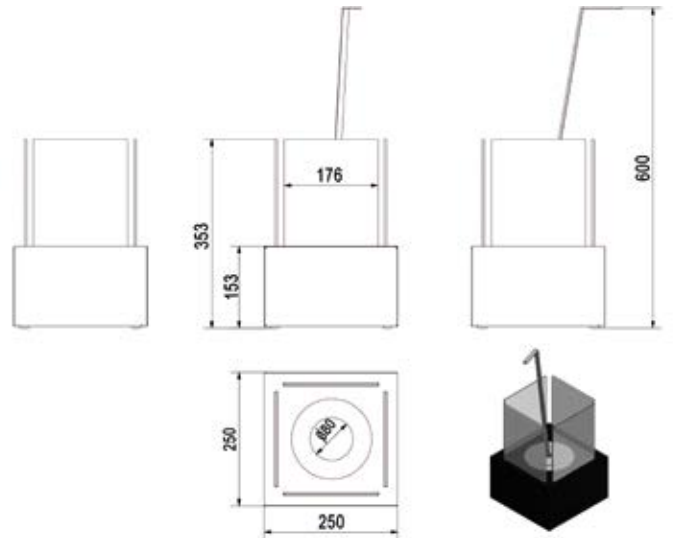

TUCSON (300)

NEW



White



Black

Weight: 5.6kg

Material: available in black or white steel with glass

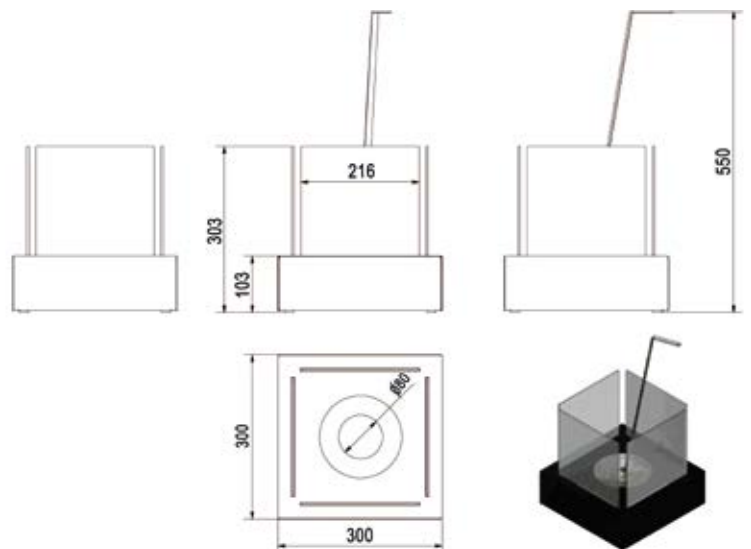

TUCSON (400)



Black

White

Weight: 10.7kg

Material: available in black or white steel with glass

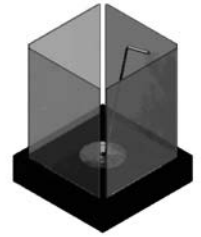
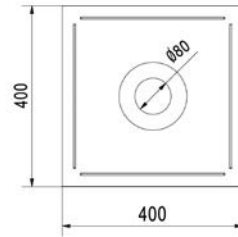
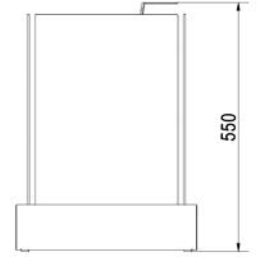
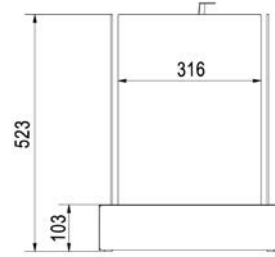
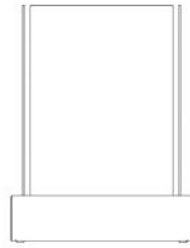

VIAL SMALL



Weight: 2kg
Material: black with glass

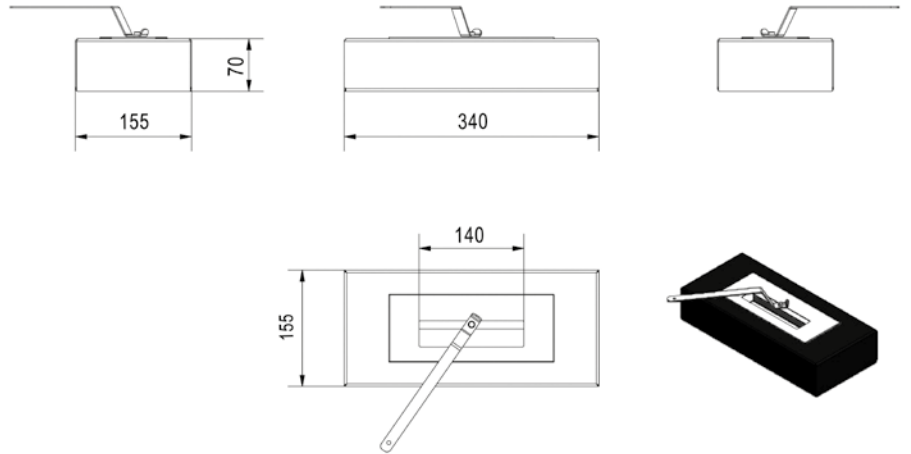

VIAL MEDIUM



Weight: 4kg
Material: black with glass

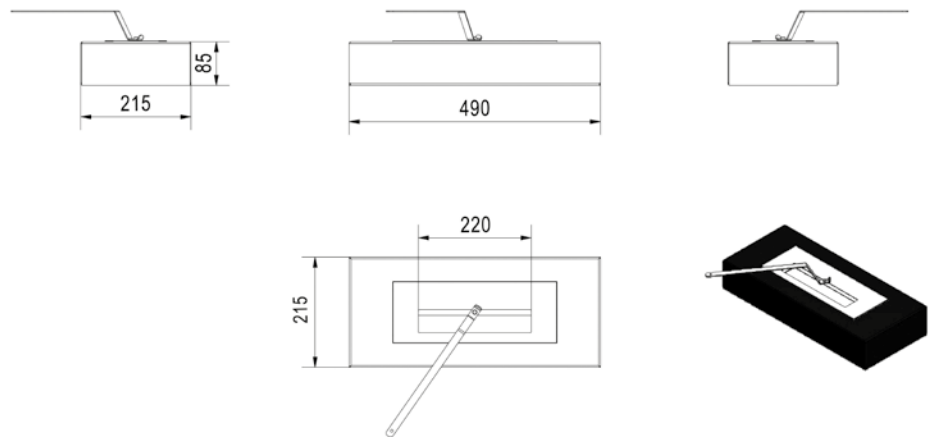

VIAL MAXIMUM



Weight: 7kg
Material: black with glass

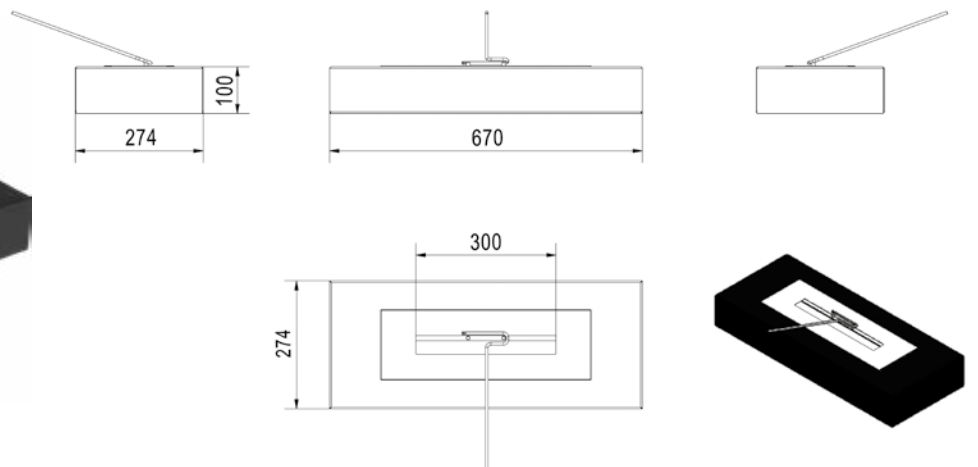

HOLBROOK LARGE

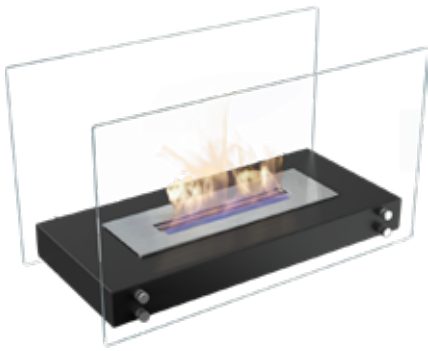

Weight: 17kg
Material: black with glass

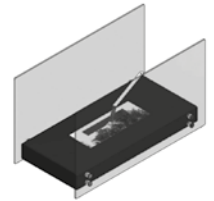
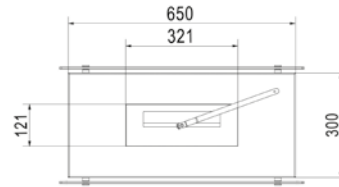
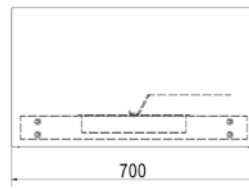
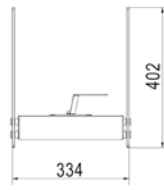

HOLBROOK MINI

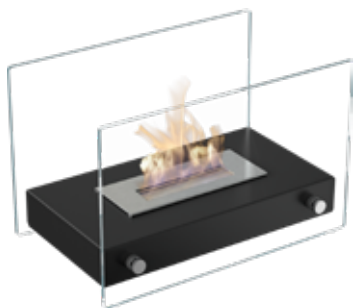

Weight: 7kg
Material: black with glass

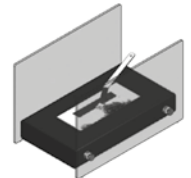
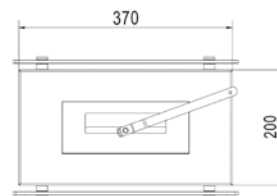
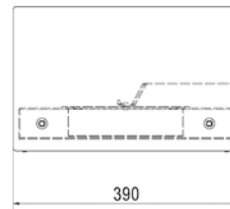
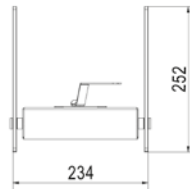

PAULDEN LARGE



Weight: 10.4kg
Material: black

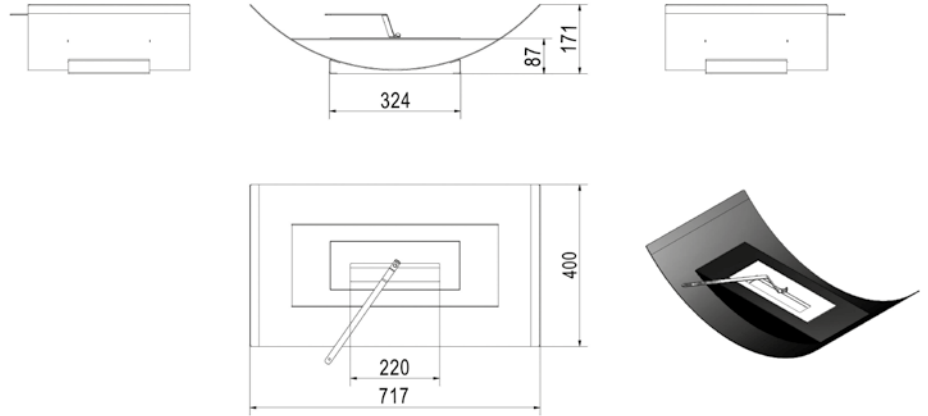

PAULDEN MINI



Weight: 4kg
Material: black

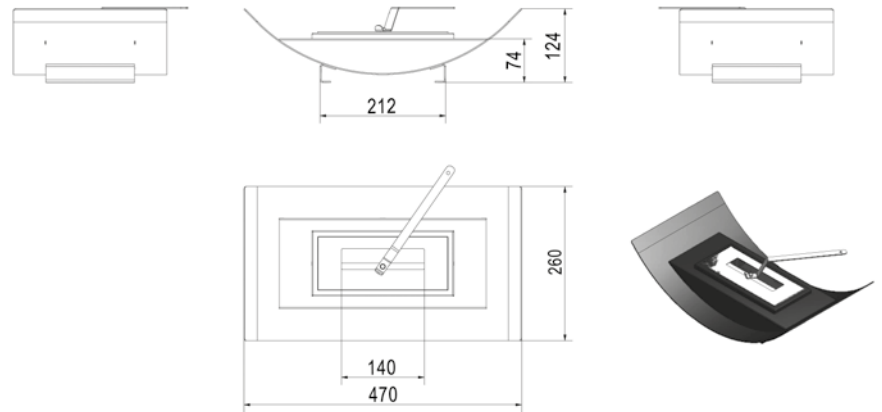

PHOENIX



Weight: 19kg
Material: black painted steel, glass

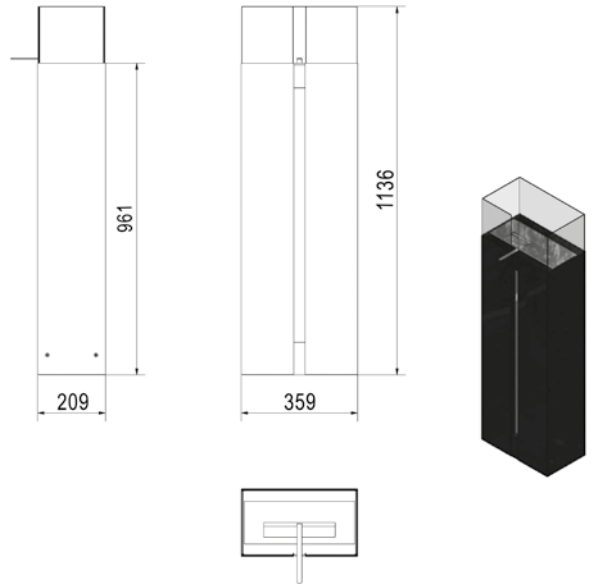

ORO



Weight: 48.5kg
Material: black or white MDF, painted steel
Optional: glass protection screen

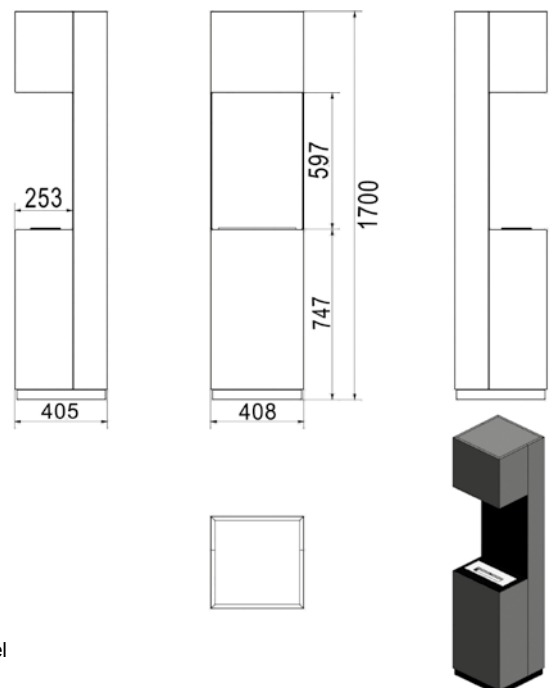



CVO FIRE



For additional details, technical specifications and prices call
Sales: Monday to Saturday, 9am to 6pm
or email: sales@cvo.co.uk

CVO FIRE is a brand of Spirit Fires Limited
4 Beaumont Square, Aycliffe Industrial Park
Newton Aycliffe, Co. Durham DL5 6XN

Call: 01325 301020
Email: sales@cvo.co.uk
Web: www.cvo.co.uk

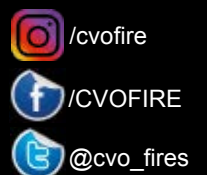

Bio Ethanol Fires



RETAIL PRICE LIST

SKU	Product Name	RRP (inc VAT)
P-LC183	RB100 (1020) Black Top Remote Control Bio Ethanol Burner [102x24x21.1cm] 240v Mains	4,549.00
P-LC133	RB100 (1020) Brushed Steel Top - Remote Control Bio Ethanol Burner [102x24x21.1cm] 240v Mains	4,299.00
P-LC184	RB120 (1220) Black Top Remote Control Bio Ethanol Burner [122x24x21.1cm] 240v Mains	5,249.00
P-LC134	RB120 (1220) Brushed Steel Top - Remote Control Bio Ethanol Burner [122x24x21.1cm] 240v Mains	4,999.00
P-LC185	RB150 (1520) Black Top Remote Control Bio Ethanol Burner [152x24x21.1cm] 240v Mains	5,999.00
P-LC135	RB150 (1520) Brushed Steel Top - Remote Control Bio Ethanol Burner [152x24x21.1cm] 240v Mains	5,749.00
P-LC186	RB180 (1820) Black Top Remote Control Bio Ethanol Burner [182x24x21.1cm] 240v Mains	6,749.00
P-LC136	RB180 (1820) Brushed Steel Top - Remote Control Bio Ethanol Burner [182x24x21.1cm] 240v Mains	6,499.00
P-LC189	RB230 (2300) Black Top Remote Control Bio Ethanol Burner [230x24x21.1cm] 240v Mains	7,999.00
P-LC201	RB230 (2300) Brushed Top Remote Control Bio Ethanol Burner [230x24x21.1cm] 240v Mains	7,749.00
P-LC182	RB66 (680) Black Top Remote Control Bio Ethanol Burner [68x24x21.1cm] 240v Mains	3,749.00
P-LC132	RB66 (680) Brushed Steel Top - Remote Control Bio Ethanol Burner [68x24x21.1cm] 240v Mains	3,499.00
P-LC187	RB82 (820) Black Top Remote Control Bio Ethanol Burner [82x24x21.1cm] 240v Mains	4,149.00
P-LC196	RB82 (820) Brushed Top Remote Control Bio Ethanol Burner [82x24x21.1cm] 240v Mains	3,899.00
X-GEL-005	12x 1L Bottles of Bio Ethanol Fuel	45.00
X-GEL-008	CVO1000 Bio Ethanol Ribbon Burner	1,399.00
P-CC372	CVO1000 Brushed Steel Enclosure - Rev 1	1,099.00
P-CC374	CVO1000 Brushed Steel Trim - Rev 1	399.00
P-CC326	CVO1000 Double Sided Brushed Steel Enclosure - Rev 1	1,499.00
P-CC506	CVO1000 Double Sided HT Black Enclosure - Rev 1	1,499.00
P-CC002	CVO1000 Double Sided Polished Steel Enclosure - Rev 1	1,799.00
P-CC399	CVO1000 HT Black Enclosure - Rev 1	999.00
P-CC403	CVO1000 PCS Black Trim - Rev 1	349.00
P-CC373	CVO1000 Polished Steel Enclosure - Rev 1	1,299.00
X-GEL-009	CVO600 Bio Ethanol Ribbon Burner	899.00
P-CC109	CVO600 Brushed Steel Enclosure - Rev 1	749.00
P-CC061	CVO600 Brushed Steel Trim - Rev 2	249.00
P-CC032	CVO600 Double Sided Brushed Steel Enclosure - Rev 0	1,249.00
P-CC031	CVO600 Double Sided HT Black Enclosure - Rev 0	1,149.00
P-CC022	CVO600 Double Sided Polished Steel Enclosure - Rev 0	1,449.00
P-CC020	CVO600 HT Black Enclosure - Rev 1	649.00
P-CC060	CVO600 PCS Black Trim - Rev 2	249.00
P-CC311	CVO600 Polished Steel Enclosure - Rev 1	949.00

SKU	Product Name	RRP (inc VAT)
P-CC189	Fire Grate (HT Black) for RB660 Remote Bio Burner	789.00
X-GEL-011	Fire Vessel Bio Ethanol in Aluminium Cast Metal	2,649.00
X-GEL-010	Fire Vessel Bio Ethanol in Bronze Cast Metal	2,649.00
X-GEL-016	Francesca Bio Ethanol Fireplace with Brushed Steel Fascia	658.95
X-GEL-038	Francesca Bio Ethanol Fireplace with Satin Black Fascia	658.95
X-GEL-130	Francesca Bio Ethanol Fireplace without Fascia	558.95
P-KC031	Francesca Bio Ethanol Pebbles Set [Fawn & Grey Mixed]	49.99
P-CC030	Large Bio Burner [LC107] Brushed Steel Enclosure - Rev 1	699.00
P-CC028	Large Bio Burner [LC107] HT Black Enclosure - Rev 1	499.00
P-CC201	Large Bio Burner [LC107] Polished Enclosure - Rev 1	749.00
X-GEL-083	Large Oval Bio Ethanol Fire Bowl in Bronze Cast Metal & Fawn Stone Set (int) & Mixed Pebble Set (ext)	4,210.00
P-LC137	Lighter for Bio-Ethanol Fireplace	4.99
P-CC511	RB1000 Remote Bio Fire Brushed Steel Enclosure [1300x500x320] - Rev 2	1,799.00
P-CC537	RB1000 Remote Bio Fire Double Sided Brushed Steel Enclosure - Rev 1	2,599.00
P-CC536	RB1000 Remote Bio Fire Double Sided HT Black Enclosure - Rev 1	2,799.00
P-CC538	RB1000 Remote Bio Fire Double Sided Polished Steel Enclosure - Rev 1	3,049.00
P-CC512	RB1000 Remote Bio Fire HT Black Enclosure [1300x500x320] - Rev 2	1,999.00
P-CC514	RB1000 Remote Bio Fire Polished Steel Enclosure [1300x500x320] - Rev 2	2,249.00
P-CC163	RB1200 Remote Bio Double Sided Brushed Steel Enclosure - Rev 1	2,799.00
P-CC203	RB1200 Remote Bio Double Sided HT Black Enclosure - Rev 1	2,999.00
P-CC173	RB1200 Remote Bio Double Sided Polished Steel Enclosure - Rev 1	3,249.00
P-CC509	RB1200 Remote Bio Fire Brushed Steel Enclosure [1500x500x320] - Rev 3	1,999.00
P-CC510	RB1200 Remote Bio Fire HT Black Enclosure [1500x500x320] - Rev 3	2,199.00
P-CC521	RB1200 Remote Bio Fire Polished Steel Enclosure [1500x500x320] - Rev 3	2,449.00
P-CC507	RB1500 Remote Bio Fire Brushed Steel Enclosure [1800x500x320] - Rev 3	2,199.00
P-CC540	RB1500 Remote Bio Fire Double Sided Brushed Steel Enclosure - Rev 1	2,999.00
P-CC539	RB1500 Remote Bio Fire Double Sided HT Black Enclosure - Rev 1	3,199.00
P-CC541	RB1500 Remote Bio Fire Double Sided Polished Steel Enclosure - Rev 1	3,449.00
P-CC508	RB1500 Remote Bio Fire HT Black Enclosure [1800x500x320] - Rev 3	2,399.00
P-CC520	RB1500 Remote Bio Fire Polished Steel Enclosure [1800x500x320] - Rev 3	2,649.00
P-CC063	RB1800 Remote Bio Brushed Steel Enclosure [2100x500x320] - Rev 1	2,399.00
P-CC543	RB1800 Remote Bio Fire Double Sided Brushed Steel Enclosure - Rev 1	3,199.00
P-CC542	RB1800 Remote Bio Fire Double Sided HT Black Enclosure - Rev 1	3,399.00
P-CC544	RB1800 Remote Bio Fire Double Sided Polished Steel Enclosure - Rev 1	3,649.00
P-CC062	RB1800 Remote Bio HT Black Steel Enclosure [2100x500x320] - Rev 1	2,599.00
P-CC079	RB1800 Remote Bio Polished Steel Enclosure [2100x500x320] - Rev 1	2,849.00
P-CC546	RB2300 Remote Bio Fire Brushed Steel Enclosure [2600 x 500 x 320mm] - Rev 1	2,799.99
P-CC545	RB2300 Remote Bio Fire HT Black Enclosure [2600 x 500 x 320mm] - Rev 1	2,999.99
P-CC547	RB2300 Remote Bio Fire Polished Steel Enclosure [2600 x 500 x 320mm] - Rev 1	3,249.99

SKU	Product Name	RRP (inc VAT)
P-CC517	RB660 Remote Bio Fire Brushed Steel Enclosure [1000x500x320] - Rev 0	1,699.00
P-CC534	RB660 Remote Bio Fire Double Sided Brushed Steel Enclosure - Rev 1	2,499.00
P-CC533	RB660 Remote Bio Fire Double Sided HT Black Enclosure - Rev 1	2,699.00
P-CC535	RB660 Remote Bio Fire Double Sided Polished Steel Enclosure - Rev 1	2,949.00
P-CC518	RB660 Remote Bio Fire HT Black Enclosure [1000x500x320] - Rev 0	1,899.00
P-CC519	RB660 Remote Bio Fire Polished Steel Enclosure [1000x500x320] - Rev 0	2,149.00
P-CC531	RB820 Remote Bio Fire Brushed Steel Enclosure [1120x500x320] - Rev 1	1,699.00
P-CC528	RB820 Remote Bio Fire Double Sided Brushed Steel Enclosure - Rev 1	2,499.00
P-CC527	RB820 Remote Bio Fire Double Sided HT Black Enclosure - Rev 1	2,699.00
P-CC529	RB820 Remote Bio Fire Double Sided Polished Steel Enclosure - Rev 1	2,949.00
P-CC530	RB820 Remote Bio Fire HT Black Enclosure [1120x500x320] - Rev 1	1,899.00
P-CC532	RB820 Remote Bio Fire Polished Steel Enclosure [1120x500x320] - Rev 1	2,149.00
X-GEL-039	Small Oval Bio Ethanol Fire Bowl in Aluminium Cast Metal & Brown Stone Set	4,699.00
X-GEL-141	Small Oval Bio Ethanol Fire Bowl in Aluminium Cast Metal & Grey Stone Set	4,699.00
X-GEL-027	Small Oval Bio Ethanol Fire Bowl in Bronze Cast Metal & Brown Stone Set	4,799.00
X-GEL-140	Small Oval Bio Ethanol Fire Bowl in Bronze Cast Metal & Grey Stone Set	4,799.00
X-GEL-006	Small Oval Bio Ethanol Fire Bowl in Cast White Stone & Brown Stone Set	899.00
X-GEL-142	Small Oval Bio Ethanol Fire Bowl in Matt Black Cast Stone & Grey Stone Set	974.00
X-GEL-007	Small Oval Bio Ethanol Fire Bowl in Matt Black Cast Stone & White Stone Set	974.00
X-GEL-138	Small Oval Bio Ethanol Fire Bowl in White Cast Stone & Grey Stone Set	899.00
X-GEL-017	Small Oval Bio Ethanol Fire Bowl in White Cast Stone & White Stone Set	899.00
P-LC005	Avondale - Black	549.00
P-LC084	Avondale - Brushed	599.00
P-LC107	Bio-Ethanol Burner Box - Large	185.00
P-LC106	Bio-Ethanol Burner Box - Medium	175.00
P-LC105	Bio-Ethanol Burner Box - Small	165.00
P-LC120	Carefree - Black	305.00
P-LC079	Casa Grande - Black	499.99
P-LC075	Catalina - Black	549.00
P-LC153	Colorado	225.00
P-LC112	Dilkon - Black	595.00
P-LC089	Douglas - Black	379.99
P-LC093	Douglas - Brushed	379.99
P-LC129	Douglas - Horizontal	379.99
P-LC125	Douglas Qube - Black	379.99
P-LC001	Easy - 930 Long Bio Burner (930mm)	999.99
P-LC096	Flagstaff	269.00
P-LC142	Gilbert - Black	249.99
P-LC143	Gilbert - Brushed	249.99

SKU	Product Name	RRP (inc VAT)
P-LC127	Gilbert - Horizontal	249.99
P-LC115	Gilbert - Vertical	249.99
P-LC097	Gilbert Qube - Brushed & Black	249.99
P-LC099	Holbrook Large - Black	299.99
P-LC176	Holbrook Small - Black	279.99
P-LC139	Lillian A - 1100mm x 650mm	757.99
P-LC140	Lillian B - 1500mm x 650mm	884.50
P-LC141	Lillian C - 1800mm x 650mm	999.75
P-LC131	Marana	759.99
P-LC168	Optional Glass Panel - Avondale	188.49
P-LC172	Optional Glass Panel - Carefree	165.00
P-LC166	Optional Glass Panel - Catalina	188.49
P-LC170	Optional Glass Panel - Dikon	188.49
P-LC171	Optional Glass Panel - Douglas	179.99
P-LC173	Optional Glass Panel - Gilbert	165.00
P-LC192	Optional Glass Panel - Lillian A	110.00
P-LC193	Optional Glass Panel - Lillian B	132.49
P-LC194	Optional Glass Panel - Lillian C	179.49
P-LC190	Optional Glass Panel - Marana	165.00
P-LC180	Optional Glass Panel - Oro	233.25
P-LC191	Optional Glass Panel - Peoria	71.50
P-LC174	Optional Glass Panel - Pima	168.95
P-LC169	Optional Glass Panel - Wellton	159.00
P-LC072	Oro - Black	749.99
P-LC146	Oro - White	595.99
P-LC102	Paulden - Black	249.99
P-LC177	Paulden Large - Black	319.99
P-LC144	Peoria	449.99
P-LC145	Phoenix - Black	399.99
P-LC147	Pima - Black	489.00
P-LC155	Tucson 200 - Black	199.99
P-LC154	Tucson 200 - White	199.99
P-LC158	Tucson 250 - Black	215.00
P-LC157	Tucson 250 - White	215.00
P-LC161	Tucson 300 - Black	225.00
P-LC160	Tucson 300 - White	225.00
P-LC164	Tucson 400 - Black	239.00
P-LC163	Tucson 400 - White	239.00
P-LC122	Vial [Max]	225.00

SKU	Product Name	RRP (inc VAT)
P-LC100	Vial [Med] - Black	215.00
P-LC121	Vial [Min]	199.99
P-LC085	Wellton - Black	656.00

Note: Only the Natural Gas version is shown on the price list however fires are also available for use with LPG/Propane. To calculate the price of the LPG/Propane version add £44. Prices valid for 30 days from published date below and include VAT @ 20%. For the latest offers and to place your order **Call Sales on 01325-301020, Monday to Saturday 9am to 6pm**. For images, videos and technical specifications visit our web site at www.cvo.co.uk. Fires are available for all installation types and fuel types – gas, wood, bioethanol and electric. To receive information on our other ranges, call sales. Trade accounts are set up upon application.

Spirit Fires Ltd, Unit 4, Beaumont Square, Durham Way South, Newton Aycliffe, County Durham, DL5 6XN