



Owner's Manual

DT7

Treadmill Desk/Bike Desk

Congratulations on Choosing LifeSpan Workplace Line of Products!

These products give you the opportunity to remain productive while taking care of yourself as you integrate movement with normally sedentary tasks.

The average American now spends eleven hours, five days a week, sitting, and burns one-hundred fewer calories each day than they did a few decades ago. Sitting for long periods slows your metabolism, reduces calories burned, and increases your risk for heart disease and diabetes.

Whether you plan on placing this product in a TV room, replace your desk at home or are adding another workspace in the office, LifeSpan Workplace™ products are a great way to add movement to an otherwise sedentary activity.

Before you assemble or operate your product, please read this manual thoroughly. Important information, including safety precautions, ongoing product maintenance, assembly instructions, and information on proper operation are included.

If you need to contact LifeSpan customer service, visit our website at www.LifeSpanFitness.com and select customer service. Complete the information requested and we will respond to your inquiry within one business day. In the United States and Canada you can also call (877) 654-3837 and choose option 4.

Neither LifeSpan nor its representatives can accept responsibility for any damages or injury incurred as a result of information presented in this manual except under the terms of the product warranty.

Getting Started	6
Warranty	
Safety & Usage	
Safety Tips	
Children and Pets	
Proper Grounding, Power Cord Options	
Assembly	12
Exploded View & Hardware	
Assembly Instructions	
DT7 Desk & Electric Treadmill Assembly	28
DT7 Desk & Electric Bike Assembly	29
Moving Your Treadmill Desk	30
Treadmill Desk Operations	31
Specifications	
Setting the Clock	
Starting the Treadmill Desk	
Console Buttons Overview	
Preset Button & Innovative Features	
Troubleshooting	
Personal Settings	
Display Details	
Bike Desk Operations	43
Specifications	
Setting the Clock	
Starting the Bike Desk	
Console Buttons Overview	
Innovative Features	
Troubleshooting	
Personal Settings	
Display Details	

Getting Started

Warranty

Your LifeSpan treadmill/bike desk comes with the following limited warranty valid in North America. If you are outside of this area contact your local authorized LifeSpan dealer.

Desk Frame & Parts	2 Years
Labor	1 Year

LifeSpan warrants the equipment it manufactures is free from defects in materials and workmanship under normal use and services. The periods above are based on the date of purchase. During these periods, LifeSpan will repair or replace any defective part. Free labor is included on all parts that are not normally assembled or replaced by the customer within the labor period.

If within the time frames specified above, any part fails to operate properly, login to our website at www.LifeSpanFitness.com, click on "Customer Service" and complete the form to request assistance or call 877.654.3837 option 4 for a Customer Service Agent (please note that certain kinds of service should only be performed by a qualified service technician).

LifeSpan reserves the right to make changes and improvements to our products without incurring any obligations to similarly alter any product purchased. In order to insure our product warranty and to ensure the safe and efficient operation of your LifeSpan product, only authorized parts can be used. The warranty is void if any parts other than those provided by LifeSpan are used.

Exclusions and Limitations:

- This warranty does not apply to any defects caused by negligence, misuse, improper assembly, or maintenance, accident, or "act of God."
- This warranty does not apply to discoloration of paints or plastics.
- LifeSpan shall not be responsible for incidental or consequential damages.
- This warranty is non-transferable from the original owner.

Safety & Usage

When using active workstations, basic precautions should always be followed, including:

- Never drop or insert any object into any opening. If an object falls into an opening, turn the power off and unplug the power cord from the outlet. Remove the object or call customer service at 877.654.3837 option 4.
- Never operate this treadmill if it has been damaged or partially submerged in water.
- To reduce the risk of electric shock, unplug the treadmill and desk from the wall outlet when not in use, before performing any maintenance, or before moving the treadmill and desk.
- Do not use outdoors or in areas of high humidity or extreme temperature changes.
- Do not operate where aerosol spray products are being used or where oxygen is being administered.
- Never place the power cords under carpeting or place any object on top of the cord, this may pinch or damage the cord causing fire damage or personal injury.
- Use this product for its intended use as described in this Owner's Manual. Do not use attachments that are not recommended by LifeSpan.
- Do not leave your treadmill running while not in use.
- A complete visual inspection and test of the features and functions of the assembled desk need to be made prior to use.
- Keep the area within the entire lift range of the desk clear of any obstructions to prevent personal or property damage. A minimum distance of 1 inch or 25 mm above, below and around the desk is recommended.
- Do not use the product beyond its intended purpose as office furniture.
- Do not use the product with defective or malfunctioning safety and protection devices .
- Do not make unapproved changes to the product with regard to its construction and implementation.
- Do not exceed product maximum loads specified in this manual.

Getting Started

Safety Tips While in Use

- Always consult a physician before beginning an exercise program.
- If you experience chest pains, nausea, dizziness or shortness of breath, stop exercising immediately and consult your physician before continuing. Do not wear clothing or jewelry that might catch on any part of the treadmill.
- Wear shoes with high traction rubber soles. Do not wear shoes with heels, leather soles, cleats or spikes.
- Do not walk backwards on the treadmill, always face forward.
- Allow the walking belt to fully stop prior to getting off the treadmill.
- Make sure the area behind the treadmill remains completely clear during use. A minimum of 3 feet (1m) of clearance is required for safety reasons. There should be a minimum of 2 ft. (.6 m) on at least one side of the treadmill.

Safety Clearance

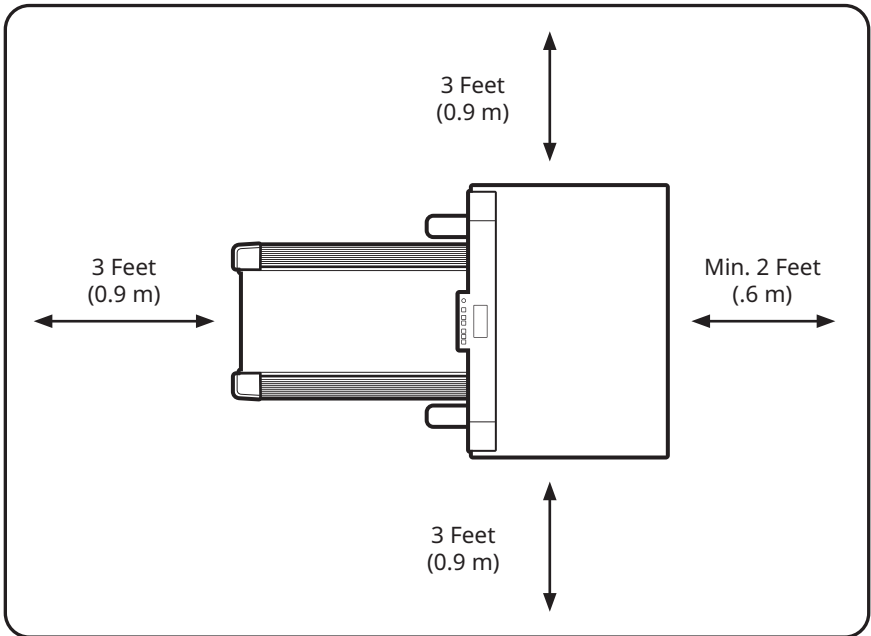

Children and Pets

- Keep children from playing on your treadmill at all times.
- When in use children and pets should be kept at least 10 feet (3m) away.
- Cleaning and user maintenance shall not be made by children without supervision.

Note: Read all instructions and save for future reference.

Getting Started

Proper Grounding

LifeSpan equipment must be grounded. Improper connection of the equipment's grounding conductor can result in the risk of electric shock. Check with a qualified electrician or service person if you are in doubt as to whether the outlet is properly grounded. Do not modify the plug provided or use a ground plug adapter to adapt to a non-grounded outlet. If the plug will not fit in the outlet, have the proper outlet installed by a qualified electrician.

Power Cord Options

This standing desk should only be used with the proper power cord and power outlet. Several power cord options (shown below) are available from LifeSpan. We do our best do include the correct power cord with the standing desk for your area. In the event that the correct power cord is not included in the packaging please contact your local distributor.

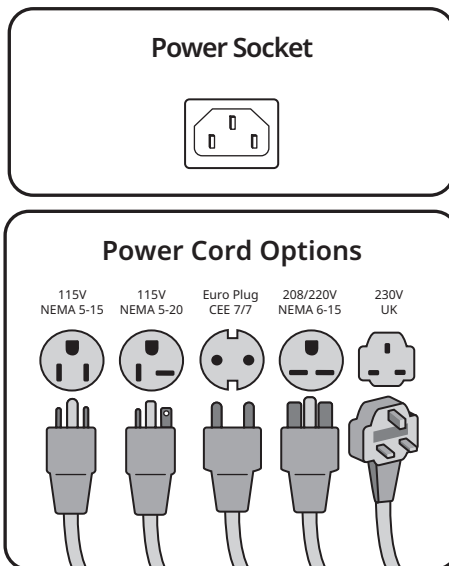

Do not use extension cords between the standing desk and power outlet.

Desk Assembly

Exploded View

At LifeSpan we strive to make our equipment easy to assemble and use.

Prior to starting the assembly process, take all the parts out of the box, remove plastic bags, and lay everything out on the floor to become familiar with the components.

Since your desk is a heavy piece of equipment, it is recommended that you use two people during assembly and follow these assembly instructions to reduce any problems that may occur.

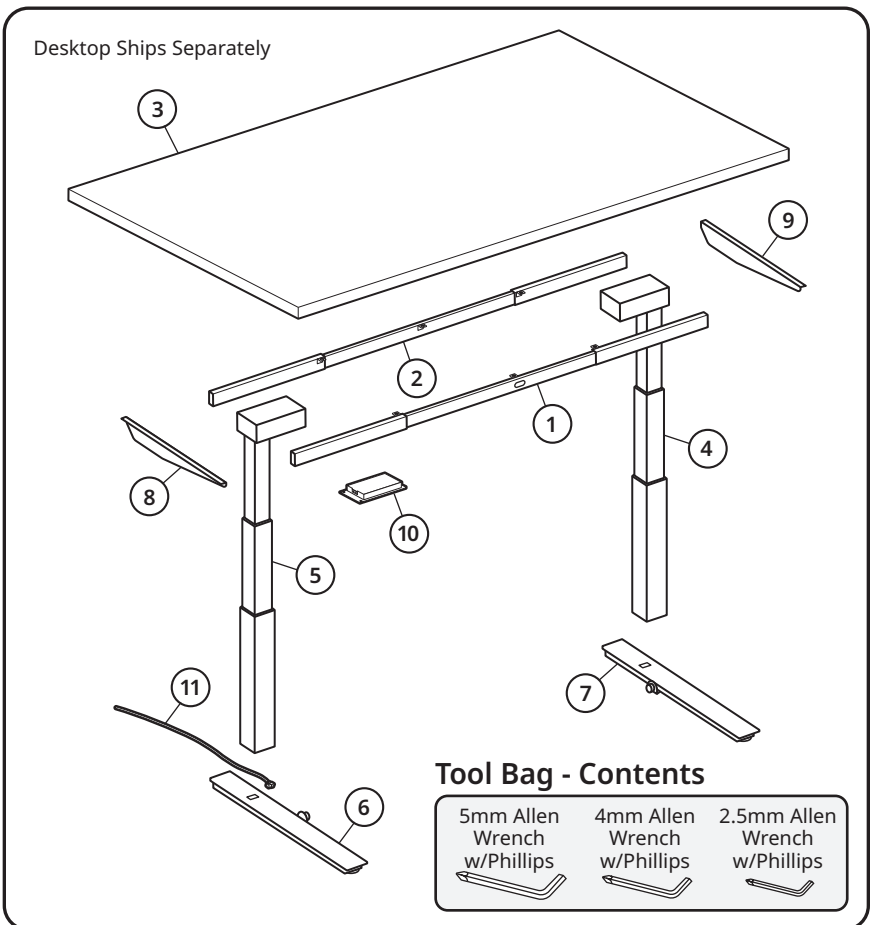





Hardware Included

Item#	Part Description
1	Front Reinforcement Frame
2	Back Reinforcement Frame
3	Desktop
4	Right Motorized Leg
5	Left Motorized Leg
6	Left Base Foot
7	Right Base Foot

Item#	Part Description
8	Left Desk Support Bracket
9	Right Desk Support Bracket
10	Electronics Control Box
11	Power Cord
12	Height Adjust Cable Adapter

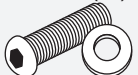
Hardware Bag Contents

Bag #	Item#	Qty.	Part Description
1	13	6	M8x12L Screws/Washers
2	14	8	M8x55L Bolts/Washers
3	15	6	M6x15L Screws/Washers
4	16	8	M8x35L Screws/Washers
4	17	6	M6x15L Screws/Washers
5	18	3	M4x 10L Screws/Washers
9	19	4	Cable Ties

<p>M8x12L (x6)</p>  <p>STEP 1 BAG</p>	<p>M8x55L (x8)</p>  <p>STEP 2 BAG</p>	<p>M6x15L (x6)</p>  <p>STEP 3 BAG</p>	<p>M8x35L (x8) M6x15L (x6)</p>  <p>STEP 4 BAG</p>
<p>M4x10L (x3)</p>  <p>STEP 5 BAG</p>	<p>Cable Ties (x4)</p>  <p>STEP 9 BAG</p>		

Pre-Installed Hardware (not shown)

Item#	Qty.	Hardware Description
21	4	M8x 8L Set Screws

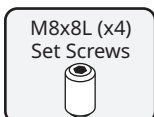

Table corresponds to the diagram on the left

Desk Assembly

Step 1: Attach Right and Left Side Desk Support Brackets

LOCATE BAG LABELED STEP 1

Contents: 6 each M8x12L Screws with Washers

- Attach the Left Desk Support Bracket(8) to the Left Motorized Leg(5). Each will have an “LLL” sticker attached for easy identification.
- Stand the leg on the motor side as shown in the illustration and align the bracket.
- Locate the screws for Step 1 and hand tighten the bracket to the leg. Then securely tighten with the included tool.
- Repeat for the Right Desk Support Bracket(9) and Right Motorized Leg(4).

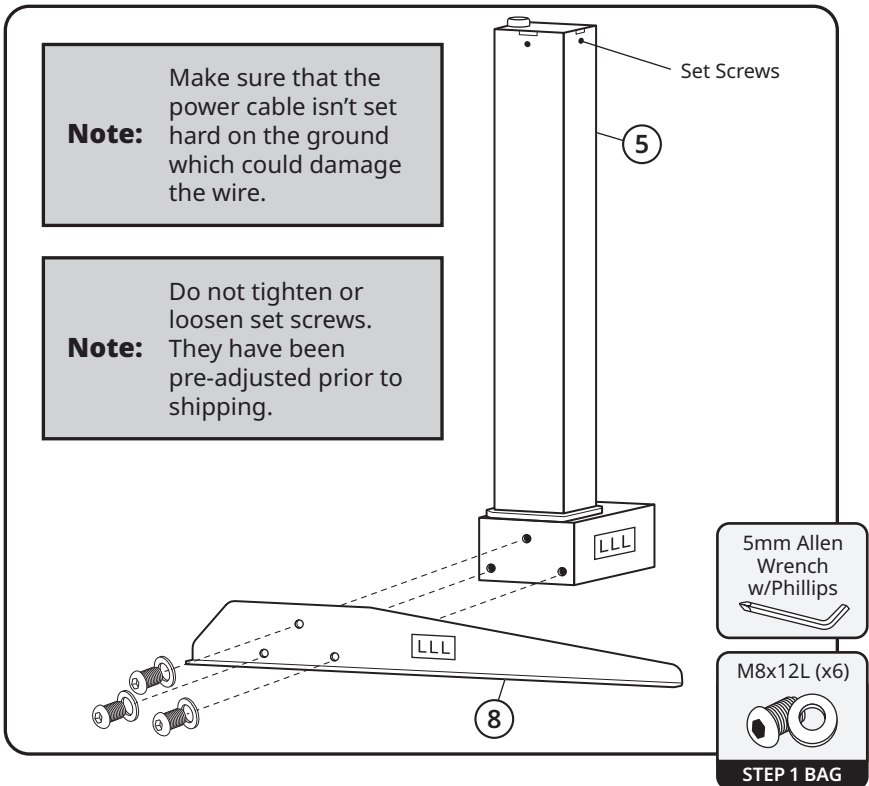

Step 2: Attach Base Foot

LOCATE BAG LABELED STEP 2

Contents: 8 each M8x55L Bolts with Washers

- A. Insert four M8x55L Bolts and Washers through the Left Base Foot (6).
- B. Align Left Base Foot(6) labelled "LLL" with the Left Motorized Leg(5) and connect the wires.
- C. Push ALL extra wiring into the Left Base Foot(6).

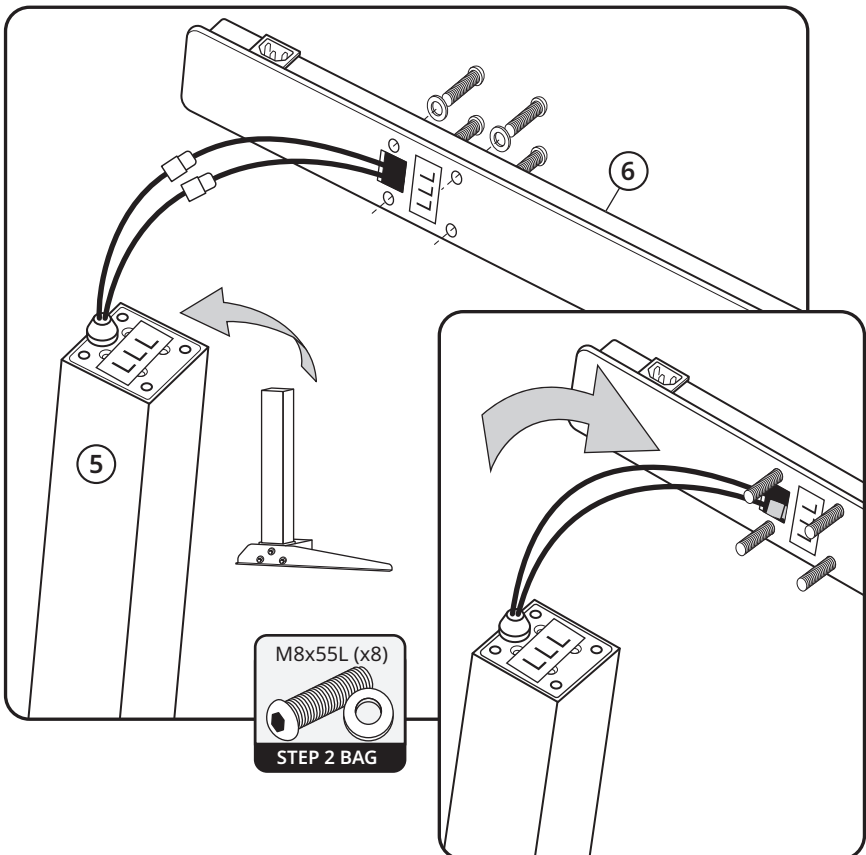

Desk Assembly

Step 2: Attach Base Foot (Continued)

- D. Connect the Left Base Foot(6) to the Left Motorized Leg(5) with the four installed M8x55L Bolts with Washers(14).
- E. Fully tighten each of the four bolts.
- F. Tip the left post on its side.
- G. Repeat the same procedure on the right side.

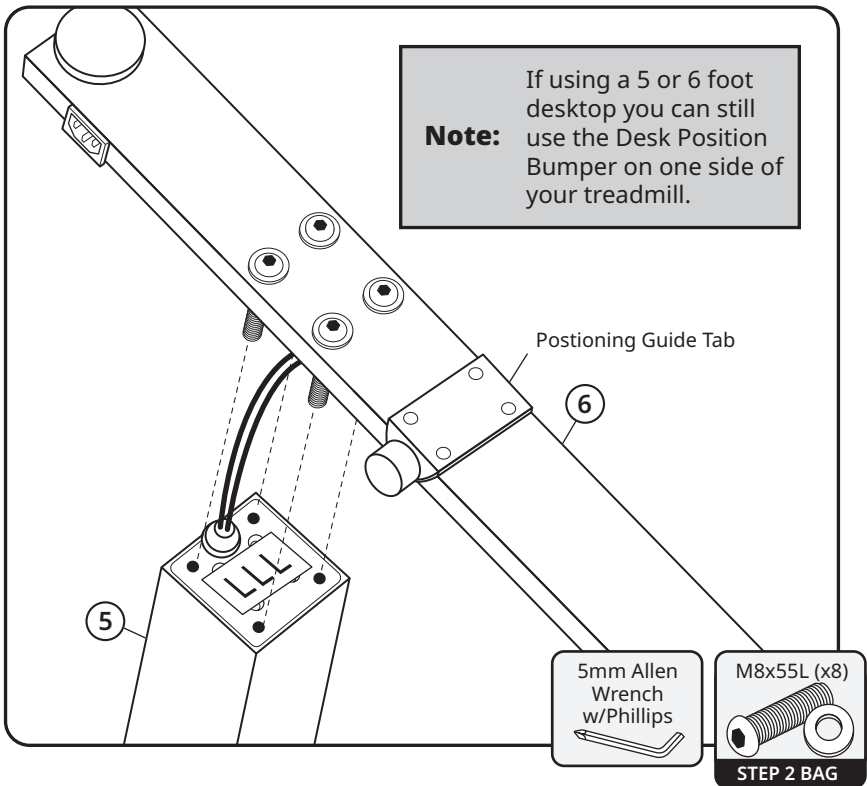

Step 3: Attach Desktop to Posts

LOCATE BAG LABELED STEP 3

Contents: 6 each M6x15L Screws

- A. Place the right post on top of the Desktop(3) as shown in the illustration. Tighten each of the three M6x15L Screws and Washers(15) as shown.
- B. Repeat on the left side.

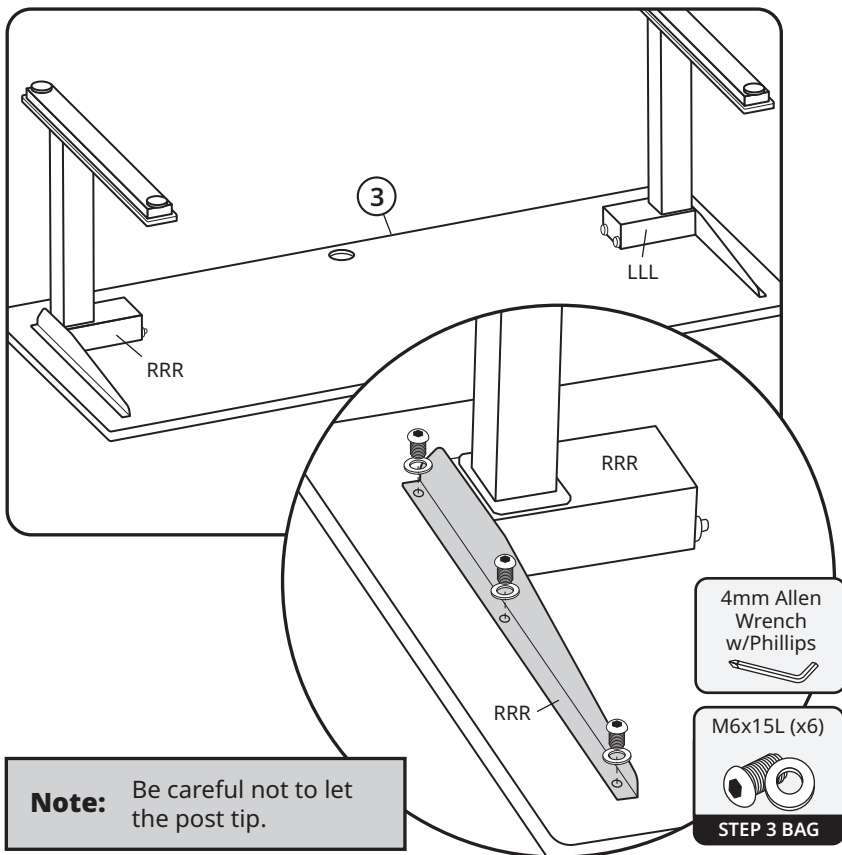

Desk Assembly

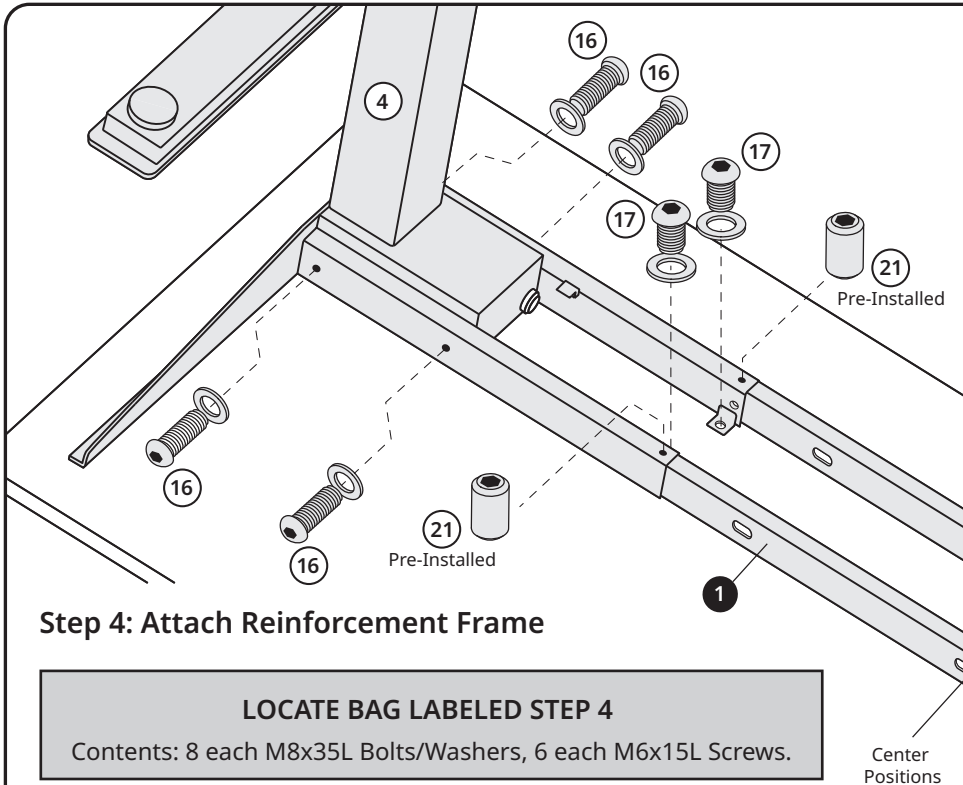

Step 4: Attach Reinforcement Frame

LOCATE BAG LABELED STEP 4

Contents: 8 each M8x35L Bolts/Washers, 6 each M6x15L Screws.

- Locate the Front Reinforcement Frame labelled (1) and the Back Reinforcement Frame labeled (2). Place these frames on Desktop with screw tabs down and facing each other as shown.
- Extend Front and Back reinforcement Frames(1, 2) to align all mounting holes with Desktop(3) and Motorized Legs(4, 5).
- Loosely install the eight M8x35L(16) bolts through the Reinforcement Frames (1,2) and into the Motorized Legs (4,5).
- Tighten all eight M8x35L(16) bolts.

5mm Allen
Wrench
w/Phillips



M8x8L (x4)
Set Screws



M8x35L (x8)

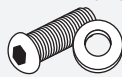

M6x15L (x6)



4mm Allen
Wrench
w/Phillips



STEP 4 BAG

72" desktop shown for clarity of frame components. When mounting the frame to smaller desktop sizes, the front and back reinforcement frame pieces slide and compress into shorter lengths.

- E. Using the six M6x15L Screws(17) attach both Reinforcement Frames to the Desktop as shown in the illustration.
- F. Tighten the four pre-installed four Set Screws (21). **Do Not Over-Tighten** as this can deform the frame tubes.

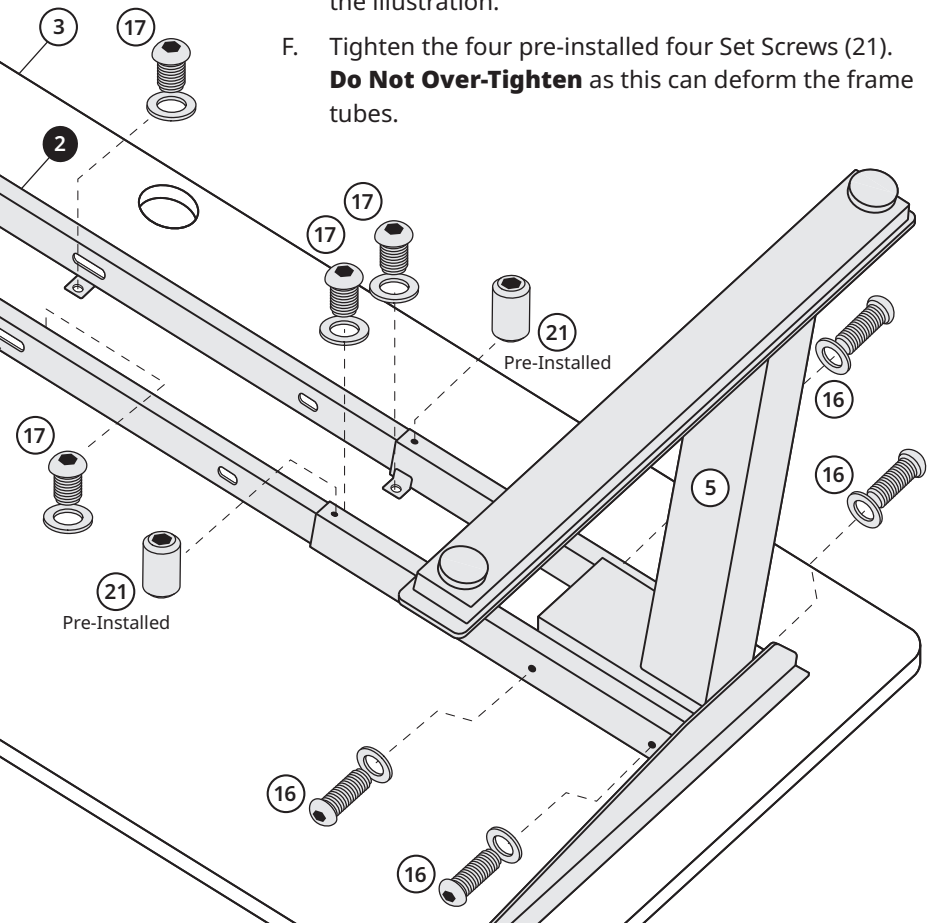

Desk Assembly

Step 5: Attach Electronics Controller Box

LOCATE BAG LABELED STEP 5

Contents: 3 each M4x10L Screws/Washers

- Guide the cable with the square connector(B) to the middle of the desk as shown.
- Connect the 2 pin Power Cable(C) to the Electronics Controller Box(10).
- Secure the Electronics Controller Box(10) in place with three M4 screws(18).
- Attach square connector cables (B, D) to the left side of the Electronics Controller Box(10).

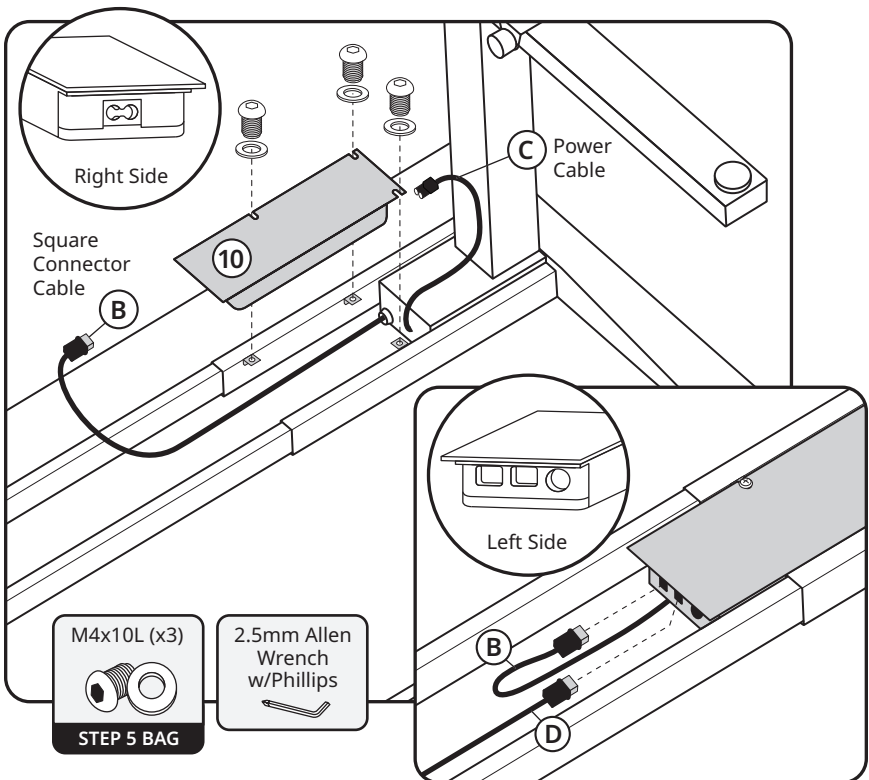

Step 6: Cable Preparation for Console

- A. Connect the 7 pin Data Cable(F) coming from the Front Reinforcement Frame(1) to the 7 pin Data Cable(G) coming from the Right Motorized Leg(4).
- B. Connect the 6 pin Height Adjustment Cable(E) coming from the Front Reinforcement Frame(1) to the 6 pin Height Adjustment Cable Adapter(12) included with the Electronics Control Box(10).
- C. Plug the Height Adjustment Cable Adapter(12) into the Electronics Controller Box(10).

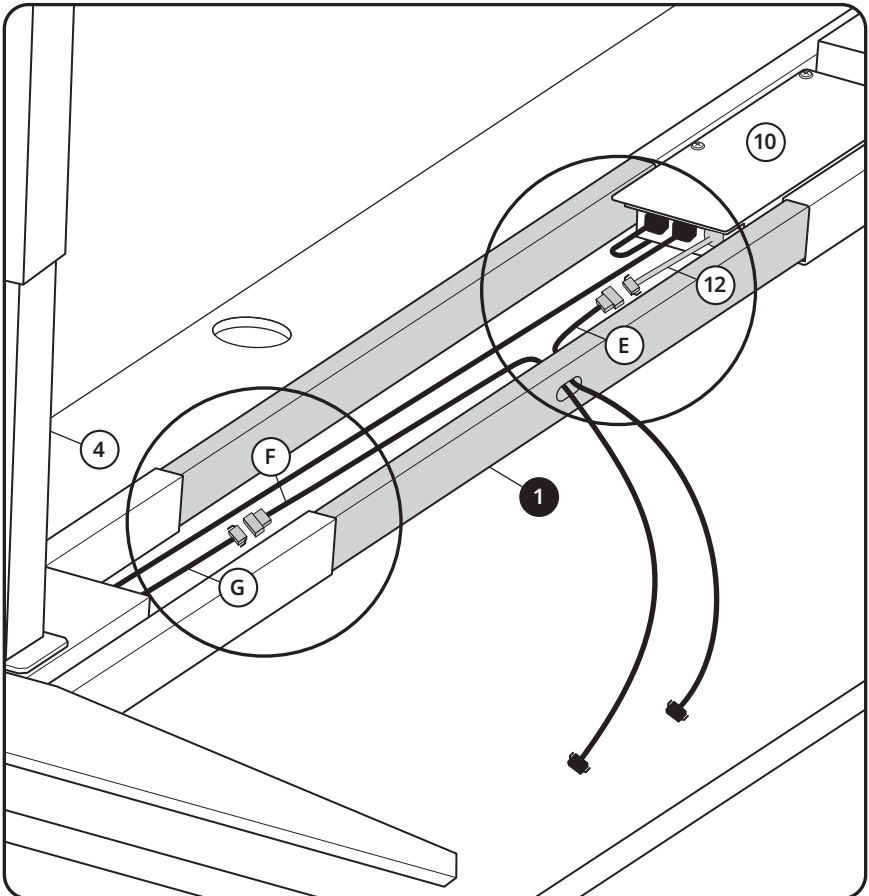

Desk Console Assembly

DT7 Console Assembly

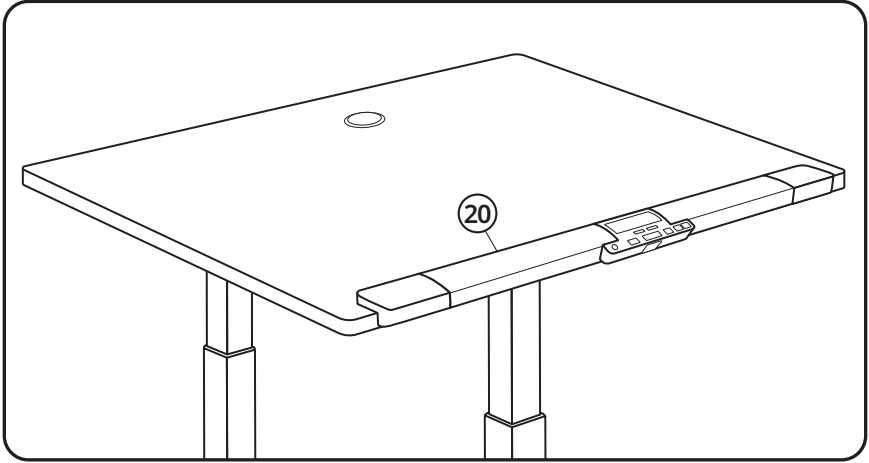

DT7 Console Box

Item#	Qty.	Part Description
20	1	DT7 Console
21	8	M4x15L Screw
22	1	9 Pin Data Cable

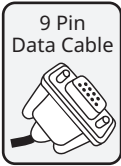

Desk Console Assembly

Step 7: Turn Desk Upright

- A. Use 2 people to lift and turn the desk upright.

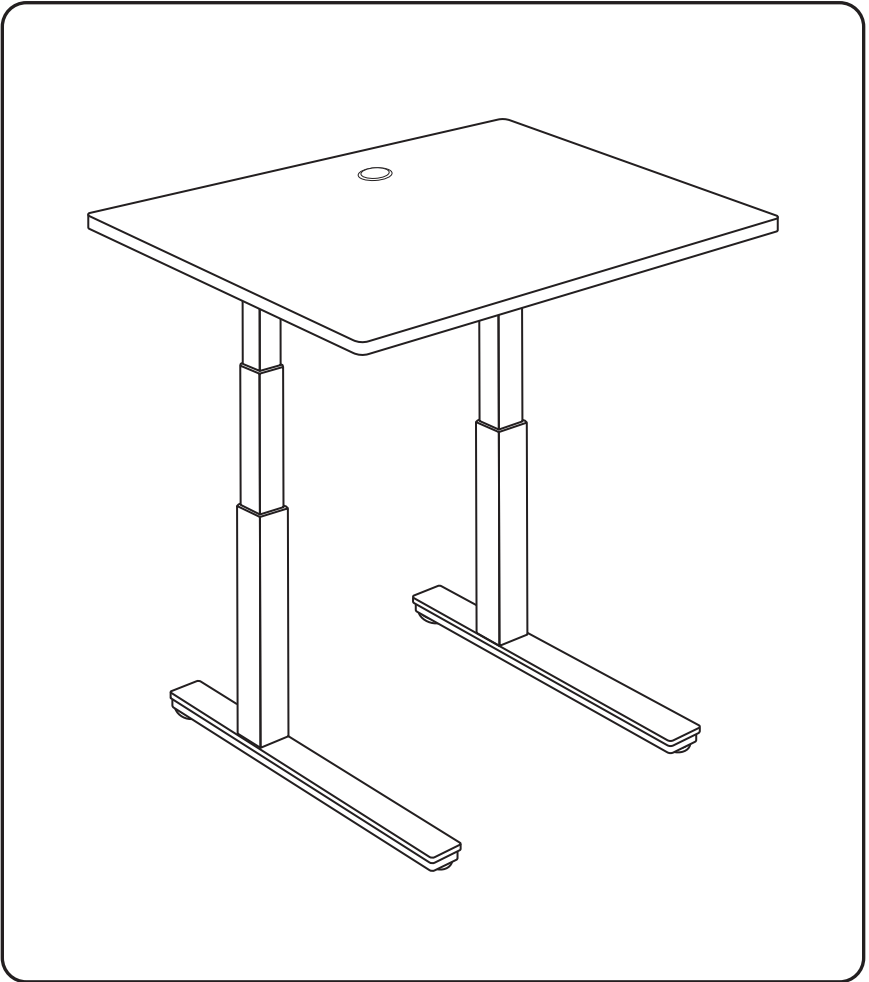

Desk Console Assembly

Step 8: Console Assembly

- A. Using the 5mm Allen Wrench with Screwdriver remove the two pre-installed screws from the back and two screws from the bottom of each console end cap so you can remove the end caps. Notice the difference in the screws from the back and bottom as you will be replacing them back into their proper place.
- B. For 38" desktops, align the Console(20) with pre-drilled holes in the Desktop(3). For 48", 60" and 72" desktops, position the Console where you will use your treadmill or bike base (no pre-drilled holes for 48", 60" and 72" desktop).
- C. Using eight M4x15L Screws(21) attach the Console(20) to the Desktop(3).
- D. Re-install the end caps with the pre-installed screws you removed in Step A.

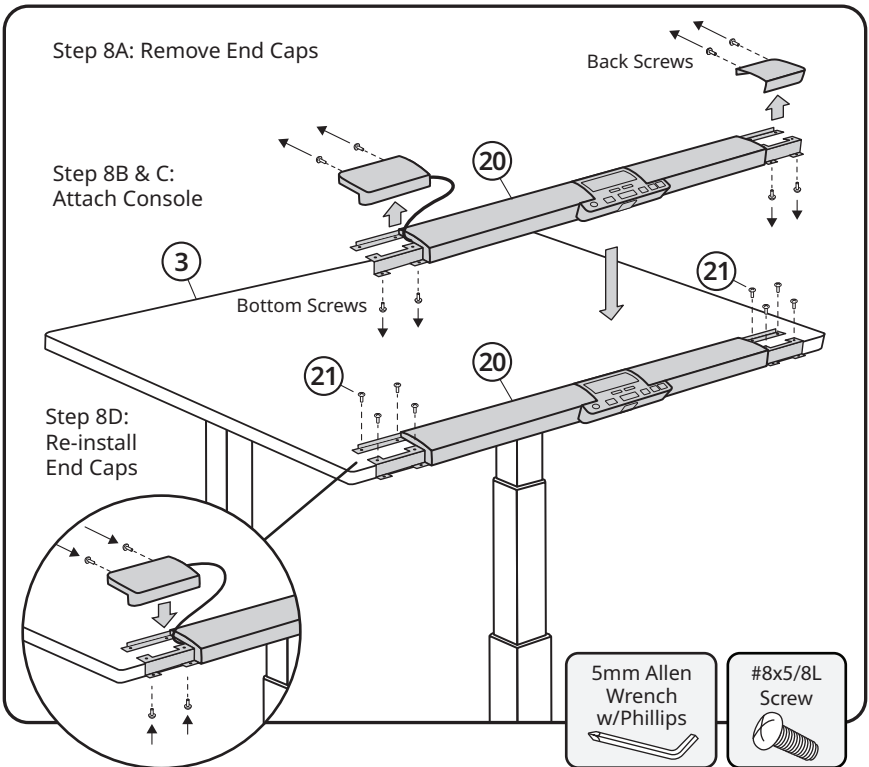

Step 9: Connecting Cables to Console

LOCATE BAG LABELED STEP 9

Contents: 4 Cable Ties

- Locate end of Height Adjustment Cable(E) and Console Data Cable(F) coming from the Front Reinforcement Frame(1).
- Connect the cables (E, F) to the corresponding cables coming from bottom of Console(20).
- Attach cables to underside of Desk with Cable Ties(19) as needed.

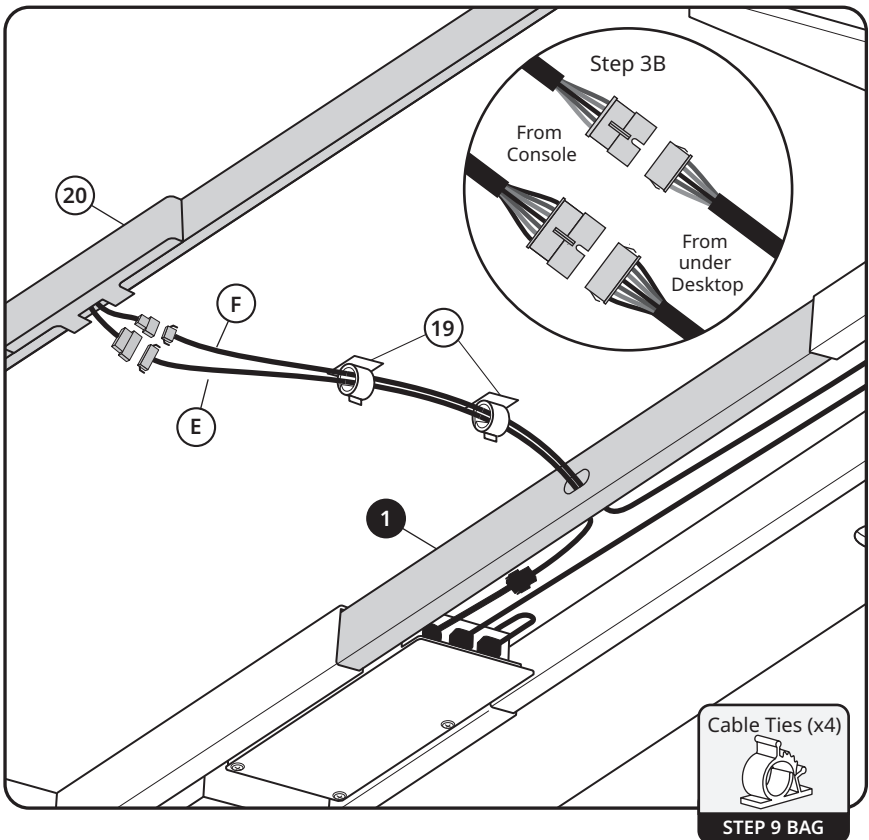

Desk Console Assembly

Step 10: Attach Power

- A. Connect the Power Cord(11) from Left Base Foot(6) to an outlet.

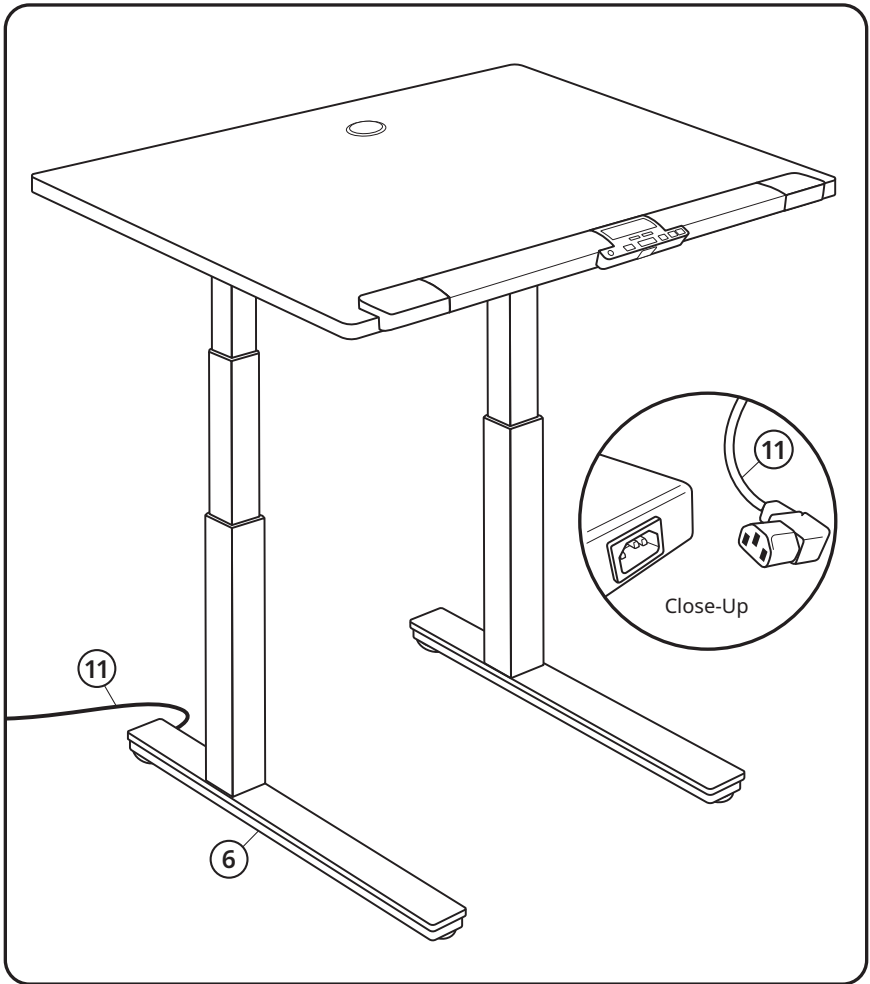

DT7 Electric Treadmill Desk Assembly

Treadmill to DT7 Desk Assembly

- A. Position the pre-assembled treadmill as shown below.
- B. Lift the rear of the treadmill and roll it forward under the desk until the Position Hold Mechanism(D) located on the treadmill are centered over the Positioning Guide Tab(A) at the base of the uprights.

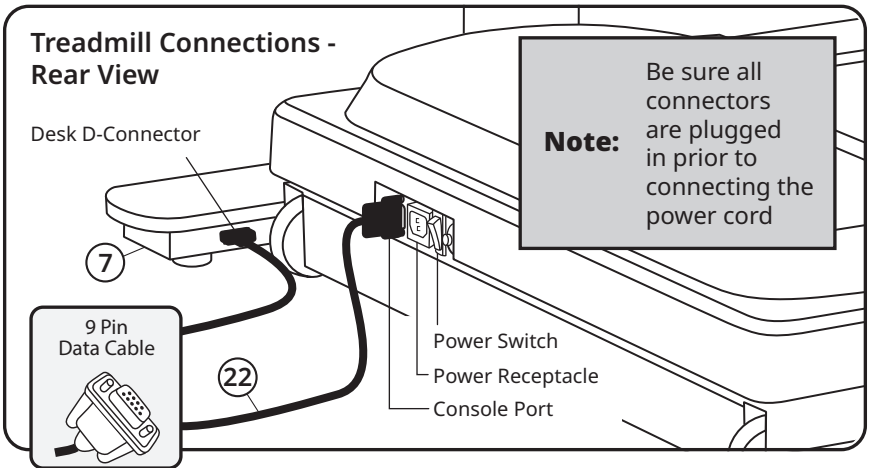
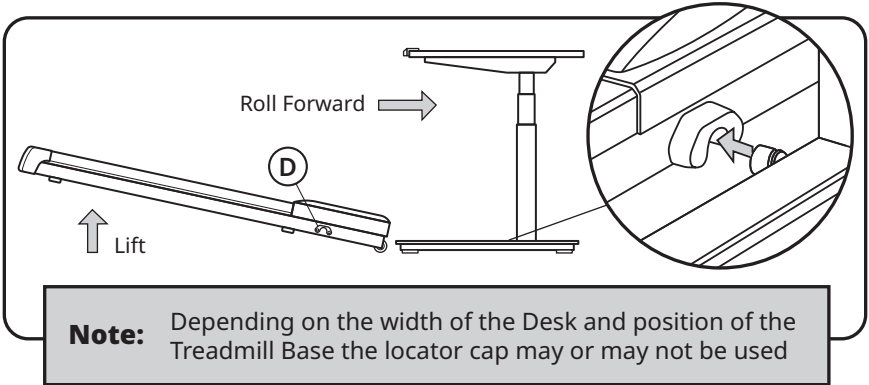

- C. Connect the 9 Pin Data Cable(22) into the Desk D-Connector on the Right Base Foot(7) and treadmill Console Port and tighten the thumb screws.
- D. Plug the Power Cord into the treadmill Power Receptacle on the Left Base Foot(6) and wall outlet.
- F. Turn the treadmill Power Switch on.

DT7 Electric Bike Desk Assembly

Bike to DT7 Desk Assembly

- A. Position the pre-assembled bike as shown below.
- B. Tilt the front of the bike up and roll it forward under the desk to the desired position.

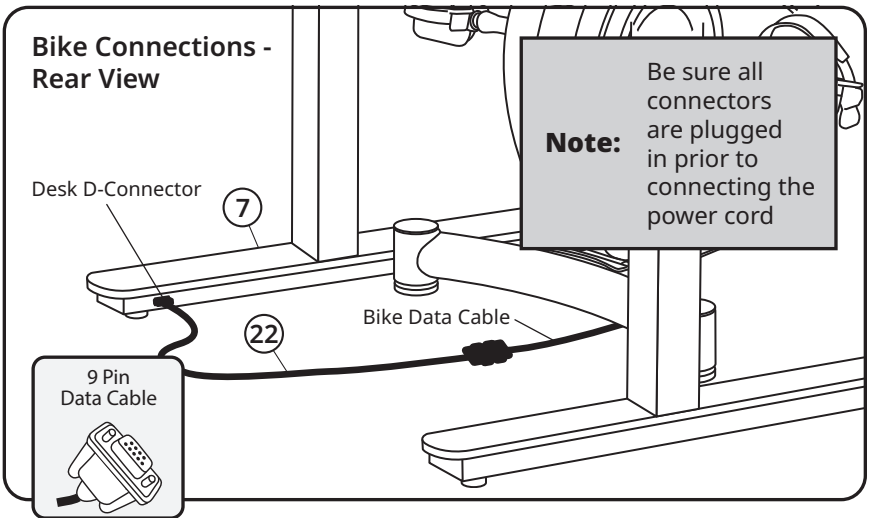
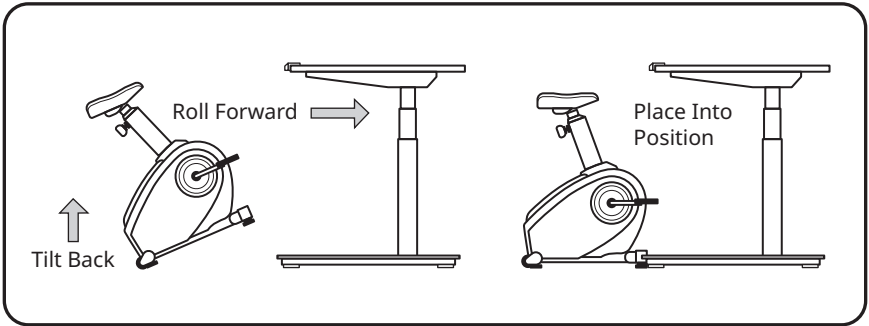

- C. Connect the 9 Pin Data Cable(22) into the Desk D-Connector on the Right Base Foot(7) and bike Data Cable and tighten the thumb screws.
- D. Plug the Power Cord from the back of the bike to a wall outlet.

DT7 Electric Treadmill Desk Moving

Moving Your Treadmill Desk

1. Lift the desk via the frame. If lifting from the desktop or attachments, mounting hardware under the desktop could pull out causing personal or property damage.
2. Move the desk to a level surface and adjust leveling feet as necessary.



CAUTION: When lifting, use proper safety precautions and lifting techniques. Bend your knees and elbows, keep your back straight and lift evenly with both arms.

Treadmill Desk Operation

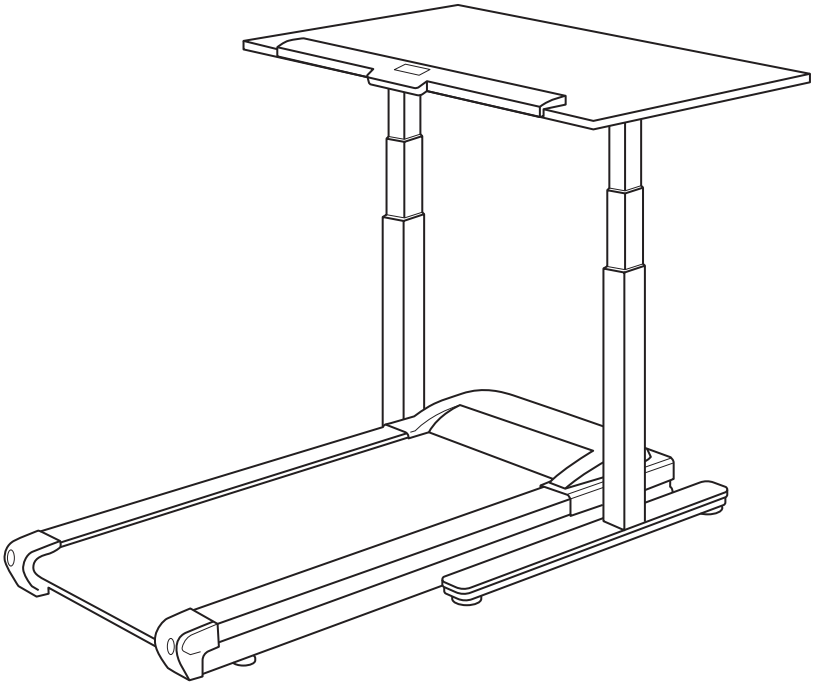

Treadmill Desk Operation

Specifications

Console

Readouts	Time, Steps, Calories, Distance, Speed
Display	White LED
Bluetooth	Yes
Buttons	Power, Start, Stop, Pre-Set Speed, Speed Up/Down, Change Display, Bluetooth, Desk Height Up/Down, 2 Desk Height Presets

Mechanics & Performance

Speed Range	0.4 - 4.0 mph* 0.6 - 6.4 kph	
Dimensions	Four Optional Sizes:	38" W x 29" D in – (96.52" W x 73.66 D cm) 48" W x 29" D in – (120.65 W x 73.66 D cm) 60" W x 29" D in – (152.4 W x 73.66 D cm) 72" W x 29" D in – (182.88 W x 73.66 D cm)
Desktop Height Adjustment Range	27.5 in. to 50.5 in. with 1" Desktop 69.9 cm to 128.3 cm with 1" Desktop	
User Height Range	Up to 6'5" Up to 195 cm	
Height Adjustment Method	Electric	
Desktop Material	1" (2.54 cm) thick high-density Composite Board	
Desktop Surface	Durable Laminate	
Maximum Load on Desktop	220 lbs 100 kg	
Desk Lift Speed	Up 1.7 in/sec, Down 1.9 in/sec Up 4.3 cm/sec, Down 4.8 cm/sec	
Desk Height Memory	2 Pre-Sets	

* Default setting is 2 mph (3.2 kph). Can be changed to max speed of 4 mph/6.4 kph in personal settings

Setting the Clock

The console has a built-in clock that should be re-set to your time zone. This will allow your exercise data to be recorded correctly. Set the time and date with the console keypad.

Console Keypad Manual Adjustment

Using the console keypad, follow these step-by-step instructions:

1. Press and hold **Up** and **Down** buttons together for one second.
2. Press the **Change Display** button once.
* **The display will FLASH and is ready to adjust.**
3. Use the **Up** and **Down** buttons to change the Month.
4. Press the **Change Display** again to save the Month and move to the next setting.
5. Continue this process to adjust Day, Year, Hour, and Minute.

Legend	
<i>EH</i>	Month
<i>d</i>	Day
<i>y</i>	Year
<i>H</i>	Hour
<i>∩</i>	Minute

Treadmill Desk Operation

Starting the Treadmill Desk

1. Turn the On/Off toggle switch located on the front right corner of the treadmill to the On position. If this is already On, press the On/Off button to turn On the console.
2. Make sure the Safety Key is engaged in the console.

Note:

The display will show "----" if the Safety Key is not engaged. Please make sure that the Safety Key is fully engaged. It is possible the display will not show "----" when just partially engaged.

3. Press the Start button to start the treadmill belt. The console will start counting up from 0:00.
4. Press the Up/Down buttons to adjust speed, or use the Preset button to go directly to your preferred speed (which defaults to 1.5 mph). See the separate section on Preset, as well as the section on Settings, for more details.

Treadmill Desk Operation

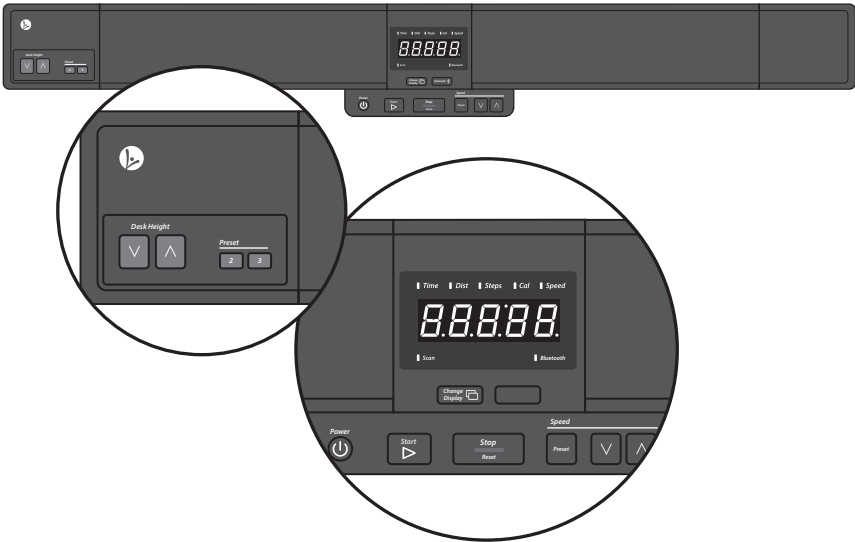

Console Buttons Overview

1. **On/Off:** Turns on the console. When pressed again, turns off the console; the console must be in standby mode (displaying the current time) for the power off function to work.
- 2, **Start:** Starts the treadmill belt. Performs other functions in Settings.
3. **Stop:** Stops the treadmill belt, pausing your use. If pressed for one second, resets the console (all data readouts are reset to zero).
4. **Preset:** When the treadmill belt is moving, changes the speed to 1.5 mph, or to a custom speed that is set in Settings. See separate section on Preset, as well as the section on Settings.
5. **▲ ▼:** Increases or decreases speed by 0.1 mph.
6. **Change Display:** Changes the data readout between Time (the default), Distance, Steps, Calories, and Speed. Press and hold for one second to automatically change readouts every five seconds; press again to stop this automatic change.

Treadmill Desk Operation

Preset (speed) Button: Treadmill Only

Out of the box, the Preset button activates 1.5 mph.

Change the speed in Personal Settings.

This feature may be disabled in Settings, setting Preset to OFF. Default is ON.

Treadmill Desk Innovative Features

Intelli-Step™: LifeSpan treadmill desks come with Intelli-Step, our exclusive step counting feature, that senses each time your foot lands on the walking belt and counts your step total on the display console. If you're in the habit of counting daily steps or want to incorporate a daily or weekly step count goal, this feature will provide more accurate step counting than using a smartwatch or other wearable step counting device on your wrist. Accuracy does require that the treadmill desk is able to detect your steps, and will be less accurate for those who walk lightly, including those individuals under a 100 pounds (45.5 KG).

Intelli-Guard™: This unique safety feature is engaged when the treadmill belt speed reaches 1.0 MPH (1.6 KPH) or faster and automatically pauses the belt 20 seconds after you stop walking, ensuring that no one else steps on the treadmill desk without noticing that it's already running. When Intelli-Guard senses that the treadmill is no longer being used, after 20 seconds the audible beep will first notify you that the treadmill belt is going to pause. This feature can be controlled in Personal Settings.

Treadmill Desk Operation

Personal Settings: there are several features that can be set using our Personal Settings feature to tailor LifeSpan treadmill desks to your specific preferences. These include:

Treadmills Only:

- **Maximum Speed:** Select 2MPH (3.2KPH) or 4MPH (6.4 KPH) maximum speed options.
- **Intelli-Guard Selection:** On / Off setting
- **Resume Speed:** after pressing pause, then starting again, the default belt speed will be .4 MPH (.6 KPH), which is the normal starting speed. The resume starting speed can be modified to be the previous running speed.

Bike and Treadmill:

- **Audible Safety Beep:** On / Off setting. Each time the control buttons on the console are depressed, an audible beep is used as an alert that a change was made. This is designed to prevent accidental speed adjustments being made without users being aware that they may be accidentally depressing a button.
- **Metric versus Standard Readouts:** Change the display readouts for speed and distance to Metric or back to standard readouts.

Interlocking Frames: Since the DT7 is designed specifically to be used for walking with our treadmills, we design this with an extra-large base for added stability, and we interlock our desks and treadmills together so they are virtually impossible to pull over should you need to rely on the desk to keep your balance.

Arm Rest: Foam padding on each side of the console gives you a comfortable place to rest your arms and provides a location to hold onto the desk to keep you located when actively engaged in other activities like walking meetings.

Treadmill Desk Operation

Troubleshooting

The LifeSpan Treadmill Desk is designed and manufactured to be reliable and easy to use. However, if you have a problem, these troubleshooting steps may help you find the cause.

Problem: The console is erratic or not lighting up.

Solution: Check to make sure the treadmill desk is properly plugged in. Turn the power switch off and back on again and make sure the Safety Key is in place. Make sure the connectors located in the front of the treadmill and under the desktop are fully plugged in. If the problem persists contact LifeSpan customer service.

Problem: The treadmill motor seems strained or E1 comes up after several minutes of use.

Solution: The silicone lubricant that is applied to the deck and belt is wearing down and the belt needs to be lubricated with 100% silicone (non-aerosol). Available at www.LifeSpanFitness.com.

Problem: The treadmill automatically pauses during a workout.

Solution: The treadmill is not picking up the step count. Go into the Personal Settings section (page 44) to turn the Intelli-Guard feature off.

Problem: The treadmill speed doesn't feel right (either too fast or too slow).

Solution: Go into the Personal Settings section (page 40-41) and check if you are in Metric or English mode. If you are in the correct mode, contact LifeSpan customer service.

Problem: "UART" appears in the display.

Solution: Turn the treadmill desk power switch off. Unplug and re-plug the connections made in Step C on page 28. Make sure the thumb screws are properly tightened. Turn the treadmill desk power back on and check to see if it functions properly.

Treadmill Desk Operation

Problem: “dc-6” appears in the display.

Solution: Turn the treadmill desk power switch off. Unplug and re-plug the connections made in Step C on page 28. Make sure the thumb screws are properly tightened. Turn the treadmill desk power back on and check to see if it functions properly.

Problem: The desktop surface is not level.

Solution: Check to make sure the base feet are on a level surface. Run calibration by pressing and holding the height \wedge \vee adjustment buttons simultaneously for three seconds.

Problem: The treadmill belt is beginning to slip and needs to be tensioned.

Solution: Refer to the owners manual included with the treadmill base.

Problem: The treadmill belt is beginning to drift to the left or right and needs to be aligned.

Solution: Refer to the owner's manual included with the treadmill base.

Treadmill Desk Operation

Personal Settings

Press and hold Change Display for one second to enter Settings mode.

Press the up or down arrows to move through the various settings. Press Start to choose a setting to change.

Press the up or down arrows to move through the various choices for that setting.

Press Start to select a choice. This takes you back to settings mode, where you can move through the other settings.

Press Stop to exit Settings mode.

Intelli-Guard — Intelli-Guard ON/OFF.

Speed Reset — Controls whether, after a Pause, the treadmill resumes the most recent walking speed, or resets to 0.4 mph. If ON, the speed resets to 0.4 mph.

Beep — Turns off the normal treadmill beep that happens at every button press.

Speed Limit — The maximum speed of the treadmill.

Preset — Turns on and off the Preset feature. Turning this off is desirable in a group environment.

Preset Speed — Changes the preset speed from something other than the default of 1.5.

Weight — Changes the default bodyweight from something other than the default of 150 pounds / 70 kilograms.

Units of Measure — Choose English (Imperial) or Metric.

Multi-User — Choose yes if more than one person will be using the treadmill desk.

Bluetooth-Auto — Choose whether to automatically pair.

Treadmill Desk Operation

Sleep Function — Choose whether the console has a Sleep, or Auto-Power-Off function when the console is paused. The default function is No Sleep. If you choose to enable the Sleep function, you can choose to wait 10 minutes before sleep, or 20 minutes.

Display Details

Setting	Setting Displayed	Choice 1 (Default)	Choice 2
Enter Settings mode:	SETTG	n/a	n/a
Intelli-Guard	GUARD	ON	OFF
Speed Reset:	RESET	OFF	ON
Beep:	BEEP	ON	OFF
Speed Limit:	L	2	4
Pre Set:	SET	ON	OFF
Preset Speed	SPEED	1.5	+/- 0.1
User Weight:	T	150/70	+/- 1
Units of Measure:	UNITS	ENGL	(M)TRIC
Multi-User:	USER	NO	YES
Bluetooth-Auto:	BT-A	OFF	ON
Sleep	SLEEP	NO	10/20

Bike Desk Operation

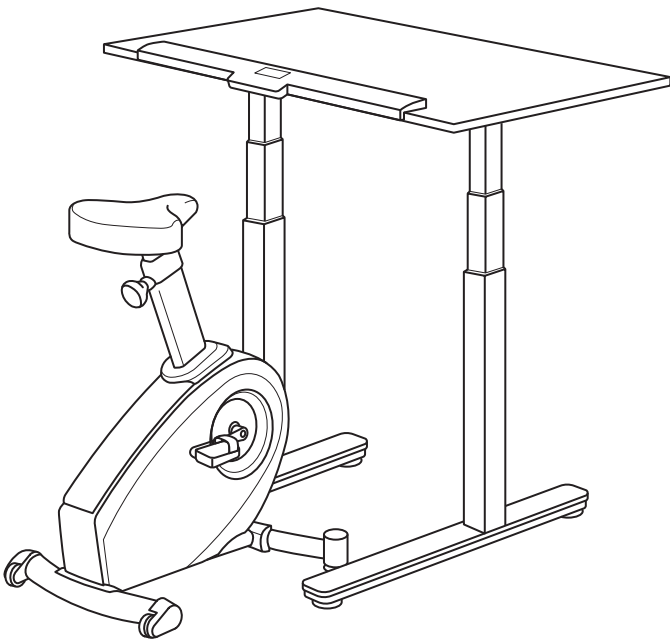

Bike Desk Operation

Specifications

Console

Readouts	Time, Revolutions, Calories, Distance, Speed
Display	LED
Bluetooth	Yes

Mechanics & Performance

Resistance Level	16 Levels
Dimensions	Four Optional Sizes: 38" W x 29" D in – (96.52" W x 73.66 D cm) 48" W x 29" D in – (120.65 W x 73.66 D cm) 60" W x 29" D in – (152.4 W x 73.66 D cm) 72" W x 29" D in – (182.88 W x 73.66 D cm)
Desktop Height Adjustment Range	27.5 in. to 50.5 in. with 1" Desktop 69.9 cm to 128.3 cm with 1" Desktop
Height Adjustment Method	Electric
Desktop Material	1" (2.54 cm) thick high-density Composite Board
Desktop Surface	Durable Laminate
Maximum Load on Desktop	220 lbs 100 kg
Desk Lift Speed	Up 1.7 in/sec, Down 1.9 in/sec Up 4.3 cm/sec, Down 4.8 cm/sec
Desk Height Memory	2 Pre-Sets

Setting the Clock

The console has a built-in clock that should be re-set to your time zone. This will allow your exercise data to be recorded correctly. Set the time and date with the console keypad.

Console Keypad Manual Adjustment

Using the console keypad, follow these step-by-step instructions:

1. Press and hold **Up** and **Down** buttons together for one second.
2. Press the **Change Display** button once.
* **The display will FLASH and is ready to adjust.**
3. Use the **Up** and **Down** buttons to change the Month.
4. Press the **Change Display** again to save the Month and move to the next setting.
5. Continue this process to adjust Day, Year, Hour, and Minute.

Legend	
<i>EH</i>	Month
<i>d</i>	Day
<i>Y</i>	Year
<i>H</i>	Hour
<i>∩</i>	Minute

Bike Desk Operation

Starting the Bike Desk

1. Press the On/Off button to turn on the console.
2. Press the Start, and start pedaling. The console will start counting up from 0:00.
3. Press the Up/Down buttons to adjust resistance.

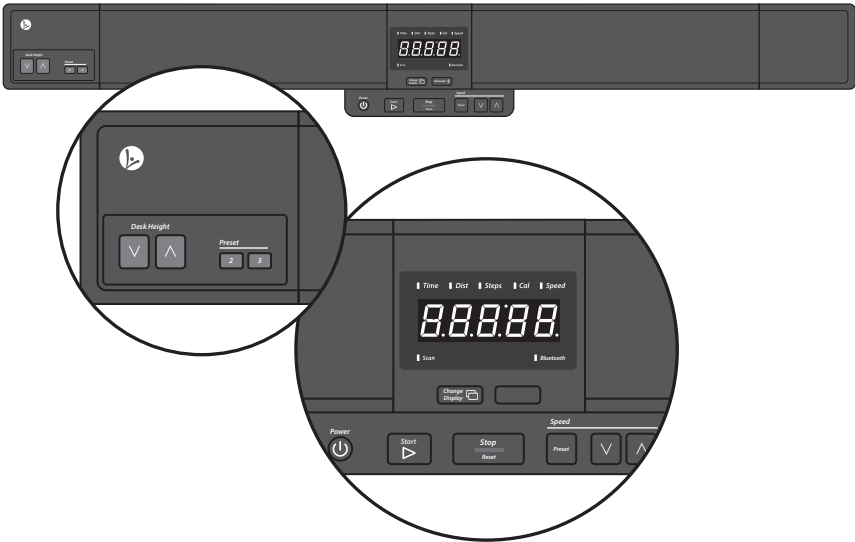

Console Buttons Overview

1. **On/Off:** Turns on the console. When pressed again, turns off the console; the console must be in standby mode (displaying the current time) for the power off function to work.
2. **Start:** Starts the bike. Performs other functions in Settings.
3. **Stop:** Stops the bike, pausing your use. If pressed for one second, resets the console (all data readouts are reset to zero).
4. **Preset:** This feature is used in a treadmill desk setting and is not applicable to a bike desk.
5. **^ V** : Increases or decreases resistance by one level.
6. **Change Display:** Changes the data readout between Time (the default), Distance, Steps (Pedal Revolutions), Calories, and Speed. Press and hold for one second to automatically change readouts every five seconds; press again to stop this automatic change.

Bike Desk Operation

Bike Desk Innovative Features

The following features are applicable to both treadmill desk and bike desk users.

- **Audible Safety Beep:** On / Off setting. Each time the control buttons on the console are depressed an audible beep is used as an alert that a change was made. This is designed to prevent accidental speed adjustments being made without users being aware that they may be accidentally depressing a button.
- **Metric versus Standard Readouts:** Change the display readouts for speed and distance to Metric or back to standard readouts.

Troubleshooting

This bike desk has been designed and manufactured to be reliable and easy to use. However, if you have a problem, these troubleshooting steps may help you find the cause.

Problem: The console is erratic or not lighting up.

Solution: Check to make sure the bike is properly plugged in. Make sure the connectors on the bike and under the desktop are fully plugged in. If the problem persists contact LifeSpan customer service.

Problem: "UART" appears in the display.

Solution: Turn the bike desk power switch off. Unplug and re-plug the connections made in Step C on page 29. Make sure the thumb screws are properly tightened. Unplug the bike and plug it back in and check to see if it functions properly.

Problem: "dc-6" appears in the display.

Solution: Turn the bike desk power switch off. Unplug and re-plug the connections made in Step C on page 29. Make sure the thumb screws are properly tightened. Unplug the bike and plug it back in and check to see if it functions properly.

Problem: The desktop surface is not level.

Solution: Check to make sure the base feet are on a level surface. Run calibration by pressing and holding the height adjustment buttons simultaneously for three seconds

Bike Desk Operation

Personal Settings

Press and hold Change Display for one second to enter Settings mode.

Press the up or down arrows to move through the various settings. Press Start to choose a setting to change.

Press the up or down arrows to move through the various choices for that setting.

Press Start to select a choice. This takes you back to settings mode, where you can move through the other settings.

Press Stop to exit Settings mode.

Beep — Turns off the normal treadmill beep that happens at every button press.

Weight — Changes the default bodyweight from something other than the default of 150 pounds / 70 kilograms.

Units of Measure — Choose English (Imperial) or Metric.

Multi-User — Choose yes if more than one person will be using the bike desk.

Bluetooth-Auto — Choose whether to automatically pair. Optimized safe operation for either single or multiple users.

Sleep Function — Choose whether the console has a Sleep, or Auto-Power-Off function when the console is paused. The default function is No Sleep. If you choose to enable the Sleep function, you can choose to wait 10 minutes before sleep, or 20 minutes.

Display Details

Setting	Setting Displayed	Choice 1 (Default)	Choice 2
Enter Settings mode:	SETTG	n/a	n/a
Beep:	BEEP	ON	OFF
User Weight:	T	150/70	+/- 1
Units of Measure:	UNITS	ENGL	(M)TRIC
Multi-User:	USER	NO	YES
Bluetooth-Auto:	BT-A	OFF	ON
Sleep	SLEEP	NO	10/20

DT7

Treadmill/Bike Desk

LifeSpan Fitness

785 West 1700 South Suite 1
Salt Lake City, UT. 84104

Phone: 877.654.3837
www.LifeSpanFitness.com

Version 2.3 – Sept 2020