

## Diaphragm valve T4 [hand operated]

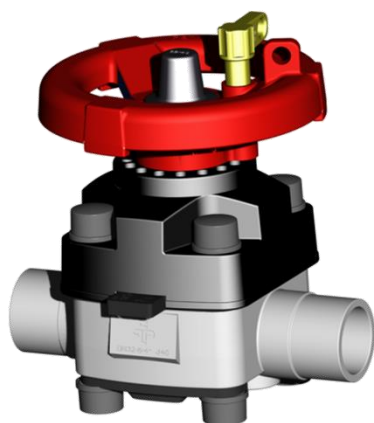
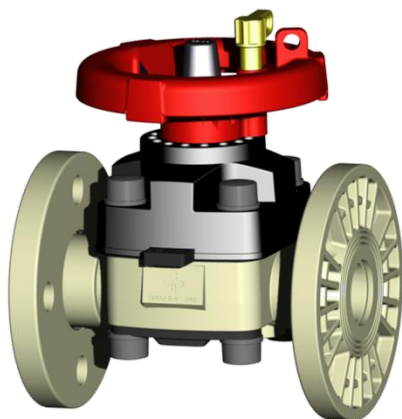
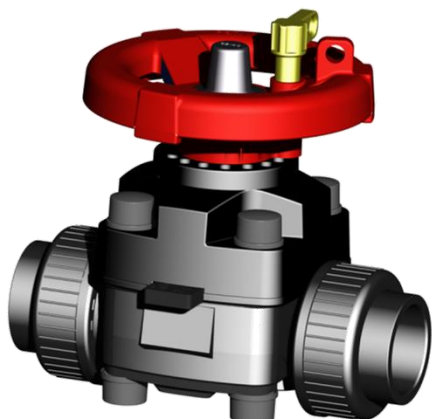

### General:

- Body material: PVC-U, PP, PVDF
- Seals: EPDM, FPM
- Diaphragm: EPDM, EPDM/PTFE
- Dimensions: DN15 – DN125  
d20 – d140  
1/2" – 4"

### Connections:

- Solvent socket PVC DIN / ISO / ASTM / JIS
- Solvent spigot PVC DIN
- Threaded socket PVC BSP
- Fusion spigot PP / PVDF DIN
- Fusion socket PP / PVDF / PE DIN
- Backing flange PVC / PP-GFK DIN / ANSI
- Fix flange PVC / PP DIN / ANSI / JIS / BS
- Fixflange PP / PVDF DIN / ANSI / JIS / BS

**Operating pressure:** PN10

### Technical features:

- safety gear wheel
- corrosion resistant
- longworking life
- suitable for aggressive and dirty media
- radial installation or removal
- easy replacement of the diaphragm

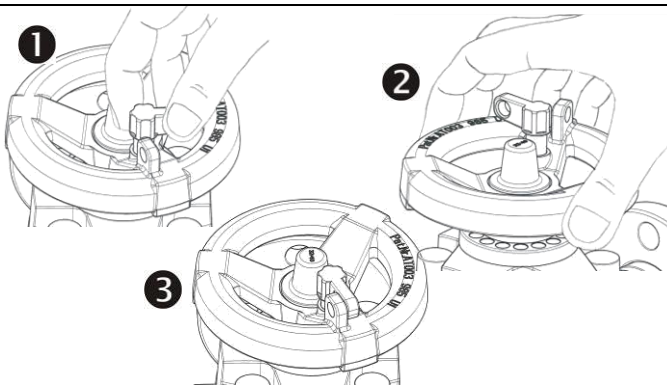

This document does not constitute a guarantee, it is for initial information purposes only. The product range is continually upgraded, the designs and types therefore only reflect the state of the art at the time of printing.

# Diaphragm valve T4

[hand operated]



## Dimensions:

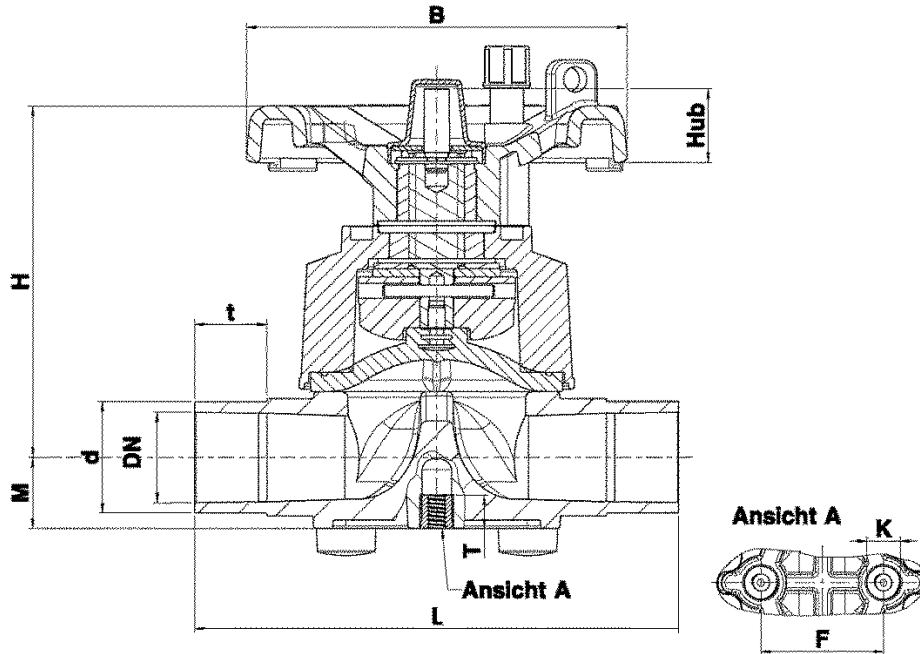

### PVC-U / PP / PVDF

#### Connector type

PVC solvent spigot

PP / PVDF fusion spigot

Dimensions DN80-DN125 see page 5

DN	15	20	25	32	40	50	65
d	20	25	32	40	50	63	75
inch	1/2"	3/4"	1"	1 1/4"	1 1/2"	2"	2 1/2"
M PVC	17	17	21	33	33	40,5	25
M PP / PVDF	16,5	19	22	26	31	38	25
H	100	100	107	144	144	170	260
B	86	86	86	136	136	136	234
F	25	25	25	45	45	45	-
Hub	9	9	11	22	22	28	35
K	M6	M6	M6	M8	M8	M8	-
L	124	144	154	174	194	224	284
T	12	12	12	15	15	15	-
t <sub>KS</sub> <sup>1</sup>	16	19	22	26	31	38	44
t <sub>SS</sub> <sup>2</sup>	28,5	36	36	38,5	46	46	37
PN	10	10	10	10	10	10	10

Dimensions in mm

<sup>1</sup> KS = solvent spigot

<sup>2</sup> SS = fusion spigot

- = no thread inserts starting with DN65

# Diaphragm valve T4 [hand operated]

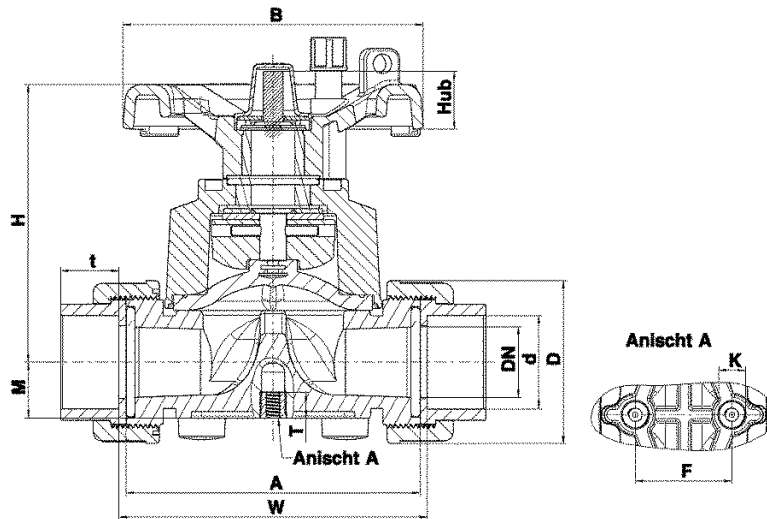

### PVC-U / PP / PVDF

#### Connector type

PVC solvent socket / threaded socket

PE / PP / PVDF fusion socket

Dimensions DN80-DN125 see page 5

	DN	15	20	25	32	40	50
	d	20	25	32	40	50	63
	inch	1/2"	3/4"	1"	1 1/4"	1 1/2"	2"
	H	100	100	107	144	144	170
	B	86	86	86	136	136	136
	F	25	25	25	45	45	45
	K	M6	M6	M6	M8	M8	M8
	Hub	9	9	11	22	22	28
PVC	t <sub>GM</sub> <sup>1</sup>	16	19	22	26	31	38
	t <sub>KM</sub> <sup>2</sup>	16	19	22	26	31	38
	t <sub>SM</sub> <sup>3</sup> PE	16	17,5	19,5	22	25	29
	G <sub>GM</sub> <sup>1</sup>	1/2"	3/4"	1"	1 1/4"	1 1/2"	2"
	A	90	108	116	136	154	184
	D	43	53	60	74	83	103
	M	17	17	21	33	33	40,5
	W <sub>GM</sub> <sup>1</sup> KM <sup>2</sup>	96	114	122	142	160	190
W <sub>SM</sub> <sup>3</sup> (PE)	95	116	126	148	173	209	
PP / PVDF	t <sub>SM</sub> <sup>2</sup> (PP/PVDF)	16	18	20	22	24,5	29
	A	90	108	116	136	154	184
	D	47	57	64	78	89	109
	M	16,5	16,5	20	25,5	32	38,5
	W <sub>SM</sub> <sup>3</sup>	96	114	122	142	161	190
PN	10	10	10	10	10	10	10

Dimensions in mm

<sup>1</sup> GM = threaded socket

<sup>3</sup> SM = fusion socket

<sup>2</sup> KM = solvent socket

# Diaphragm valve T4 [hand operated]

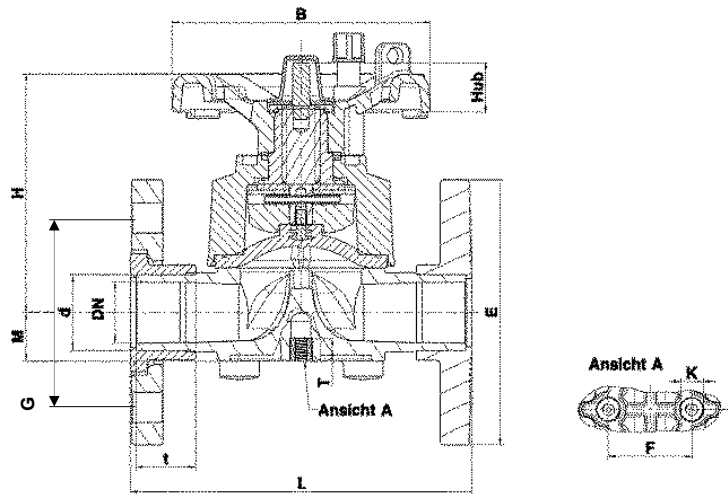

### PVC-U / PP / PVDF

#### Connector type

PVC backing flange / fix flange

PP backing flange with steel inlay / fix flange / Fixflange

PVDF backing flange

Dimensions DN80-DN125 see page 5

	DN	15	20	25	32	40	50	65
	d	20	25	32	40	50	63	75
	zoll	1/2"	3/4"	1"	1 1/4"	1 1/2"	2"	2 1/2"
	H	100	100	107	144	144	170	260
	B	86	86	86	136	136	136	234
	F	25	25	25	45	45	45	-
	K	M6	M6	M6	M8	M8	M8	-
	Hub	9	9	11	22	22	28	35
PVC	E <sub>LF</sub> <sup>1</sup>	95	105	115	140	150	165	-
	E <sub>FF</sub> <sup>2</sup>	97	105	125	140	150	165	185
	G <sub>DIN</sub>	-	-	-	-	-	-	145
	L <sub>LF</sub> <sup>1</sup>	130	150	160	180	200	230	-
	L <sub>FF</sub> <sup>2</sup>	130	150	160	180	200	230	290
	M	17	17	21	33	33	40,5	25
PP / PVDF	E <sub>LF</sub> <sup>1</sup> DIN	95	108	115	140	151	165	186
	E <sub>LF</sub> <sup>1</sup> ANSI	95	102	114	130	133	162	184
	E* <sub>FF</sub> <sup>2</sup>	95	105	115	-	-	-	-
	E* <sub>FIF</sub> <sup>3</sup>	95	105	115	140	150	165	-
	G <sub>DIN</sub>	-	75	85	100	110	125	145
	G <sub>ANSI</sub>	-	69,8	79,4	89	98,5	120,65	-
	G <sub>JIS</sub>	-	75	90	100	105	120	-
	L <sub>LF</sub> <sup>1</sup>	130	150	160	180	200	230	294
	L <sub>FF</sub> <sup>2</sup>	130	150	160	-	-	-	-
	L <sub>FIF</sub> <sup>3</sup>	130	150	160	180	200	230	-
M	16,5	16,5	20	25,5	32	38,5	25	
J <sup>4</sup>	4	4	4	4	4	4	4	4
PN	10	10	10	10	10	10	10	10

Dimensions in mm

<sup>1</sup> LF = backing flange    <sup>2</sup> FF = fix flange    <sup>3</sup> FIF = Fixflange    <sup>4</sup> J = Number of drill holes    - = currently unrealised



**Diaphragm valve T4**  
[hand operated]

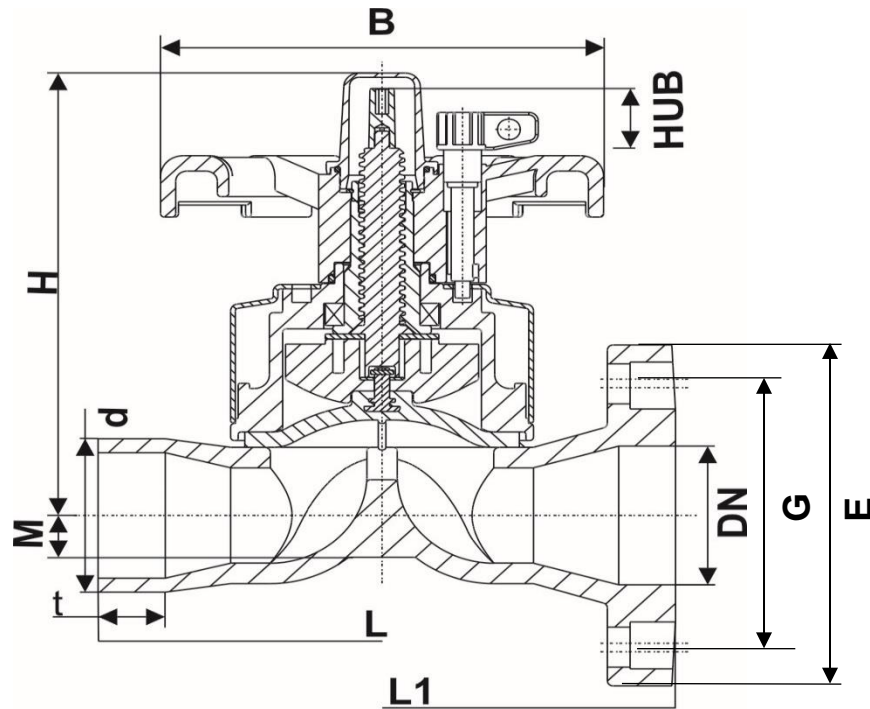

**PVC-U / PP / PVDF**

**Connector type**

PVC / PP / PVDF Fixflange

PP / PVDF fusion spigot

DN	80	100	125
d	90	110	140
zoll	3"	4"	5"
M	25	25	25
H	260	330	330
B	234	234	234
Hub	35	45	45
E <sub>FIF</sub> <sup>1</sup>	200	229	250
G <sub>DIN</sub>	160	180	210
G <sub>ANSI</sub>	152,4	190,5	-
G <sub>JIS</sub>	160	185	-
L1 <sub>FL</sub> <sup>1</sup>	310	350	400
L* <sub>SS</sub> <sup>2</sup>	300	340	-
t <sub>SS</sub> <sup>2</sup>	37	50	-
J <sup>3</sup>	8	8	8
PN	10	10	10

Dimensions in mm

\* = only PP and PVDF

<sup>1</sup> FL = Fixflange

<sup>2</sup> SS = fusion spigot

<sup>3</sup> J = Number of drill holes

# Diaphragm valve T4 [hand operated]



## Exploded drawing:

- 01. Positioning bolt
- 02. Sight glass
- 03. Indication disk
- 04. Circlip
- 05. Shim
- 06. Gear wheel
- 07. Cover
- 08. Hex nut
- 09. Shim
- 10. Disk
- 11. O-Ring
- 12. Bonnet
- 13. Screen socket
- 14. Positioning indicator
- 15. Dowel pin
- 16. Distance disk
- 17. Compressor
- 18. Dowel pin
- 19. Diaphragm split\*
- 20. Bottom
- 21. Insert nut
- 22. Screw (from DN100 with 8 screws)
- 23. Flange
- 24. Flange adaptor
- 28. Spring
- 29. Covering for Bonnet
- 30. Axial deep groove ball bearing
- 31. Shim
- 32. Diaphragm split\*
- 33. Plate (only PP)
- 34. Diaphragm

\* off DN65 PTFE-coated diaphragms are split (see exploded drawing DN65-DN125)

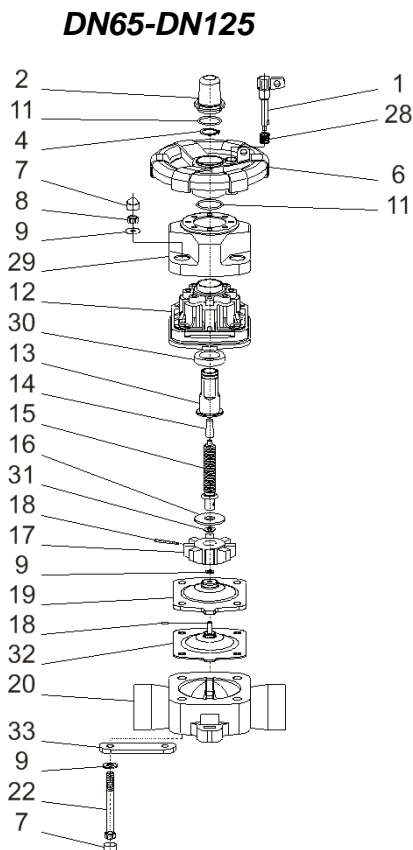
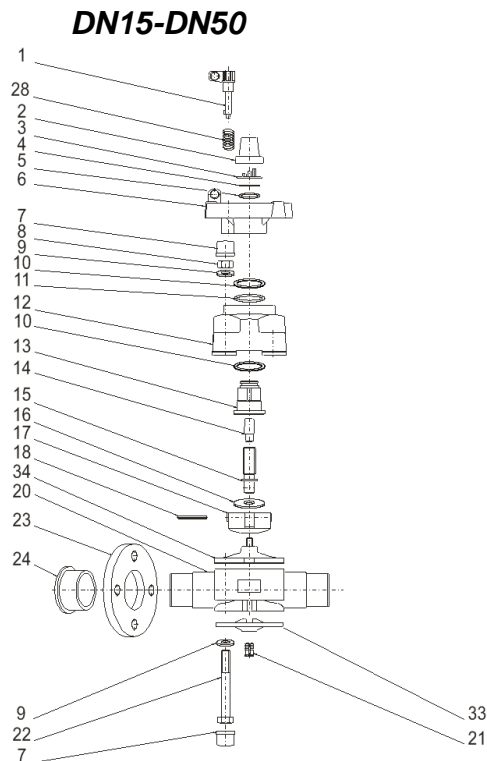

# Diaphragm valve T4 [hand operated]



**Diagrams:**

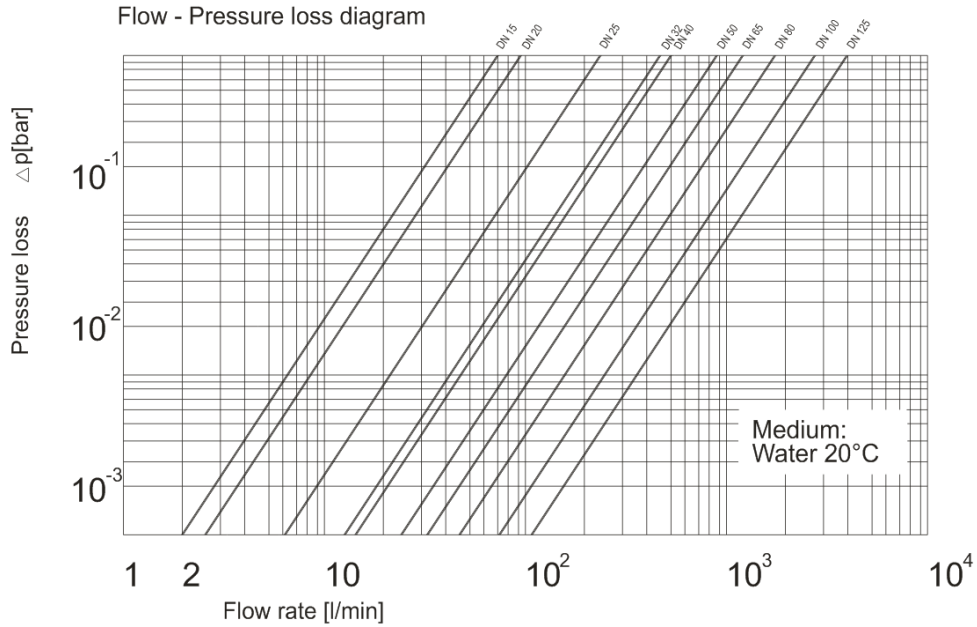

**Cv value table**

Pressure loss	DN15	DN20	DN25	DN32	DN40	DN50	DN65	DN80	DN100	DN125
1 bar	70 l/min	95 l/min	250 l/min	450 l/min	500 l/min	880 l/min	1.100 l/min	1.700 l/min	2.700 l/min	4.000 l/min

**Pressure – Temperature diagram – PVC-U**

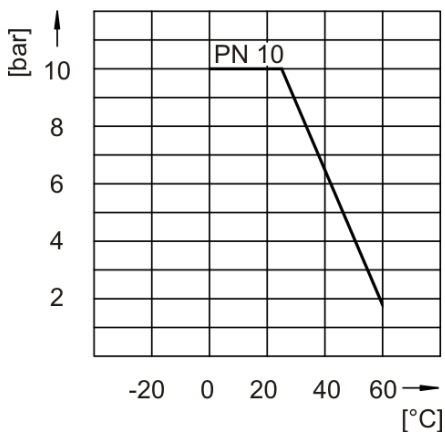

**Pressure – Temperature diagram - PP**

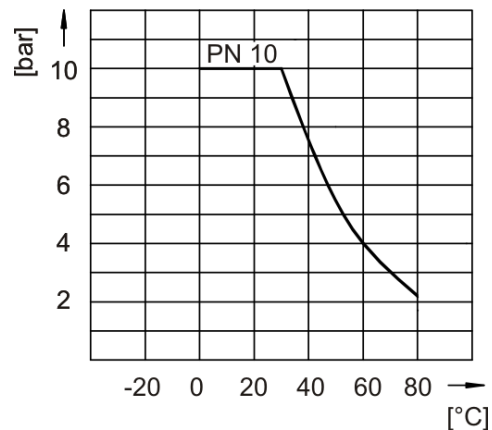

© Praher Plastics Austria GmbH DB/DEEN/18/07/295/F Subject to technical modifications!



**Diaphragm valve T4**  
[hand operated]



Pressure – Temperature diagram – PVDF

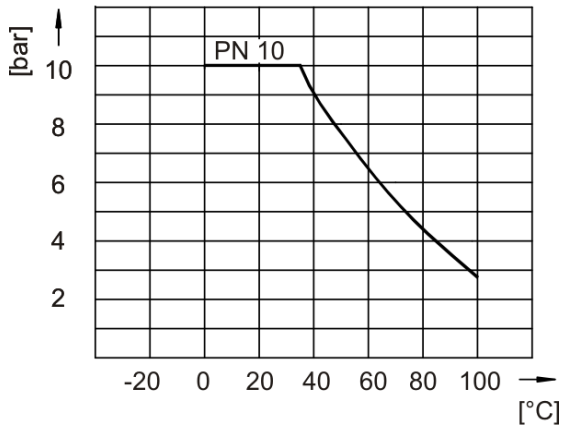

Closing torque of gear wheel

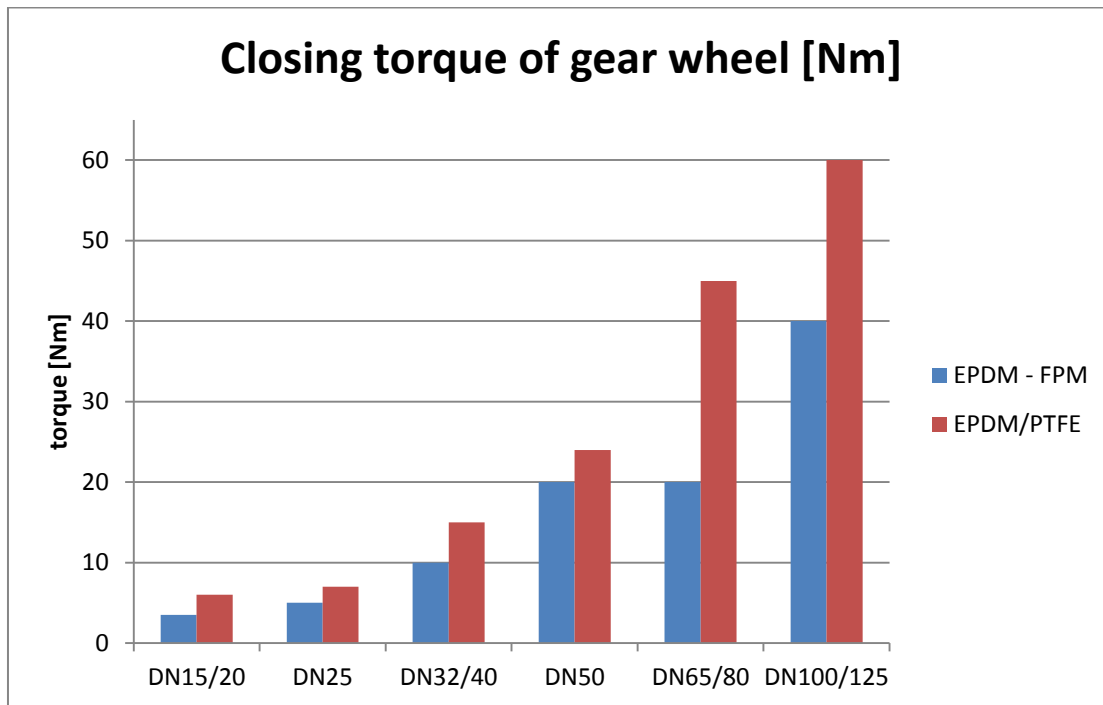

Closing torque of gear wheel [Nm]		
Dimension	EPDM - FPM	EPDM/PTFE
DN15/20	3,5	6
DN25	5	7
DN32/40	10	15
DN50	20	24
DN65/80	20	45
DN100/125	40	60



**Diaphragm valve T4**  
[hand operated]



Tightening torque of screws

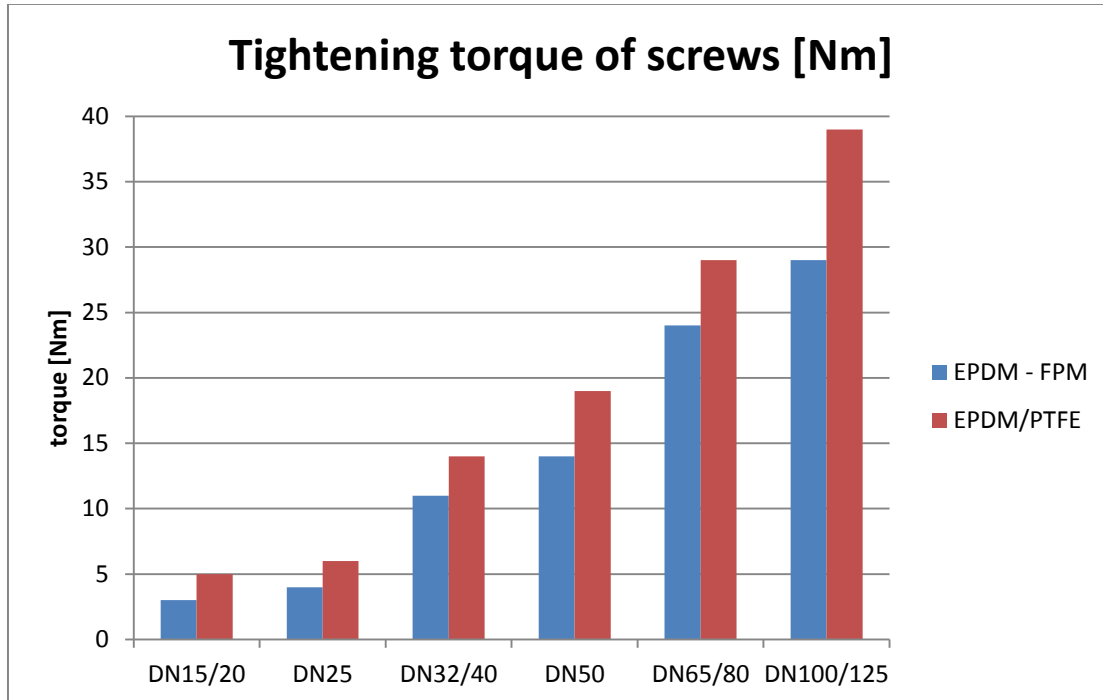

Tightening torque of screws [Nm]		
Dimension	EPDM - FPM	EPDM/PTFE
DN15/20	3	5
DN25	4	6
DN32/40	11	14
DN50	14	19
DN65/80	24	29
DN100/125	29	39

**Application note:**

Before and after the pressure test it is recommended to retighten the screws crosswise. During retightening of the screws there should be no pressure on the valve and the valve should be in open position.

# Diaphragm valve T4 [hand operated]

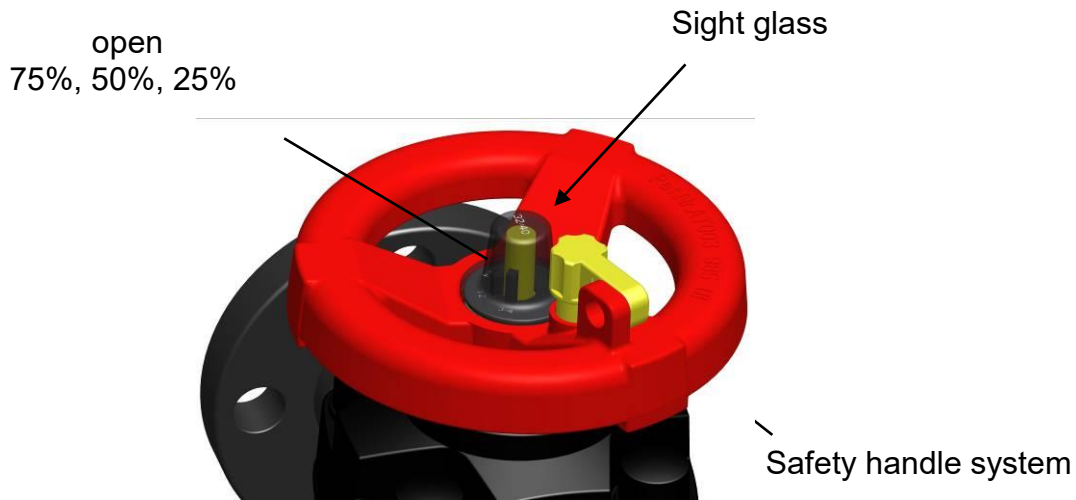

## Emptying of diaphragm valves

In order to achieve the optimum emptying of the diaphragm valve in horizontal mounted piping systems, we recommend the installation of the diaphragm valve according to the respective angle of rotation and an installation down-grade about 2°.

