

AIR RELEASE VALVE

Fluidflo Valve Solutions



Plastic series

AUTOMATIC AIR RELEASE VALVE



Hydrodynamic design

This air release valve has been designed for an efficient discharge of large air volumes from small water network systems, filters, containers, and others devices where trapped air may impair the system's operation.



Operation modes

- 1.** Discharge of large quantities of air at a high flow velocity when the conduit is being filled. When the water arrives to the valve, the main float rises up and closes the outlet.
- 2.** The automatic air valve maintains automatically and continuously its purging function on all the air bag that could reach the air valve, it causes the immediate descent of the float and partial or total opening of the closing orifice. The water pressure does not prevent this function.



Applications

- ✓ - Expelling the air at high flow velocity during the initial filling of the systems.
- ✓ - Introducing air when the pipe drains, maintaining atmospheric pressures in the pipe, preventing collapse and cavitation damage to the conduits.
- ✓ - Relieving the entrained air from the water, while the network is pressurized.

- 3.** The air goes in the pipe when the internal pressure is below atmospheric pressure. The difference in pressure causes the float to be positioned in an open position, allowing the air coming into the pipe.

AUTOMATIC 1" - 3/4" - 1/2"



Disassembly

Parts	Components	Material
1	Base	Polyamide with fiberglass
2	O-ring	NBR
3	Float	Polypropylene
4	Body	Polyamide with fiberglass
5	Valve seal	EPDM



Dimensions

Dimensions	1"	3/4"	1/2"
H	136 mm	115 mm	115 mm
W	86 mm	59 mm	59 mm
D	BSP 1" male	BSP 3/4" male	BSP 1/2" male
A	25 mm ²	25 mm ²	25 mm ²
Weight	0,31 kg	0,14 kg	0,14 kg

Service pressure: PN16

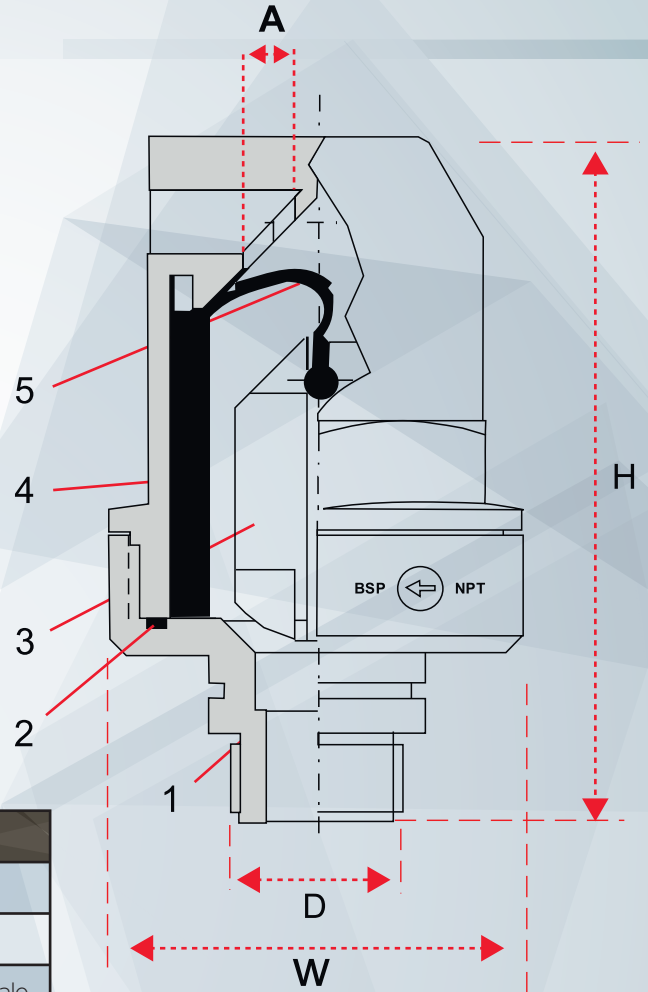

Air discharge

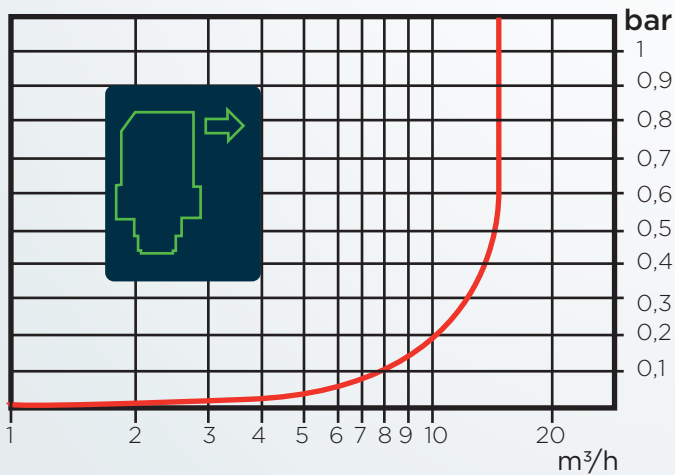

Air intake

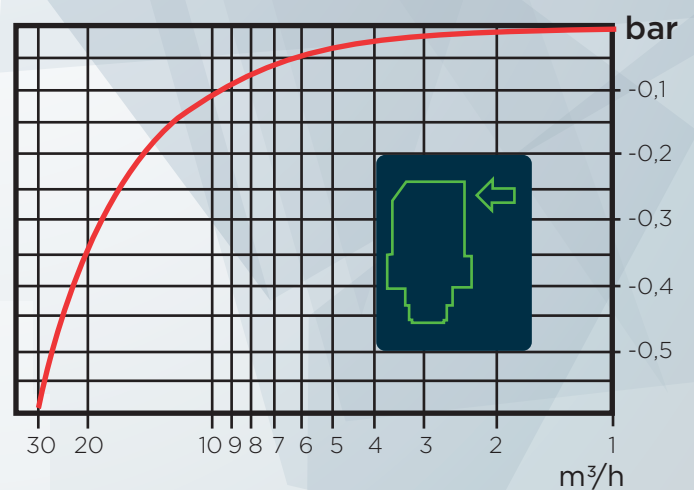

AUTOMATIC 2"

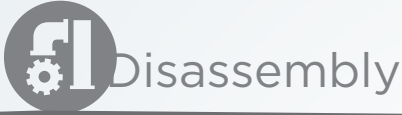

Parts	Components	Material
1	Base	Polyamide with fiberglass
2	O- ring	NBR
3	Body	Polyamide with fiberglass
4	Kinetic float	Polypropylene
5	Automatic seal	EPDM
6	Automatic float	Polyamide with fiberglass
7	Kinetic seal	EPDM

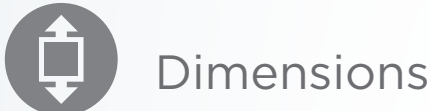

Dimensions	2"
H	245 mm
W	103 mm
D	BSP 2" male
A	855 mm ²
Weight	0,716 kg

Service pressure: PN16

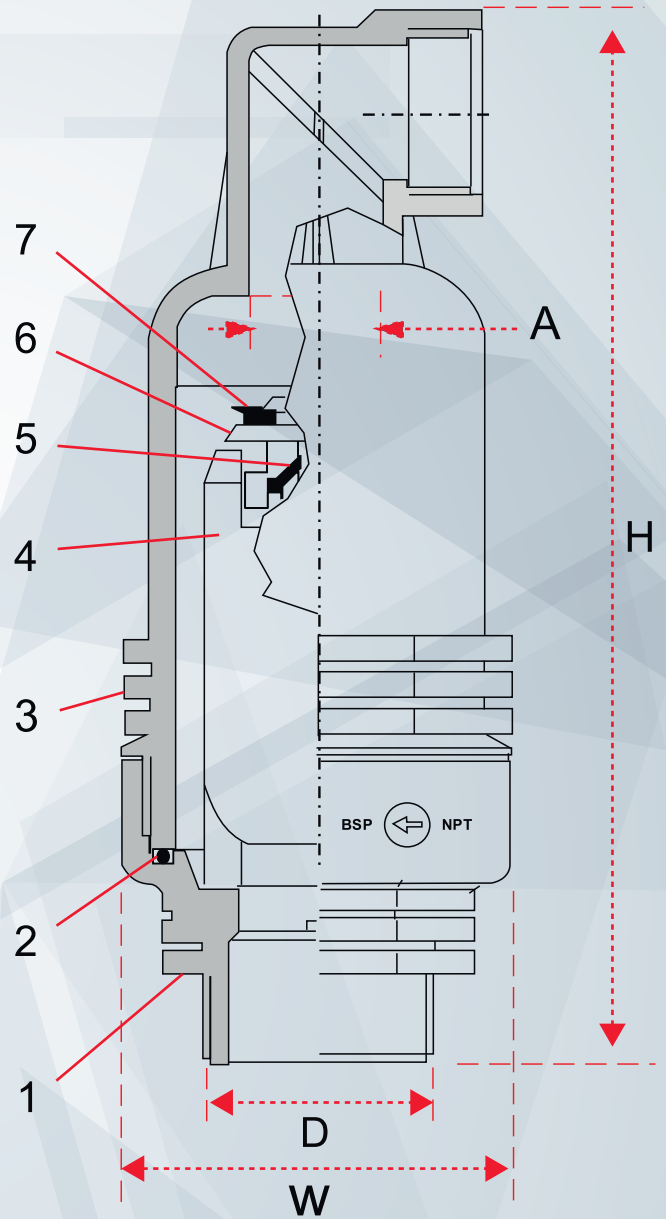

Air Discharge

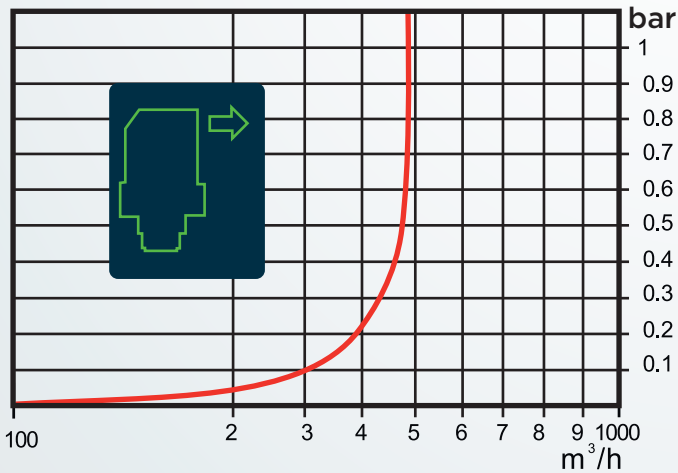

Air intake

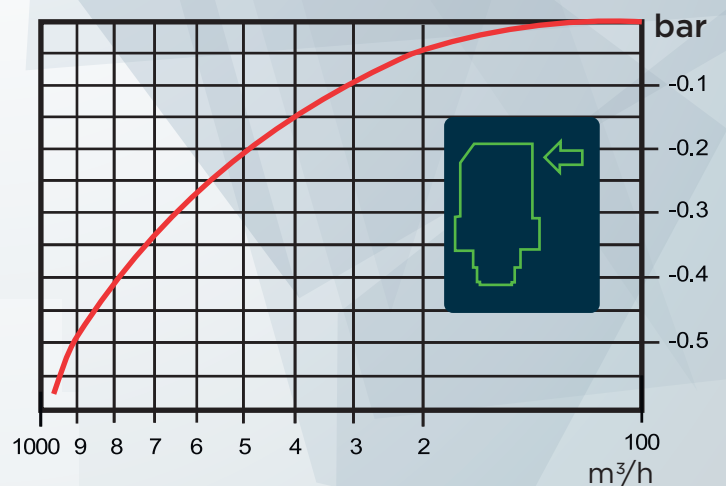

AUTOMATIC AIR RELEASE VALVE

Plastic series

WHEN WATER COUNTS

www.fluidflo.com.au

T: +61 3 9290 9813
info@fluidflo.com.au
www.fluidflo.com.au

