

BRAEMER MODELS

GREAT BRITISH MODEL KITS



**1:32 KTwo Roadeo
Compact and Push Trailer**

1:32 KTwo Rodeo

Compact and Push Trailer

CLEAN ALL RESIN PARTS IN WARM SOAPY WATER

The silicone release agent used in the casting process will react with paint, it must be thoroughly cleaned off before painting.

This is a guide to using the kit. Care should be taken at each stage to make sure the model is going together correctly and any alterations that are not in the instructions should be carried out.

Glue: Recommended glue is a good quality super glue such as Gorilla Super Glue. I use the Blue Lid Gorilla Super Glue which is readily available from most hardware stores including B&Q and Screwfix. It provides a strong bond, the acrylic around the bond will snap before the bond breaks.

Paint: The instructions will suggest the best point to paint components. A good quality automotive primer or plastic primer followed by automotive acrylic is recommended. Brands such as Hycote or Halfords are likely to be problem free and provide a good finish to your model while being readily available.

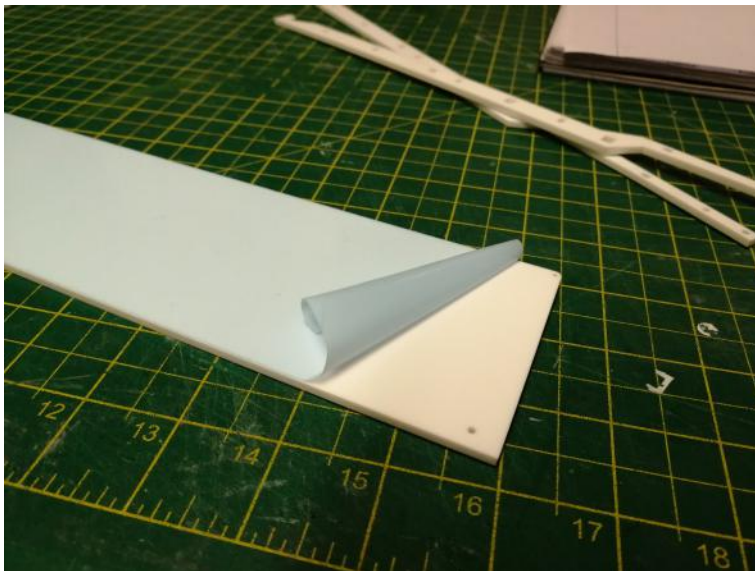

Not KTwo parts pictured, sorry!

Step 1: To start with I recommend cleaning the resin parts (wheels and tyres) in a strong washing up liquid solution. Remove any flash from the resin parts too, this is excess resin left over from the casting process where resin is poured into the mould.

Then remove the plastic backing from all acrylic parts and sand back the surface with a fine grit sand paper 220 grit or less. The laser cutting process causes a slight raised edge on most parts that will inhibit strong adhesion. By sanding these edges off a stronger glued bond can be made and the surface of the plastic is improved for paint adhesion. Sharp edges can give a thin paint application that shows as white edges in the final paint.

It is important to take care when sanding as Acrylic is a brittle material and can easily snap. If something does break simply line up the crack lines and glue back together, leave 24hrs before using the part again so the glue can set firmly. The same applies to any resin parts.

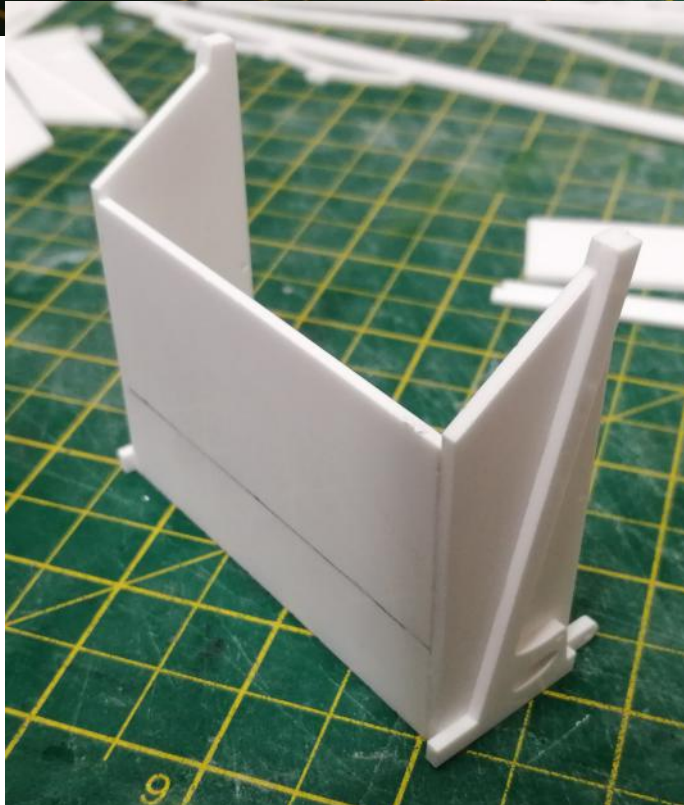

Step 2: To get use to the material and kit I recommend starting with the rear door. To begin glue the side detail to the sides (Prt No.11). Repeat for the opposite side checking that they are oriented opposing ways.

Step 3: Connect the two sides using Prt No. 12. Ensure the joint is exactly 90 degrees and the edge of No.12 glues to the face of No.11

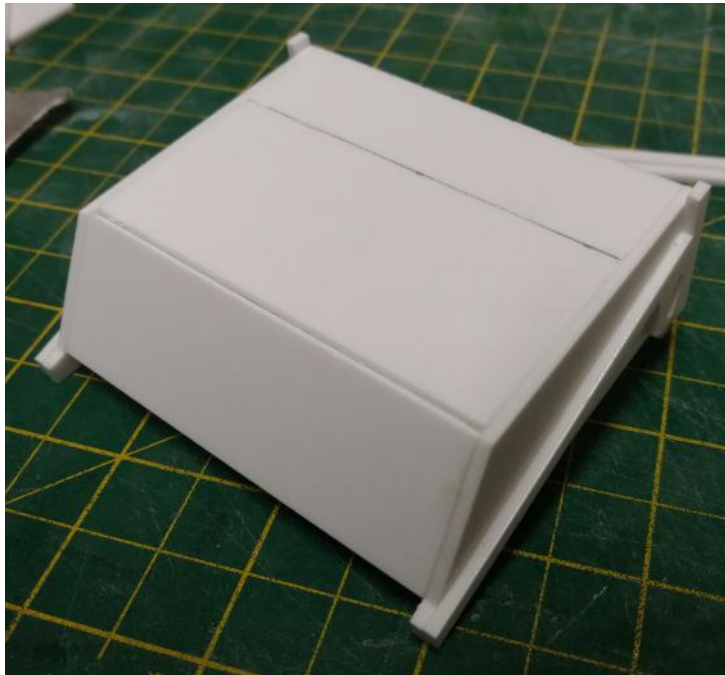

Step 4: Glue Prt No.16 to the base of the door assembly as pictured. Line up the top edge with the corner of No.11.



Step 5: Glue Prt 14 and 2x Prt 15 to the back of Prt 12. Line 14 up with the top between the two side details. Line the first 15 up with the top edge 18mm from the top of 12 and the second 15 up with the bottom covering the gap between 12 and 16.



Step 6: Glue the 2x Prt 17 to the bottom of the door assembly staggered to keep in line with the base.

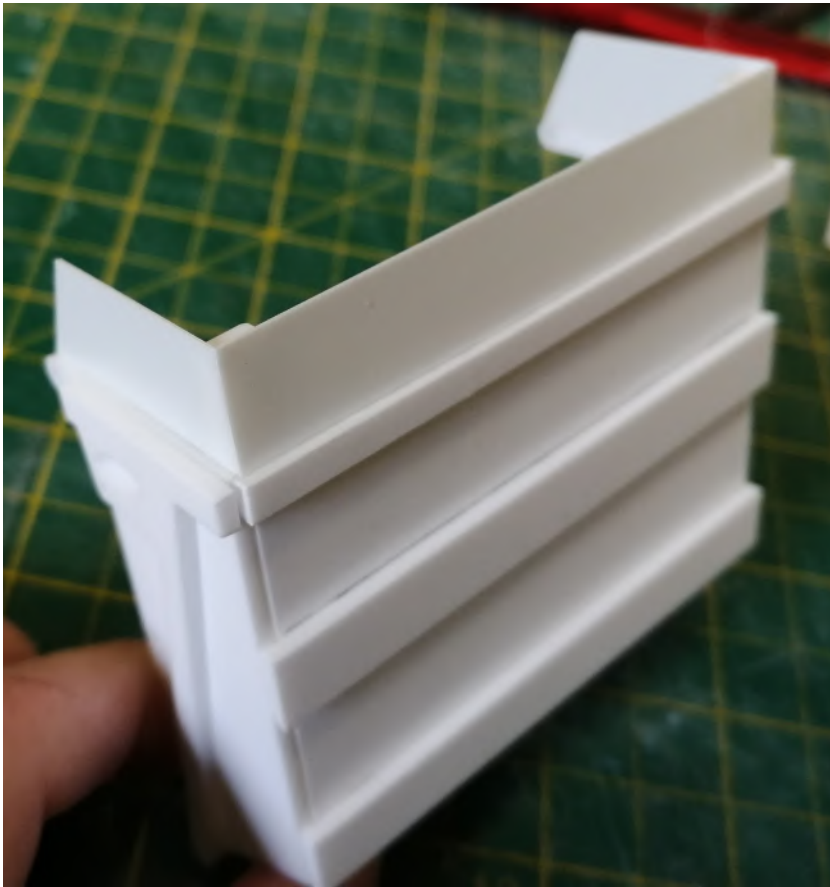

Step 7: Glue the thin plasticard extensions to the top of the door as pictured. Use two of the small 3mm slips to support the corners.

This completes the door assembly, it can be put to the side until ready to paint.

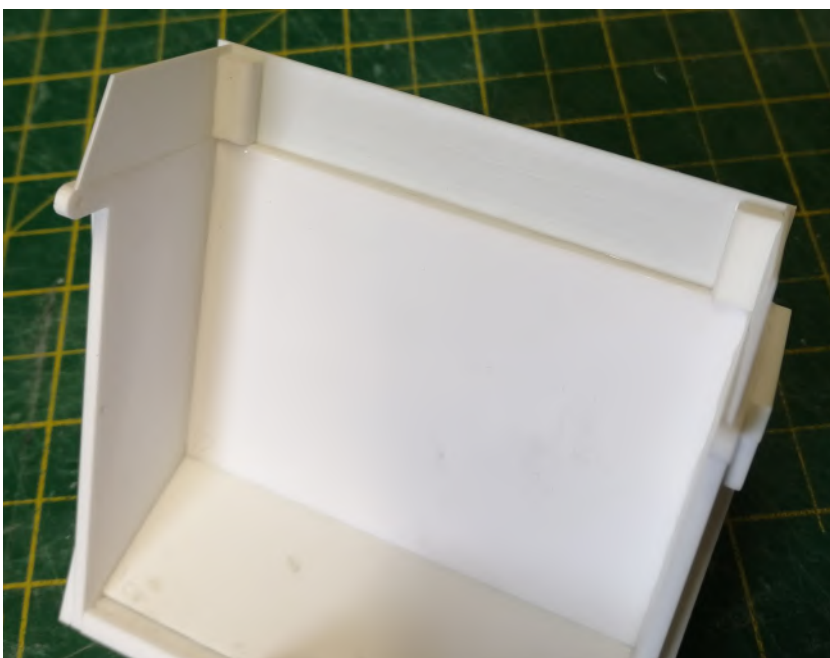

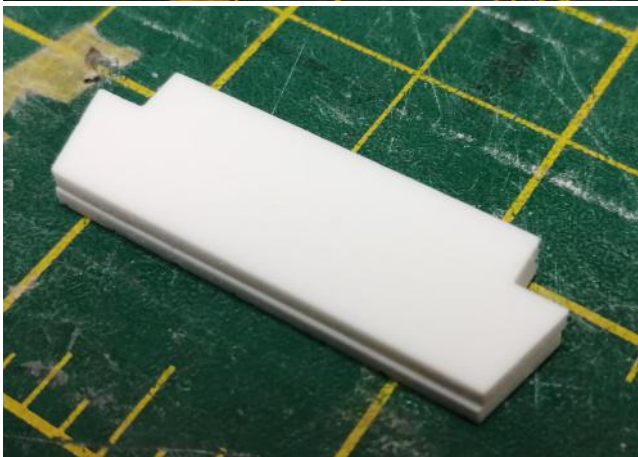

Step 8: The chassis can be constructed next. To begin with glue Prt No. 18 and 19 together, ensuring that the axle holes align. Repeat for the other side of the chassis but making sure the join is mirrored.

Step 9: Glue the 2x Prt 21 back to back to make the drawbar hanger.

Step 10: Glue 3x No. 20 into the chassis rail as pictured ensuring a 90 degree angle, the drawbar bracket can also be glued into the designated slot.



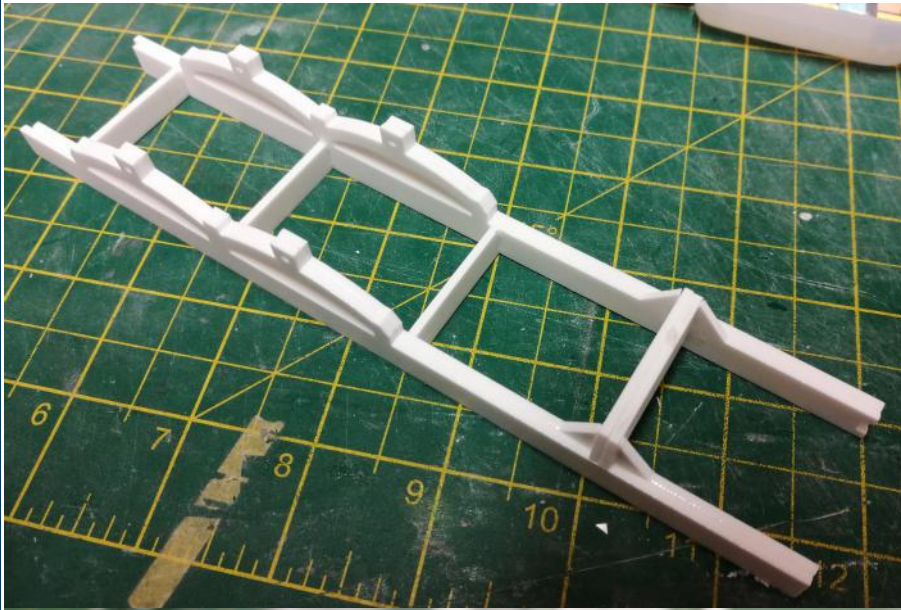

Step 11: Glue the opposite chassis rail in place as pictured. The fourth No.20 can be glued to the front of the chassis in its slot as well.

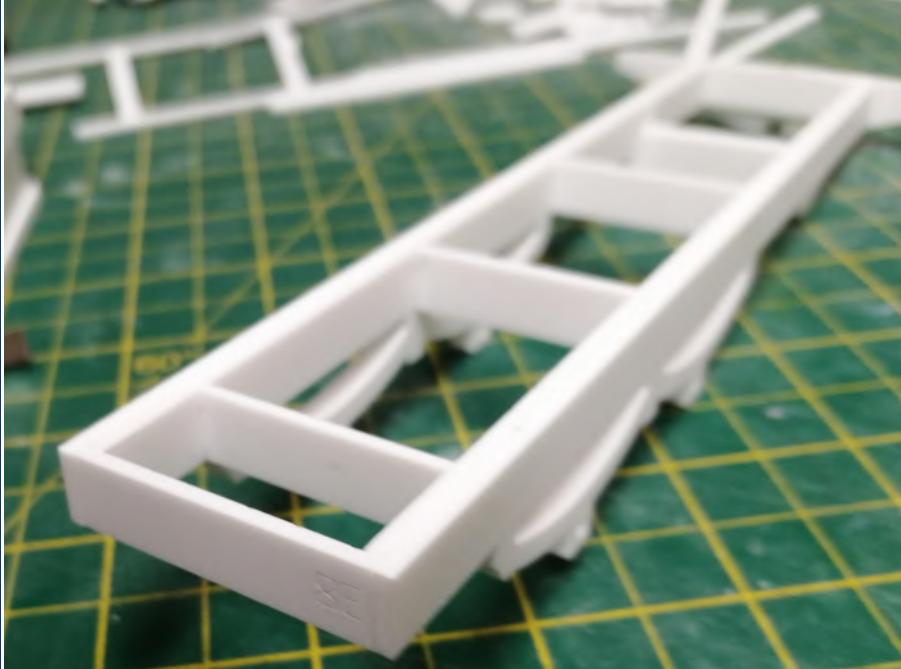

Step 12: Prt 38 glues into the back of the chassis and Prt 37 glues onto 38.

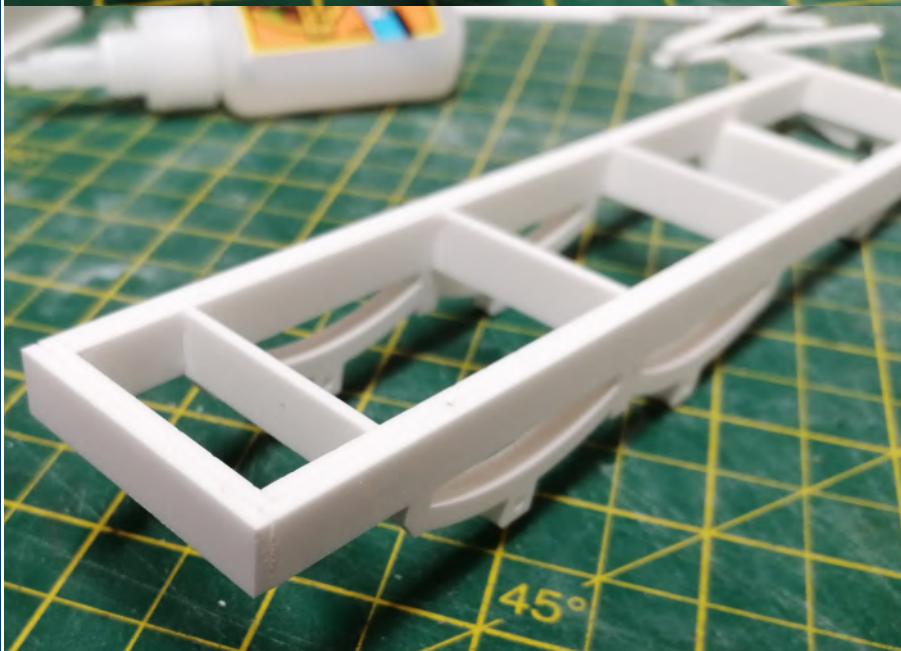

Step 12B: Side note as it was forgotten in the prototype. The bumper bar should be glued on at this point as photographed.

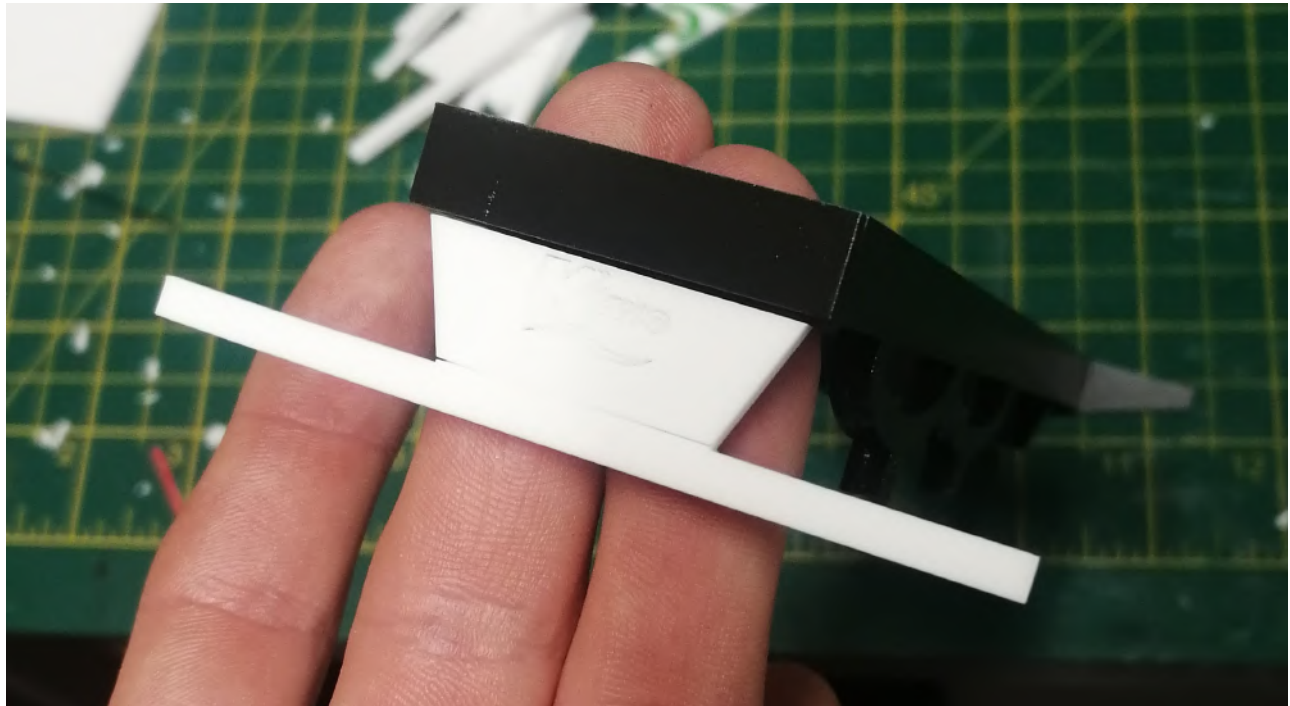

BRAEMERMODELSBRAEMERMODELSBRAEMERMODELSBRAEMERMODELSBRAEMERMODELSBRAEMERMODELSBRAEMERMODELSBRAEMERMODELSBRAEMERMODELSBRAEMERMODELS

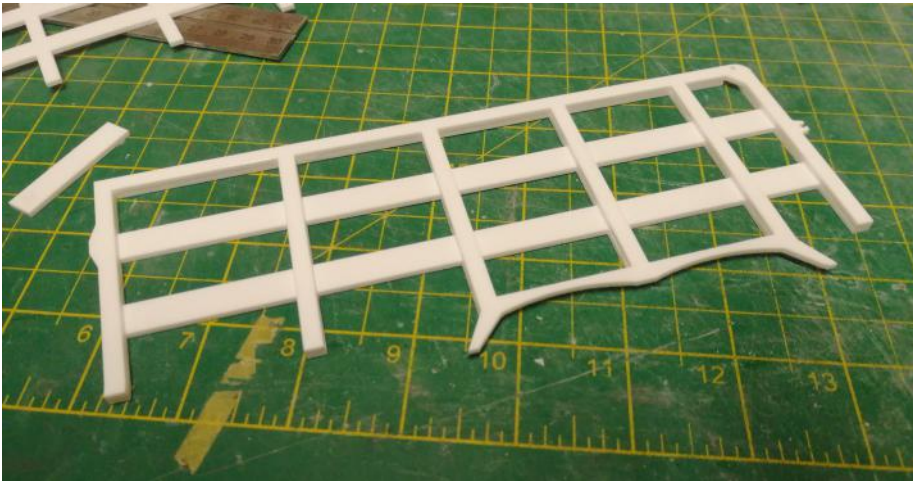

Step 16: Constructing the body begins by making the sides. Start by gluing the inner and outer sides together as pictured. Repeat for the opposite side ensuring the join is mirrored.

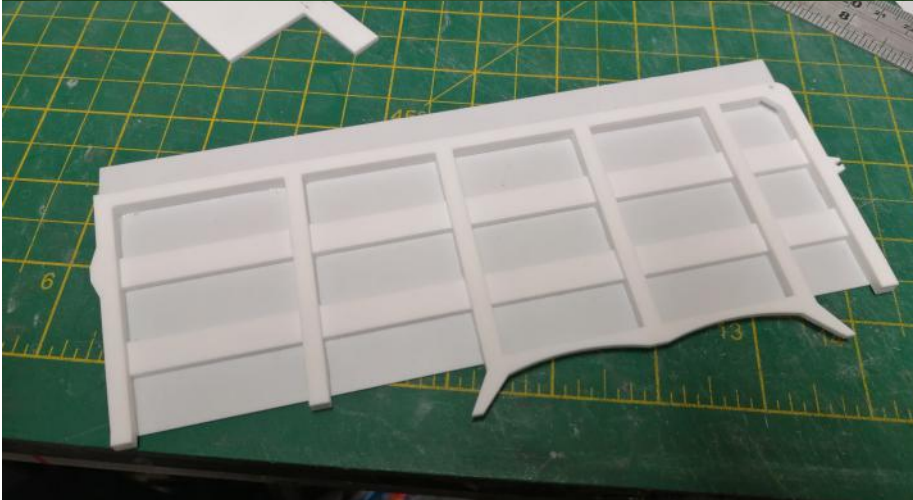

Step 17: Glue the sheet side to the acrylic parts. Draw a line 12mm from the top line of the sheet and align the top of the acrylic with the line. The sheet should fit with a 2mm gap at the bottom of the acrylic.

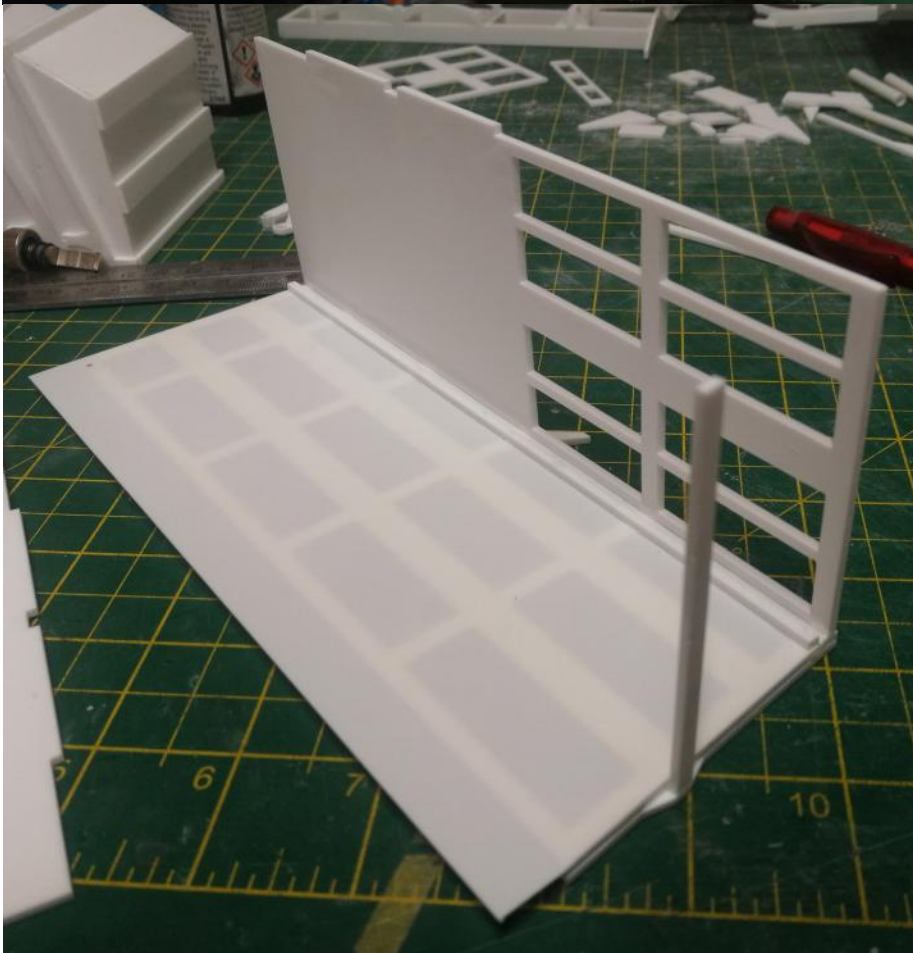

Step 18: Glue the base plate to the bottom of the side as pictured. The edge of the base should glue to the 6 ribs and the edge of the mudguards where it is slotted. Ensure the attachment is at 90 degrees. From the corner draw a parallel line 2.5mm up and glue the long short strip above this line. The ejector floor runs in the slot created. Glue prt 39 to the front of the trailer in the slot at 90 degrees to the side.

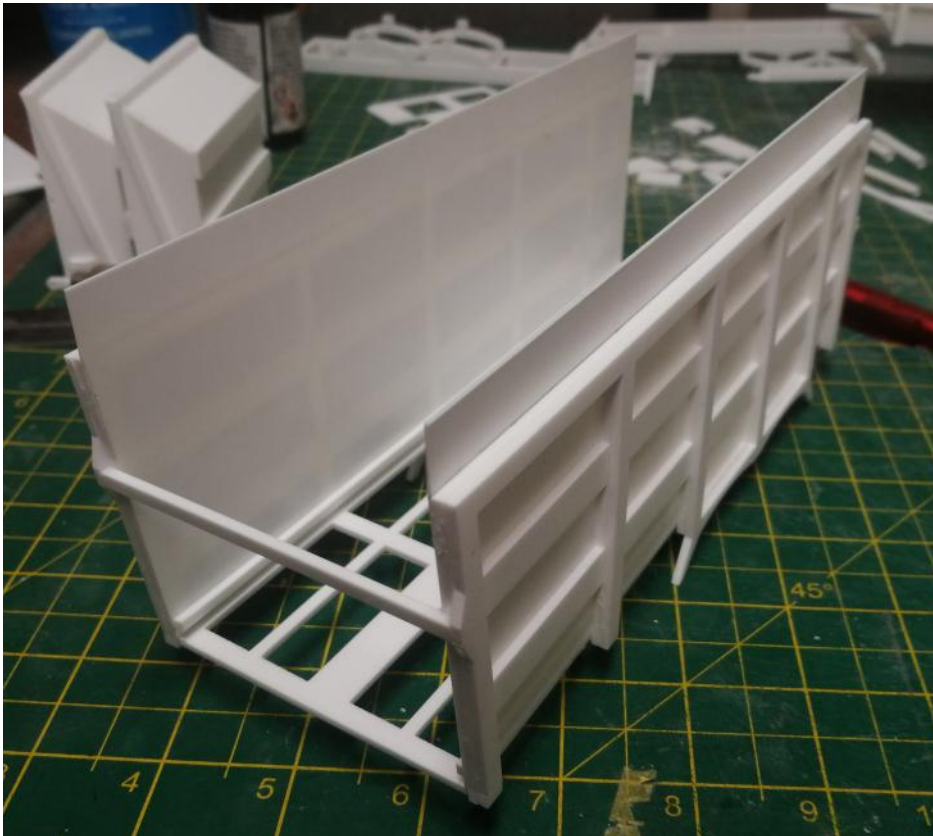

Step 19: Glue the second side to the base plate as pictured. It also needs the long thin strip gluing to this side as well 2.5 mm from the base. Double check that the ejector floor (prt 25) slides in the slot.

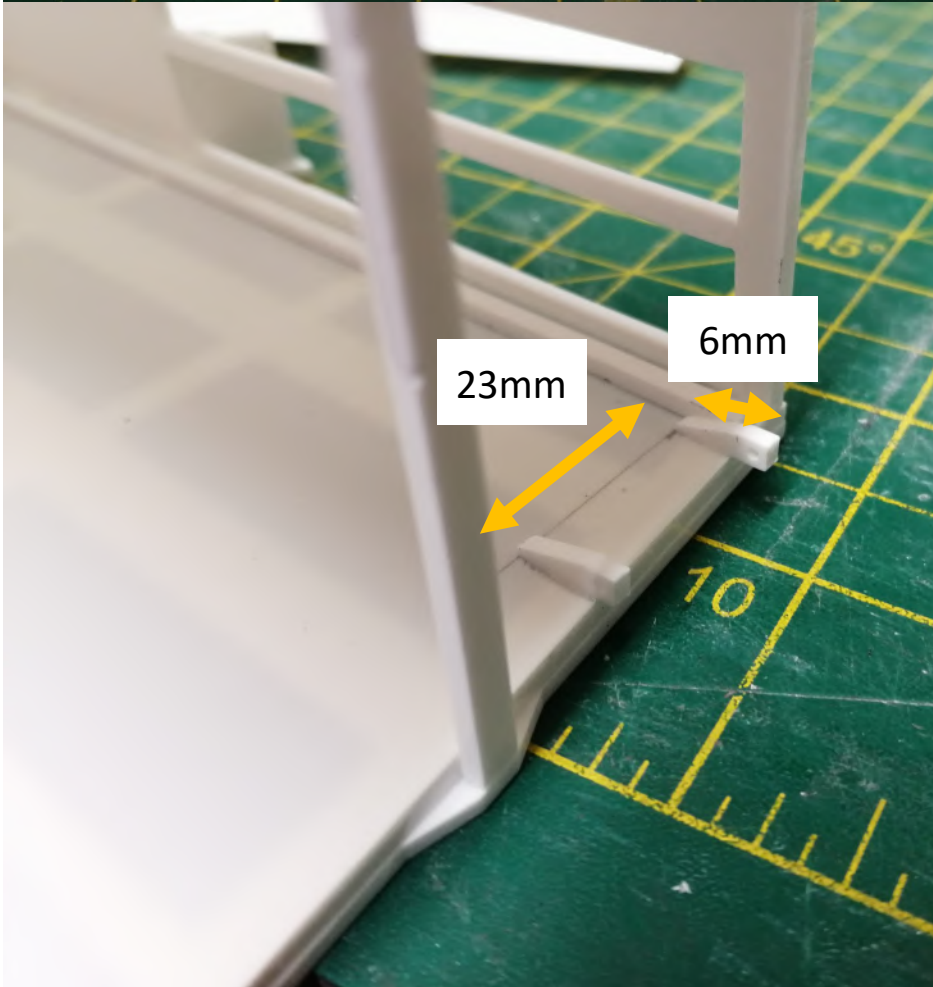

Step 20: Two hinges are required to hold the hydraulic line support bar (prt 44). Draw a line 6mm back from the point where the long thin strip reaches the front. Draw a second line 2.3mm up from the strip. The two hinges sit in the rectangle created as pictured.

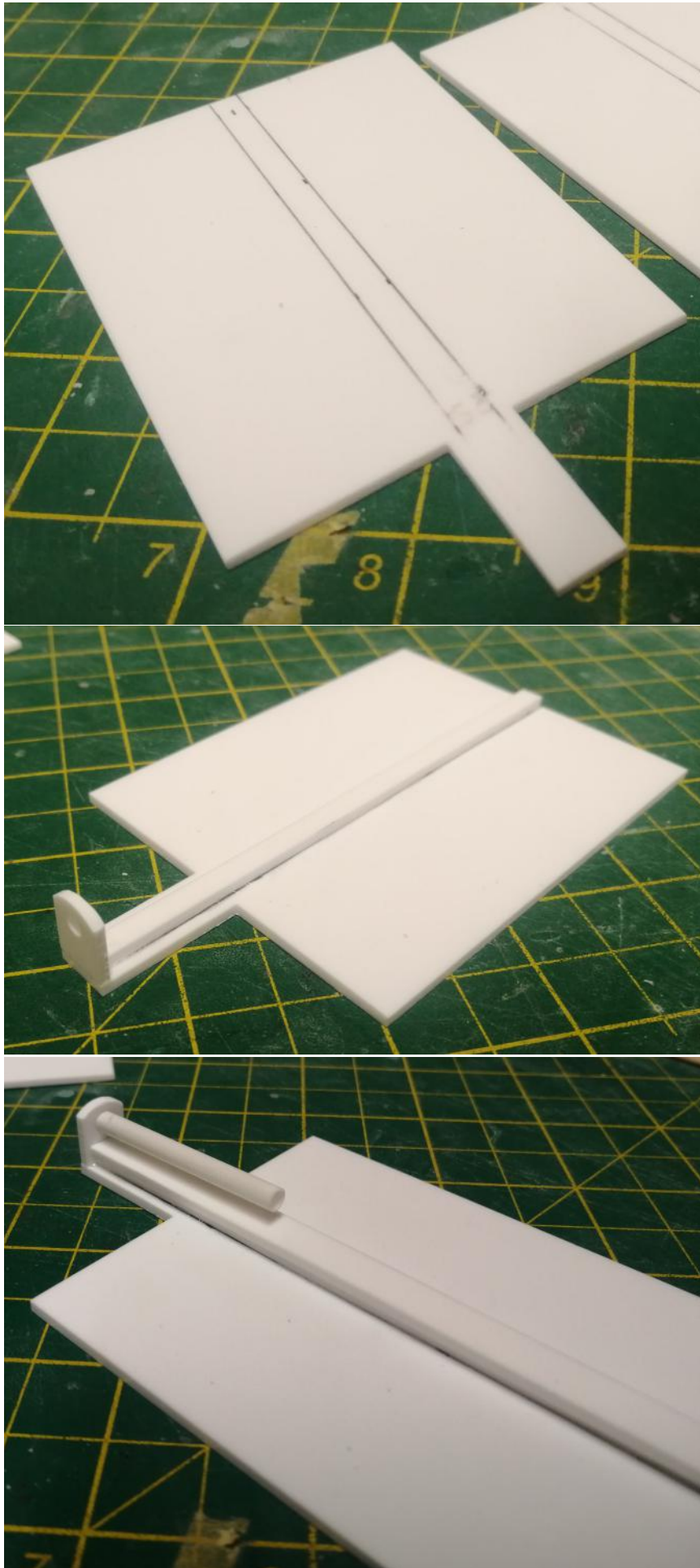

Step 21: The ejector floor is constructed from prt 25. Begin by drawing a 5mm wide line along the centre of the part as illustrated. Glue part 26 to the floor butting up to the flat edge. Glue part 27 to the front of 26 on the long protrusion as illustrated. Glue part 31 onto the top of 26 centrally. Finally glue one of the small diameter tubes into the hole in part 21. The ejector bed is now complete.

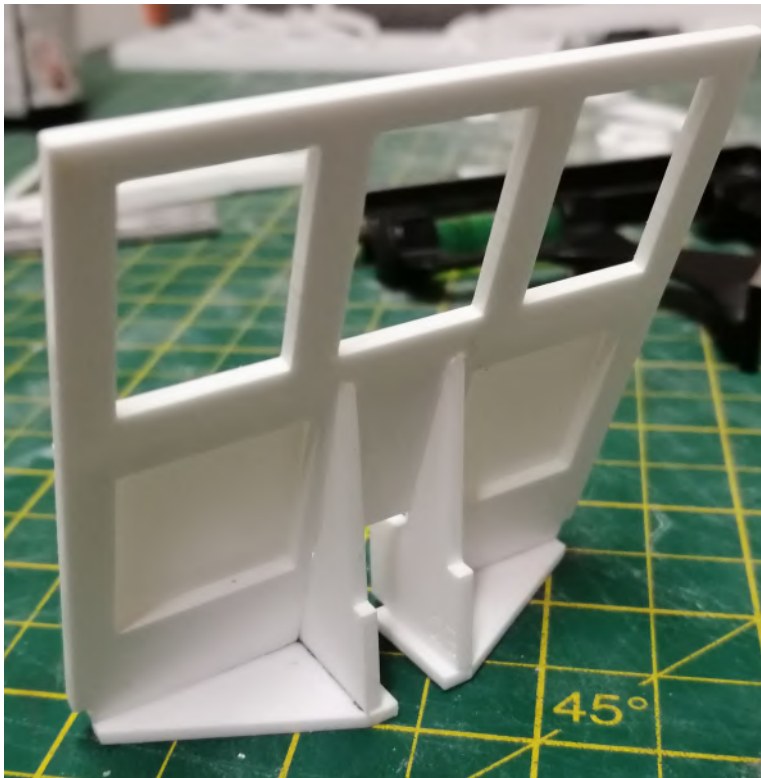

Step 24: Glue the two mounts to the headboard. They glue as pictured butting up against the slope of 23 and the edge of 32. The plated side of the headboard should be on the opposite side of the mounts.

Step 25: Glue part 28 to the back end of 23's and add 34 to the top to fill the gap as pictured.

Step 26: Glue part 35 to the front of 23's and the second small diameter tube into the hole in 28.

Step 27: Cut the mesh panel to size and glue over the open windows of the headboard. While self adhesive it would help to use abit of extra glue.



Step 28: Glue the four mudguards into place as pictured. Each mudguard is part 41 and glues at an angle. You may wish to sand one edge of 41 at an angle to improve the bonding and aesthetic.

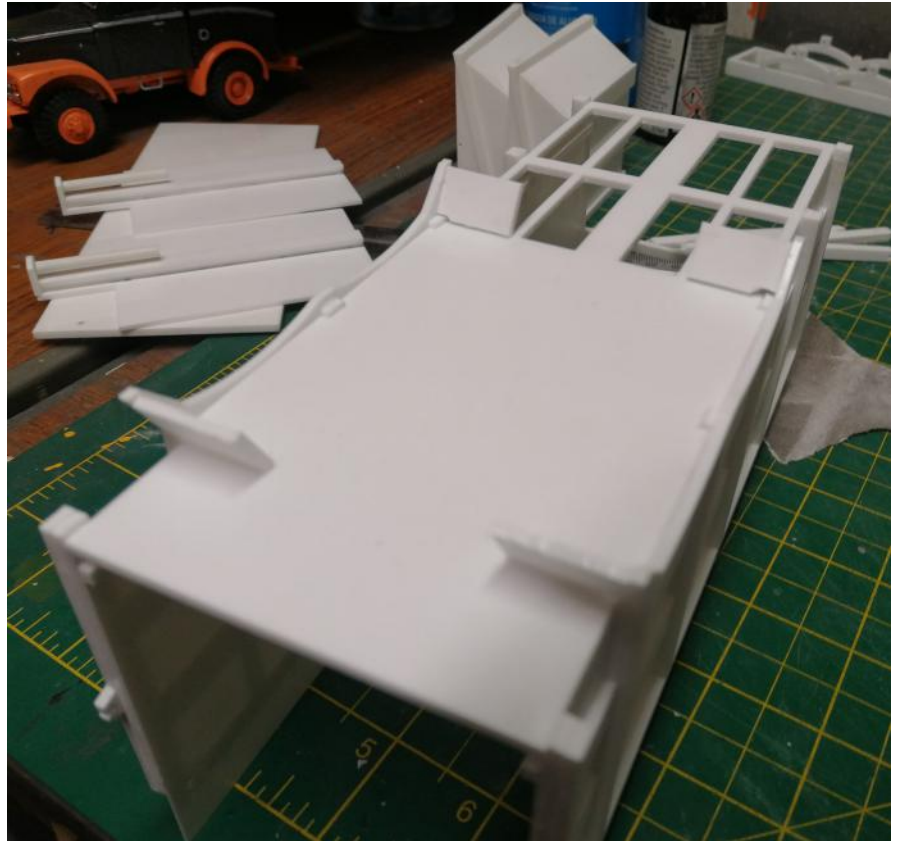

Step 29: The two hinges are glued onto the right hand inner side of the body. The hinges are glued in the dimensions shown below.

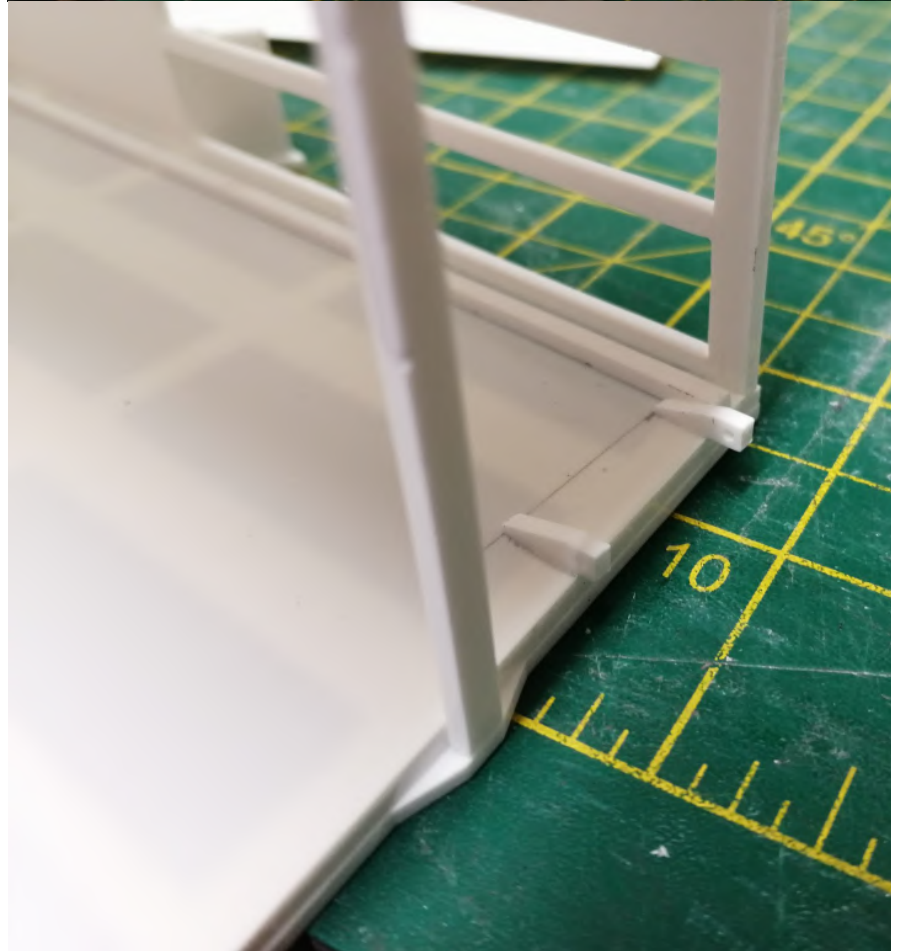
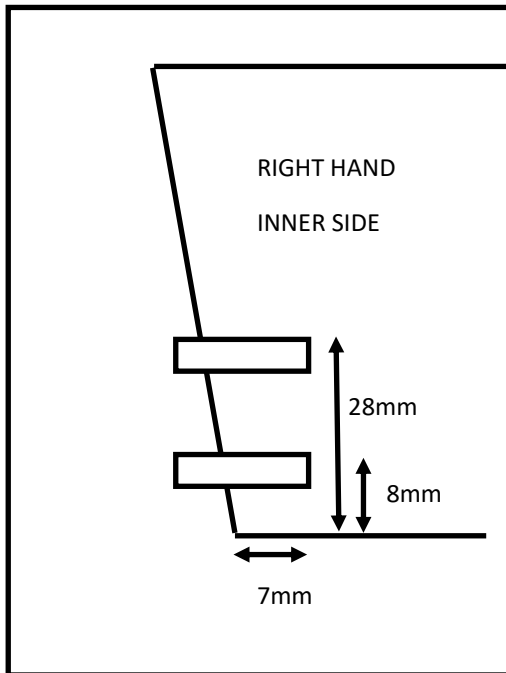

Step 30: The two large diameter tubes glue side to side as pictured making the central ram.





Step 31: The parts are now ready for paint. I would recommend starting with a plastic primer, I used Halfords Grey Plastic Primer but a red primer may also be suitable. This helps bond to the acrylic parts while also levelling everything to the same colour. Once the primer is dry I have used an automotive paint. The body is painted in Halfords Fiat Red Orange and the chassis, ejector parts and doors in Halfords Volvo Dark Grey 228. These are not an exact match but make for an affordable option. The official colours are described as Poppy Red and Fendt Dark Grey so if you have a dealership near by they may be able to help. Once dry details can be brush painted in such as painting the ram ends in silver.

Step 28: The ejector headboard slides onto the ejector floor. The ram cylinders slide over both ram rods. The whole assembly then slides into the body.



Step 40: Your model is now complete and ready to enjoy!



BRAEMERMODELSBRAEMERMODELSBRAEMERMODELSBRAEMERMODELSBRAEMERMODELSBRAEMERMODELSBRAEMERMODELSBRAEMERMODELSBRAEMERMODELSBRAEMERMODELS