

138 mm

210 mm



**SNOW+ Automatic Pet Feeder**  
**Instruction Manual**

**PS-020**



Thank you for choosing this PetSnowy product. To use this product correctly and safely, please read and understand this instruction manual carefully and thoroughly before use and keep it for future reference. Failure to do so may result in loss of pets and/or damage to the product. Please note that PetSnowy is not responsible for any failure caused by misuse, modification by anyone other than the Company, or improper installation or maintenance. PetSnowy reserves the right to interpret and modify this manual.



## **CATALOGUE**

1. SAFETY INSTRUCTIONS .....	2
2. PRODUCT STRUCTURE .....	3
3. FEATURES .....	4
4. INSTALLATION .....	5-7
5. APP DOWNLOAD .....	7-13
6. OPERATION .....	14-16
7. FCC STATEMENT .....	16
8. TECHNICAL SPECIFICATIONS .....	17
9. WARRANTY CARD .....	17

## SAFETY INSTRUCTIONS

1. Please read and understand this instruction manual carefully and thoroughly before use.
2. Keep the device away from high temperature and humidity and direct sunlight for indoor use only.
3. The device must be placed on a flat and hard ground. Do not place the device on a tilted or unstable surface.
4. This device can only be used for feeding cats and small dogs. Do not use it for any other purposes.
5. No other items can be placed on the device. People are not allowed to sit on the device.
6. This device is suitable for dry pet food sized 0.2 - 0.59 inch in diameter only. Canned food, liquid food, or other semi finished food should not be used
7. Children are prohibited from operating the product alone. Children may only operate the device under adult supervision.
8. Please check and clean the device regularly, removing all food residue, to avoid the growth of mildew and bacteria.
9. Do not put your hand into the food outlet and food container to avoid accidental injury when the device is operating.
10. Please keep pets from jostling the device. If the device is knocked over, the pet food may spill out.
11. Please do not allow your pet to bite or chew the cord of the adapter.
12. This device is not waterproof. Only the food container, stainless steel feeding tray, and feeding tray base can be washed with water. Keep other parts of the device away from water.
13. Before cleaning the device, disconnect the product from the power supply. Do not plug in or remove plug with wet hands to avoid shock.
14. To clean the device's surface, only wipe it with a soft cloth dipped in water. Do not use abrasives, organic solvents, or corrosive solvents to clean the device's surface.
15. Only AA-size batteries can be used for this device. Please make sure the AA batteries are installed with the correct polarity.
16. Rechargeable batteries cannot be used. Old and new batteries cannot be mixed.
17. If the device is not used for a long time, remove the batteries to avoid battery fluid leakage and damage to the device.
18. Follow the local laws to dispose of the used batteries. Do not throw them away randomly so as to avoid environmental pollution.
19. Non-professionals must not attempt to repair, transform, or disassemble this device.

## PRODUCT STRUCTURE

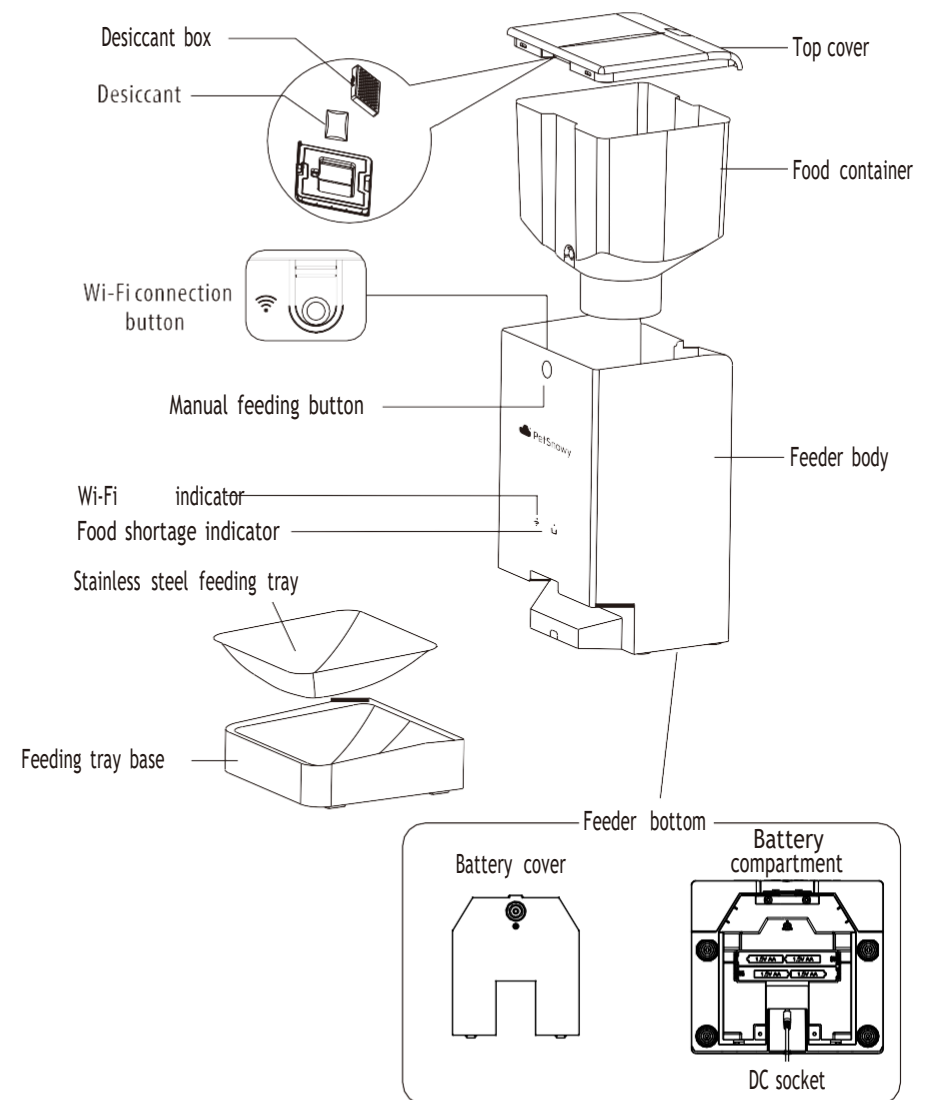

## FEATURES

- **Simple operation - one key to feed**

Press and hold the feeding button to feed manually

- **Regular and quantitative healthy feeding**

10 feeding schedules can be set to ensure regular and quantitative healthy feeding

- **Dual power supply - no need to worry about power blackouts**

Powered by both battery and power adapter to ensure continuous food supply

- **Moisture-proof design to keep food fresh**

Food container and food outlet seals are designed to ensure that food is protected from moisture

- **Power-off memory - no data lost**

Once set, the data is permanently saved

- **Anti-clogging design**

Food outlet infrared detection to prevent food from stacking and causing transmission mechanism damage

- **Remaining food detection - timely reminder**

Automatic warning when food level in the food container is insufficient

- **Feeding records can be searched**

The app saves the feeding records, which can be searched at any time

- **Simple assembly and disassembly for convenient cleaning**

Food container and feeding tray can be disassembled for cleaning

- **Stable and not easy to tilt**

Overall center of gravity downward, making it difficult to tilt

- **High-quality stainless steel feeding tray**

Feeding tray made of food-grade, high-quality 304 stainless steel material is corrosion-resistant and easy to clean.

## INSTALLATION

1. Load 4 AA batteries correctly according to the battery polarity mark.

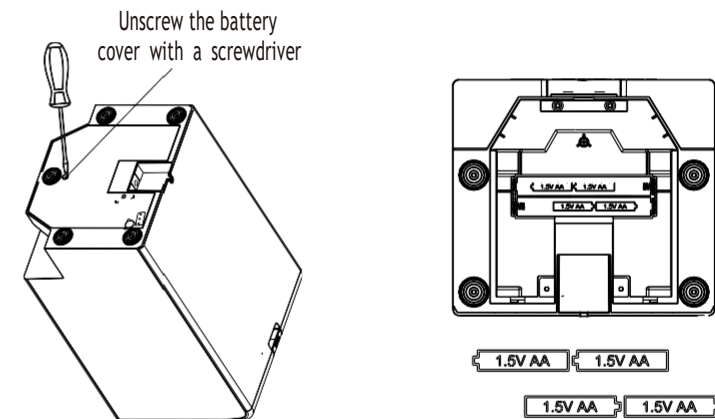

2. Insert the adapter output plug into the DC socket of the feeder, then plug the adapter into the main socket.

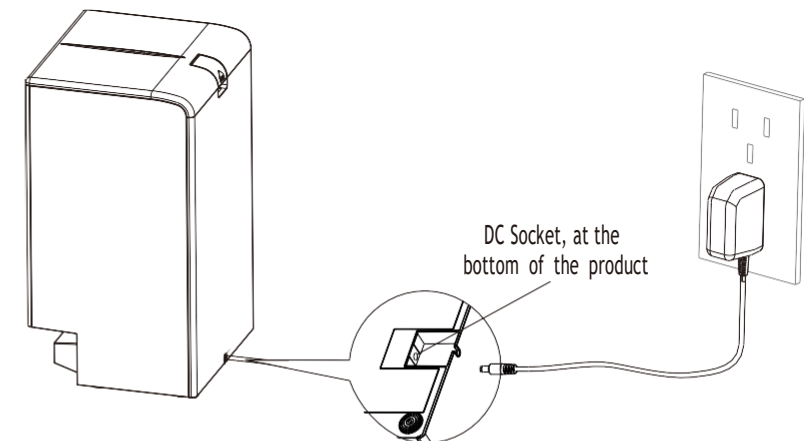

**Tip:** It is recommended to use both battery and adapter for power supply. In case of power failure, the feeder will automatically switch to battery power supply to ensure continuous food supply.

3. Place the stainless steel feeding tray on the feeding tray base, and then attach it to the feeder body.

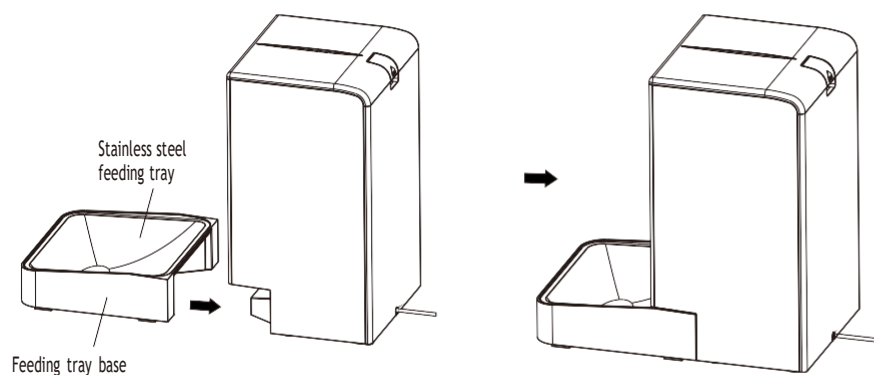

4. Press the latch to open the top cover; tear the sealed bag to take out the desiccant, then put it in the desiccant box, then fasten the desiccant box into the top cover.

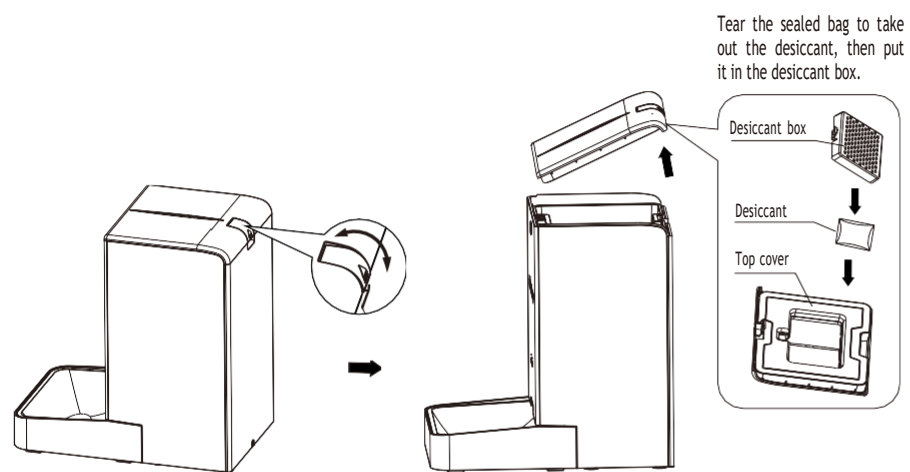

5. Pour appropriate amount of pet food into the food container, put the top cover on, and start to use.

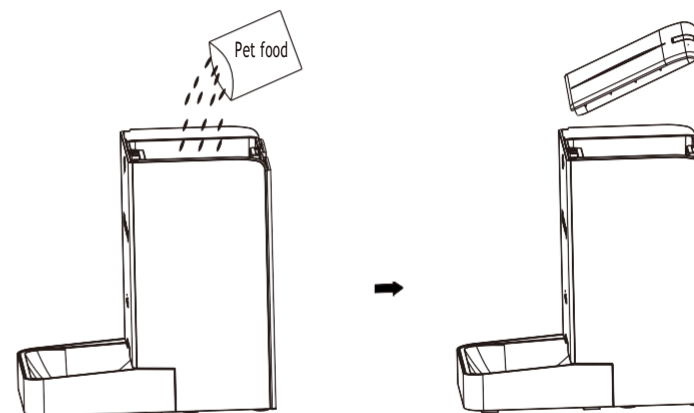

### APP DOWNLOAD

1. Download and install the PetSnowy app from the Apple or Android app store, or scan the QR code to download and install the app.



2. Connect your phone to a Wi-Fi hotspot and turn on Bluetooth.



3. When adding the device for the first time, please put the device as close as possible to the router. (This device is only compatible with 2.4 Ghz routers. If your router is a 5 Ghz or 2.4 Ghz dual band router, please set it to be 2.4 Ghz.

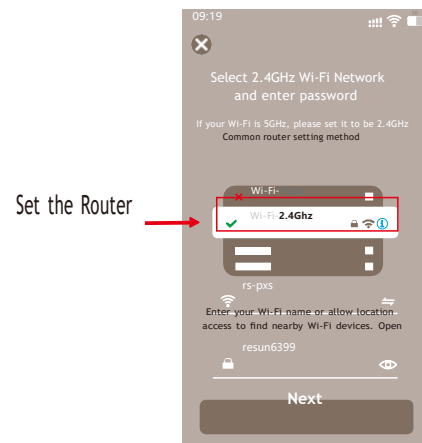

4. Open the app, click "+" in the upper right corner of the home page, then click "Add Device" to add the device.

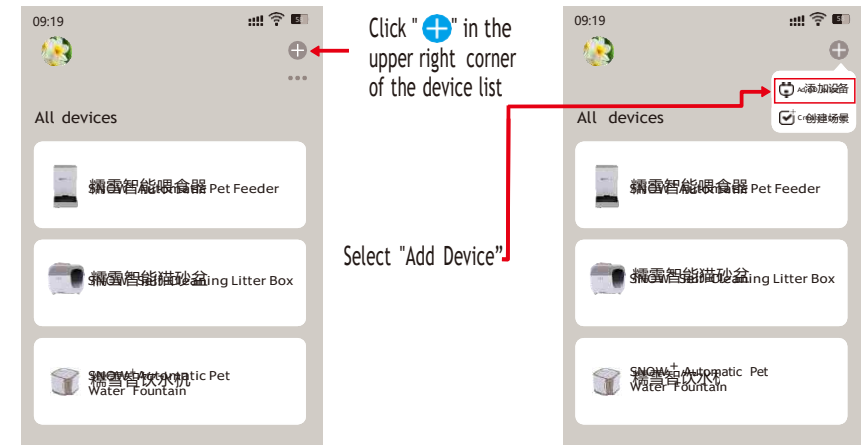

5. If the smart devices nearby have been detected, select "Pet Feeder" from the list of detected devices and follow the app's instructions to add the device.

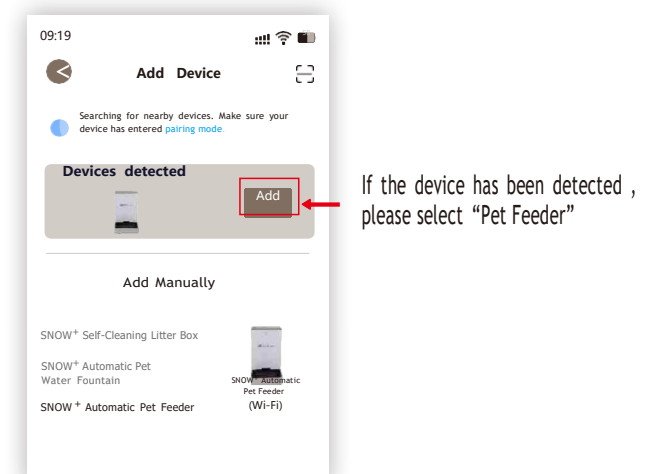

5-1. If no device is detected, manually select "Pet Feeder" and add the device according to the app's instructions.

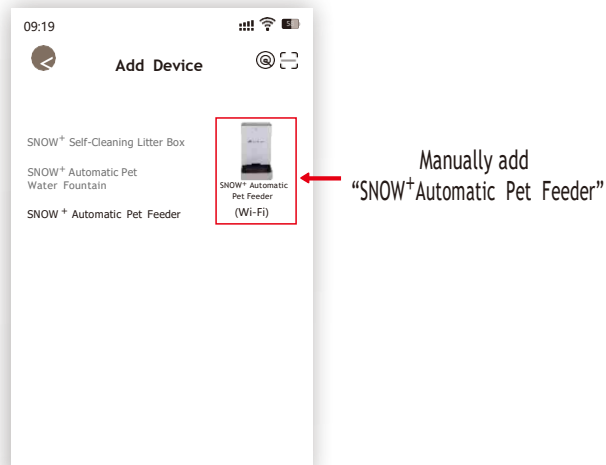

5-2. Press and hold the Wi-Fi connection button for more than 5 seconds until the Wi-Fi indicator light flashes. Then click "Next".

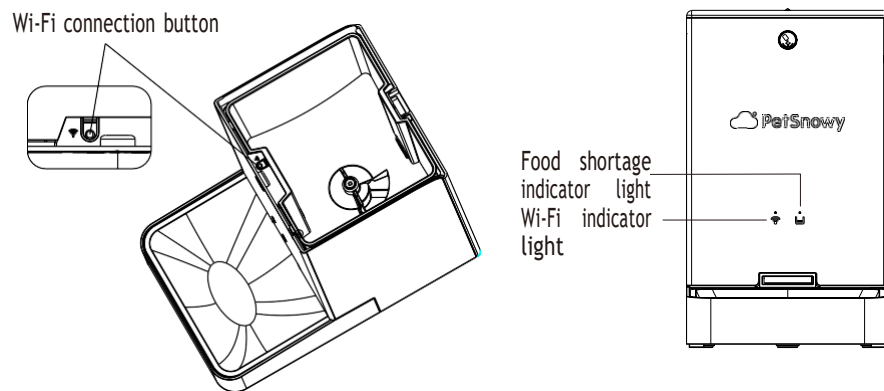

5-3. Please confirm the blinking frequency of the Wi-Fi indicator light (about once every 1 second). Please click "Confirm the Wi-Fi indicator is blinking rapidly" and click "Next".

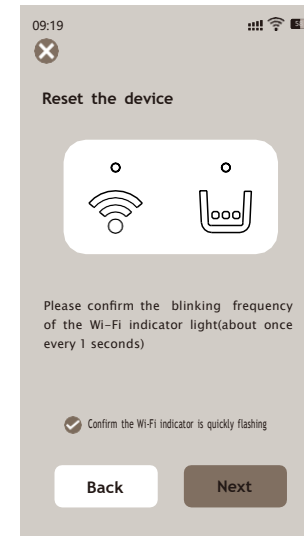

5-3 Confirm the Wi-Fi indicator is quickly flashing.

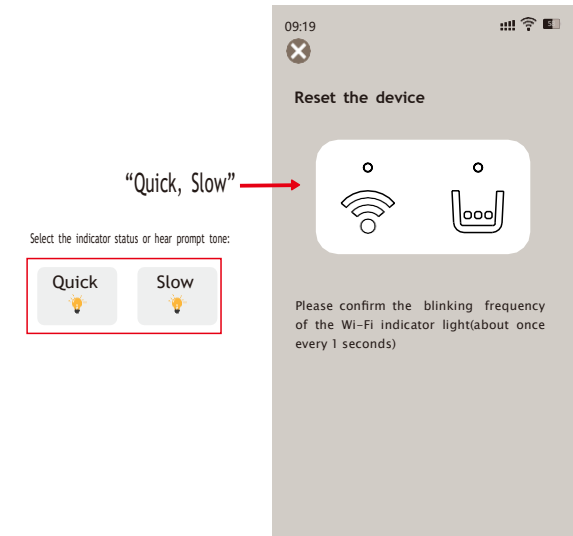

5-4

5-4. Select the pairing mode according to the blinking frequency of the Wi-Fi indicator light. **Note:** The default pairing mode is Bluetooth mode (Wi-Fi indicator light flashes quickly). Long-press the Wi-Fi connection button on the device to switch to AP mode (Wi-Fi indicator light flashes slowly) or EZ mode (Wi-Fi indicator light flashes quickly).  
5-5. Confirm the hotspot, enter the password, and click "Next".

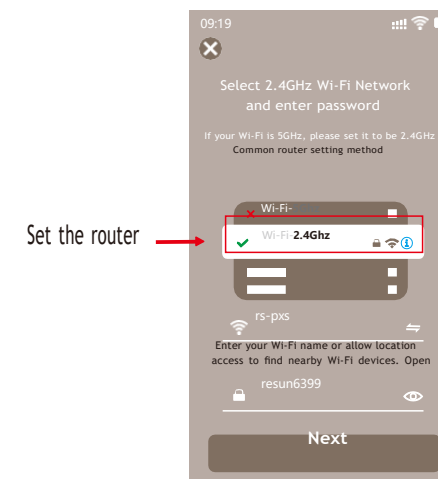

5-6. The app automatically connects to the device. Click " " and click "Done" in the upper right corner after the device is successfully added.

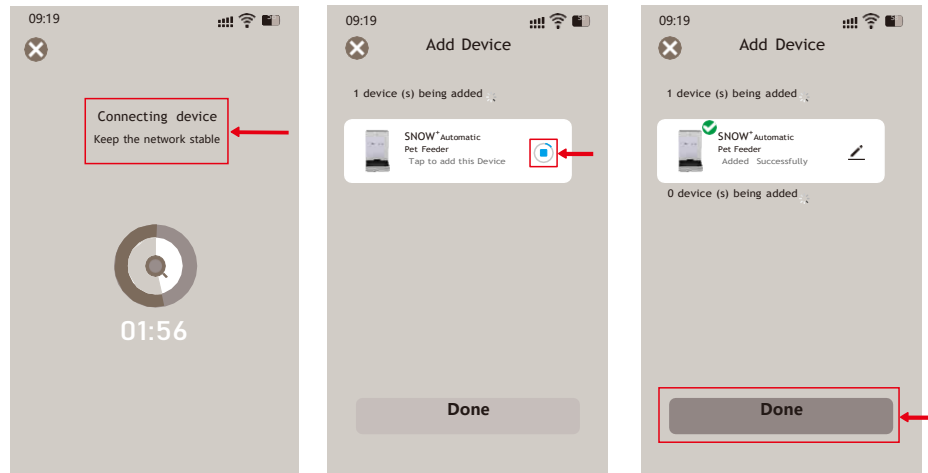

Automatically connect device

Click " "

Click "Done" in the upper right corner

6. If the device fails to be added, add the device again according to the possible causes prompted by the app.

7. Set the device name.

7-1. Click the " " in the upper right corner.

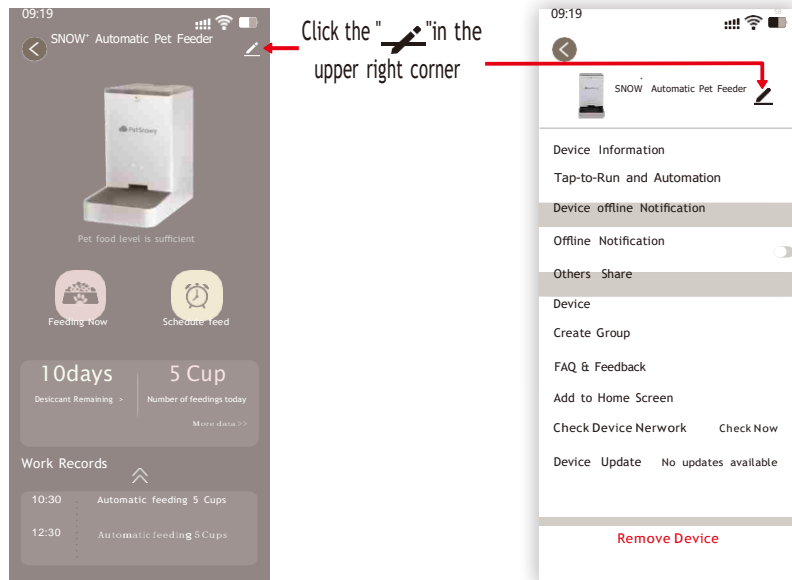

Click the " " in the upper right corner

7-2. Rename it, and save it.

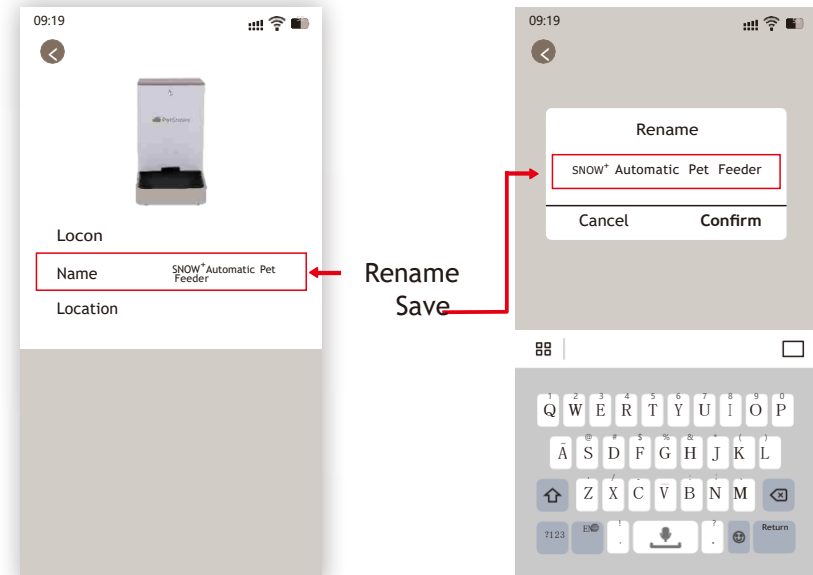

Rename Save

8. Go to the app's home page and click the successfully added device to enter the device control page. You can select the "Feeding Now" function or "Schedule Feed". The Pet Feeder will perform the feeding function according to the "Schedule Feed" setting. More app functions are waiting to be discovered.



Device control page



## OPERATION

### Local Functions

- Press and hold the "Feeding button" to perform the local manual feeding function.
- When there is not enough pet food in the food container, the food shortage indicator light flashes to remind you to add food.
- When the device is offline, the Wi-Fi indicator light flashes. When the device is online, the Wi-Fi indicator light will be constantly on.

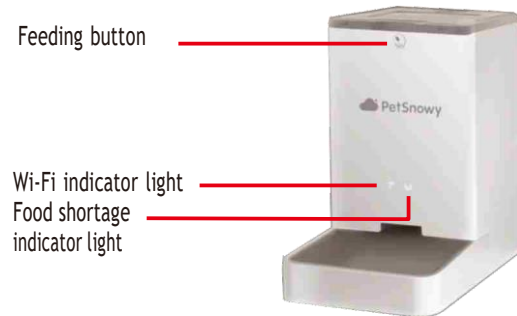

### App Function

#### • Feeding Now

Click the "Feeding Now" button in the app, set the feed amount on the Feeding Amount interface, and click "Feeding Now" to perform the Feeding Now function.



#### • Regular feeding

The feeding plan can be set based on actual need. The device will automatically perform the feeding function at the set time and with the set amount. (Maximum 10 feeding schedules can be set.)

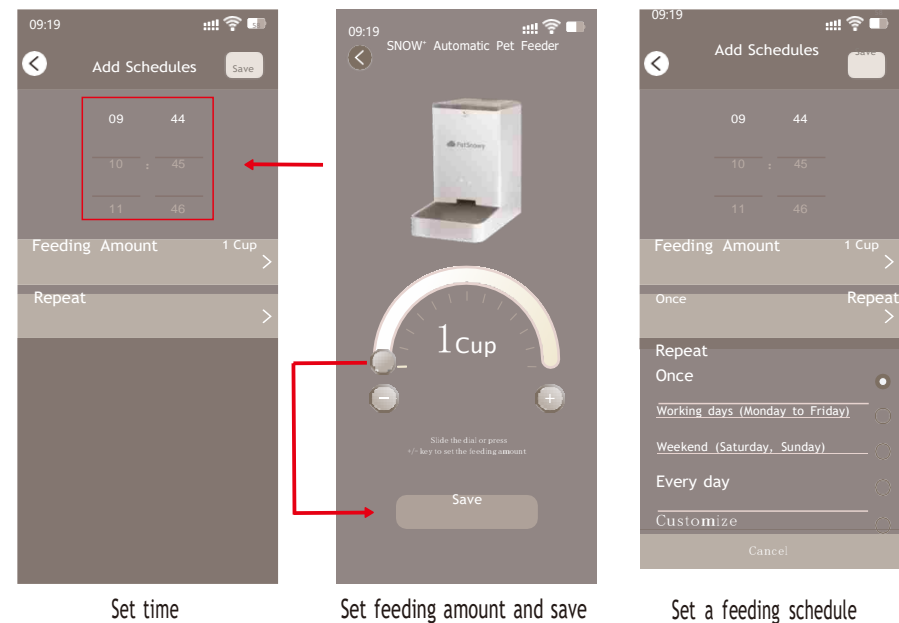
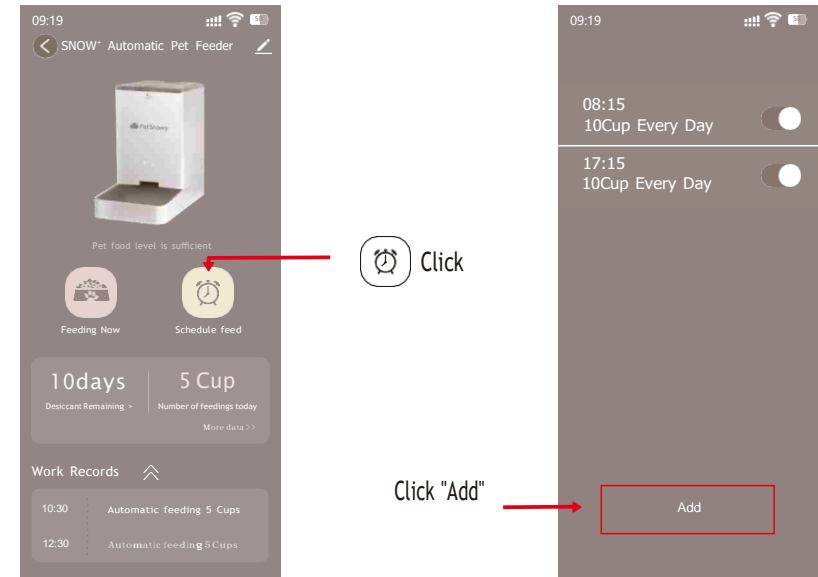

## •Feeding Records

Past feeding records can be searched on the app interface.

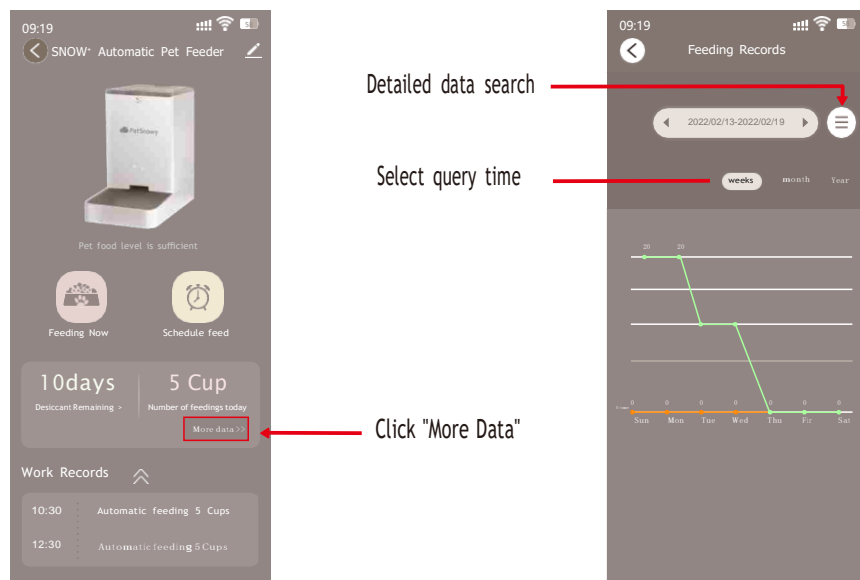

## FCC STATEMENT :

This device complies with Part 15 of the FCC Rules. Operation is subject to the following two conditions:

- (1) This device may not cause harmful interference, and
- (2) This device must accept any interference received, including interference that may cause undesired operation.

**Warning:** Changes or modifications not expressly approved by the party responsible for compliance could void the user's authority to operate the equipment.

**NOTE:** This equipment has been tested and found to comply with the limits for a Class B digital device, pursuant to Part 15 of the FCC Rules. These limits are designed to provide reasonable protection against harmful interference in a residential installation. This equipment generates uses and can radiate radio frequency energy and, if not installed and used in accordance with the instructions, may cause harmful interference to radio communications. However, there is no guarantee that interference will not occur in a particular installation. If this equipment does cause harmful interference to radio or television reception, which can be determined by turning the equipment off and on, the user is encouraged to try to correct the interference by one or more of the following measures: Reorient or relocate the receiving antenna. Increase the separation between the equipment and receiver. Connect the equipment into an outlet on a circuit different from that to which the receiver is connected. Consult the dealer or an experienced radio/TV technician for help.

**FCC Radiation Exposure Statement:**  
 This equipment complies with FCC radiation exposure limits set forth for an uncontrolled environment. This equipment should be installed and operated with minimum distance 20cm between the radiator & your body.

## TECHNICAL SPECIFICATIONS

Model	PS-020	Battery	4 x AA size
Name	SNOW <sup>+</sup> Automatic Pet Feeder	Food capacity	Max. 4L (Around 3.5 lbs)
Service environment	Indoor use only	Feeding tray volume	Max. 0.7L (Around 0.55 lbs)
Adapter	Input: 100-240VAC 50/60HZ Output: DC 5.9V/1.5A	Size	12.48x7.87x13.19 in (317x200x335mm)

## Warranty Card

Product \_\_\_\_\_

Place of purchase \_\_\_\_\_

Lowercase Shop address \_\_\_\_\_

Date of purchase \_\_\_\_\_ / \_\_\_\_\_ / \_\_\_\_\_

Shop signature \_\_\_\_\_

Purchaser signature \_\_\_\_\_

The product is warranted to be free of manufacturing and material defects for one (1) year from the date of purchase. Please save your dated original receipt or invoice as evidence of purchase and return the defective item to the point of purchase. Please keep in mind that this warranty does not cover damage caused by accident, misuse, or abuse. It also expressly disclaims any incidental or consequential damages, such as the loss of pets or other livestock as a result of any failure or fault in this product.