

PENDER

EBIKE LIFTER

Instruction Manual

Please read these instructions carefully and observe the cautions and instructions before using the ebike lifter for the first time.

To ensure perfect functionality, carry out the installation/assembly as shown.

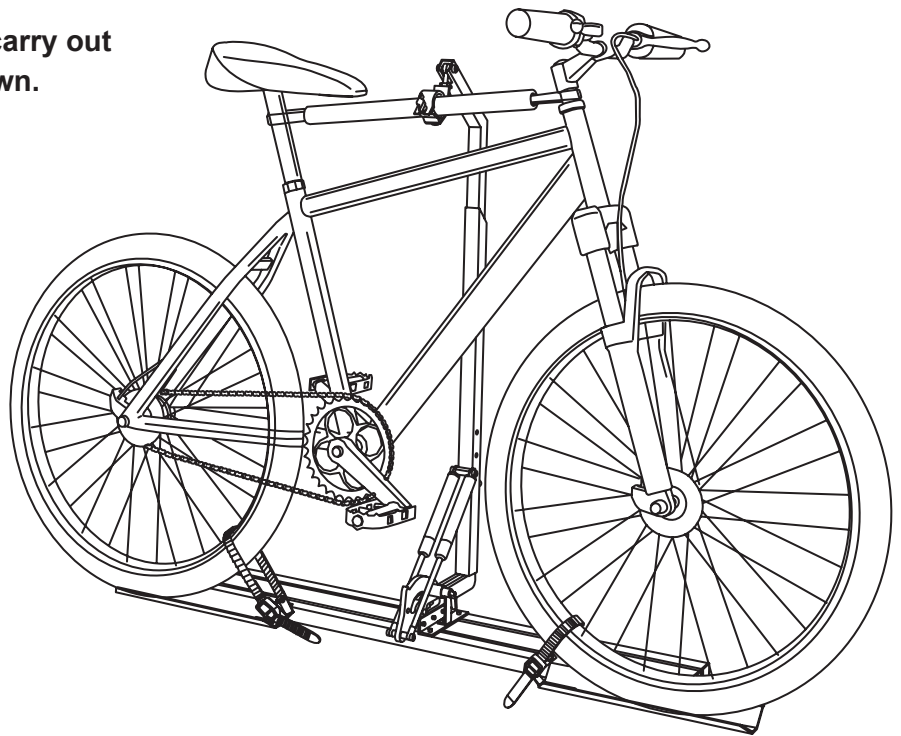

Contents

Page

1.	Safety information	2
2.	Overview of package contents	3
3.	Assembly of tension support tube	4
4.	Assembly of ebike lifter onto roof rack	5
5.	Placing the ebike in the mounting cradle	6
6.	Lifting the ebike	7
7.	Lowering the ebike onto the wheel rails and tightening the strap	9
8.	Releasing and lowering the ebike	11
9.	Unlocking and removing the telescopic arm	13
10.	Care instructions	14

1. Safety information

The driver of the vehicle is obliged to ensure that the roof rack is secured in accordance with the manufacturer's operating instructions and that road safety is not impaired.

The permissible roof load of the vehicle/roof rack must not be exceeded.

(This information can be found in the operating instructions for your vehicle or in the documentation for the roof rack).

The weight of an ebike lifter without an ebike is approximately 11 kg (24.25 lbs).

The maximum permissible load of the ebike lifter is 30 kg (66.14 lbs).

A maximum of 2 ebike lifters can be mounted on your vehicle, one lifter on each side.

When assembling the ebike lifter, ensure that no parts protrude beyond the vehicle's bodywork. Bicycle accessories such as saddlebags, pump, removable batteries, which may come loose during the journey, must be removed and stored in the vehicle. Do not attach tarpaulins or similar for the journey. Please note that the vehicle's driving behavior, such as when braking and with crosswind, changes due to the roof load.

For safety reasons, a speed of 130 km/h (80 mph) must not be exceeded during roof transportation. This will also reduce the wind resistance and will help to protect the environment.

Do not use the ebike lifter on roads that have been treated with de-icing salt (salt water spray). Do not expose the ebike lifter to the weather conditions permanently, and clean the lifter regularly.



The screw connections of all components, especially the retaining brackets, must be checked regularly.

- before every journey
- after approximately 15 km (9 miles) of driving
- on good roads approximately every 250 km (155 miles)
- on bad roads (vibrations) correspondingly more often



Remove the ebike lifter before using the car wash and parking garages!



When driving in and through, take into account the modified vehicle height!



2. Overview of package contents



Roof racks on which the ebike lifter is mounted are vehicle-specific and not included in the delivered contents!

1x Preassembled ebike lifter

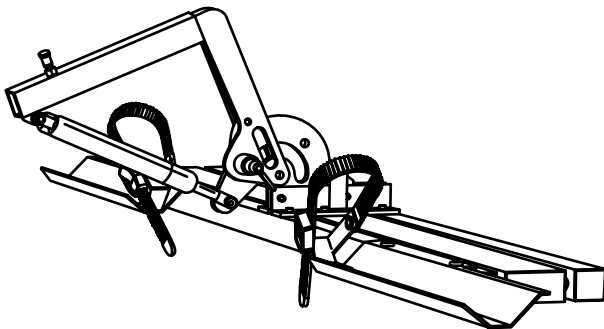

1x Tension support tube

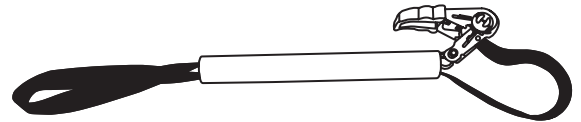

8x Tommy nuts

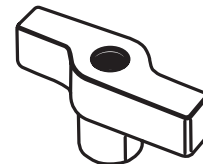

1x Telescopic arm

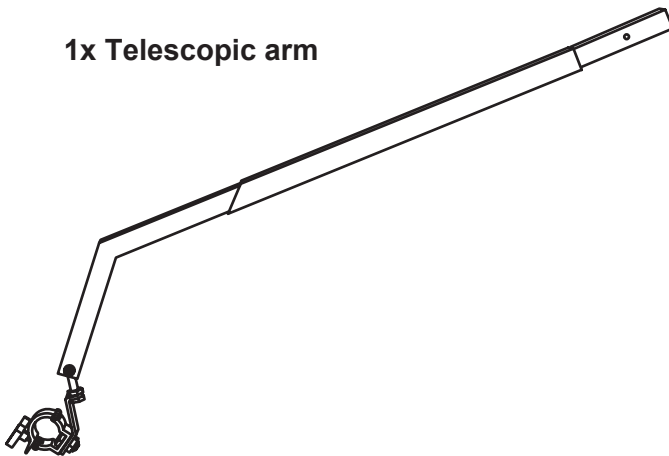

4x U - Bolts

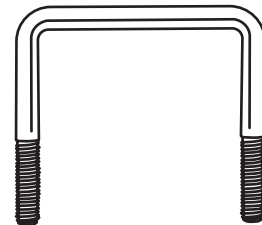

4x Spacer bars

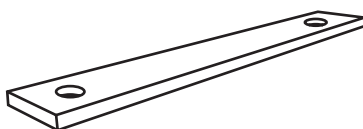

1x Velcro® strap

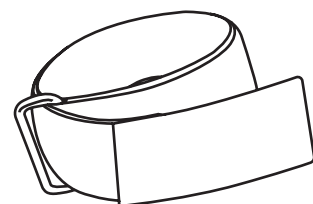

3. Assembly of tension support tube

The tension support tube (1) is to be attached between the saddle tube and handlebar steering head (above the bearing) (Figure 2). This is required to lift your ebike and secure it onto the ebike lifter during the journey.

Only pull the strap (2) out of the support tube until it can be placed around the saddle tube. Then place the loose end of the strap around the handlebar steering head and push it into the open ratchet (3) (Figure 3).

Tighten the strap so that the tension support tube is as horizontal as possible between the saddle and the handlebar steering head so that the handlebar can no longer move back and forth (Figure 4).

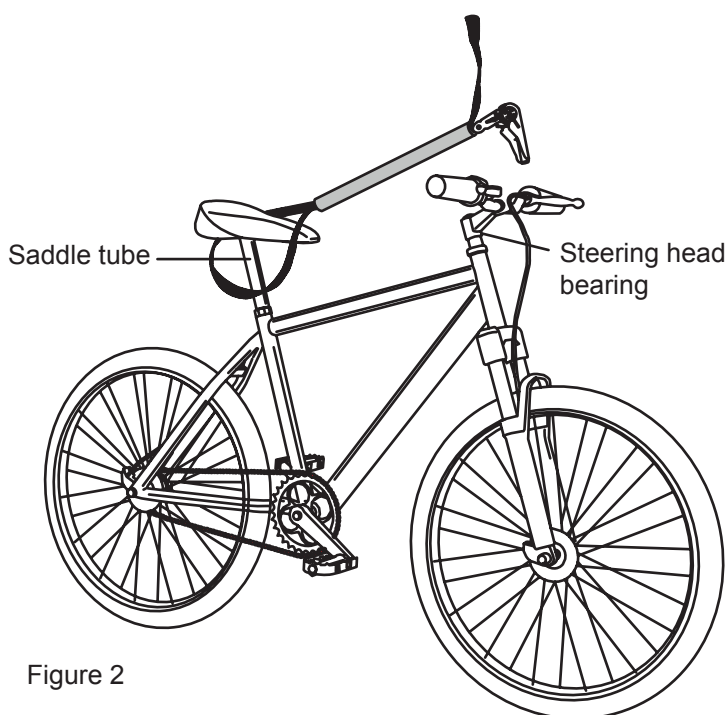
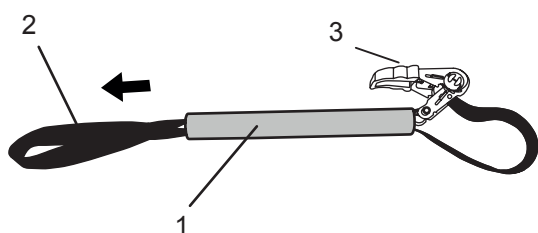

Figure 2

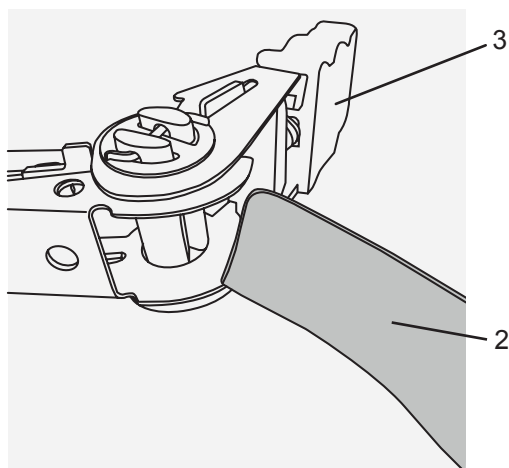

Figure 3

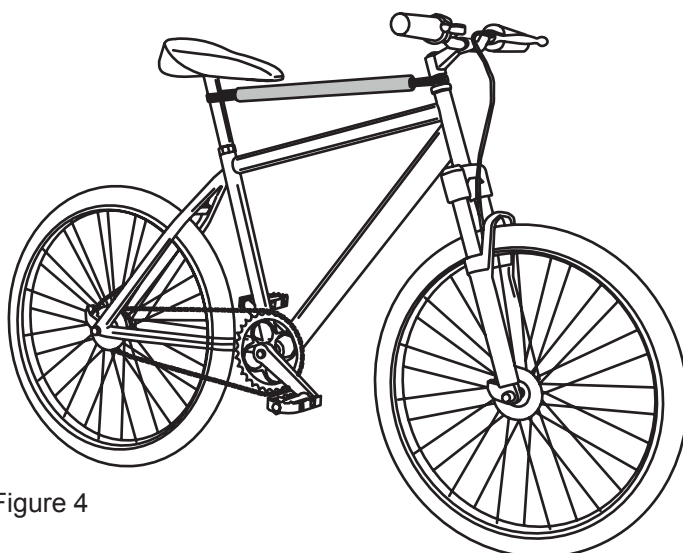

Figure 4

4. Assembly of ebike lifter onto the roof rack

Place the ebike lifter in the center of the roof rack as far to the outside of the vehicle as possible.



The ebike lifter must not protrude beyond the width of the car!

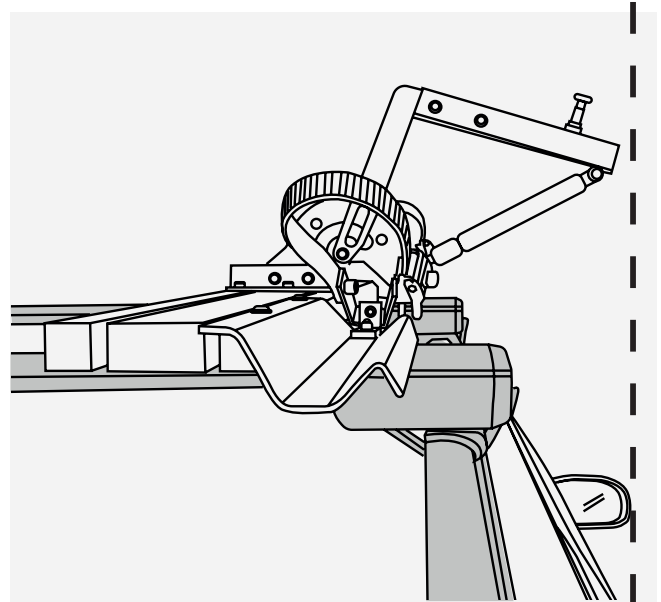
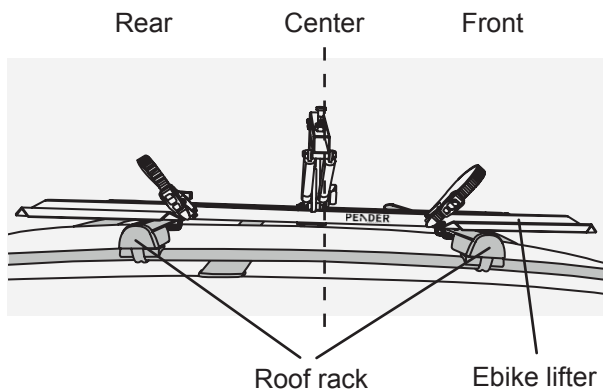

Slide the 4 U-bolts (4) from below over the roof rack through the profiles of the ebike lifter, place the spacer bars (5) over them, and screw them on hand-tight with the tommy nuts (6).

Tighten the tommy nuts alternately and evenly by hand.

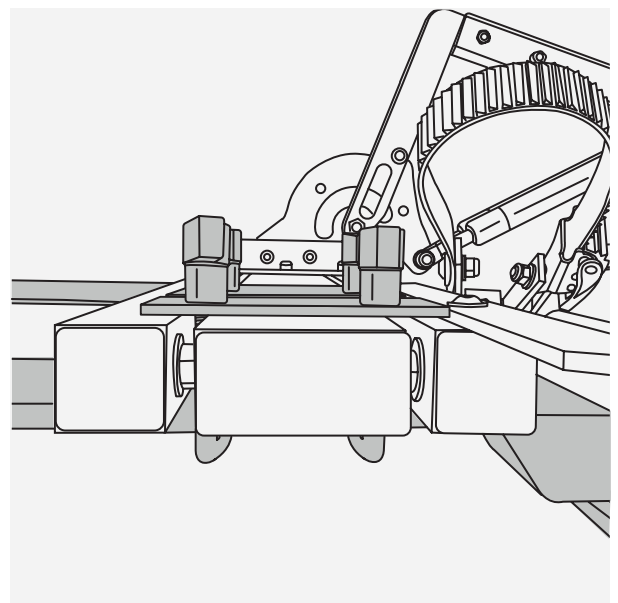
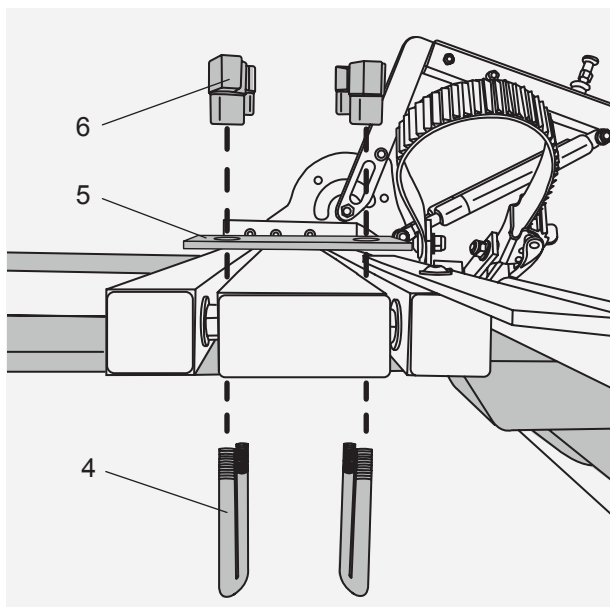

The telescopic support arm must now be pushed into the mounting opening (7) of the ebike lifter until the locking bolt (8) clicks into position. Pull on the telescopic support arm to ensure that it is firmly fixed.

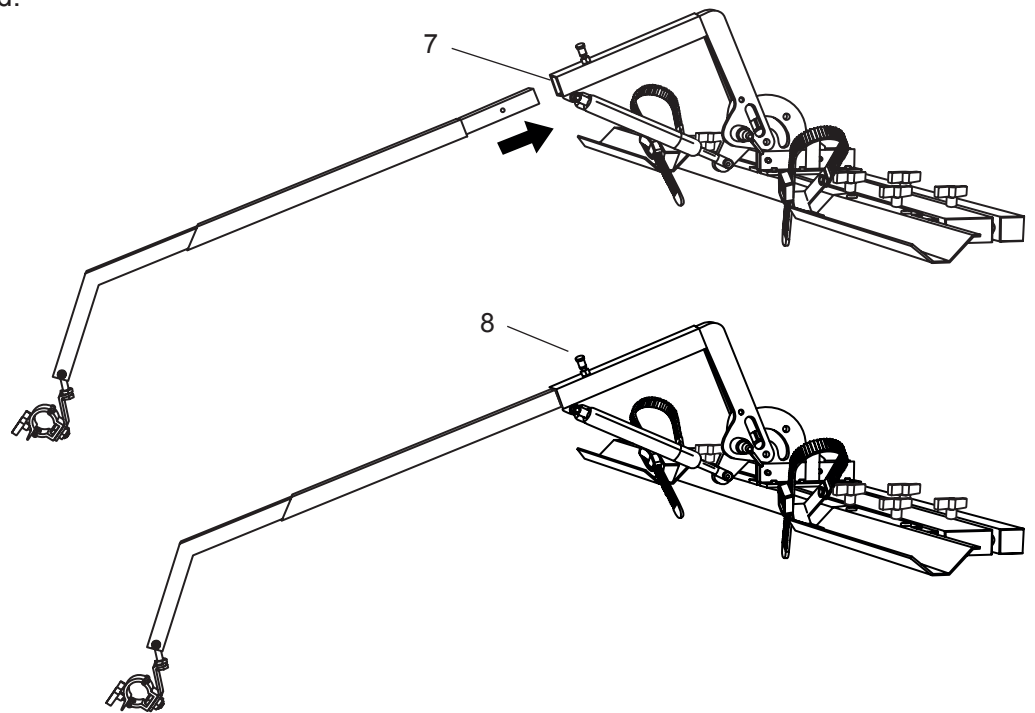

5. Placing the ebike in the mounting cradle

Pull the mounting cradle (9) forward so that its clasp remains positioned to the rear and the mounting cradle remains open.

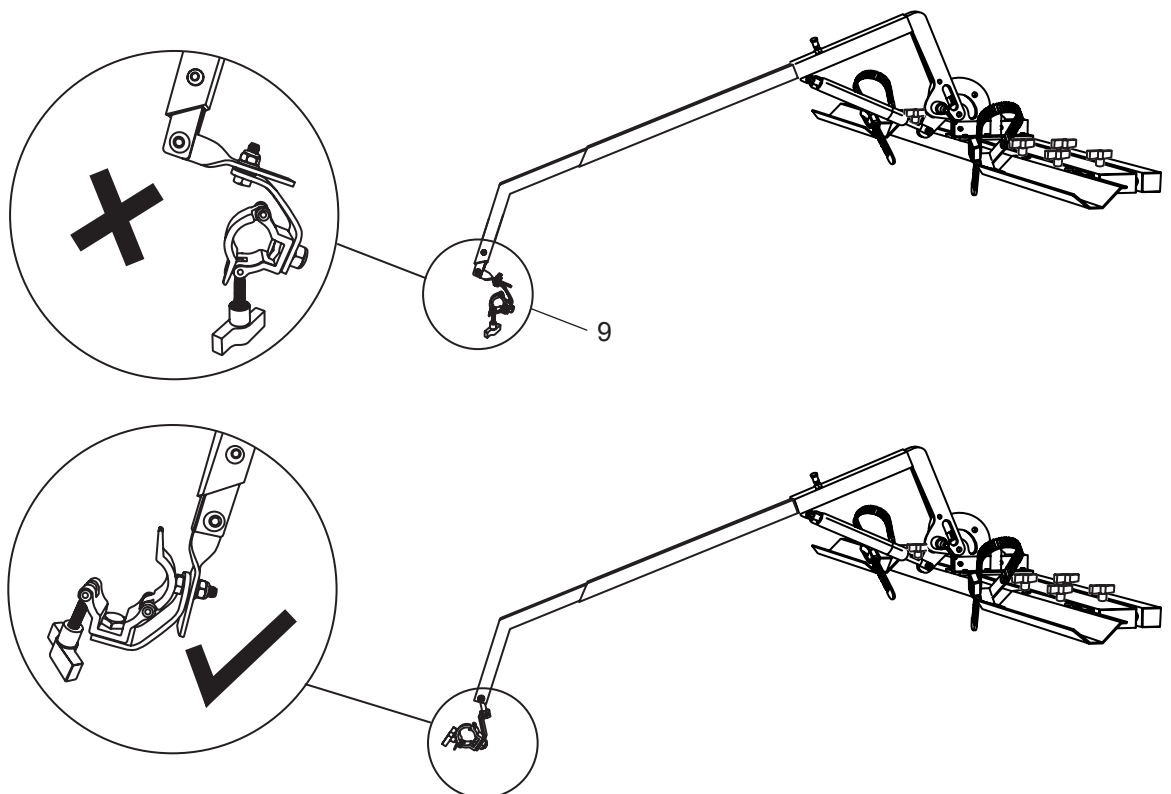

Place the ebike with the tension support tube (1) in the mounting cradle (9) so that the bicycle wheels are, as far as possible, the same distance from the ground.

Close the mounting cradle and **tighten the tommy nut (10)**.

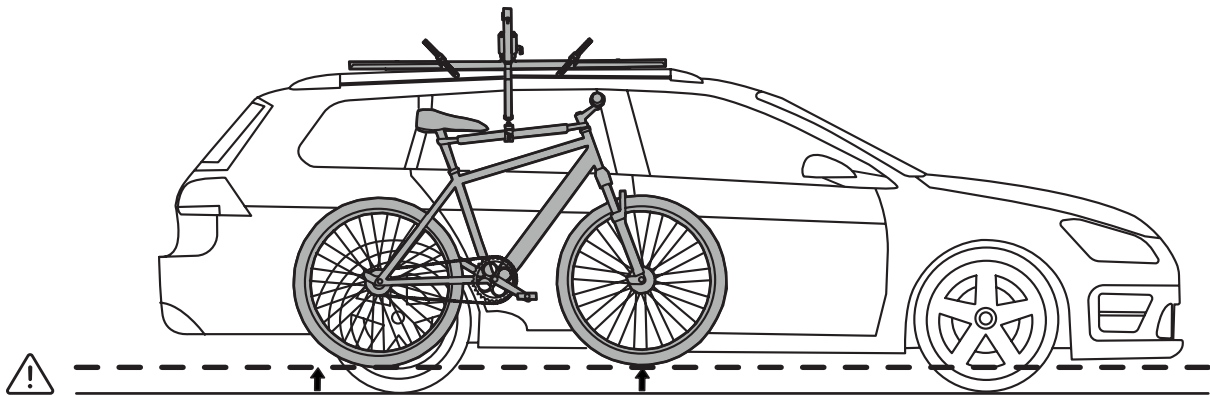
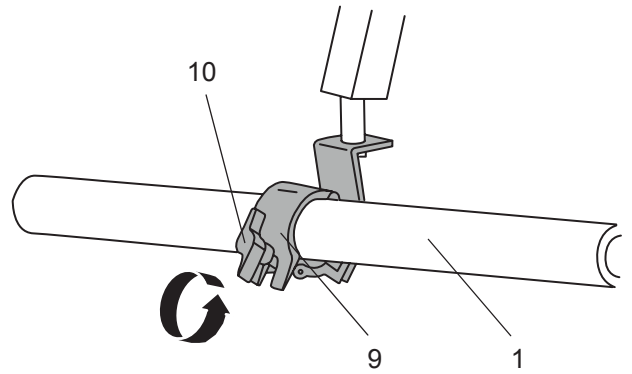

6. Lifting the ebike



Make sure that the ebike is not touching the ground, otherwise the lever of the locking bolt (11) cannot be released! Never use force or a tool to release it. RISK OF INJURY!

When the ebike is secured in the mounting cradle and is hovering above the ground (**not before!**), release the lever of the locking bolt (11) and move it to the free position (small notch a) of the locking bolt.

Start position

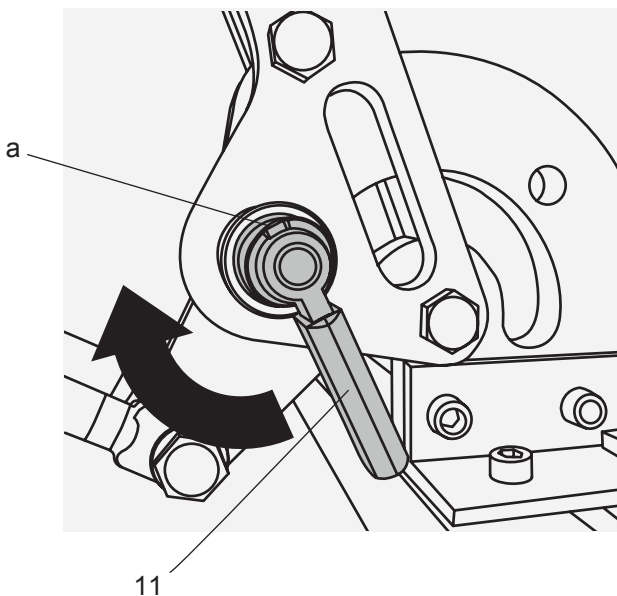

Free position

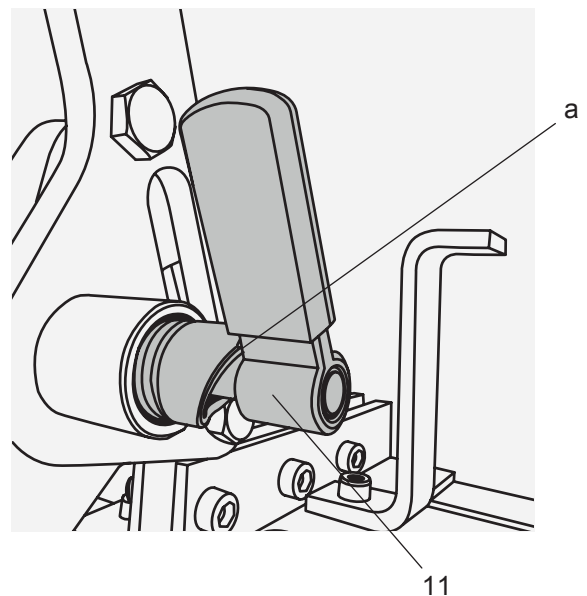

Hold the ebike by the frame with both hands above the bottom bracket and lift it up. The higher the ebike is lifted, the lighter it becomes.

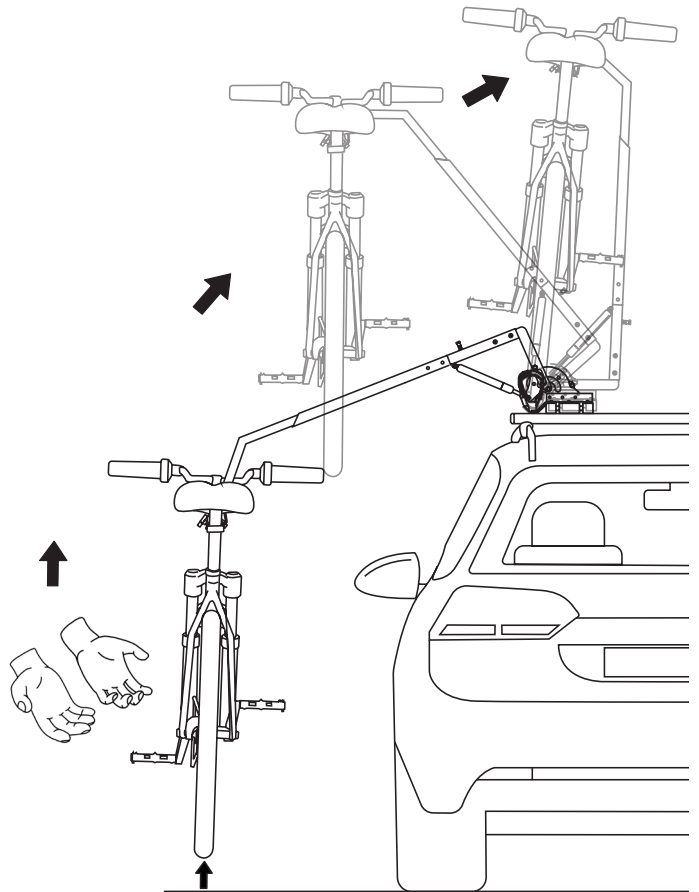

Make sure that the ebike is not touching the ground!

The ebike must now be guided over the ebike lifter until the lever of the locking bolt (11) locks into the telescopic arm (now in a vertical position), as a transport securing device for safety.

The locking bolt is pressed into the locking position by the deflection lever (12). Only then is the lifter correctly fixed and secured.

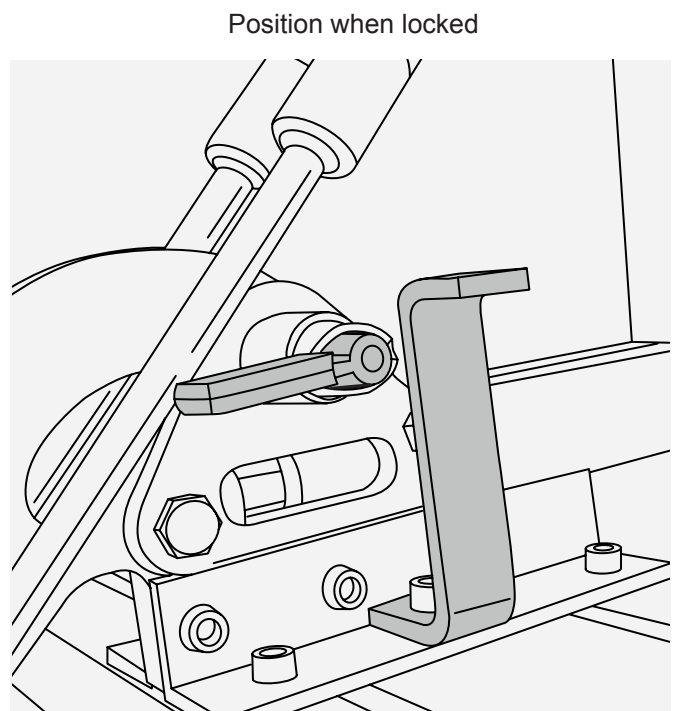
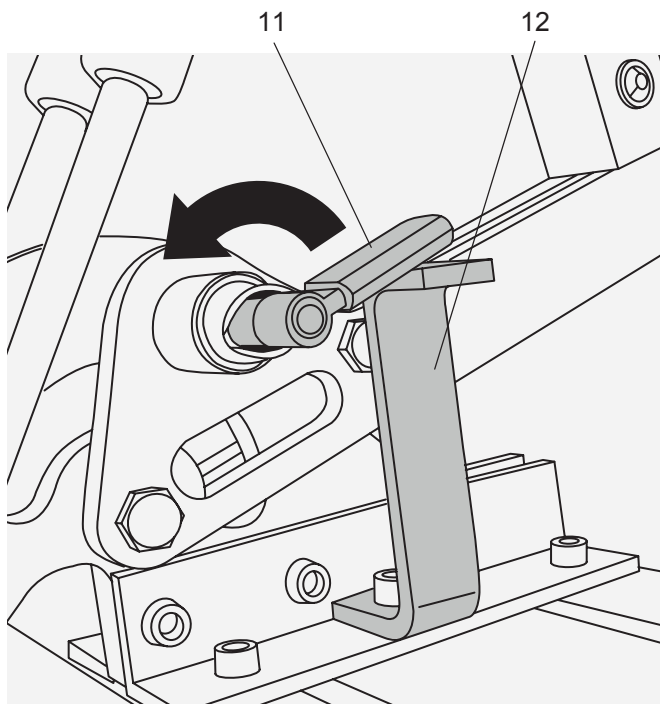

7. Lowering the ebike onto the wheel rails and tightening the strap

The ebike can now be pulled down by the wheels onto the premounted rails.

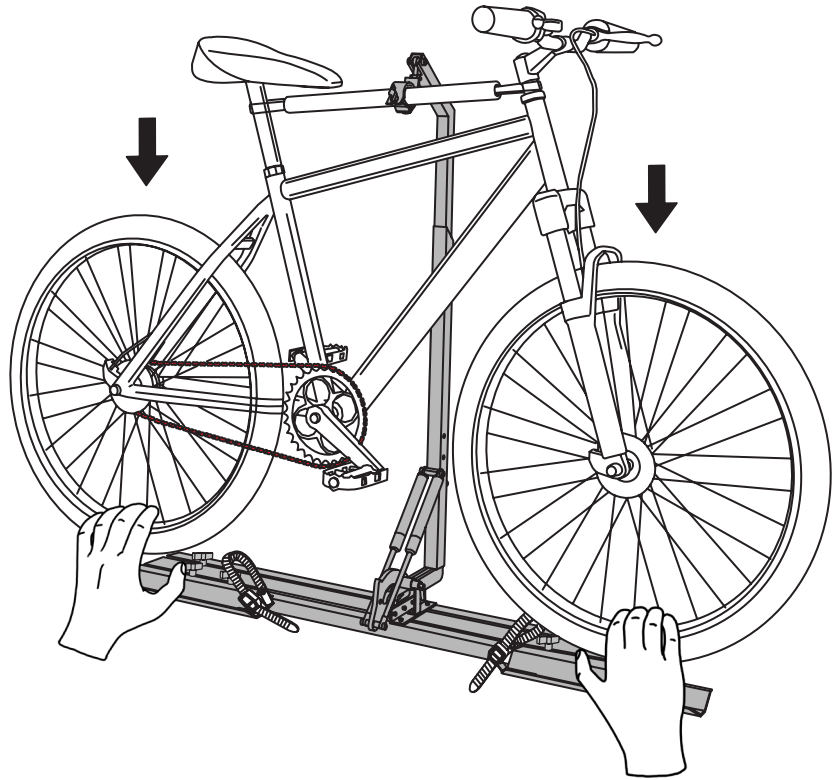

Freewheel pedals are to be fixed to the frame of the ebike using the provided Velcro® strap (13) to prevent the pedals from turning in the wind.

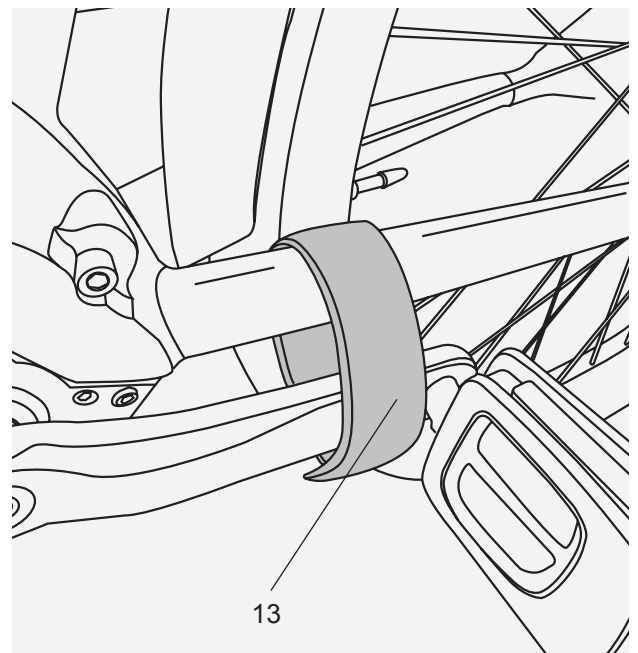

The tensioning straps (14) must now be pulled through the ratchets (15) and tensioned alternately on the front and rear wheels by moving the lever (16) up and down until the wheels rest firmly on the rails (17). The support arm (12) must remain in a vertical position.

Make sure that the ratchet strap does not touch a wheel spoke when tightening.

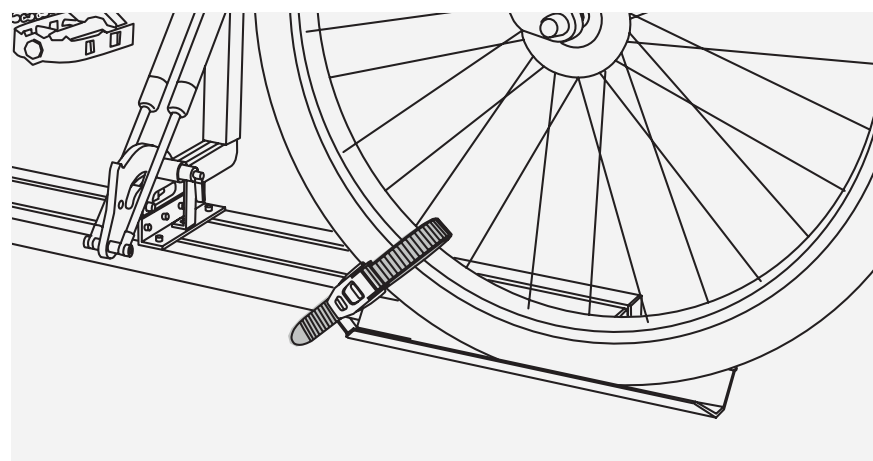
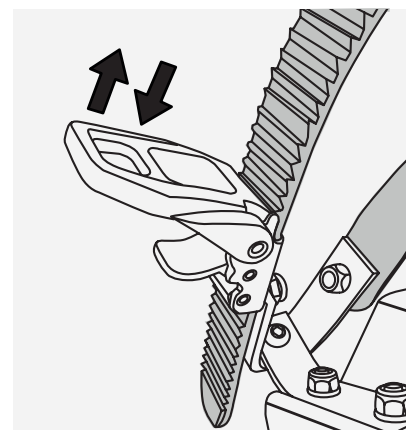
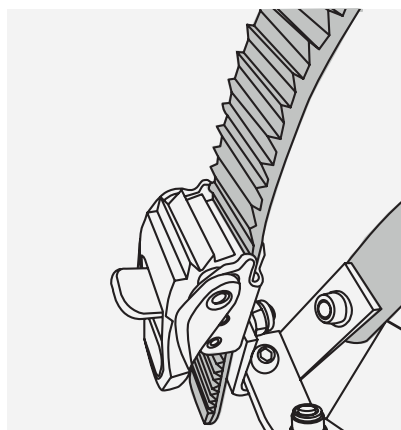
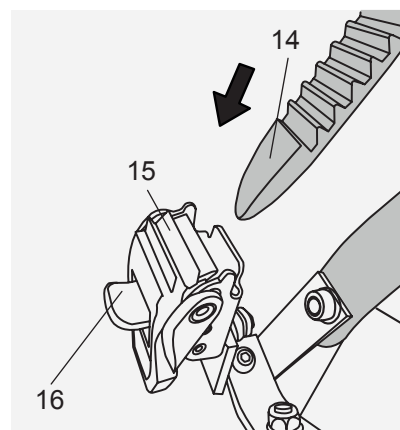
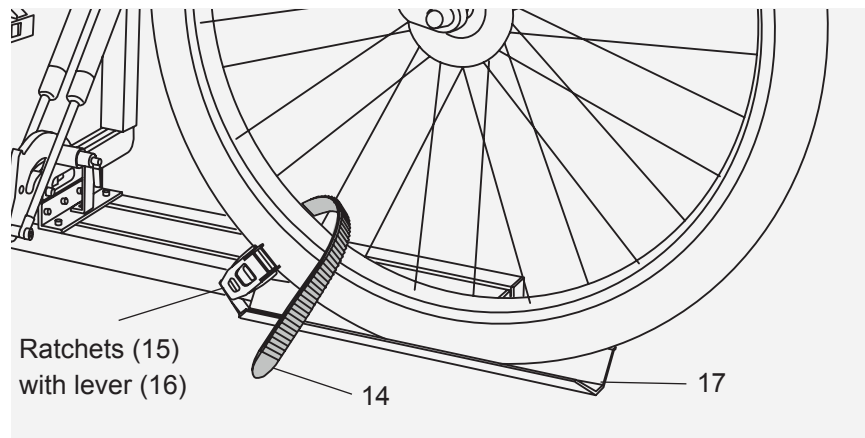

i Check again before the journey and after a few kilometers (miles) to ensure that the ebike is still securely fastened.

8. Releasing and lowering the ebike

First press the small locking levers (16) of the ratchets firmly downward and pull the straps out of the ratchets.

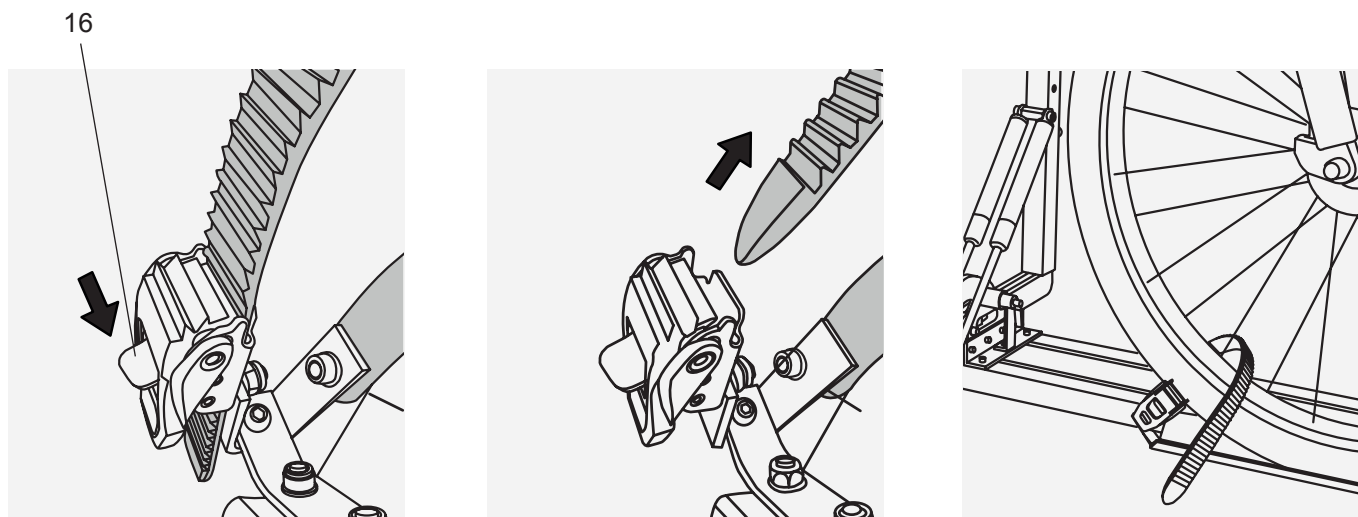

Then release the lever (11) of the locking bolt and turn it into the locking position under the deflection lever (12) ...



Never attempt to reposition the locking bolt when the tommy nut of the mounting cradle is loose!

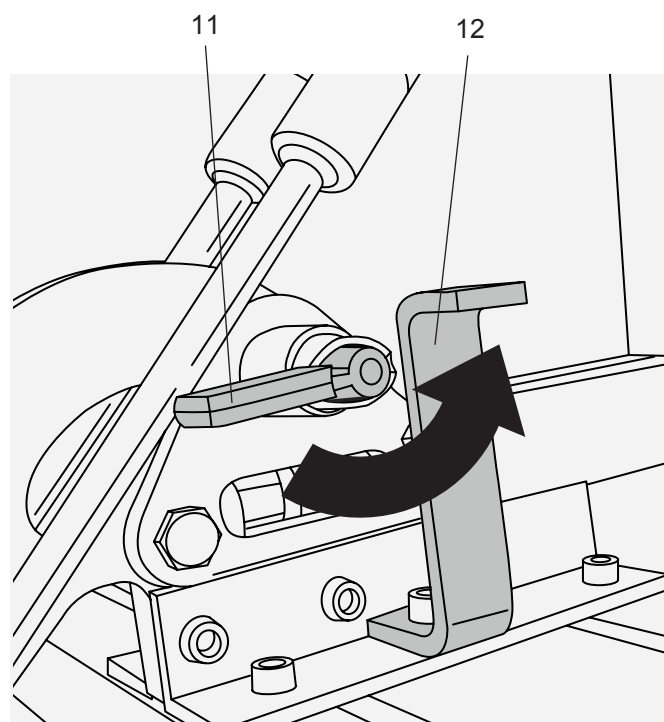

Locking position

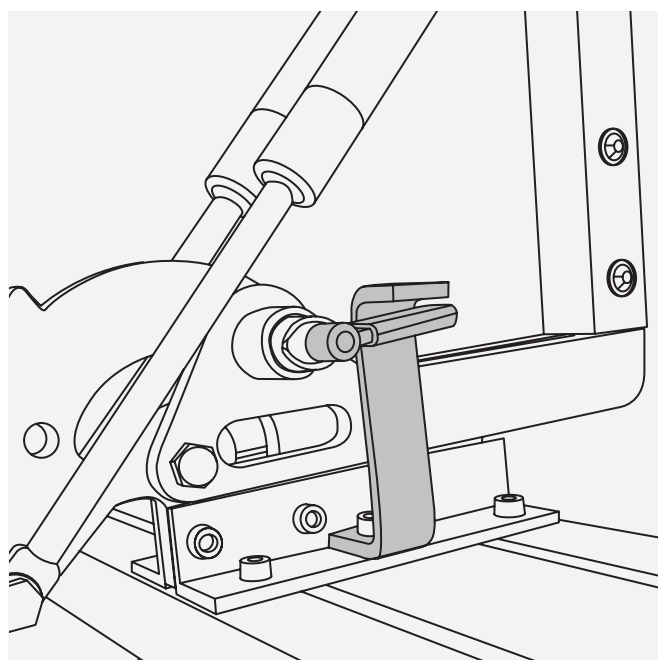

... Now grasp the ebike at the bottom of the wheels and pull the initially floating ebike away from the vehicle and then downward.

As soon as it is possible, reach upward, for example, to the tension support tube.

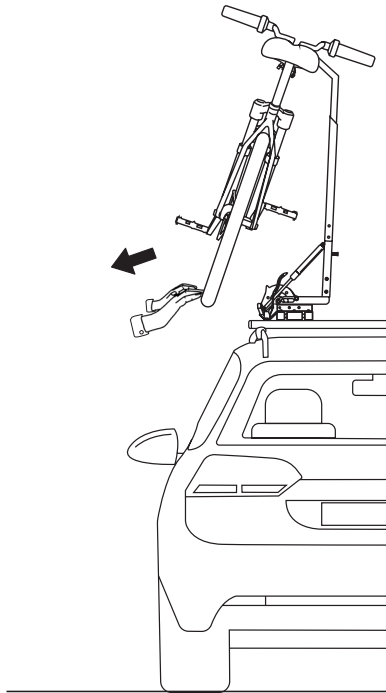

The telescopic arm extends automatically to restore the distance to the vehicle. **In the lower position, the lever of the locking bolt (11) locks in place again**, allowing the ebike to be removed from the mounting cradle.

Engaged position
(corresponds to start position)

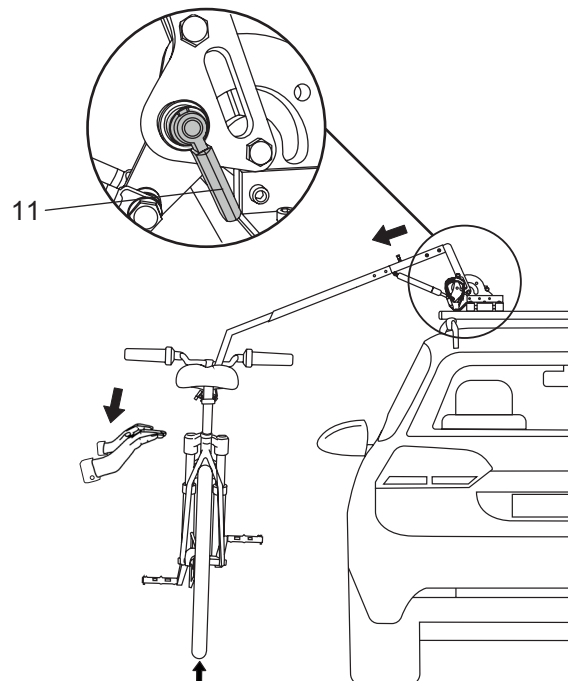

Do not remove the ebike from the holder until the lever of the locking bolt (11) has locked in place. RISK OF INJURY!



The ebike must not be in contact with the ground before it is removed. Only then can you be sure that the locking bolt (8) is locked in place!

After loosening the tommy nut (10) of the mounting cradle (9), the ebike can be removed.

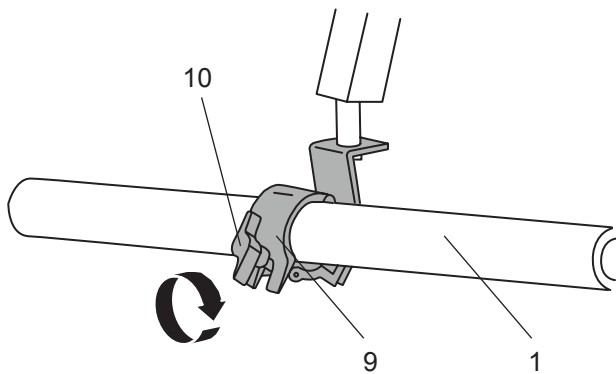

Remove the tension support tube (1) from the ebike after loosening the ratchet strap (2) by opening the ratchet (3) completely.

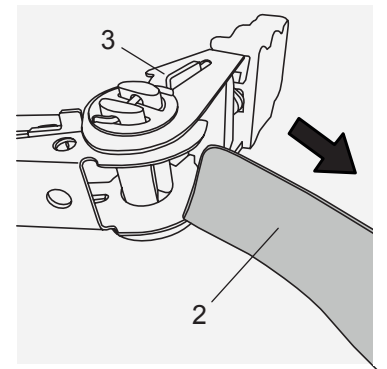

9. Unlocking and removing the telescopic arm

If the ebike lifter is to remain on the vehicle during an journey, for example, the telescopic arm must be pulled out. The same applies before removing the ebike lifter from the roof rack!

To do this, pull the locking bolt (8) upward and, at the same time, and pull the telescopic arm out approximately 20 mm (7.5 inches), but not completely. Then release the locking bolt and remove the telescopic arm with both hands.

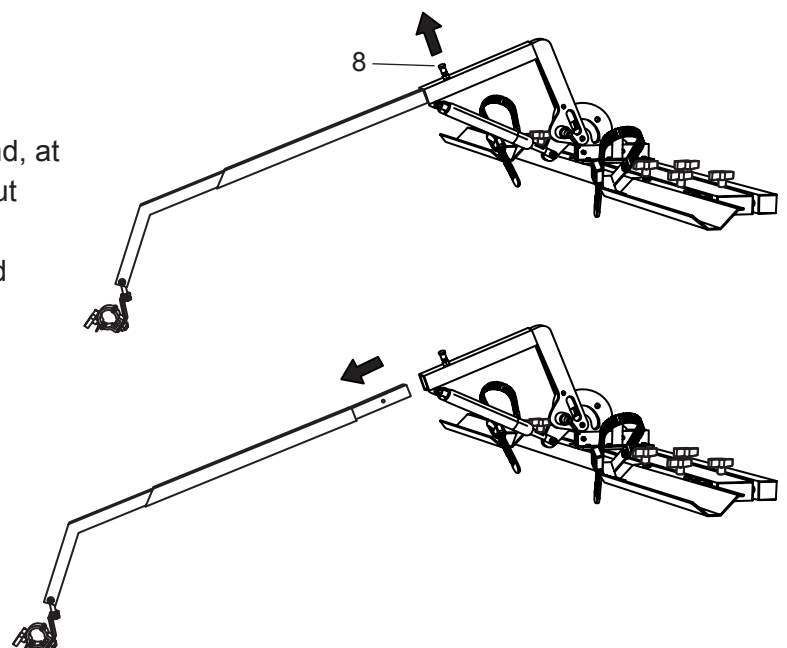

10. Care instructions

There is no MOT (vehicle safety inspection) for bicycle carriers, the responsibility lies solely with the owner.

For this reason, the care and maintenance instructions should be observed.

After using and dismantling the ebike lifter, it should be cleaned and stored properly.

The ebike lifter should be cleaned and maintained regularly.

Especially in winter, dirt and salt should be removed.

The ebike lifter can be cleaned with water and standard car shampoo.

ATTENTION!

Never use lubricants on the screw(bolt connections).

This can cause the these connections to loosen on their own and the ebike lifter or the ebike could come loose. This can injure you or other persons and lead to property damage.

CAUTION!

Do not use aggressive cleaning agents or a high-pressure cleaner to clean the ebike lifter.