

GeoMax Zoom10



User Manual

Version 1.0
English



Introduction

Purchase

Congratulations on the purchase of the GeoMax Zoom10.



This manual contains important safety directions as well as instructions for setting up the product and operating it. Refer to "1 Safety Directions" for further information.

Read carefully through the User Manual before you switch on the product.

To ensure safety when using the system, please also observe the directions and instructions contained in the User Manual and Safety Handbook issued by the Machine manufacturer.



The content of this document is subject to change without prior notice. Ensure that the product is used in accordance with the latest version of this document.

Updated versions are available for download at the following Internet address:

<https://partners.geomax-positioning.com/downloads.htm>

Product identification

The model and serial number of your product are indicated on the type plate.

Always refer to this information when you contact your agency or GeoMax authorised service workshop.

Trademarks

- Windows is a registered trademark of Microsoft Corporation in the United States and other countries

All other trademarks are the property of their respective owners.

Validity of this manual

	Description
General	This manual applies to Zoom10 instruments. Where there are differences between the models they are clearly described.
Telescope	<ul style="list-style-type: none">• Measuring with P modes: When measuring distances to a reflector with Electronic Distance Measurement (EDM) mode "P", the telescope uses a wide visible red laser beam, which emerges coaxially from the telescope's objective.• Measuring with NP modes: Instruments that are equipped with a reflectorless EDM additionally offer the EDM mode "NP". When measuring distances with this EDM mode, the telescope uses a narrow visible red laser beam, which emerges coaxially from the telescope's objective.

NOTICE

Removal of battery during operation or shutdown

This can result in a file system error and data loss!

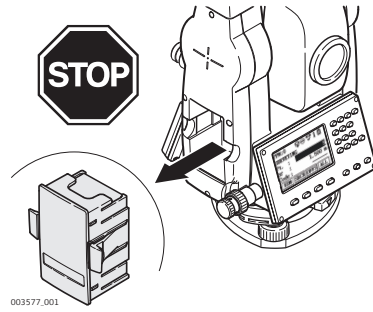

Precautions:

- ▶ Do **NOT** remove the battery during operation of the instrument, or during the shutdown procedure.
 - ▶ Always switch off the instrument by pressing the ON/OFF key, and wait until the instrument has shutdown completely before removing the battery.
-

Table of Contents

1	Safety Directions	7
1.1	General	7
1.2	Definition of Use	7
1.3	Limits of Use	8
1.4	Responsibilities	8
1.5	Hazards of Use	8
1.6	Laser Classification	10
1.6.1	General	10
1.6.2	Distancer, Measurements with Reflectors	11
1.6.3	Distancer, Measurements without Reflectors (NP mode)	11
1.6.4	Laser Plummet	13
1.7	Electromagnetic Compatibility (EMC)	14
1.8	FCC Statement, Applicable in U.S.	15
1.9	ISED Statement, Applicable in Canada	16
2	Description of the System	17
2.1	System Components	17
2.2	Delivery Contents	17
2.3	Instrument Components	18
3	User Interface	19
3.1	Keyboard	19
3.2	Screen	20
3.3	Status Icons	20
3.4	Softkeys	21
3.5	Operating Principles	22
3.6	Pointsearch	23
4	Operation	24
4.1	Working with the Battery	24
4.2	Instrument Setup	24
4.3	Data Storage	26
4.4	Main Menu	26
4.5	Quick-Survey Application	27
4.6	Distance Measurements - Guidelines for Correct Results	29
5	Settings	31
5.1	General Settings	31
5.2	EDM Settings	33
6	Tools	36
6.1	Adjust	36
6.2	System Information	36
7	Functions	37
7.1	Overview	37
7.2	Offset	37
7.2.1	Distance Offset	37
7.2.2	Cylindrical Offset	38
7.2.3	Angle Offset	40
7.3	Height Transfer	41
7.4	Hidden Point	42
7.5	Coding	43
8	Applications - Getting Started	45
8.1	Overview	45
8.2	Starting an App	45
8.3	Selecting the Job	45
8.4	Selecting the Station	47

8.5	Selecting the Orientation	48
8.5.1	Overview	48
8.5.2	Manual Orientation	48
8.5.3	Orientation with Coordinates	49
9	Application	51
9.1	Input and Result Fields	51
9.2	Surveying	54
9.3	Stakeout	54
9.4	Resection	56
9.5	Tie Distance	58
9.6	Area	60
9.7	Remote Height	61
9.8	COGO	62
9.8.1	Starting	62
9.8.2	COGO Calculation - Inverse Method	62
9.8.3	COGO Calculation - Traverse Method	63
9.8.4	COGO Calculation - Intersections	64
9.8.5	COGO Calculation - Offsets	67
9.8.6	COGO Calculation - Extension Method	68
9.9	Road	69
9.9.1	Overview	69
9.9.2	Road Manage	69
9.9.3	Horizontal Curve Definition	70
9.9.4	Vertical Curve Definition	72
9.9.5	Road Stakeout	74
9.10	Stakeout Reference Element	76
9.10.1	Overview	76
9.10.2	Reference Line	76
9.10.3	Reference Arc	81
10	Data Management	84
10.1	Overview	84
10.2	Managing Jobs	85
10.3	Managing Fix Points	85
10.4	Managing Measurement Data	85
10.5	Managing Codes	86
10.6	Managing Memory Space	86
11	Data Transfer	87
11.1	Overview	87
11.2	Importing Data	87
11.3	Exporting Data	88
11.4	Working with X-Pad	89
12	Check & Adjust	90
12.1	Overview	90
12.2	Preparation	90
12.3	Adjustments	90
12.4	Adjust Index Error	91
12.5	Adjust Tilt X / Tilt Y	92
13	Care and Transport	93
13.1	Transport	93
13.2	Storage	93
13.3	Cleaning and Drying	93
14	Technical Data	95
14.1	General Technical Data of the Product	95
14.2	Angle Measurement	96
14.3	Distance Measurement with Reflectors	96
14.4	Distance Measurements without Reflectors (Reflectorless mode)	96

14.5	Conformity to National Regulations	97
14.6	Scale Correction	97
14.7	Reduction Formulas	99
15	Software Licence Agreement	101
Appendix A	Menu Tree	102
Appendix B	Glossary	103

1 Safety Directions

1.1 General

Description

The following directions enable the person responsible for the product, and the person who actually uses the equipment, to anticipate and avoid operational hazards.

The person responsible for the product must ensure that all users understand these directions and adhere to them.

About warning messages





Warning messages are an essential part of the safety concept of the instrument. They appear wherever hazards or hazardous situations can occur.

Warning messages...

- make the user alert about direct and indirect hazards concerning the use of the product.
- contain general rules of behaviour.

For the users' safety, all safety instructions and safety messages shall be strictly observed and followed! Therefore, the manual must always be available to all persons performing any tasks described here.

DANGER, WARNING, CAUTION and **NOTICE** are standardised signal words for identifying levels of hazards and risks related to personal injury and property damage. For your safety, it is important to read and fully understand the following table with the different signal words and their definitions! Supplementary safety information symbols may be placed within a warning message as well as supplementary text.

Type	Description
 DANGER	Indicates an imminently hazardous situation which, if not avoided, will result in death or serious injury.
 WARNING	Indicates a potentially hazardous situation or an unintended use which, if not avoided, could result in death or serious injury.
 CAUTION	Indicates a potentially hazardous situation or an unintended use which, if not avoided, may result in minor or moderate injury.
NOTICE	Indicates a potentially hazardous situation or an unintended use which, if not avoided, may result in appreciable material, financial and environmental damage.
	Important paragraphs which must be adhered to in practice as they enable the product to be used in a technically correct and efficient manner.

1.2 Definition of Use

Intended use

- Measuring horizontal and vertical angles.
- Measuring distances.
- Recording measurements.
- Visualising the aiming direction and vertical axis.
- Data communication with external appliances.
- Computing with software.

Reasonably foreseeable misuse

- Use of the product without instruction.
- Use outside of the intended use and limits.
- Disabling safety systems.
- Removal of hazard notices.
- Opening the product using tools, for example screwdriver, unless this is specifically permitted for certain functions.
- Modification or conversion of the product.
- Use after misappropriation.
- Use of products with obviously recognisable damages or defects.
- Use with accessories from other manufacturers without the prior explicit approval of GeoMax.
- Aiming directly into the sun.
- Inadequate safeguards at the working site.
- Deliberate dazzling of third parties.
- Controlling of machines, moving objects or similar monitoring application without additional control- and safety installations.

1.3

Limits of Use

Environment

Suitable for use in an atmosphere appropriate for permanent human habitation: not suitable for use in aggressive or explosive environments.

WARNING

Working in hazardous areas, or close to electrical installations or similar situations

Life Risk.

Precautions:

- ▶ Local safety authorities and safety experts must be contacted by the person responsible for the product before working in such conditions.

1.4

Responsibilities

Manufacturer of the product

GeoMax AG, CH-9443 Widnau, hereinafter referred to as GeoMax, is responsible for supplying the product, including the user manual and original accessories, in a safe condition.

Person responsible for the product

The person responsible for the product has the following duties:

- To understand the safety instructions on the product and the instructions in the user manual.
- To ensure that it is used in accordance with the instructions.
- To be familiar with local regulations relating to safety and accident prevention.
- To inform GeoMax immediately if the product and the application becomes unsafe.
- To ensure that the national laws, regulations and conditions for the operation of e.g. radio transmitters or lasers are respected.

1.5

Hazards of Use

NOTICE

Dropping, misusing, modifying, storing the product for long periods or transporting the product

Watch out for erroneous measurement results.

Precautions:

- ▶ Periodically carry out test measurements and perform the field adjustments indicated in the User Manual, particularly after the product has been subjected to abnormal use as well as before and after important measurements.

⚠ DANGER

Risk of electrocution

Because of the risk of electrocution, it is dangerous to use poles, levelling staffs and extensions in the vicinity of electrical installations such as power cables or electrical railways.

Precautions:

- ▶ Keep at a safe distance from electrical installations. If it is essential to work in this environment, first contact the safety authorities responsible for the electrical installations and follow their instructions.



⚠ CAUTION

Pointing product toward the sun

Be careful when pointing the product toward the sun, because the telescope functions as a magnifying glass and can injure your eyes and/or cause damage inside the product.

Precautions:

- ▶ Do not point the product directly at the sun.

⚠ WARNING

Distraction/loss of attention

During dynamic applications, for example stakeout procedures, there is a danger of accidents occurring if the user does not pay attention to the environmental conditions around, for example obstacles, excavations or traffic.

Precautions:

- ▶ The person responsible for the product must make all users fully aware of the existing dangers.

⚠ WARNING

Inadequate securing of the working site

This can lead to dangerous situations, for example in traffic, on building sites and at industrial installations.

Precautions:

- ▶ Always ensure that the working site is adequately secured.
- ▶ Adhere to the regulations governing safety, accident prevention and road traffic.

⚠ CAUTION

Not properly secured accessories

If the accessories used with the product are not properly secured and the product is subjected to mechanical shock, for example blows or falling, the product may be damaged or people can sustain injury.

Precautions:

- ▶ When setting up the product, make sure that the accessories are correctly adapted, fitted, secured, and locked in position.
- ▶ Avoid subjecting the product to mechanical stress.

⚠ WARNING

Lightning strike

If the product is used with accessories, for example masts, staffs, poles, you may increase the risk of being struck by lightning.

Precautions:

- ▶ Do not use the product in a thunderstorm.

⚠ WARNING

Inappropriate mechanical influences to batteries

During the transport, shipping or disposal of batteries it is possible for inappropriate mechanical influences to constitute a fire hazard.

Precautions:

- ▶ Before shipping the product or disposing it, discharge the batteries by the product until they are flat.
- ▶ When transporting or shipping batteries, the person in charge of the product must ensure that the applicable national and international rules and regulations are observed.
- ▶ Before transportation or shipping, contact your local passenger or freight transport company.

⚠ WARNING

Exposure of batteries to high mechanical stress, high ambient temperatures or immersion into fluids

This can cause leakage, fire or explosion of the batteries.

Precautions:

- ▶ Protect the batteries from mechanical influences and high ambient temperatures. Do not drop or immerse batteries into fluids.

⚠ WARNING

Short circuit of battery terminals

If battery terminals are short circuited e.g. by coming in contact with jewellery, keys, metallised paper or other metals, the battery can overheat and cause injury or fire, for example by storing or transporting in pockets.

Precautions:

- ▶ Make sure that the battery terminals do not come into contact with metallic objects.

⚠ WARNING

If the product is improperly disposed of, the following can happen:

- If polymer parts are burnt, poisonous gases are produced which may impair health.
- If batteries are damaged or are heated strongly, they can explode and cause poisoning, burning, corrosion or environmental contamination.
- By disposing of the product irresponsibly you may enable unauthorised persons to use it in contravention of the regulations, exposing themselves and third parties to the risk of severe injury and rendering the environment liable to contamination.

Precautions:

▶



The product must not be disposed with household waste. Dispose of the product appropriately in accordance with the national regulations in force in your country. Always prevent access to the product by unauthorised personnel.

Product-specific treatment and waste management information is available from GeoMax AG.

⚠ WARNING

Only GeoMax authorised service workshops are entitled to repair these products.

1.6

Laser Classification

1.6.1

General

General

The following chapters provide instructions and training information about laser safety according to international standard IEC 60825-1 (2014-05) and technical report IEC TR 60825-14 (2004-02). The information enables the person responsible for the product and the person who actually uses the equipment, to anticipate and avoid operational hazards.



According to IEC TR 60825-14 (2004-02), products classified as laser class 1, class 2 and class 3R do not require:

- laser safety officer involvement,
- protective clothes and eyewear,
- special warning signs in the laser working area

if used and operated as defined in this User Manual due to the low eye hazard level.



National laws and local regulations could impose more stringent instructions for the safe use of lasers than IEC 60825-1 (2014-05) and IEC TR 60825-14 (2004-02).

1.6.2

Distancer, Measurements with Reflectors

General

The EDM module built into the product produces a visible laser beam which emerges from the telescope objective.

The laser product described in this section is classified as laser class 1 in accordance with:

- IEC 60825-1 (2014-05): "Safety of laser products"

These products are safe under reasonably foreseeable conditions of operation and are not harmful to the eyes provided that the products are used and maintained in accordance with this User Manual.

Description	Value
Wavelength	658 nm
Pulse duration	800 ps
Pulse repetition frequency (PRF)	100 MHz
Maximum average radiant power	0.33 mW
Beam divergence	1.5 mrad × 3 mrad

Locations of laser exit apertures

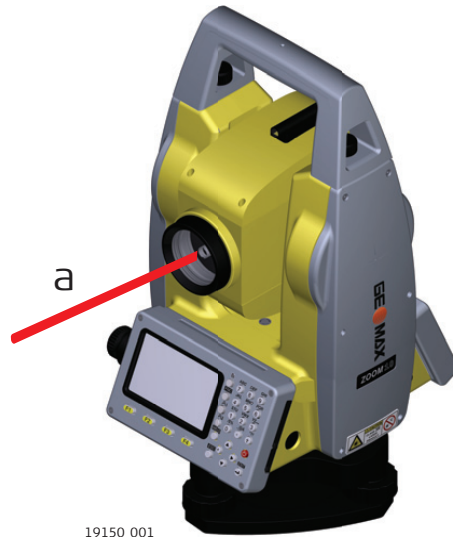

a Laser beam

1.6.3

Distancer, Measurements without Reflectors (NP mode)

General

The EDM module built into the product produces a visible laser beam which emerges from the telescope objective.

The laser product described in this section is classified as laser class 3R in accordance with:

- IEC 60825-1 (2014-05): "Safety of laser products"

Direct intrabeam viewing may be hazardous (low eye hazard level), in particular for deliberate ocular exposure. The beam may cause dazzle, flash-blindness and after-images, particularly under low ambient light conditions. The risk of injury for laser class 3R products is limited because of:

- a) unintentional exposure would rarely reflect worst case conditions of (e.g.) beam alignment with the pupil, worst case accommodation,
- b) inherent safety margin in the maximum permissible exposure to laser radiation (MPE)
- c) natural aversion behaviour for exposure to bright light for the case of visible radiation.

Description	Value
Maximum average radiant power	4.8 mW
Pulse duration	400 ps
Pulse repetition frequency	320 MHz
Wavelength	658 nm
Beam divergence	0.2 mrad x 0.3 mrad
NOHD (Nominal Ocular Hazard Distance) @ 0.25 s	46 m / 151 ft

 **CAUTION**

Class 3R laser products

From a safety perspective, class 3R laser products should be treated as potentially hazardous.

Precautions:

- ▶ Prevent direct eye exposure to the beam.
- ▶ Do not direct the beam at other people.

 **CAUTION**

Reflected beams aimed at reflecting surfaces

Potential hazards are not only related to direct beams but also to reflected beams aimed at reflecting surfaces such as prisms, windows, mirrors, metallic surfaces, etc.

Precautions:

- ▶ Do not aim at areas that are essentially reflective, such as a mirror, or which could emit unwanted reflections.
- ▶ Do not look through or beside the optical sight at prisms or reflecting objects when the laser is switched on, in laser pointer or distance measurement mode. Aiming at prisms is only permitted when looking through the telescope.

Locations of laser exit apertures

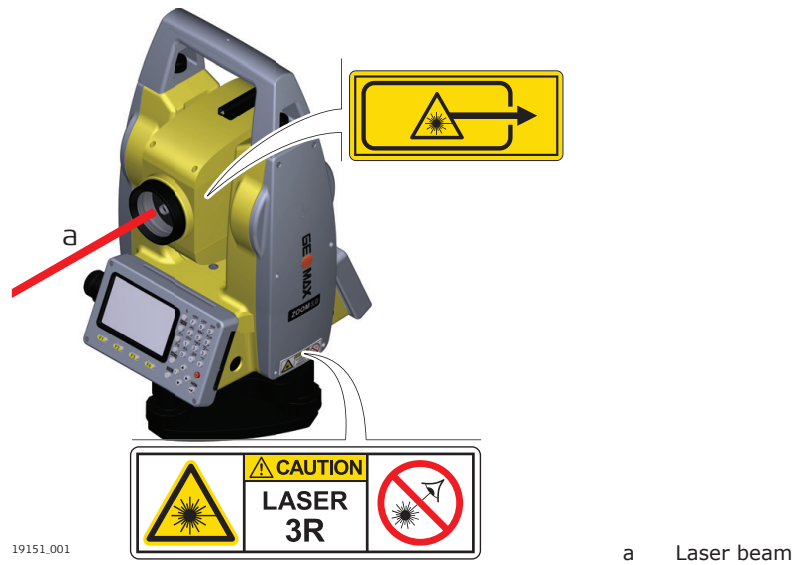

1.6.4

Laser Plummet

General

The laser plummet built into the product produces a visible red laser beam which emerges from the bottom of the product.

The laser product described in this section is classified as laser class 2 in accordance with:

- IEC 60825-1 (2014-05): "Safety of laser products"

These products are safe for momentary exposures but can be hazardous for deliberate staring into the beam. The beam may cause dazzle, flash-blindness and after-images, particularly under low ambient light conditions.

Description	Value
Maximum radiant power	0.95 mW ± 5%
Duty cycle	14%, 22%, 35%, 70%
Pulse repetition frequency	1 kHz
Beam divergence	< 1.5 mrad
Beam diameter at aperture (1/e)	2.0 mm x 1.5 mm

CAUTION

Class 2 laser product

From a safety perspective, class 2 laser products are not inherently safe for the eyes.

Precautions:

- ▶ Avoid staring into the beam or viewing it through optical instruments.
- ▶ Avoid pointing the beam at other people or at animals.

Locations of laser exit apertures

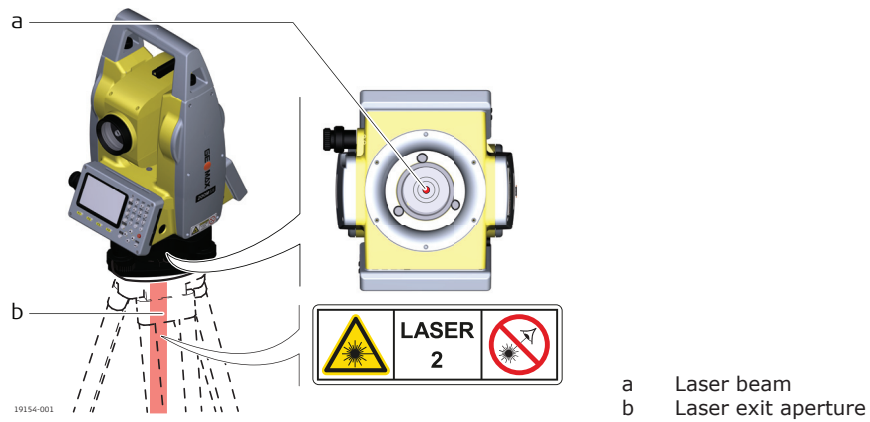

1.7

Electromagnetic Compatibility (EMC)

Description

The term Electromagnetic Compatibility is taken to mean the capability of the product to function smoothly in an environment where electromagnetic radiation and electrostatic discharges are present, and without causing electromagnetic disturbances to other equipment.

WARNING

Electromagnetic radiation

Electromagnetic radiation can cause disturbances in other equipment.

Precautions:

- ▶ Although the product meets the strict regulations and standards which are in force in this respect, GeoMax cannot completely exclude the possibility that other equipment may be disturbed.

CAUTION

Use of the product with accessories from other manufacturers. For example field computers, personal computers or other electronic equipment, non-standard cables or external batteries

This may cause disturbances in other equipment.

Precautions:

- ▶ Use only the equipment and accessories recommended by GeoMax.
- ▶ When combined with the product, they meet the strict requirements stipulated by the guidelines and standards.
- ▶ When using computers, two-way radios or other electronic equipment, pay attention to the information about electromagnetic compatibility provided by the manufacturer.

CAUTION

Intense electromagnetic radiation. For example, near radio transmitters, transponders, two-way radios or diesel generators

Although the product meets the strict regulations and standards which are in force in this respect, GeoMax cannot completely exclude the possibility that function of the product may be disturbed in such an electromagnetic environment.

Precautions:

- ▶ Check the plausibility of results obtained under these conditions.

⚠ CAUTION

Electromagnetic radiation due to improper connection of cables

If the product is operated with connecting cables attached at only one of their two ends, for example external supply cables, interface cables, the permitted level of electromagnetic radiation may be exceeded and the correct functioning of other products may be impaired.

Precautions:

- ▶ While the product is in use, connecting cables, for example product to external battery, product to computer, must be connected at both ends.

1.8

FCC Statement, Applicable in U.S.



The greyed paragraph below is only applicable for products without radio.

⚠ WARNING

This equipment has been tested and found to comply with the limits for a Class A digital device, pursuant to Part 15 of the FCC Rules. These limits are designed to provide reasonable protection against harmful interference when the equipment is operated in a commercial environment. This equipment generates, uses, and can radiate radio frequency energy and, if not installed and used in accordance with the instruction manual, may cause harmful interference to radio communications. Operation of this equipment in a residential area is likely to cause harmful interference in which case the user will be required to correct the interference at his own expense.

⚠ CAUTION

Changes or modifications not expressly approved by GeoMax for compliance could void the user's authority to operate the equipment.

Label placement on the Zoom10

*Complies with FDA performance standards for laser products except for deviations pursuant to Laser Notice No. 50, dated June 24, 2007.
This device complies with part 15 of the FCC Rules. Operation is subject to the following two conditions:
(1) This device may not cause harmful interference, and
(2) this device must accept any interference received, including interference that may cause undesired operation.*

**P_{av} = 4.8mW λ = 658nm t_p = 400ps
IEC 60825-1:2014**

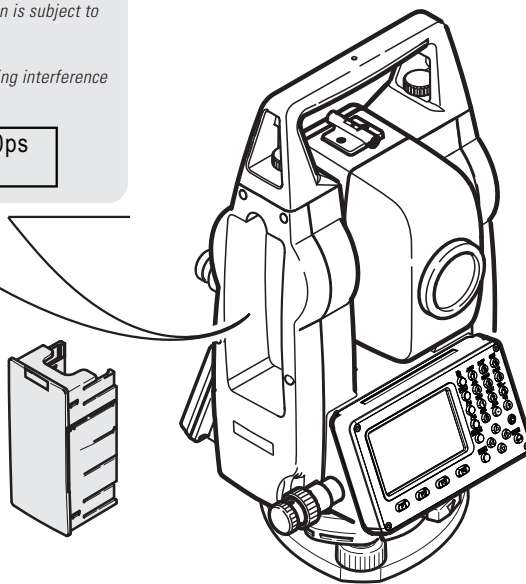

19152_001

Label placement on the internal battery ZBA10

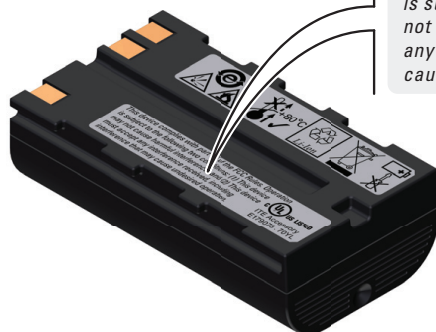

This device complies with part 15 of the FCC Rules. Operation is subject to the following two conditions: (1) This device may not cause harmful interference, and (2) this device must accept any interference received, including interference that may cause undesired operation.

19153_001

1.9

ISED Statement, Applicable in Canada

WARNING

This device complies with Industry Canada's licence-exempt RSSs. Operation is subject to the following two conditions:

1. This device may not cause interference; and
2. This device must accept any interference, including interference that may cause undesired operation of the device.

Radio Frequency (RF) Exposure Compliance Statement

The radiated RF output power of the instrument is below the Health Canada's Safety Code 6 exclusion limit for portable devices (radiated element separation distance between the radiating element and user and/or bystander is below 20 cm).

2

Description of the System

2.1

System Components

Main Components

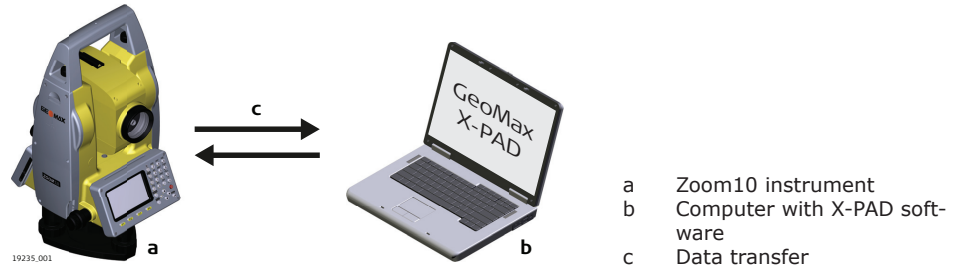

Component	Description
Zoom10 instrument	An instrument for measuring, calculating and capturing data. Ideally suited for tasks from simple surveys to complex applications. The instrument can be connected with X-PAD to view, exchange and manage data.
Firmware	The firmware package installed on the instrument. Consists of a standard base operating system.
X-PAD software	An office software consisting of a suite of standard programs for the viewing, exchanging, managing and post-processing of data.
Data transfer	Data can be always transferred between the instrument and a computer using a data transfer cable, a UDisk or Bluetooth connection.  Bluetooth connection can only be established from within the Q-Survey application.

2.2

Delivery Contents

Delivery contents

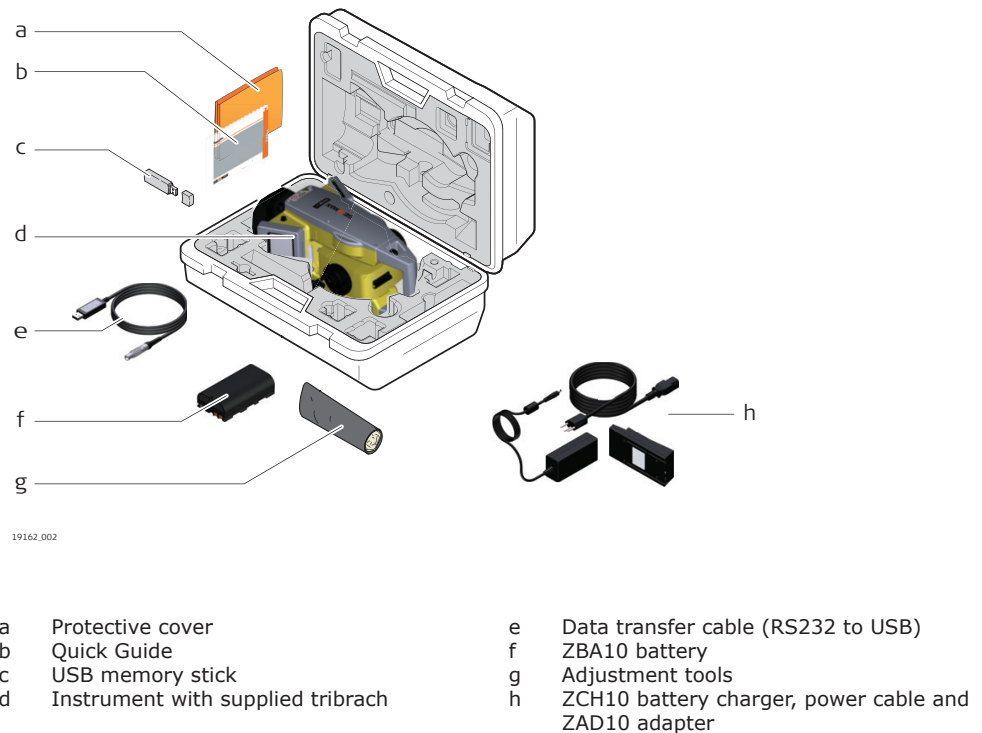

2.3

Instrument Components

Instrument components part 1 of 2

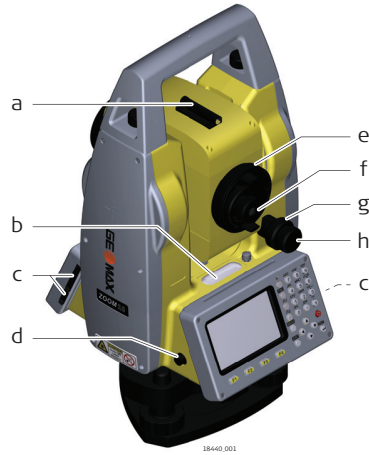

- a Optical sight
- b Levelling bubble
- c Ports for SD card and mini USB
- d RS232C port
- e Focusing telescope image
- f Eyepiece; focusing graticule
- g Clamping screw
- h Vertical drive

Instrument components part 2 of 2

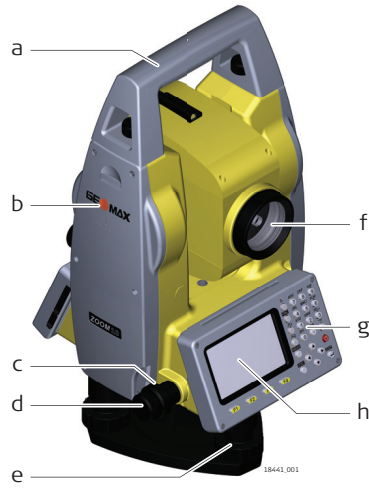

- a Detachable carrying handle with mounting screw
- b Battery cover
- c Clamping screw
- d Horizontal drive
- e Footscrew
- f Objective with integrated Electronic Distance Measurement (EDM). Exit for laser beam.
- g Keyboard
- h Display

3

User Interface

3.1

Keyboard

Alphanumeric keyboard

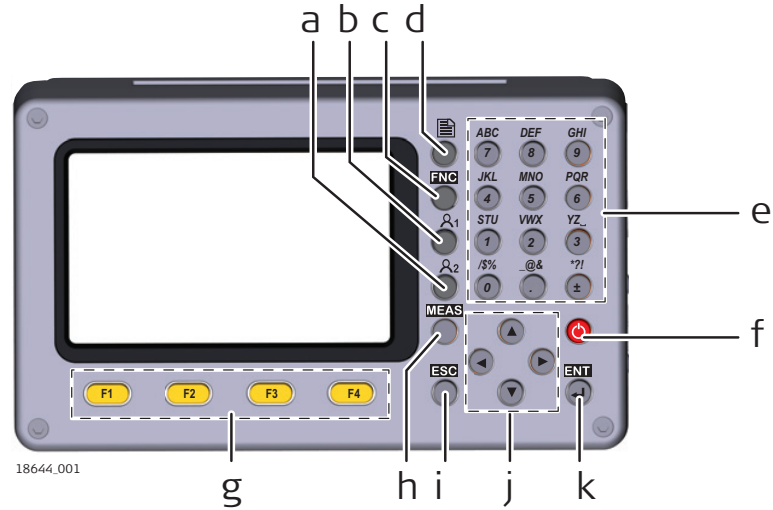







18644_001

- | | | | |
|---|---------------------|---|---------------------------------------|
| a | User Key2 | g | Function keys F1 to F4 |
| b | User Key1 | h | MEAS key |
| c | FNC key | i | ESC key |
| d | PAGE key | j | LEFT/RIGHT, UP/DOWN arrow keys |
| e | Alphanumeric keypad | k | ENT key |
| f | On/Off key | | |

Keys

Key	Description																								
<table border="0"> <tr> <td>ABC</td> <td>DEF</td> <td>GHI</td> </tr> <tr> <td>7</td> <td>8</td> <td>9</td> </tr> <tr> <td>JKL</td> <td>MNO</td> <td>PQR</td> </tr> <tr> <td>4</td> <td>5</td> <td>6</td> </tr> <tr> <td>STU</td> <td>VWX</td> <td>YZ_</td> </tr> <tr> <td>1</td> <td>2</td> <td>3</td> </tr> <tr> <td>/S%</td> <td>_@&</td> <td>*?! </td> </tr> <tr> <td>0</td> <td>.</td> <td>±</td> </tr> </table>	ABC	DEF	GHI	7	8	9	JKL	MNO	PQR	4	5	6	STU	VWX	YZ_	1	2	3	/S%	_@&	*?!	0	.	±	Editable fields: To enter text and numerical values. Menu screen: To select a menu element by number.
ABC	DEF	GHI																							
7	8	9																							
JKL	MNO	PQR																							
4	5	6																							
STU	VWX	YZ_																							
1	2	3																							
/S%	_@&	*?!																							
0	.	±																							
	PAGE key. Displays the next screen when several screens are available.																								
	User Key1/User Key2 User-definable keys that can be assigned to a function of the function menu for quick access.																								
	ON/OFF key. To turn off instrument, press for 2 s, then press ENT key.																								

Key	Description
	MEAS key. Functionality varies depending on key setting and screen context: <ul style="list-style-type: none"> • Measure distance and save • Measure distance • None
	LEFT/RIGHT, UP/DOWN arrow keys to navigate or to move cursor.
	ESC key. Quits a screen or edit mode without saving changes. Returns to next higher level.
	FNC key. Quick access to measurement supporting functions.
	ENT key. Editable fields: Confirms an entry and continues to the next field. Menu screen: Opens a selected menu element.
	Function keys that are assigned to the variable functions displayed at the bottom of the screen (softkeys).

3.2

Screen

Screen

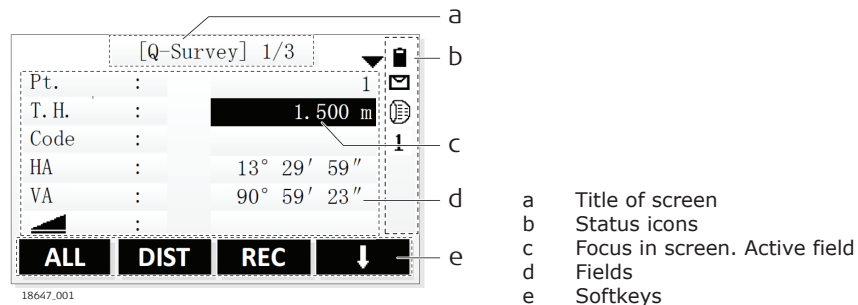

All shown screens are examples. It is possible that local firmware versions are different to the basic version.



3.3

Status Icons

Description

The icons provide status information related to basic instrument functions. Depending on the firmware version, different icons may be displayed.

Icons

Icon	Description
	Battery level is sufficient for operating.
	Battery power will last for 4 hours of operating time.

Icon	Description
	Battery level running low. End operating and replace or charge the battery.
	Battery level is critically low. Instrument shuts down automatically within a few minutes.
	Compensator is on.
	Compensator is off.
	EDM setting Reflector is set to Prism . Mode for measuring to prisms.
	EDM setting Reflector is set to Non-Prism . Mode for measuring to all targets.
	EDM setting Reflector is set to Sheet . Mode for measuring to reflector sheet.
1	EDM Mode is set to Single .
R	EDM Mode is set to Repeat .
T	EDM Mode is set to Tracking .
3	EDM Mode is set to 3 Times .
4	EDM Mode is set to 4 Times .
5	EDM Mode is set to 5 Times .
	A double arrow indicates that a field has a selectable list. Press the LEFT/RIGHT keys to toggle through the list.
	Up and down arrows indicate that several screens are available. Press the PAGE key to toggle through the screens.
	Look forward from station and move prism to left.
	Look forward from station and move prism to right.
	Lower prism.
	Raise prism.

3.4

Softkeys

Description

Softkeys are selected using the relevant **F1** to **F4** function key. This chapter describes the functionality of the common softkeys used by the system. The more specialised softkeys are described where they appear in the program chapters.

Common softkey functions

Key	Description
Alpha	To change the keypad operation to alphanumerical.
Digit.	To change the keypad operation to numerical.
ALL	To start distance and angle measurements and save the measured values.
DIST	To start distance and angle measurements without saving the measured values.
REC	To save the displayed values.
Back	To return to the last active screen.
OK	If entry screen: Confirms measured or entered values and continues the process. If message screen: Confirms message and continues with selected action or returns to the previous screen to reselect an option.
Coord.	To open the manual coordinate entry screen.
EDM	To view and change EDM settings. Refer to "5.2 EDM Settings".
List	To display the list of available points.
Reset	To reset all editable fields to their default values.
B.S.	To delete character left of the cursor position.

Key	Description
Clear	To delete all characters in the field.
Find	To search for an entered point.
View	To display the coordinate and job details of the selected point.
	If more than one softkey level is available: To toggle through the softkey levels.

3.5

Operating Principles

Turn instrument on/off



Use the On/Off key.

Alphanumeric keypad

The alphanumeric keypad is used to enter characters directly into editable fields.

- **Numeric fields:** Can only contain numerical values. By pressing a key of the keypad the number is displayed.
- **Alphanumeric fields:** Can contain numbers and letters. By pressing a key of the keypad the first character written above that key is displayed. To toggle through the characters, press several times. For example: 1->S->T->U->1->S...

Switching between alphanumeric and numeric mode

- When alphanumeric mode is active, the status icon  is displayed. To switch to numeric mode, press softkey **Digit**(F4).
- When numeric mode is active, the status icon  is displayed. To switch to alphanumeric mode, press softkey **Alpha**(F4).

Edit fields

- Press **ENT** to start editing.
- Press **ENT** to confirm input after editing. Focus in screen moves to next editable field.
- When editing distance, angle, temperature or pressure values with units, the editable field only displays numbers without units. After confirming with **ENT**, the units are displayed again.
Example: **29° 32' 56"** changes to **29.3256** in edit mode.
- Use left and right arrow key to move the cursor within the editable field.
- To delete the character left of the cursor position, press softkey **B.S.** (F1).
- To delete all characters in the editable field, press softkey **Clear** (F2).



ESC undoes any changes.



The number of decimal places displayed for distance fields depends on the setting for "Dist. Decimal" (refer to "Dist. Decimal"). This setting is for data display and does not apply to data export or storage. In edit mode, you can enter more decimal places than actually displayed.

Special characters

Character	Description
*	Used as wildcards in search fields for point numbers or codes. Refer to "3.6 Pointsearch".
+/-	In the alphanumeric character set "+" and "-" are treated as normal alphanumeric characters with no mathematical function.  "+" / "-" only appear in front of an entry.

Selection by number

[Function]		1/3	▼
F1	Level	(1)	
F2	Offset	(2)	
F3	NP/P	(3)	
F4	HT. Transfer	(4)	

F1 | F2 | F3 | F4

In this example, pressing 2 on the alphanumeric keypad opens the screen for setting the distance offset.

3.6

Pointsearch

Description

Pointsearch is a function used by applications to find measured or fixed points in the memory storage.

The pointsearch is limited to the current job. It is not possible to search the whole storage.

Direct search

By entering an actual point number, for example A1, and pressing softkey **Find**, all points within the current job and with the corresponding point number are found.

Example: Search for a station point

[Set STA]	
Input STA PT!	
Station :	A1

Find | List | Coord. |

Find To search for matching points within the current job.

Search result

[Find Pt.]		1/5
A1	Station	
A1	Station	
A1	Meas. PT	
A1	Meas. PT	
A1	Fix Pt.	

View | Coord. | Job | OK

Use the **UP/DOWN** keys to select a point in the search result list.

View To display the coordinate and job details of the selected point.

Coord. To create a point by entering point coordinates manually.

Job To search for points within another job.

OK To confirm the selected point .

Wildcard search

The wildcard search is indicated by a "*". The asterisk is a place holder for any following sequence of characters. Wildcards should be used if the point number is not fully known, or to search for a batch of points.

Examples of point searches

- * All points are found.
- A All points with exactly the point number "A" are found.
- A* All points starting with "A" are found, for example, A9, A15, ABCD, A2A.

4

Operation

4.1

Working with the Battery

Charging / first-time use

- The battery must be charged prior to using it for the first time because it is delivered with an energy content as low as possible.
- The permissible temperature range for charging is between 0°C to +40°C/+32°F to +104°F. For optimal charging we recommend charging the batteries at a low ambient temperature of +10°C to +20°C/+50°F to +68°F if possible.
- It is normal for the battery to become warm during charging. Using the chargers recommended by GeoMax, it is not possible to charge the battery if the temperature is too high.
- For new batteries or batteries that have been stored for a long time (> three months), it is effectual to make only one charge/discharge cycle.
- For Li-Ion batteries, a single discharging and charging cycle is sufficient. We recommend carrying out the process when the battery capacity indicated on the charger or on a GeoMax product deviates significantly from the actual battery capacity available.

Change the battery step-by-step

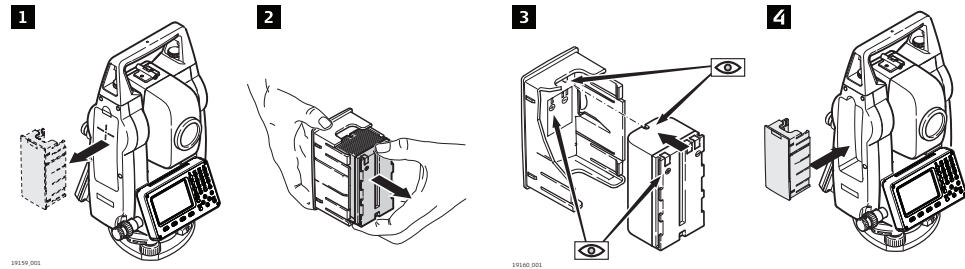

1. Remove the battery holder from the instrument.
2. Remove the battery from the battery holder.
3. Insert the new battery into the battery holder, ensuring that the contacts are facing outward. The battery should click into position.
4. Insert the battery holder back into the battery compartment.

4.2

Instrument Setup

Description

This topic describes an instrument setup over a marked ground point using the laser plummet. It is always possible to set up the instrument without the need for a marked ground point.



Important features

- It is always recommended to shield the instrument from direct sunlight and avoid uneven temperatures around the instrument.
- The laser plummet described in this topic is built into the vertical axis of the instrument. It projects a red spot onto the ground, making it appreciably easier to centre the instrument.

Tripod

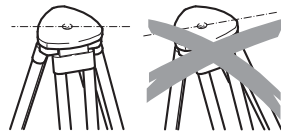

When setting up the tripod pay attention to ensuring a horizontal position of the tripod plate. Slight corrections of inclination can be made with the foot screws of the tribrach. Larger corrections must be done with the tripod legs.

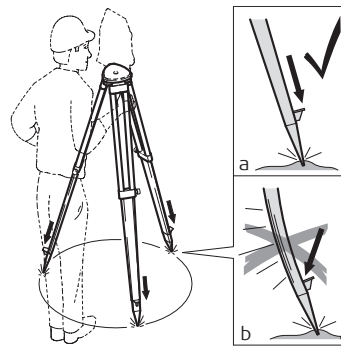

Loosen the clamping screws on the tripod legs, pull out to the required length and tighten the clamps.

- a In order to guarantee a firm foothold sufficiently press the tripod legs into the ground.
- b When pressing the legs into the ground note that the force must be applied along the legs.

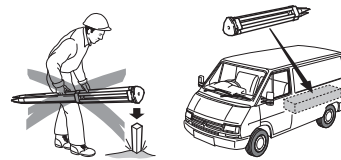

Careful handling of tripod.

- Check all screws and bolts for correct fit.
- During transport always use the cover supplied.
- Use the tripod only for surveying tasks.

Setup step-by-step

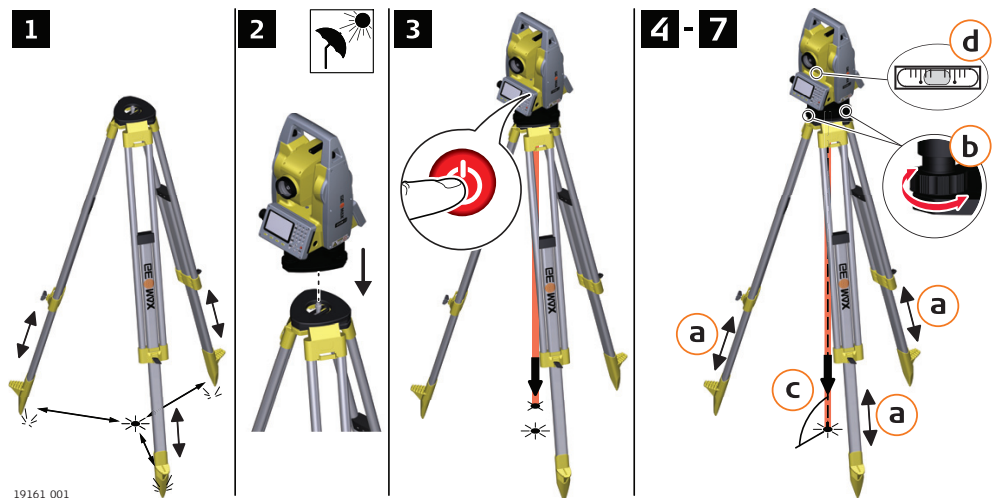

19161.001



Insert the battery before setting up the instrument. When inserting the battery after setup, the instrument may tilt slightly.

1. Extend the tripod legs to allow for a comfortable working posture. Position the tripod over the marked ground point, centring it as best as possible.
2. Fasten the tribrach and instrument onto the tripod.
3. Turn on the instrument. To switch on the laser plummet, press **FNC** from within any application and select **Level**.
4. Move the tripod legs (a) and use the tribrach footscrews (b) to centre the plummet over the ground point (c).
5. Turn the instrument until the tubular level is parallel to two footscrews. Adjust the tripod legs (a) to level the tubular level (d).

6. To level the instrument precisely, use the electronic level:
 - Centre the electronic level of the first axis by turning two footscrews.
 - Centre the electronic level for the second axis by turning the last footscrew.
 - Accept with **OK**.

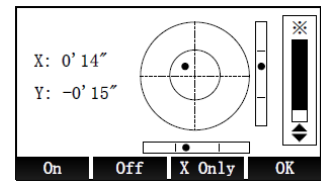

7. Centre the instrument precisely over the ground point by shifting the tribrach on the tripod plate.



When the electronic level is centred and both axes are within the tolerance limit, the instrument has been levelled up.



Repeat steps 6. and 7. until the required accuracy is achieved.



If the instrument is used on an unstable base, for example a shaking platform or ship, deactivate the compensator. Otherwise, the compensator might drift out of its measuring range and interrupt the measuring process by indicating an error.

Position over pipes or holes

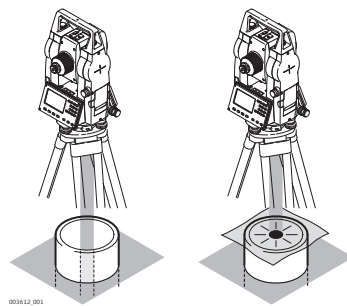

Under some circumstances the laser dot is not visible, for example over pipes. In this case, using a transparent plate enables the laser dot to be seen and then easily aligned to the center of the pipe.

4.3

Data Storage

Description

An internal memory is included in all instruments. The firmware stores all data in jobs in a database in the internal memory. Data can then be transferred to a computer or other device for post processing via a cable connected to the USB port.

Refer to "10 Data Management" for further information on data management and data transfer.

4.4

Main Menu

Description

The **Main Menu** is the starting place for accessing most functionality of the instrument. It is the first screen displayed after switching on the instrument.

Main menu

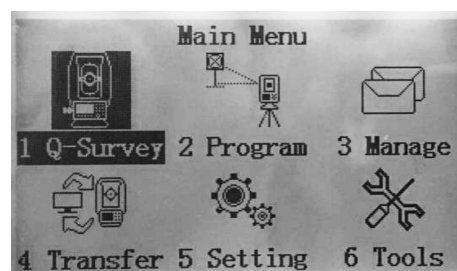

Description of the Main Menu functions

Function	Description
Q-Survey	To start measuring immediately. Refer to "4.5 Quick-Survey Application".
Program	To select and start applications. Refer to "8 Applications - Getting Started".
Manage	To manage jobs, data, codelists, system memory and USB memory stick files. Refer to "10 Data Management".
Transfer	To export/import data. Refer to "11 Data Transfer".
Setting	To change EDM configurations and general instrument settings. Refer to "5 Settings".
Tools	To access instrument-related tools such as check and adjust, system information or firmware upgrade. Refer to "6 Tools".

4.5

Quick-Survey Application

Description

After switching on, the instrument is immediately ready for measuring.

Access

Select **Q-Survey (1)** from the Main Menu.

Q-Survey screens

Q-Survey has three screens and three softkey levels. The screens include all commonly used measuring functions, such as angle measurement, distance measurement and coordinate measurement.

- To toggle through the available softkey levels press **F4**.
- To toggle through the available screens press the **PAGE** key.

- ALL** To start distance and angle measurements and save the measured values.
- DIST** To start distance and angle measurements without saving the measured values.
- REC** To save the displayed values.

- ALL** To start distance and angle measurements and save the measured values.
- Code** To display the screen for selecting or editing codes. Refer to "7.5 Coding".
- EDM** To edit the EDM settings. Refer to "5.2 EDM Settings".

- Station** To set the station coordinates. Refer to "Set the station coordinates (Q-Survey)".
- Zero** To set the horizontal angle to zero. Refer to "Set the station orientation (Q-Survey)".
- SetHA** To set the horizontal angle to the desired value. Refer to "Set the station orientation (Q-Survey)".

Set the station coordinates (Q-Survey)



All measurements and coordinate computations are referenced to the set station coordinates.

The station coordinates that are set must include:

- at least grid coordinates (E, N), and
- the station height, if necessary.

In Q-Survey, the coordinates can be entered manually only.

1. In Q-Survey, press **F4** twice to display the third softkey level. Press the softkey **Station** (F1).

[Q-Survey] 3/3	
Pt. :	A1
T.H. :	1.500 m
Code :	1
N :	9.829 m
E :	2.360 m
Z :	-0.275 m
Station Zero SetHA ←	

2. *The screen "Input STA" is displayed.*
 - Enter the name of the station, the instrument height and the coordinates.
 - To save the station data and return to Q-Survey, press **OK** (F4).
 - To cancel and return to Q-Survey, press **ESC**.

[Input STA]	
Station :	DEFAULT
I.H. :	1.000 m
X0/NO :	0.000 m
Y0/E0 :	0.000 m
Z0/H0 :	0.000 m
OK	

Set the station orientation (Q-Survey)

Set the horizontal angle to zero

1. In Q-Survey, press **F4** twice to display the third softkey level. Press the softkey **Zero** (F2).

[Q-Survey] 3/3	
Pt. :	A1
T.H. :	1.500 m
Code :	1
N :	9.829 m
E :	2.360 m
Z :	-0.275 m
Station Zero SetHA ←	

2. *The screen "Set HA=0?" is displayed.*
 - To set the horizontal angle to zero and return to Q-Survey, press **Yes** (F4).
 - To cancel and return to Q-Survey, press **No** (F1).

Set HA=0?	
No Yes	

Set the horizontal angle to any desired value



You can either enter the desired value manually or use the current orientation of the instrument. Aim the instrument at the desired target point to set the orientation.

1. In Q-Survey, press **F4** twice to display the third softkey level. Press the softkey **SetHA** (F3).

[Q-Survey] 3/3	
Pt. :	A1
T.H. :	1.500 m
Code :	1
N :	9.829 m
E :	2.360 m
Z :	-0.275 m
Station Zero SetHA ←	

2. The current value of the horizontal angle is displayed in the screen "SetHA".
 - To set the horizontal angle to the current value and return to Q-Survey, press **OK** (F4).
 - To edit the horizontal angle, press **ENT**. Enter any desired value.
 - To set the horizontal angle to zero, press **Zero** (F1).
 - To save changes and return to Q-Survey, press **OK** (F4). To cancel and return to Q-Survey, press **ESC**.

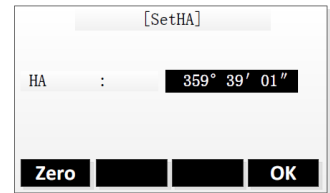

Measure (Q-Survey)

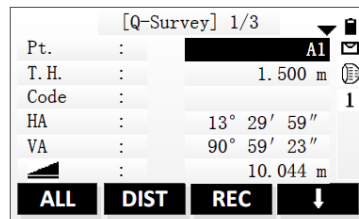

Field	Description
Pt.	Point ID of the point
T.H.	Reflector height
Code	Code name. This text is stored with the corresponding measurement.

1. Enter a point ID and the reflector height.
 - ☞ If necessary, enter a code name or select a code from the code library.
 - Codes entered manually are not added to the code library.
 - To select a code from the code library, press **F4** and select **Code** from the second softkey level. Refer to "7.5 Coding".
 - If the code setting is set to "Permanent", the code is applied to all further measurements automatically. Refer to "Code"(within 5.1).
2. Aim at the target point.
 - To start measuring and save the measured values, press **ALL** or **DIST+REC**.
 - To toggle through the measurement result screens, press the **PAGE** key.
 - After a measurement the instrument automatically increments the point ID.
3. Repeat the previous step to measure another point.
4. To exit the application, press **ESC**.

4.6

Distance Measurements - Guidelines for Correct Results

Description

A laser distancer (EDM) is incorporated into the Zoom10 instruments. In all versions, the distance can be determined by using a visible red laser beam which emerges coaxially from the telescope objective. There are two EDM modes:

- Prism measurements (P)
- Reflectorless measurements (NP)

NP measurements

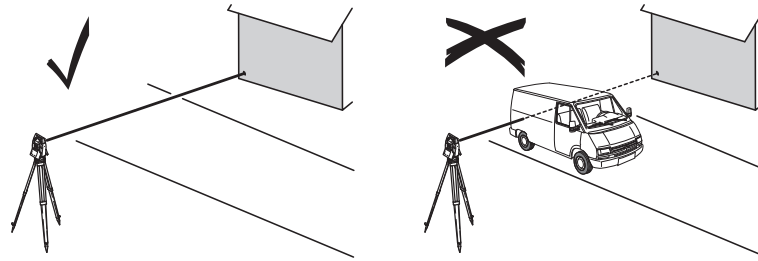

- When a distance measurement is triggered, the EDM measures to the object which is in the beam path at that moment. If a temporary obstruction, for example a passing vehicle, heavy rain, fog or snow is between the instrument and the point to be measured, the EDM may measure to the obstruction.
- Be sure that the laser beam is not reflected by anything close to the line of sight, for example highly reflective objects.
- Avoid interrupting the measuring beam while taking reflectorless measurements or measurements using reflective foils.
- Do not measure with two instruments to the same target simultaneously.

P measurements

- Accurate measurements to prisms should be made in P-Standard mode.
- The prism mode also supports measurements to targets which are not a prism. However, accuracy is not guaranteed.
- Measurements to strongly reflecting targets such as traffic lights in Prism mode without a prism should be avoided. The measured distances may be wrong or inaccurate.
- When a distance measurement is triggered, the EDM measures to the object which is in the beam path at that moment. If for example people, cars, animals, or swaying branches cross the laser beam while a measurement is being taken, a fraction of the laser beam is reflected from these objects and may lead to incorrect distance values.
- Measurements to prisms are only critical if an object crosses the measuring beam at a distance of 0 to 30 m and the distance to be measured is more than 300 m.
- In practice, because the measuring time is very short, the user can always find a way of avoiding unwanted objects from interfering in the beam path.

Red laser to reflector foil

- The visible red laser beam can also be used to measure to reflective foils. To guarantee the accuracy the red laser beam must be perpendicular to the reflector foil and it must be well adjusted.
- Make sure the additive constant belongs to the selected target (reflector).

5

Settings

5.1

General Settings

Access

1. Select **Setting** from the Main Menu.
2. Select **General** from the Setting menu.
3. Press the **PAGE** key to scroll through the screens of available settings.

General settings

Example: Screen 1/4

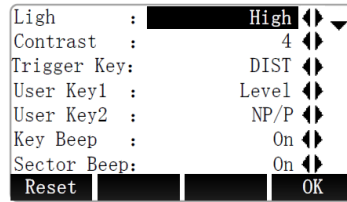

Reset To reset settings to the default values.
OK To save changes and return to previous screen.



To toggle through the available screens press the **PAGE** key.

Screen 1/4

Field	Description	
Light	Off, Low, Medium, High	Sets the level of screen illumination.
Contrast	1 (low) to 9 (high)	Sets the display contrast in steps from 1 to 9.
Trigger Key	Off	MEAS key is disabled.
	ALL	Functionality of MEAS key is set to "Measure distance and save".
	DIST	Functionality of MEAS key is set to "Measure distance".
User Key1/User Key2	Level, Offset, NP/P, HT, Transfer, Hidden Point, Free Coding, Laser, Light, Unit Setting, Main Setting, EDM Tracking	Assigns the selected functionality of the function menu to the key
Key Beep		The beep is an acoustic signal after each key stroke.
	On	Beep is enabled.
	Off	Beep is disabled.
Sector Beep	On	Beep sounds at right angles (0°, 90°, 180°, 270° or 0, 100, 200, 300 gon).
	Off	Beep is disabled.

Screen 2/4

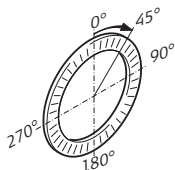
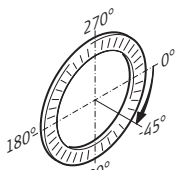
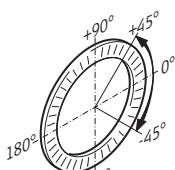
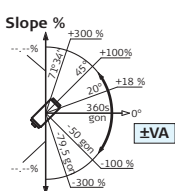
Field	Description	
Tilt	On	Tilt sensor is enabled for X and Y axis.
	Off	Tilt sensor is disabled.
	X Only	Tilt sensor is enabled for X axis only.
Hz Increment	Right	Set measurement of horizontal angle to clockwise direction.
	Left	Set measurement of horizontal angle to anticlockwise direction.

Field	Description
V-Setting	Sets the vertical angle
Zenith	Zenith=0°; Horizon=90°.
	
Horiz.0	Zenith=270°; Horizon=0°.
	
Vert.90	Zenith=90°; Horizon=0°. Vertical angles are positive above the horizon and negative below it.
	
Slope	Zenith=45°=100%; Horizon=0°. Vertical angles are expressed in % with positive above the horizon and negative below it.
	
	The % value increases rapidly. --.--% appears on the display above 300%.
Angle Unit	Sets the units shown for all angular fields.
	° ' " Degree sexagesimal. Possible angle values: 0° to 359°59'59"
	Gon Gon. Possible angle values: 0 gon to 399.999 gon
	Mil Mil. Possible angle values: 0 to 6399.99mil.
	 The setting of the angle units can be changed at any time. The actual displayed values are converted according to the selected unit.
Min. Reading	Sets the number of decimal places shown for all angular fields. This is for data display and does not apply to data export or storage.
	° ' " 1" /5"/10"
	Gon 0.0002 / 0.001 / 0.002
	Mil 0.005 / 0.02 / 0.05
Dist. Unit	Sets the units shown for all distance and coordinate related fields.
	Metre Metres [m].
	US-ft US feet [ft].
	INT-ft International feet [fi].

Field	Description	
	ft-in1/8	US feet-inch-1/8 inch [ft].
Dist. Decimal	Sets the number of decimal places shown for all distance fields. This setting is for data display and does not apply to data export or storage.	
	3	Distance with three decimals.
	4	Distance with four decimals.

Screen 3/4

Field	Description	
Temp. Unit	Sets the units shown for all temperature fields.	
	°C	Degree Celsius.
	°F	Degree Fahrenheit.
Press. Unit	Sets the units shown for all pressure fields.	
	hPA	Hecto Pascal.
	mmHG	Millimeter mercury.
	inHg	Inch mercury.
Code	Defines whether the code is used for one or for many measurements.	
	Rec/Reset	The code is cleared after saving a measurement with softkey ALL or REC.
	Permanent	The code is kept for all further measurements until it is deleted manually or until another code is selected.
Auto-Off	30min	The instrument switches off after 30 minutes without any activity
	Off	Automatic switch-off is deactivated.  Battery discharges quicker.
Port	RS232C	Communication is via the serial interface.
	Bluetooth	Communication is via Bluetooth.
Baudrate	9600, 19200, 115200	Sets the baudrate for the serial interface.
Coord. type	NEZ/ENZ	Sets the coordinate type.

Screen 4/4

Field	Description	
Language	Sets the software interface to the preferred language. Available languages: <ul style="list-style-type: none"> • English • Korean • French • Italian • Turkish • Spanish 	

5.2

EDM Settings

Description

The settings on this screen define the active EDM, **E**lectronic **D**istance **M**easurement. Different settings for measurements are available with Reflectorless (NP) and Prism (P) EDM modes.

Access

1. Select **Setting** from the Main Menu.
2. Select **EDM Setting** from the Setting menu.

EDM Setting

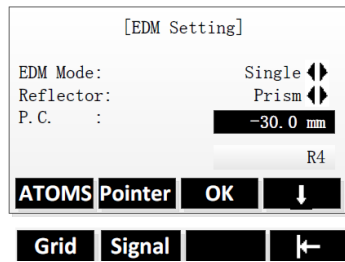

Softkey level 1:

- ATOMS** To enter atmospheric data ppm.
- Pointer** To switch the laser pointer on or off.
- OK** To save changes and return to previous screen.

Softkey level 2:

- Grid** To enter scale and altitude for scale correction.
- Signal** To display the intensity of the reflected EDM signal. This function helps you aiming at distant, barely visible, targets.

- To toggle through the available softkey levels press **F4**.
- To select a field for editing, press the **UP/DOWN** keys.
- To toggle through the available EDM modes or reflector types, press the **LEFT/RIGHT** keys.

Field	Description	
EDM Mode	Single	Quick measuring mode, with higher measuring speed and reduced accuracy.
	Repeat	Instrument repeatedly takes measurements until ESC key is pressed.
	Tracking	For continuous distance measurements.
	3 Times	Instrument takes three single measurements.
	4 Times	Instrument takes four single measurements.
	5 Times	Instrument takes five single measurements.
Reflector	Prism/Non-Prism	Set the reflector type. When using a prism, you also need to set the corresponding prism constant.
P.C.	Prism constant.	
		The entered prism constant is only effective when the reflector type is set to Prism. Input can only be made in mm. Limit value: -999.9 mm to +999.9 mm. Default value: 0 mm. The set prism constant is kept even when switching off the instrument.
Dist Mode	Standard	For standard measurements
	Long (>3 km)	For measurements over long distances

Atmospheric data

This screen enables the entry of atmospheric parameters. Distance measurement is influenced directly by the refractions of the air in which the measurements are taken. In order to take these influences into consideration distance measurements are corrected using atmospheric correction parameters. The refraction correction is taken into account in the calculation of the height differ-

ences and the horizontal distance. Refer to "14.6 Scale Correction" for the application of the values entered on this screen.

[Atomspheric Data]

Temp. : 20.0 °C

Press : 1013 hPa

PPM : 0.0 PPM

Refraction : 0.00

PPM=0 **OK**

PPM = 0 To set the PPM value to 0.
OK To save changes and return to previous screen.

Field	Description
Temp.	Enter the value of temperature. Allowed range is -30°C to 60°C.
Press	Enter the value of atmospheric pressure. Allowed range is 500h PA to 1400h PA.
PPM	The atmospheric correction parameter is calculated based on the entered temperature and pressure values.  When PPM = 0 is selected, the GeoMax standard atmosphere of 1013 hPa, 12°C, and 60% relative humidity is applied.
Refraction	0.00, 0.14, 0.20 Atmospheric refraction coefficient

Grid scale

This screen enables entry of the scale of projection. Coordinates are corrected with the PPM parameter. Refer to "14.6 Scale Correction" for the application of the values entered in this screen.

[Grid Scale]

Scale : 1.0000

Altitude: 0.000 m

Grid Scale 1.0000

Reset **OK**

Reset To reset settings to the default values.
OK To save changes and return to previous screen.

Field	Description
Scale	Enter the value of the scale factor. Allowed range is 0.99 to 1.01. The default value is 1.0.
Altitude	Enter the value of average height above sea level. Allowed range is -9999.9999 to 9999.9999.
Grid Scale	The grid scale value is calculated based on the entered temperature and pressure values.

6 Tools

6.1 Adjust

Description

The **Tools** menu contains tools to be used for the electronic calibration of the instrument. Using these tools helps to maintain the measuring accuracy of the instrument.

1. Select **Tools** from the Main Menu.
2. Select **Adjust** from the Tools menu.

For detailed information on calibration options, refer to "12 Check & Adjust".

6.2 System Information

Description

The System Information screen displays instrument, system and firmware information, as well as settings for the date and time.



Please provide the instrument-related information, such as instrument type, serial number and firmware version, when contacting support.

Access

1. Select **Tools** from the Main Menu.
2. Select **Info** from the Tools menu.

System information

This screen displays information about the instrument and operating system.

[Info.]			
Inst. Type:	HTS-420 series		
Inst. No. :	648164		
FW. Ver. :	V1.0 (20151103)		
Time :	13:42:28		
Date :	2015.11.12		
Date	Time	Upgrade	Back

Date To change the date.
Time To change the time.
Upgrade To upgrade the firmware.

Field	Description
Inst. Type	Displays the instrument type.
Inst. No.	Displays the serial number of the instrument.
FW. Ver.	Displays the version number of the firmware.
Time	Displays the time.
Date	Displays the date.

7

Functions

7.1

Overview

Description

Functions can be accessed by pressing **FNC** from any measurement screen. **FNC** opens the functions menu and a function can be selected and activated.



Functions

Function	Description
Level	Activates the laser plummet and electronic level. Refer to "Electronic level and laser plummet".
Offset	Starts the function Offset . Refer to "7.2 Offset".
NP/P	Changes between prism and non-prism mode.
HT. Transfer	Starts the function Height Transfer . Refer to "7.3 Height Transfer".
Hidden Point	Starts the function Hidden Point . Refer to "7.4 Hidden Point".
Free Coding	Refer to "7.5 Coding".
Laser	Activates/deactivates the visible laser beam for illuminating the target point.
Light	Activates and deactivates the screen illumination light.
Unit Setting	Allows to quickly change the units for angles, distances, temperature and pressure.
Main Setting	Allows to quickly change the most important hardware settings. For changing all settings, refer to "5.1 General Settings".
EDM Tracking	Activates/deactivates the EDM tracking mode.

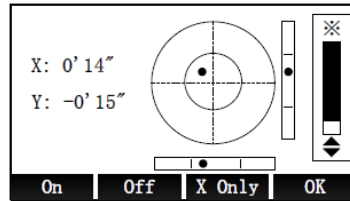
Electronic level and laser plummet



- On** To activate the compensator. Vertical angles refer to the plummet line, and the horizontal directions are corrected by the vertical-axis tilt.
- Off** To deactivate the compensator.
- X Only** To activate the compensator for X direction only. Vertical angles refer to the plummet line.
- OK** To turn off laser plummet and exit the electronic level screen.

-  The electronic level can be used to level up the instrument precisely using the foot-screws of the tribrach.
-  The laser plummet is turned on automatically when entering the electronic level screen. Press the **UP/DOWN** keys to adjust the brightness of the laser plummet.
-  If the instrument is used on an unstable base, for example a shaking platform or ship, deactivate the compensator. Otherwise, the compensator might drift out of its measuring range and interrupt the measuring process by indicating an error.

7.2

Offset

7.2.1

Distance Offset

Description

This function calculates the target point coordinates if it is not possible to set up the reflector, or to aim at the target point directly. The offset values (length, trav. and/or height offset) can be entered. The values for the angles and distances are calculated to determine the target point.

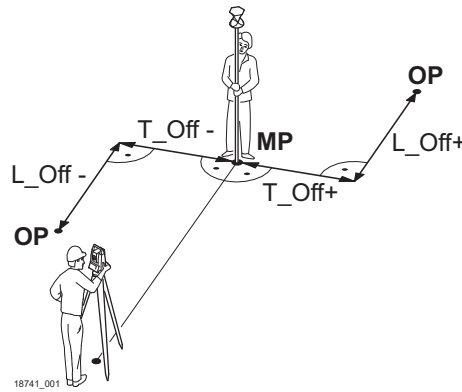

MP Measurement point
 OP Calculated offset point
 L_Off+ Length offset, positive
 L_Off- Length offset, negative
 T_Off+ Cross offset, positive
 T_Off- Cross offset, negative

Access

1. Press **FNC**.
2. Select **Offset** from the functions menu.

Distance offset

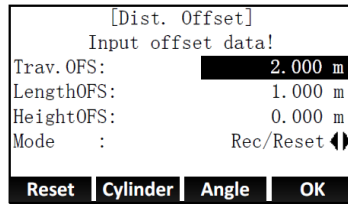

Reset To reset settings to the default values.
Cylinder To enter cylindrical offsets.
Angle To enter angle offsets.
OK To save changes and return to previous screen.

Field	Description
Trav.OFS	Perpendicular offset. Positive if the offset point is to the right of the measured point.
LengthOFS	Longitudinal offset. Positive if the offset point is further away than the measured point.
HeightOFS	Height offset. Positive if the offset point is higher than the measured point.
Mode	Period for which the offset is to apply.
	Rec/Reset The offset values are reset to 0 after the point is saved.
	Permanent The offset values are applied to all further measurements until the application is quit.

Next step

- Press **OK** and measure the distance. Confirm the measurement with **OK** to calculate the offset point.
- Or, press **Cylinder** to enter cylindrical offsets. Refer to "7.2.2 Cylindrical Offset".
- Or, press **Angle** to enter angle offsets. Refer to "7.2.3 Angle Offset".

7.2.2

Cylindrical Offset

Description

Determines the coordinates of the centre point of cylindrical objects and their radius. The horizontal angle to points on both the left and right sides of the object are measured, and the distance to the object as well.

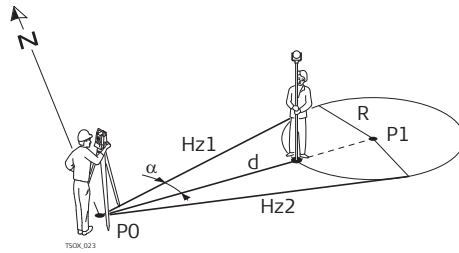

- P0 Instrument station
- P1 Centre point of cylindrical object
- H_{z1} Horizontal angle to a point on the left side of the object
- H_{z2} Horizontal angle to a point on the right side of the object
- d Distance to the object in the middle between H_{z1} and H_{z2}
- R Radius of cylinder
- α Azimuth from H_{z1} to H_{z2}

Access

1. Press **FNC**.
2. Select **Offset** from the functions menu.
3. Select **Cylinder** from the **Dist. Offset** menu.

Cylinder offset

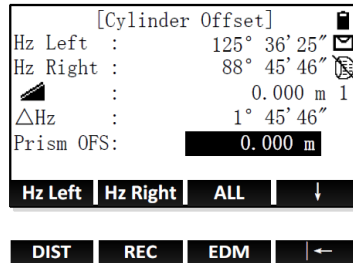

- Hz Left** To trigger measurement for the left side of the object.
- Hz Right** To trigger measurement for the right side of the object.

Field	Description
Hz Left	Measured horizontal direction to the left side of the object.
Hz Right	Measured horizontal direction to the right side of the object.
ΔHz	Deviation angle.
Prism OFS	Prism offset distance between the centre of the prism and the surface of the object to be measured. If the EDM mode is Non-Prism, the value is set to zero automatically.

Step by step

1. Using the vertical hair, aim at the left side of the object and press **Hz Left**.
2. Using the vertical hair, aim at the right side of the object and press **Hz Right**. Press OK to confirm the measurement.
3. Rotate the instrument to aim in the direction of the centre point of the cylindrical object, until Δ Hz is zero. If using a prism, enter the prism offset.
4. Once Δ Hz is zero, press **ALL** to complete the measurement and display the results.
The coordinates of the centre point are calculated and displayed.

Next step

- Press **DONE** to return to the previous screen.
- Or, press **New** to continue measuring with the Cylinder Offset function.

7.2.3

Angle Offset

Description

This function calculates the target point coordinates if it is not possible to set up the reflector, or to aim at the target point directly. The target point and the measurement point must have the same distance to the instrument.

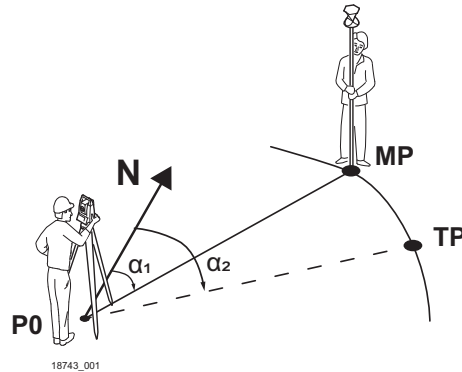

P0 Instrument station
 MP Measurement point
 TP Target point
 α_1 Horizontal angle of measured point
 α_2 Horizontal angle of target point

Access

1. Press **FNC**.
2. Select **Offset** from the functions menu.
3. Select **Angle** from the **Dist. Offset** menu.

Angle offset

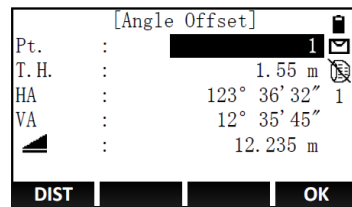

DIST To start distance and angle measurement.
OK To confirm the measurement and continue with next measurement.

Field	Description
HA	Horizontal angle.
VA	Vertical angle.
	Distance between instrument station and measured point.

Step by step

1. Aim at the measurement point and press **DIST**. Press OK to confirm the measurement.
2. Aim at the target point and press **DIST**. Press OK to confirm the measurement.

The coordinates of the target point are calculated and displayed.



Press the **PAGE** key to toggle through the available result screens.

Next step

- Press **DONE** to return to the previous screen.
- Or, press **New** to continue measuring with the Angle Offset function.

7.3

Height Transfer

Description

Height transfer is a method for setting up a station. The station is known, a new station height must be computed. Measure to one or more known targets to compute new height for the station. A minimum of two known points and a maximum of 5, can be used to determine the height.

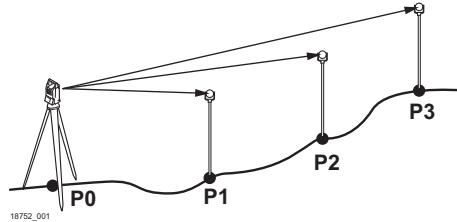

- P0 Instrument station
- P1 Known point
- P2 Known point
- P3 Known point

Access

1. Press **FNC**.
2. Select **Ht. Transfer** from the functions menu.

Height Transfer

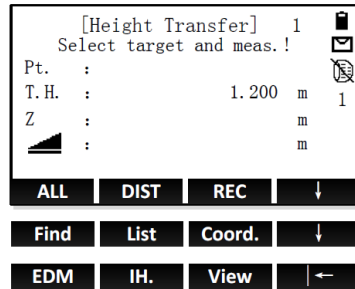

Softkey level 2:

- Find** To search for an entered point.
- List** To display the list of available points.
- Coord.** To enter angle offsets.

Softkey level 3:

- IH.** To set the instrument height.
- View** To display the coordinate and job details of the selected point.

To toggle through the available softkey levels press **F4**.

Field	Description
Pt.	Point ID of the known point

Set the instrument height

1. Press the **F4** key twice to display the third softkey level. Press the softkey **IH.** (F2).
2. Enter the current instrument height.
3. Press **OK** to confirm and return to the Height Transfer screen.

Select a known point

1. Press the **F4** key to display the second softkey level. There are three options to select a known point:

2. Search for a point
 - Enter a point ID.
 - Press **Find** to check if a point with this point ID exists.
 - If there are several points, press the **UP/DOWN** keys to select a point. If no point with this point ID exists, enter or measure the coordinates of the point.
 - Press **OK** to confirm and return to the Height Transfer screen.

View list of points

- Press **List** to display a list of available fixpoints.
- Press the **UP/DOWN** keys to select a point.
- Press **OK** to confirm and return to the Height Transfer screen.

Enter point coordinates manually

- Press **Coord..**
- Enter a point ID and the coordinates of the new fixpoint.
- Press **OK** to confirm and return to the Height Transfer screen.

Measure the known point

1. Aim at the known point.

2. To start measuring and save the measured values, press ALL or DIST+REC.

3. The station height is calculated and displayed in the result screen.

Next step

- To select and measure another known point, press **AddPT.**
- To remeasure the current known point, press **Back.**
- To complete the station setup, press **OK.** Refer to "Complete station setup".

Complete station setup

[Set STA H0]	
Station :	STN
Old H0 :	0.000 m
New H0 :	0.781 m
Δ H0 :	0.781 m
Back OLD AVG NEW	

- Back** To return to Height Transfer screen.
- OLD** To set the station height to the old value.
- AVG** To set the station height to the average of the old and the new value.
- NEW** To set the station height to the new value.

Field	Description
Old H0	Old value of the station height.
New H0	New value of the station height, calculated from the measured known points.
ΔH0	Average of old and new station height.

7.4

Hidden Point

Description

Hidden Point function is used to measure a point that is not directly visible. It is necessary to use a special hidden point rod, of which the length is known.

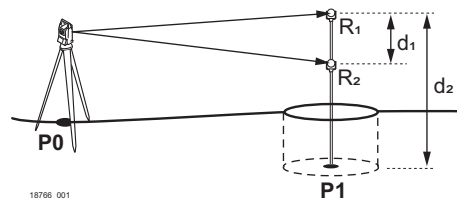

- P0 Instrument station
- P1 Hidden point
- R1 Prism 1
- R2 Prism 2
- d1 Distance between prism 1 and 2
- d2 Rod length

Access

1. Press **FNC**.
2. Press the **PAGE** key to display the second screen.
3. Select **Hidden Point** from the functions menu.

Hidden Point

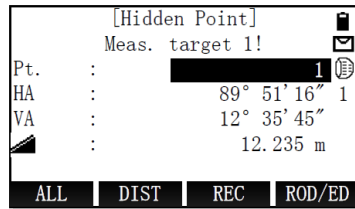

ROD/ED To enter the details of the measuring rod.

1. To enter the details of the measuring rod, press **ROD/ED**.
 - Rod length: Total length of hidden point rod.
 - R1-R2: Spacing between the centres of the prisms R1 and R2.
 - Error Limits: Limit for the difference between the given and measured spacing of the prisms. If the tolerance value is exceeded, a warning is issued.Press **OK** to confirm and return to the Hidden Point screen.
 2. Aim at Prism 1.
To start measuring and save the measured values, press **ALL** or **DIST+REC**.
 3. Aim at Prism 2.
To start measuring and save the measured values, press **ALL** or **DIST+REC**.
-  The hidden point coordinates are calculated and displayed in the result screen. If the tolerance value is exceeded, a warning is issued.
- To accept and continue to the result screen, press **Accept**.
 - To remeasure the prisms, press **New**.

Next step

- To save the results and exit the Hidden Point function, press **Done**.
- To return to the Hidden Point screen, press **New**.

7.5

Coding

Description

Codes contain information about recorded points. With the help of coding, points can be assigned to a particular group simplifying later processing.

Codes are stored in codelists, with each codelist supporting a maximum of 200 codes.

GSI coding

Codes are always stored as free codes (WI41-49), that means that codes are not directly linked to a point. They are stored before the measurement.

A code is always recorded for each measurement as long as the code is displayed in the **Code:** field. For a code not to be recorded, the **Code:** field must be cleared.

Extend codes

To each code a description and a maximum of 8 attributes with up to 9 characters each can be assigned. Existing code attributes are displayed in fields **Text 1** to **Text 8**.

Access

1. Press the **FNC** key from within the active application.
2. Press the **PAGE** key to display screen 2.
3. Select **Free Coding** (6).



OR:

If available within the active application, press the softkey **Code**.

Select a code from code library

	[View Code]	1/5	▼
Code	:	CODEA	◀▶
Note	:		
Info 1	:	AAAAAA	
Info 2	:	BBBBBB	
Info 3	:	CCCCCC	
Info 4	:	DDDDDD	
		Find	New
		REC	OK

- Find** To search for a code.
- New** To enter a new code.
- REC** To add the data of the currently selected code to the job without linking the code to any measured point.
- OK** To apply the selected code and return to the currently active application.

Field	Description
Code	List of existing code names.  At the top right corner, the total number of available codes is displayed.
Note	Additional remarks.
Info 1 to Info 8	More information lines, freely editable. Used to describe attributes of the code.
1.	To select a code from the code library, press the LEFT/RIGHT keys. Use the UP/DOWN keys to view all pages for the selected code
	To search for a specific code name, press Find . To enter a new code, press New . Refer to "10.5 Managing Codes".
2.	To apply the selected code and return to the currently active application, press OK .

8

Applications - Getting Started

8.1

Overview

Description

Applications are predefined programs, that cover a wide spectrum of surveying duties and facilitate daily work in the field. The following applications are available:

- Surveying
- Free Station
- Tie Distance
- Area
- Remote Height
- COGO
- Road

8.2

Starting an App

Access

1. Select **Program** (2) from the Main Menu.
2. To toggle through the available screens, press the **PAGE** key.
3. To select an application in the Program menu, press a function key, **F1 - F4**.

Pre-settings screens

Pre-settings for Surveying is shown as an example. Any additional settings for particular applications are explained within the chapters for those applications.

[Surveying]				
[*]	F1	Set Job	(1)	
[]	F2	Set STA	(2)	
[]	F3	Set B. S.	(3)	
	F4	Start	(4)	
F1		F2	F3	F4

[*] = Setting has been made.
[] = Setting has not been made.
F1-F4 To select menu item.

Field	Description
Set Job	To define the job where data will be saved. Refer to "8.3 Selecting the Job".
Set STA	To define the current position of the instrument station. Refer to "8.4 Selecting the Station".
Set B.S.	To define the orientation and horizontal direction of the instrument station. Refer to "8.5 Selecting the Orientation".
Start	Starts the selected application.

8.3

Selecting the Job

Description

All data is saved in Jobs, like file directories. Jobs contain measurement data of different types, for example measurements, codes, fixpoints or stations. Jobs are individually manageable and can be exported, edited or deleted separately.

Access

1. Select **Program** (2) from the Main Menu.
2. To select an application in the Program menu, press a function key, **F1 - F4**.
3. Select **Set Job** (1) in the pre-settings screen of the application.

```

[New Job]
Job   :  JOB1
Operator:
Note1 :
Note2 :
date  : 20150515
Time  : 14:10:20
Back  [ ] [ ] [ ] [ ]
OK    [ ] [ ] [ ] [ ]

```

- Back** To go back without saving the entered job data.
- OK** To save the entered job data and return to the pre-settings screen. The new job is set as current job.

Recorded data

Once a job is set up, all subsequent recorded data will be stored in this job.

If no job was defined and an application was started and a measurement was recorded, then the system automatically creates a new job and names it "DEFAULT".

8.4

Selecting the Station

Description

All measurements and coordinate computations are referenced to the set station coordinates. The coordinates can be entered manually or selected from the memory.

The station coordinates that are set must include:

- at least grid coordinates (E, N), and
- the station height, if required.

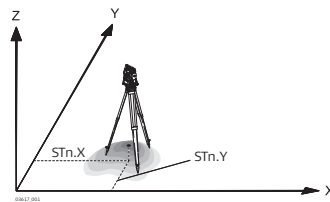

Directions

- X Easting
Y Northing
Z Height

Station coordinates

- Stn.X Easting coordinate of station
Stn.Y Northing coordinate of station

Access

1. Select **Program** (2) from the Main Menu.
2. To select an application in the Program menu, press a function key, **F1 - F4**.
3. Select **Set STA** (2) in the pre-settings screen of the application.

Set station

Set the station coordinates

```

[Set STA]
Input STA PT!
Station :  A1
Find  List  Coord.

```

- Find** To search for an existing point with the entered point ID.
- List** To select a point from the list of existing points.
- Coord.** To enter the point coordinates manually.

There are several options to set the station coordinates:

- To search for an existing point, enter a point ID and press **Find** (refer to "3.6 Pointsearch"). Select a point from the search result list. Press **OK** to confirm.
- To select an existing point, press **List**. Press the **UP/DOWN** keys to select a point from the list. Press **OK** to confirm.
- To enter the coordinates manually, press **Coord.**. Enter point ID and coordinates. Press **OK** to confirm.

Set the instrument height

Once the station coordinates are set, you can enter the instrument height.

[Set STA]
Input I.H!
IH. : 1.400 m
Back OK

Back To set another station point.
OK To confirm and return to the pre-settings screen.



If no station was set and an application was started, or if in **Survey** and a measurement was recorded, then the last station is set as the current station.

Next step

The **Inst.Ht.** field appears once the station coordinates have been entered. Enter the instrument height if desired and press **OK** to return to the **Pre-Settings** screen.

8.5 Selecting the Orientation

8.5.1 Overview

Description

All measurements and coordinate computations are referenced to the orientation of the set station. The orientation can be entered manually or determined from points that are either measured or selected from the memory.

Access

1. Select **Program** (2) from the Main Menu.
2. To select an application in the Program menu, press a function key, **F1 - F4**.
3. Select **Set B. S.** (3) in the pre-settings screen of the application.
 - Select **Angle Setting** to enter a new bearing. Refer to "8.5.2 Manual Orientation".
 - Select **Coordinates** to calculate and set the orientation using existing coordinates. Refer to "8.5.3 Orientation with Coordinates".

8.5.2 Manual Orientation

Manual angle setting

[Angle Setting]
Azimuth : 50 ° 00' 00"
T.H. : 1.500 m
BS PT : DEFAULT1
Aim BS. Then ALL/REC!
ALL REC Zero EDM

EDM To change the EDM settings.

Field	Description
Azimuth	Horizontal direction of the station
T.H.	Reflector height
BS PT	Point ID of the backsight point

Step by step

1. Aim at the backsight point.
2. Set the orientation by one of the following options:
 - Manually enter the azimuth, reflector height and name of the backsight point. Press **REC**.
Orientation is set and pre-Settings screen is displayed.
 - To set the azimuth to 0, press **Zero**. Press **REC**.
Orientation is set and pre-Settings screen is displayed.
 - To measure and set the azimuth, press **ALL**.
Orientation is set and pre-settings screen is displayed.

8.5.3

Orientation with Coordinates

Orientation with coordinates

Set the backsight point coordinates

[Set BS]

Input BS PT!

BS PT : DEFAULT1

Find
List
Coord.

- Find** To search for an existing point with the entered point ID.
- List** To select a point from the list of existing points.
- Coord.** To enter the point coordinates manually.



Field	Description
BS PT	Point ID of the backsight point

There are several options to set the coordinates of the backsight point:

- To search for an existing point, enter a point ID and press **Find** (refer to "3.6 Pointsearch"). Select a point from the search result list. Press **OK** to confirm.
- To select an existing point, press **List**. Press the **UP/DOWN** keys to select a point from the list. Press **OK** to confirm.
- To enter the coordinates manually, press **Coord..** Enter point ID and coordinates. Press **OK** to confirm.

Measure the backsight point

Once the coordinates are set, the "Meas. BS" screen is displayed.

Meas. BS	
BS PT :	DEFAULT1
T. H. :	1.500 m
HA :	45° 00' 00"
Azimuth :	45° 00' 00"
 :	10.000 m
 :	1.726 m

ALL **DIST** **REC** **EDM**

EDM To change the EDM settings.

1. Aim at the backsight point and press the **ENT** key.
2. Set the azimuth by one of the following options:
 - To measure and check the azimuth, press **DIST**.
To toggle through the available result screens, press the **PAGE** key.
To set the measured azimuth, press **REC**.
Orientation is set and pre-Settings screen is displayed.
 - To measure and set the azimuth, press **ALL**.
Orientation is set and pre-Settings screen is displayed.



If no orientation is set and an application is started, the current horizontal direction is set as the orientation.

Next step

Select **Start** to open the application.

9

Application

9.1







Input and Result Fields

Description of fields

The following table describes the input and result fields that are found within the firmware applications. These fields are described here once and not repeated in the application chapters.

Field	Description	Application
Area	Calculated result of polygonal area between the already measured points. Displayed as soon as 3 points are measured.	Area
AZ	Direction from known point to new point.	COGO
AZ1 / AZ2	Direction from first/second known point to new point.	COGO
Base Pt.	Point ID of the base point	COGO
Code	Code name	Commonly used
CtrPt	Point ID of centre point	Reference Arc
Cum. Length	Cumulation of the segment lengths. Changes with the current number of segments. Includes the misclosure segment length if applicable.	Reference Line
E	Easting coordinate of the point.	Commonly used
e (Y/E)	Error limit for Easting coordinate.	Resection
e (Y/N)	Error limit for Northing coordinate.	Commonly used
e (Z/H)	Error limit for Height coordinate.	Commonly used
EndPt	Point ID of end point	Reference Arc
EndW. OS	Longitudinal distance	COGO
	Longitudinal offset: Positive if stakeout point is further away from the reference line.	Reference Line
From / To	Point ID of the first/second known point.	COGO - Inverse
HA	Horizontal angle to the point.	Q-Survey
HD	Horizontal distance from known point to new point.	COGO - Traverse
	Extension distance.	COGO - Extension
HD1 / HD2	Radius of circle around the first/second known point.	COGO - Extension
Height	Height offset of the reference line to the selected reference height. Positive values are higher than the selected reference height.	Reference Line
ΔHZ	Angle offset: Positive if stakeout point is to the right of the measured point. (→) Negative if stakeout point is to the left of the measured point. (←)	Commonly used
I.H.	Instrument height	Commonly used
Increment	Length of incrementation.	Reference Line
Length	Length of the baseline	Reference Line
ΔLength	Longitudinal offset: Positive if stakeout point is closer to the station than the measured point.(↓) Negative if stakeout point is further away than the measured point. (↑)	Commonly used
	Calculated distance longitudinal to the reference line.	Reference Line

Field	Description	Application
Line	Longitudinal offset of the first reference point (P3) of the reference line in the direction of the second base point (P2). Positive values are toward the second base point	Reference Line
Δ Line	Calculated distance from start point along the reference arc. Negative if stakeout point is beyond the end point.	Reference Arc
Line Length	Calculated length of the defined reference line.	Reference Line
Misclosure	Any remaining line length after segment length has been entered.	Reference Line
N	Northing coordinate of the point.	Commonly used
Offset	Parallel offset of the reference line relative to the baseline (P1-P2). Positive values are to the right of the baseline.	Reference Line
Δ Offset	Calculated distance from the reference arc to the stakeout point along the radius. Positive if the stakeout point is within the arc. Negative if stakeout point is outside the arc.	Reference Arc
Perimeter	Perimeter of the polygonal area.	Area
Pt., Pt	Point ID of stakeout point.	Commonly used
PT1, Pt 1	<ul style="list-style-type: none"> Point ID of the first known point. Point ID of the start point. 	COGO
	Point ID of first base point.	Stakeout
	Name of first reference point.	Reference Line
PT2	<ul style="list-style-type: none"> Point ID of the second known point. Point ID of the end point. 	COGO
	Name of second reference point	Reference Line
PT3	<ul style="list-style-type: none"> Point ID of the third known point. Point ID of the offset point. 	COGO
PT4	Point ID of the fourth known point.	COGO
PT Count	Number of already measured target points.	Area
Rotate	Rotation of the reference line clockwise around the reference point (P3).	Reference Line
Search	Value for Point ID search. After entry, the firmware searches for matching points. If a matching point does not exist, the screen "Find Point In Job" is displayed.	Commonly used
Segment Length	Length of each segment. Updated automatically if the number of segments is entered.	Reference Line
Segment No.	<ul style="list-style-type: none"> Number of segments. Updated automatically when editing the segment length. Number of currently selected segment. 	Reference Line
Slope	Slope between point 1 and point 2.	Tie Distance
Start	Point ID of start point.	Reference Arc
Start Chain	Distance from the reference line start point to the beginning grid start point.	Reference Line
T.H.	Target height	Commonly used
	 If you change the EDM setting "Reflector" from prism to non-prism, the instrument keeps the target height. If necessary, change the target height.	
Transverse	Offset distance	COGO
	Offset distance from the reference line.	Stakeout

Field	Description	Application
	Perpendicular offset: Positive if stakeout point is to the right of the reference line.	Reference Line
$\Delta Trav.$	Perpendicular offset: Positive if stakeout point is to the left of the measured point. (\leftarrow) Negative if stakeout point is to the right of the measured point. (\rightarrow)	Stakeout
	Calculated distance perpendicular from the reference line.	Reference Line
VA	Vertical angle to the point.	Commonly used
VD	Height to the point.	Commonly used
$\Delta Y/E$	Easting offset: Positive if stakeout point is to the right of the measured point. Negative if stakeout point is to the left of the measured point.	Stakeout
$\Delta Y/N$	Northing offset: Positive if stakeout point is further away from the station than the measured point. Negative if stakeout point is closer to the station than the measured point.	Stakeout
$\Delta Z/H$	Height offset: Positive if stakeout point is lower than the measured point. (\downarrow) Negative if stakeout point is higher than the measured point. (\uparrow)	Stakeout
Z	Height coordinate of the point.	Commonly used
	Height offset: Positive if stakeout point is higher than the reference line.	Reference Line
	<ul style="list-style-type: none"> Horizontal distance to first base point Horizontal distance to centre or start point Horizontal distance to start or end point 	Commonly used
Δ 	Horizontal distance between point 1 and point 2.	Tie Distance
Δ 	Horizontal offset: Positive if stakeout point is further away from the station than the measured point. (\downarrow) Negative if stakeout point is closer to the station than the measured point. (\uparrow)	Stakeout Road Stakeout
Δ 	Slope distance between point 1 and point 2.	Tie Distance
	Height of first base point	Reference Line
	<ul style="list-style-type: none"> Height to the centre or start point Height to the start or end point 	Reference Arc
Δ 	Height offset: Positive if stakeout point is lower than the measured point. (\downarrow) Negative if stakeout point is higher than the measured point. (\uparrow)	Stakeout Road Stakeout
Δ 	Height difference between point 1 and point 2.	Tie Distance
	Calculated height difference relative to the defined reference height.	Reference Line
	Calculated height difference relative to the start point of the arc. Positive if stakeout point is higher than the start point.	Reference Arc

9.2

Surveying

Description

Surveying is an application used for the measurement of an unlimited number of points. It is comparable to **Q-Survey** from the start screen, but data is recorded and it includes pre-settings for the job, station and orientation prior to beginning a survey.

Access

1. Select **Program** (2) from the Main Menu.
2. Select **Surveying** (1) from the Program menu.
3. Complete application pre-settings. Refer to "8 Applications - Getting Started".
4. Select **Start** to open the application.

Surveying

The screenshot shows the Surveying application interface. At the top, it displays "[Surveying] 1/3". Below this, there are several fields for data entry: Pt. (Point ID) with a value of 1, T.H. (Reflector Height) with a value of 1.500 m, Code (1), HA (Horizontal Angle) with a value of 13° 29' 59", and VA (Vertical Angle) with a value of 90° 59' 23". At the bottom of the screen, there are two rows of softkeys. The first row contains ALL, DIST, REC, and a downward arrow. The second row contains ALL, Code, EDM, and a downward arrow. The third row contains ALL, IndivPt, Data, and a leftward arrow.

Softkey level 3

IndivPt To switch between individual and consecutive point ID.

Data To view measurement data. Refer to "10.4 Managing Measurement Data".

1. Enter a point ID and the reflector height.
2. Aim at the target point.
To start measuring and save the measured values, press **ALL** or **DIST+REC**.
After a measurement the instrument automatically increments the point ID.
3. Repeat the previous step to measure another point.
 To measure a special point with an individual point ID, press **F4** twice and select **IndivPt**. Measure the individual point.
To all following points, the previously defined point ID and its incrementation are applied.
4. To exit the application, press **ESC**.

9.3

Stakeout

Description

Stakeout is an application used to place marks in the field at predetermined points. These predetermined points are the points to be staked. The points to be staked may already exist in a job on the instrument, or be manually entered.

The application can continuously display differences between current position and desired stakeout position.

Stakeout modes

Points can be staked using different modes: Polar mode, Orthogonal to station mode and Cartesian mode.

Polar Stakeout mode

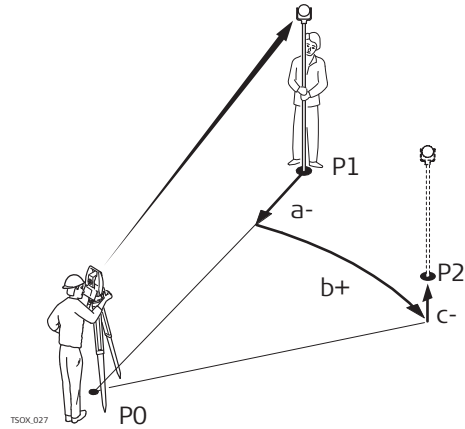

- P0 Instrument station
- P1 Current position
- P2 Point to be staked
- a- Δ \nearrow : Difference in horizontal distance
- b+ Δ \searrow : Difference in direction
- c+ Δ \uparrow : Difference in height

Orthogonal to Station Stakeout mode

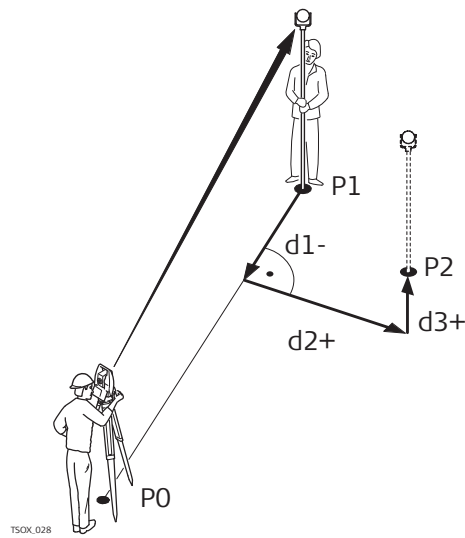

- P0 Instrument station
- P1 Current position
- P2 Point to be staked
- d1- Δ Length: Difference in longitudinal distance
- d2+ Δ Trav.: Difference in perpendicular distance
- d3+ Δ Z/H: Difference in height

Cartesian Stakeout mode

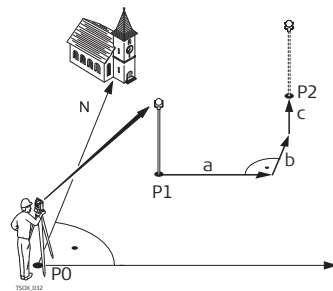

- P0 Instrument station
- P1 Current position
- P2 Point to be staked
- a Δ Y/E: Difference in Easting coordinate
- b Δ Y/N: Difference in Northing coordinate
- c Δ Z/H: Difference in height

Access

1. Select **Program** (2) from the Main Menu.
2. Select **Stakeout** (2) from the Program menu.
3. Complete application pre-settings. Refer to "8 Applications - Getting Started".
4. Select **Start** to open the application.

Stakeout screens

Polar Stakeout mode (page 1/3):

[Stakeout] 1/3			
Search :	[REDACTED] *		
Pt. :	5		
T.H. :	1.500 m		
△Hz :	-13° 29' 60"		
△	---		
△	---		
ALL	DIST	REC	↓
EDM	Coord.	View	↓
Polar	SO-PT		←

Softkey level 2

Coord. To enter coordinates manually and save the stakeout point to the current job.

Softkey level 3

Polar To define a stakeout point with polar coordinates.

SO-PT To enter coordinates manually without saving the stakeout point.

Orthogonal to Station Stakeout mode (page 2/3):

[Stakeout] 2/3			
Search :	[REDACTED] *		
Pt. :	6		
T.H. :	1.800 m		
△Length: *	0.000 m		
△Trav. :	2.052 m		
△Z/H :	-1.320 m		
ALL	DIST	REC	↓

Cartesian Stakeout mode (page 3/3):

[Stakeout] 3/3			
Search :	[REDACTED] *		
Pt. :	5		
T.H. :	2.000 m		
△Y/E :	-0.306 m		
△X/N :	0.404 m		
△Z/H :	-1.299 m		
ALL	DIST	REC	↓

Stakeout step-by-step

Setting the stakeout point coordinates

There are several options to set the coordinates of the stakeout point:

- To search for an existing point, enter a point ID and press **ENT**.
- To enter coordinates manually and save the stakeout point to the current job, press **F4** and **Coord.**
- To enter coordinates manually without saving the stakeout point, press **F4** twice and then **SO-PT**. The point ID is set to "DEFAULT".

Once the coordinates are set, you can start with staking out.

9.4

Resection

Description

Resection is an application used to determine the instruments position from measurements to known points. A minimum of 2 known points and a maximum of 10, can be used to determine the position.

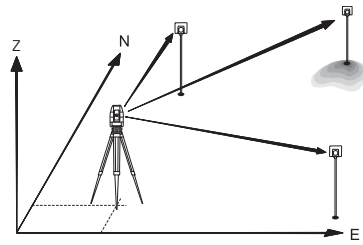

Access

1. Select **Program** (2) from the Main Menu.
2. Select **Resection** (3) from the Program menu.
3. Complete application pre-settings.
Set Job: refer to "8.3 Selecting the Job".
Set Error Limits: refer to "Set error limits".
4. Select **Start** to open the application.

Set error limits

[Set Error Limits]	
Input error limits!	
Status :	On $\leftarrow \rightarrow$
e(Y/E) :	0.010 m
e(X/N) :	0.010 m
e(Z/H) :	0.010 m
OK	

Status To activate or deactivate the error limits, press the LEFT/RIGHT keys.

OK To save settings and return to pre-settings screen.

Enter data for station and target point

1. Enter the name of the station and the height of the instrument in the **Resection-Station** screen and press **OK**.
2. Set the first target point in the **ResectionTarget PT** screen.
 - To select a point from the memory, press **Find** or **List**.
 - To enter the point coordinates manually, press **F4** and **Coord..**
Enter the reflector height.

Measure target points

[Resection-Observe]	
Pt. :	1 $\leftarrow \rightarrow$
T. H. :	1.500 m $\leftarrow \rightarrow$
HA :	177° 55' 56" 1
VA :	89° 15' 12"
\blacktriangleleft :	16.132 m
ALL NEXT PT Result \downarrow	

NEXT PT To set another target point.

Result Displayed once the minimum number of measured target points is reached. Press to calculate the station position.

Next step

To calculate and display the station position data, press **Result**.

Result screen

[Station Coordinate]	
Station :	DEFAULT
IH. :	1.000 m
Y0/E0 :	-7.422 m
X0/N0 :	10.628 m
Z0/H0 :	1.464 m
<div style="display: flex; justify-content: space-around;"> Back Errors OK </div>	

Errors To display the standard deviation.

Step-by-step

1.
 - To measure another target point, press **Back**.
 - To display the standard deviation, press **Errors**.

2. To set the station and exit the application, press **OK**.

9.5

Tie Distance

Description

Tie Distance is an application used to compute slope distance, horizontal distance, height difference and azimuth of two target points which are either measured, selected from the memory, or entered using the keypad.

The user can choose between two different methods:

- **Polygonal:** P1-P2, P2-P3, P3-P4.
- **Radial:** P1-P2, P1-P3, P1-P4.

Polygonal method

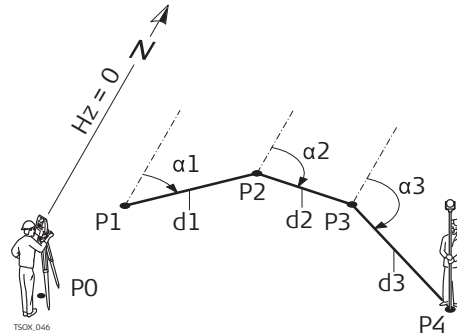

- P0 Instrument station
- P1-P4 Target points
- d1 Distance from P1-P2
- d2 Distance from P2-P3
- d3 Distance from P3-P4
- α_1 Azimuth from P1-P2
- α_2 Azimuth from P2-P3
- α_3 Azimuth from P3-P4

Radial method

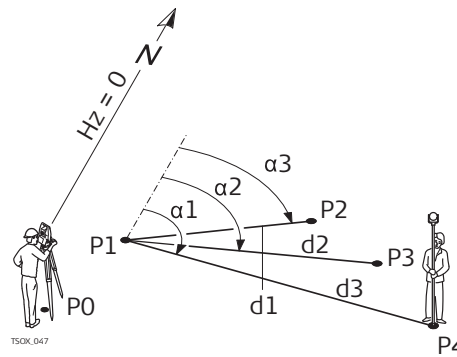

- P0 Instrument station
- P1-P4 Target points
- d1 Distance from P1-P2
- d2 Distance from P1-P3
- d3 Distance from P1-P4
- α_1 Azimuth from P1-P4
- α_2 Azimuth from P1-P3
- α_3 Azimuth from P1-P2

Access

1. Select **Program** (2) from the Main Menu.
2. Select **Tie Distance** (4) from the Program menu.
3. Complete application pre-settings. Refer to "8 Applications - Getting Started".
4. Select **Start** to open the application.
5. Select **Polygonal** (1) or **Radial** (2).

Polygonal method

Measure target points

1. Aim at the first target point.
To start measuring and save the measured values, press **ALL** or **DIST+REC**.
After measurement, the field PT2 is displayed.



Alternatively, select a target point from memory or enter the point coordinates manually.
Use either **Find**, **List** or **Coord..**

2. Aim at the second target point.
To start measuring and save the measured values, press **ALL** or **DIST+REC**.
After measurement, the result screen is displayed.

Result screen

PT1	:	1	
PT2	:	2	
Slope	:	2.9%	
	:	+1.232m	
	:	-0.562m	
	:	+0.362m	
Azimuth	:	12° 27' 13"	
NewPt1		NewPt2	Radial

NewPt1 To calculate an extra line. The program starts again at point 1.

NewPt2 To set point 2 as the starting point of a new line. A new point 2 must be measured.

Radial To switch to radial method.

Radial method

Measure target points

1. Aim at the first target point.
To start measuring and save the measured values, press **ALL** or **DIST+REC**.
After measurement, the field PT2 is displayed.



Alternatively, select a target point from memory or enter the point coordinates manually.
Use either **Find**, **List** or **Coord..**

2. Aim at the second target point.
To start measuring and save the measured values, press **ALL** or **DIST+REC**.
After measurement, the result screen is displayed.

Result screen

PT1	:	1	
PT2	:	2	
Slope	:	2.9%	
	:	+1.232m	
	:	-0.562m	
	:	+0.362m	
Azimuth	:	12° 27' 13"	
NewPt1		NewPt2	Polygonal

NewPt1 To calculate an extra line. The program starts again at point 1.

NewPt2 To set point 2 as the starting point of a new line. A new point 2 must be measured.

Polygonal To switch to polygonal method.

9.6

Area

Description

Area is an application used to calculate polygonal areas to a maximum of 20 points connected by straights. The target points have to be measured, selected from memory, or entered manually in a clockwise direction. The calculated area is projected onto the horizontal plane (2D).

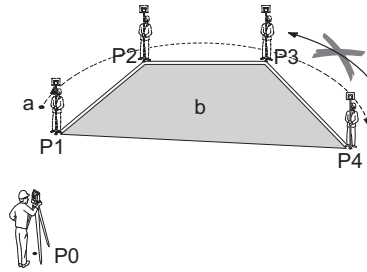

- P0 Instrument station
- P1 Start point
- P2-4 Target points
- a Perimeter, polygonal length from start point to the current measured point.
- b Calculated area always closed to the start point P1, projected onto the horizontal plane.

Access

1. Select **Program** (2) from the Main Menu.
2. Press the **PAGE** key to display screen 2. Select **Area** (5) from the Program menu.
3. Complete application pre-settings. Refer to "8 Applications - Getting Started".
4. Select **Start** to open the application.

Measure target points

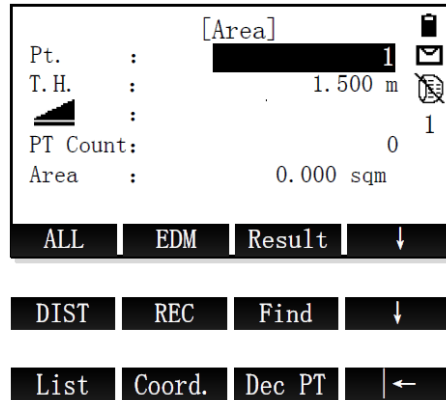

Result To display the result screen.
Dec PT To delete the last measured target point.

1. Enter a point ID. Aim at the first target point.
 To start measuring and save the measured values, press **ALL** or **DIST+REC**.
 Alternatively, select a target point from memory or enter the point coordinates manually.
 Use either **Find**, **List** or **Coord..**
2. Measure as many additional target points as desired, at minimum 3 points.

Next step

To display the area result screen, press **Result**.

Result screen

[Area Result]	
PT Count:	3
Area :	12.362 m ²
Area :	0.001 ha
Area :	144.125 f ²
Perimeter:	15.654 m

New Area | Graph | Add PT

- New** To define a new area.
- Area**
- Graph** To display the area graph.
- Add PT** To add a new target point to the existing area.



Perimeter are updated if further area points are added.

9.7

Remote Height

Description

Remote Height is an application used to compute points directly above the base prism without a prism at the target point.

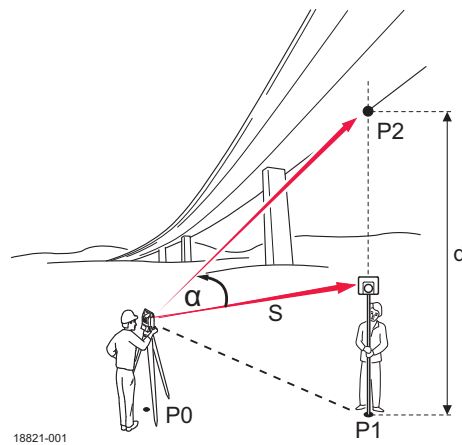

- P0 Instrument station
- P1 Base point
- P2 Remote point
- d Height difference from P1 to P2
- S Slope distance
- α Vertical angle between base point and remote point

Access

1. Select **Program** (2) from the Main Menu.
2. Press the **PAGE** key to display screen 2. Select **Remote Height** (6) from the Program menu.
3. Complete application pre-settings. Refer to "8 Applications - Getting Started".
4. Select **Start** to open the application.

Remote height measurement

1. Move the reflector directly beneath the remote point.
2. Aim at the reflector.
3. **Base Pt. screen**
Enter the reflector height.
To start measuring and save the measured values, press **ALL** or **DIST+REC**.

[Base Pt.]	
Aim and meas. base PT!	
Base Pt. :	1
T. H. :	1.500 m
▴ :	4.082 m
ALL DIST REC ↓	
EDM H. T. ? ←	



- To determine an unknown reflector height, press **F4** and then **H. T.?**
- Aim at the bottom of the reflector rod.
 - To start measuring and save the measured values, press **ALL** or **DIST+REC**.
 - Aim at the reflector.
 - To determine the reflector height, press **OK**.

4. The screen "REM PT" is displayed.

5. Turn the telescope and aim at the remote point.
To measure the remote point, press **OK**.

Next step

- To enter and measure a new base point, press **Base Pt.**
- To exit the application, press **ESC**.

9.8

COGO

9.8.1

Starting

Description

COGO is an application used to perform coordinate geometry calculations such as, coordinates of points, bearings between points and distances between points. The COGO calculation methods are:

- Inverse and Traverse
- Intersections
- Offset
- Extension

Access

1. Select **Program** (2) from the Main Menu.
2. Press the **PAGE** key to display screen 2. Select **COGO** (7) from the Program menu.
3. Complete application pre-settings. Refer to "8 Applications - Getting Started".
4. To display the COGO menu, select **Start**.

9.8.2

COGO Calculation - Inverse Method

Access

1. Select **Traverse&Inverse** (1) from the COGO menu.
2. Select **Inverse** (1).

Description

Use the Inverse subapplication to calculate the distance, direction, height difference and grade between two known points.

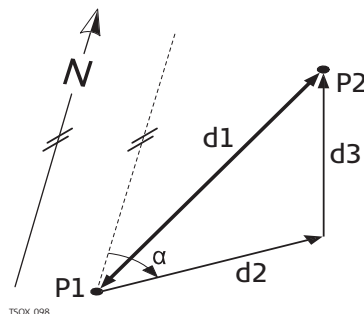

Known

- P1 First known point
- P2 Second known point

Unknown

- α Direction from P1 to P2
- d1 Slope distance between P1 and P2
- d2 Horizontal distance between P1 and P2
- d3 Height difference between P1 and P2

Inverse

[Inverse]
Input data!

From : PT6

To :

Meas. | Result | Find | ↓

List | Coord. | ←

Meas. To measure the known point.
Result To calculate and display the result.

Step-by-Step

1. Set the two known points.
2. To calculate and display the Inverse result, press **Result**.
3. To save the result, press **REC**.

9.8.3

COGO Calculation - Traverse Method

Access

1. Select **Traverse&Inverse** (1) from the COGO menu.
2. Select **Traverse** (2).

Description

Use the Traverse subapplication to calculate the position of a new point using the bearing and the distance from a known point. Offset optional.

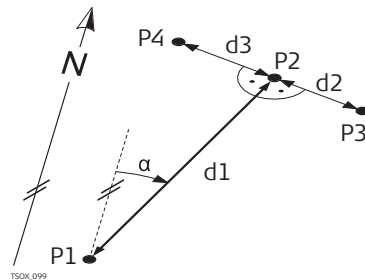

Known
P1 Known point
 α Direction from P1 to P2
d1 Distance between P1 and P2
d2 Positive offset to the right
d3 Negative offset to the left

Unknown
P2 COGO point without offset
P3 COGO point with positive offset
P4 COGO point with negative offset

Traverse

[Traverse]

Pt. : 8

AZ : 15° 34' 20"

HD : 10.536 m

Transverse: 8.361 m

Meas. | Result | Find | ↓

List | Coord. | ←

Meas. To measure the known point.
Result To calculate and display the result.

Step-by-Step

1. Set the known point. There are several options to set a known point:
 - To measure the known point, enter a point ID and press **Meas.**. Enter the reflector height. To start measuring and save the measured values, press **ALL** or **DIST+REC**.
 - To search for an existing point, enter a point ID and press **Find** (refer to "3.6 Pointsearch").
 - To select an existing point, press **List**.
 - To enter the coordinates manually, press **Coord.**

2. Enter direction and horizontal distance to the new point. If necessary, enter an offset distance.

3. To calculate and display the Traverse result, press **Result**.

4. To save the new point, enter a point ID and press **REC**.

9.8.4

COGO Calculation - Intersections

Access

1. Select **Intersection** (2) from the COGO menu.
2. Select an intersection method:
 - **BRG-BRG** (1). Refer to "Bearing - Bearing".
 - **BRG-DST** (2). Refer to "Bearing - Distance".
 - **DST-DST** (3). Refer to "Distance - Distance".
 - **LNLN** (4). Refer to "Line - Line".

Bearing - Bearing

Use the BRG-BRG subapplication to calculate the intersection point of two lines. A line is defined by a point and a direction.

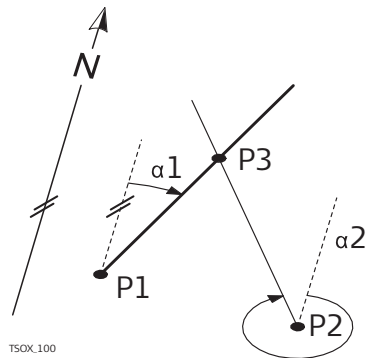

- Known**
- P1 First known point
 - P2 Second known point
 - $\alpha 1$ Direction from P1 to P3
 - $\alpha 2$ Direction from P2 to P3
- Unknown**
- P3 COGO point

[BRG-BRG]	
Input data!	
PT1 :	8
AZ1 :	0° 0' 0"
PT2 :	9
AZ2 :	0° 0' 0"
Meas.	Result
Find	↓

- Meas.** To measure the known point.
Result To calculate and display the result.

Step-by-Step

1. Set the first known point.

2. Enter the bearing of the first known point.

3. Set the second known point.
4. Enter the bearing of the second known point.
5. To calculate the intersection point and display the result, press **Result**.
6. To save the new point, enter a point ID and press **REC**.

Bearing - Distance

Use the BRG-DST subapplication to calculate the intersection point of a line and a circle. The line is defined by a point and a direction. The circle is defined by the centre point and the radius. As a result, there may be none, one or two intersection points.

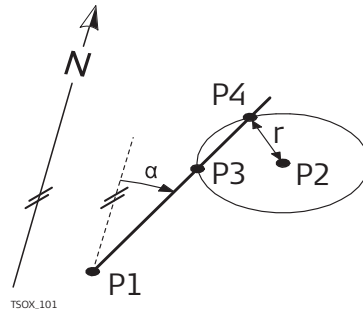

- Known**
- P1 First known point
 - P2 Second known point
 - α Direction from P1 to P3 and P4
 - r Radius, as the distance from P2 to P4 or P3
- Unknown**
- P3 First COGO point
 - P4 Second COGO point

[BRG-DST]	
Input data!	
PT1 :	8
AZ1 :	0° 0' 0"
PT2 :	9
HD2 :	0.000 m
<div style="display: flex; justify-content: space-between; border-top: 1px solid black;"> Meas. Result Find ↓ </div>	

- Meas.** To measure the known point.
Result To calculate and display the result.

Step-by-Step

1. Set the first known point.
2. Enter the bearing of the first known point.
3. Set the second known point.
4. Enter the radius of the circle around the second known point.
5. To calculate the intersection points and display the result, press **Result**.
6.
 - To toggle between the results of first and second intersection point, press **PT1** or **PT2**.
 - To save an intersection point, enter a point ID and press **REC**.

Distance - Distance

Use the DST-DST subapplication to calculate the intersection point of two circles. The circles are defined by the known point as the centre point and the distance from the known point to the COGO point as the radius. As a result, there may be none, one or two intersection points.

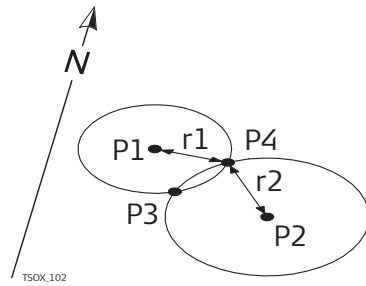

- Known**
 P1 First known point
 P2 Second known point
 r1 Radius, as the distance from P1 to P3 or P4
 r2 Radius, as the distance from P2 to P3 or P4
- Unknown**
 P3 First COGO point
 P4 Second COGO point

[DST-DST]	
Input data!	
PT1 :	8
HD1 :	0.000 m
PT2 :	9
HD2 :	0.000 m
Meas.	Result Find ↓

Meas. To measure the known point.
Result To calculate and display the result.

Step-by-Step

1. Set the first known point.
2. Enter the radius of the circle around the first known point.
3. Set the second known point.
4. Enter the radius of the circle around the second known point.
5. To calculate the intersection points and display the result, press **Result**.
6.
 - To toggle between the results of first and second intersection point, press **PT1** or **PT2**.
 - To save an intersection point, enter a point ID and press **REC**.

Line - Line

Use the LNLN subapplication to calculate the intersection point of two lines. A line is defined by two points.

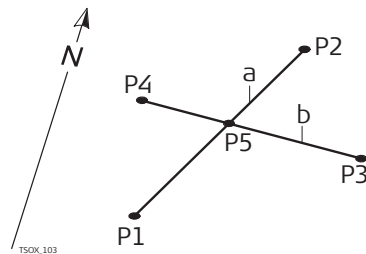

- Known**
 P1 First known point
 P2 Second known point
 P3 Third known point
 P4 Fourth known point
 a Line from P1 to P2
 b Line from P3 to P4
- Unknown**
 P5 COGO point

```

[LNLN]
Input data!
PT1 : 
PT2 : 10
PT3 : 9
PT4 : 5
Meas. | Result | Find | ↓

```

Meas. To measure the known point.
Result To calculate and display the result.

Step-by-Step

1. Set all known points.
2. To calculate the intersection point and display the result, press **Result**.
3. To save the intersection point, enter a point ID and press **REC**.

9.8.5

COGO Calculation - Offsets

Access

1. Select **Offsets** (3) from the COGO menu.
2. Select an offset method:
 - **DistOff** (1). Refer to "Distance offset".
 - **Set Pt** (2). Refer to "Set Point".

Distance offset

Use the DistOff subapplication to calculate the distance and offset of a known point, with the basepoint in relation to a line.

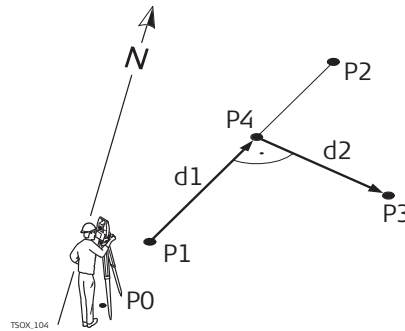

- Known**
- P0 Instrument station
 - P1 Start point of baseline
 - P2 End point of baseline
 - P3 Offset point
- Unknown**
- d1 Δ Line
 - d2 Δ Offset
 - P4 COGO (base) point

```

[Get Foot PT]
Define baseline!
PT1 : 
PT2 : 9
Input Offset PT!
PT3 : 10
Meas. | Result | Find | ↓

```

Meas. To measure the known point.
Result To calculate and display the result.

Step-by-Step

1. Set the start and end point of the baseline as well as the offset point.
2. To calculate the base point and display the result, press **Result**.
3. To save the base point, enter a point ID and press **REC**.

Set Point

Use the Set Pt subapplication to calculate the coordinates of a new point in relation to a baseline from known longitudinal and offset distances.

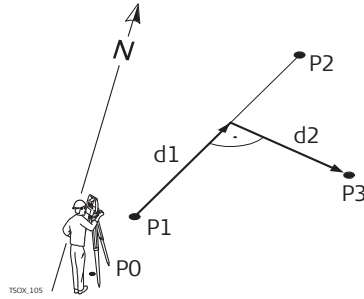

Known	
P0	Instrument station
P1	Start point of baseline
P2	End point of baseline
d1	Δ Line
d2	Δ Offset
Unknown	
P3	COGO point

```
[Get Side PT]
Define baseline!
PT1 : 8
PT2 : 9
Input Length&Trav. !
EndW. OS. : 0.000 m
Transverse: 0.000 m
Meas. | Result | Find | ↓
```

Meas. To measure the known point.
Result To calculate and display the result.

Step-by-Step

1. Set the start and end point of the baseline.
Enter the longitudinal and offset distances.
2. To calculate the offset point and display the result, press **Result**.
3. To save the offset point, enter a point ID and press **REC**.

9.8.6

COGO Calculation - Extension Method

Access

Select **Extension** (4) from the COGO menu.

Description

Use the Extension subapplication to calculate the extended point from a known base line.

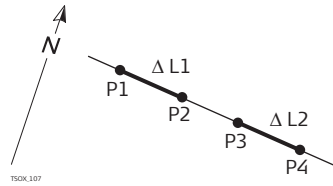

Known	
P1	Start point of baseline
P2	End point of baseline
P3	Base point for extension
$\Delta L1$	Distance P1 to P2
$\Delta L1, \Delta L2$	Extension distance P3 to P4
Unknown	
P4	Extended COGO points

Extension

```
[Extension]
Define line!
PT1 : 8
PT2 : 9
Select & Input!
Base Pt. : 8
HD : 0.000 m
Meas. | Result | Find | ↓
```

Meas. To measure the known point.
Result To calculate and display the result.

Step-by-Step

1. Set the start and end point of the baseline as well as the base point for the extension. There are several options to set a known point:
Enter the extension distance.
2. To calculate the extension point and display the result, press **Result**.
3. To save the extension point, enter a point ID and press **REC**.

9.9

Road

9.9.1

Overview

Access

1. Select **Program** (2) from the Main Menu.
2. Press the **PAGE** key to display screen 2. Select **Road** (8) from the Program menu.
3. Complete application pre-settings. Refer to "8 Applications - Getting Started".
4. To display the Road menu, select **Start**.
5. Road menu:
 - To manage road files, select **Road Manage**. Refer to "9.9.2 Road Manage".
 - To define the horizontal curve, select **HC list**. Refer to "9.9.3 Horizontal Curve Definition".
 - To define the vertical curve, select **Vert. curve list**. Refer to "9.9.4 Vertical Curve Definition".
 - To stake out the defined road data, select **Road Stakeout**. Refer to "9.9.5 Road Stakeout".

9.9.2

Road Manage

Access

Select **Road Manage** (1) from the Road menu.

Manage road files

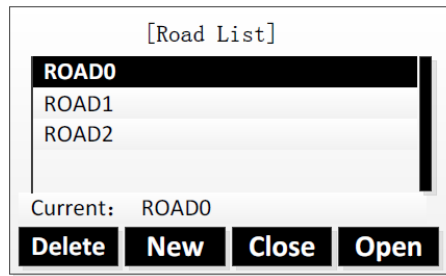

- Delete** To delete selected road file.
- New** To create a road.
- Close** To close currently open road file.
- Open** To open selected road file.

Field	Description
Current	Displays name of the currently used/open road file.

To delete the currently used road file, you need to close it first.

9.9.3 Horizontal Curve Definition

Description

There are two ways of defining a horizontal curve:

- Elements method
- Intersection method

Elements method

A horizontal curve can consist of 30 elements at maximum. The following elements can be defined:

Element	Description
Startpoint	The startpoint has to be defined before any other element by <ul style="list-style-type: none"> • Chainage position • Easting and Northing coordinates
Straight line	A straight has to be defined by: <ul style="list-style-type: none"> • Azimuth • Distance (not negative!)
Circular curve	A circular curve has to be defined by: <ul style="list-style-type: none"> • Radius: <ul style="list-style-type: none"> If the radius is positive, the arc bends in clockwise direction along the line. If the radius is negative, the arc bends in anticlockwise direction along the line. • Arc length: <ul style="list-style-type: none"> The value should not be negative.

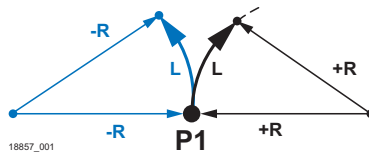

- P1 Start point
- R Negative radius for anti-clockwise direction
- +R Positive radius for clockwise direction
- L Arc length

Transition curve	A transition curve has to be defined by: <ul style="list-style-type: none"> • Minimum radius: <ul style="list-style-type: none"> If the radius is positive, the arc bends in clockwise direction along the line. If the radius is negative, the arc bends in anticlockwise direction along the line. • Arc length: <ul style="list-style-type: none"> The value should not be negative.
------------------	--

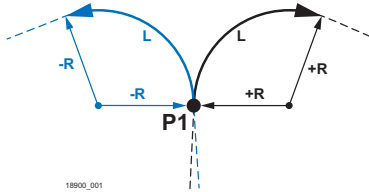
Element	Description
	<p>P1 Start point</p> <p>-R Negative radius for anti-clockwise direction</p> <p>+R Positive radius for clockwise direction</p> <p>L Arc length</p>

Intersection method

A horizontal curve can also be defined by entering the intersection point of the curve tangents, the curve radius and the two parameters A1 and A2.

The values for radius, A1 and A2 should not be negative.

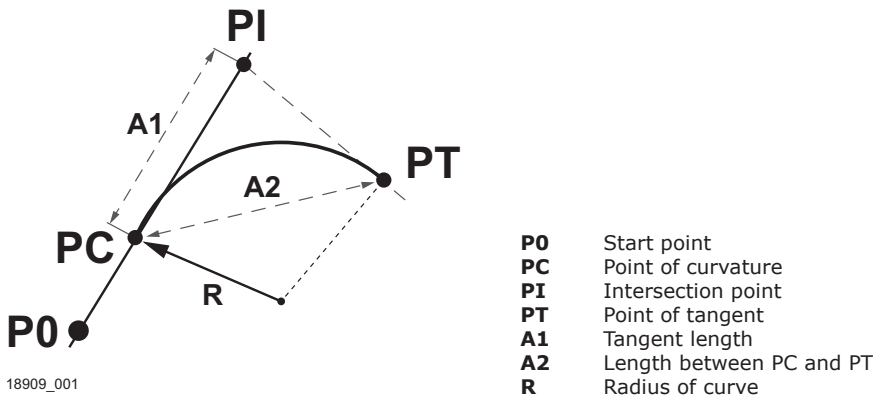

Access

Select **HC list** (2) from the Road menu.

Define a horizontal curve

"HC list" screen

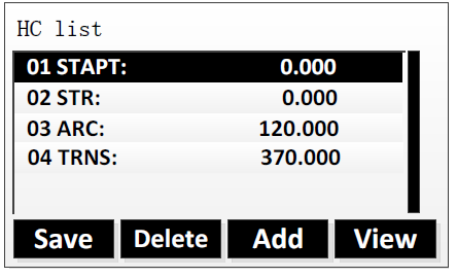

- Save** To save the entered road data.
- Delete** To delete the selected road element.
- Add** To add a road element.
- View** To view details of the selected road element.

Horizon Curve	
Chain :	0.000 m
Azimuth :	0°00' 00"
<div style="display: flex; justify-content: space-around; margin-top: 10px;"> STR ARC TRNS PT </div>	

- STR** To add a straight line.
- ARC** To add a circular curve.
- TRNS** To add a transition curve.
- PT** To add a curve using the intersection method.

Step-by-Step

 When accessing **HC list** from Road menu, the currently defined road elements are displayed in the "HC list" screen. For each element, the type and the Northing coordinate are displayed.

1. To add road elements for horizontal curve, press **Add**.

2. The "Horizon Curve" screen displays the current chainage and azimuth.
 - To add a straight line, press **STR**. Enter azimuth and distance. Press **OK**.
 - To add a circular curve, press **ARC**. Enter radius and length. Press **OK**.
 - To add a transition curve, press **TRNS**. Enter radius and length. Press **OK**.
 - To add a curve using the intersection method, press **PT**. Enter Northing and Easting coordinates of the intersection point, the curve radius and values for A1 and A2. Press **OK**.

 If there is no start point defined, the screen "Define start Pt" is displayed before you can add any other element. Enter chainage, Northing and Easting coordinates. Press **OK**.

3. Add as many elements as desired. To return to the "HC list" screen, press the **ESC** key.

"HC list" screen

- To select a road element, press the **UP/DOWN** keys.
- To view details of the selected road element, press **View**.
 - To return to the "HC list" screen, press the **ESC** key.
 - To edit the data of the road element, press **Edit**.
 - To view details of the previous road element, press **PREV**.
 - To view details of the next road element, press **NEXT**.
- To delete a selected road element, press **Delete**. A start point cannot be deleted.

Next step

To save the entered road data and return to the road menu, press **Save** or the **ESC** key.

9.9.4

Vertical Curve Definition

Description

A vertical curve consists of several intersection points, 30 at maximum. An intersection point is defined by chainage, elevation and curve length. The curve lengths of start point and last intersection point must be zero.

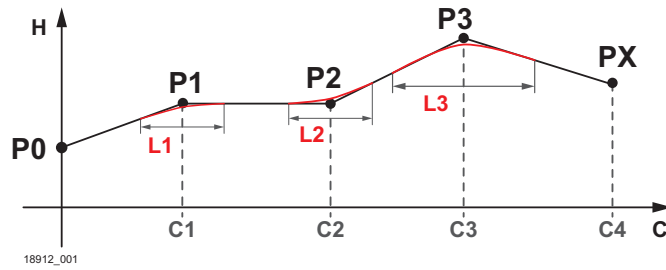

- P0** Start point
- P1, P2, P3** Intersection points
- PX** Last intersection point
- H** Elevation
- C1, C2, C3,** Chainage of respective intersection point
- CX**
- L1, L2, L3** Curve length of respective intersection point

Access

Select **Vert. curve list** (3) from the Road menu.

Define a vertical curve

"Vert. curve list" screen

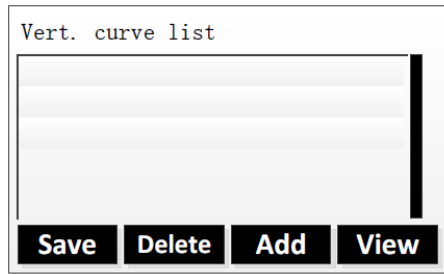

- Save** To save the entered road data.
- Delete** To delete the selected point.
- Add** To add intersection points.
- View** To view details of the selected point.

Step-by-Step

☞ When accessing **Vert. curve list** from Road menu, the currently defined points are displayed in the "Vert. curve list" screen. For each point, the type and the Northing coordinate are displayed.

1. To add intersection points for vertical curve, press **Add**.
2. To define an intersection point, enter values for chainage, elevation and curve length. Press **OK**.

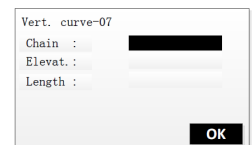

☞ If there is no start point defined, the screen "Define start Pt" is displayed before you can add an intersection point. Enter values for chainage and elevation. Curve length must be zero. Press **OK**.

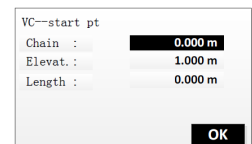

3. Add as many intersection points as desired, 30 at maximum. To return to the "HC list" screen, press the **ESC** key.

"Vert. curve list" screen

- To select a point, press the **UP/DOWN** keys.
- To view details of the selected point, press **View**.
 - To return to the "Vert. curve list" screen, press the **ESC** key.
 - To edit the data of the selected point, press **Edit**.
 - To view details of the previous point, press **PREV**.
 - To view details of the next point, press **NEXT**.
- To delete a selected point, press **Delete**.
A start point cannot be deleted.

Next step

To save the entered road data and return to the road menu, press **Save** or the **ESC** key.

9.9.5

Road Stakeout

Description

Road Stakeout is an application used to measure or stake out points relative to a defined element. The element can be a line or curve. Refer to "9.9.3 Horizontal Curve Definition" and "9.9.4 Vertical Curve Definition".

Chainage, incremental stakeouts and offsets (left and right) are supported. Stake out the centreline first, then left and right pile.

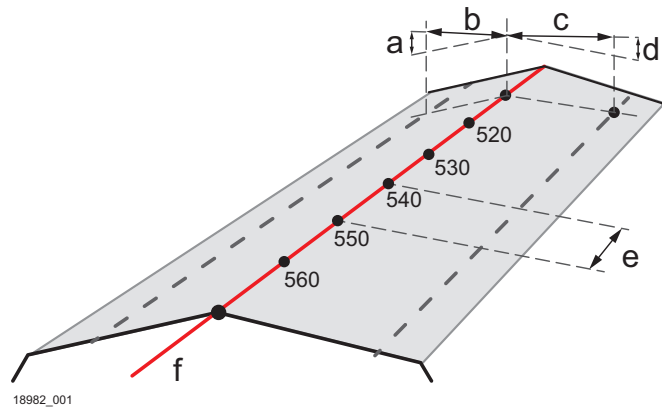

- a Left elevation: vertical distance between left pile and centreline
- b Left offset: horizontal distance between left pile and centreline
- c Right offset: horizontal distance between right pile and centreline
- d Right elevation: vertical distance between right pile and centreline
- e Increment
- f Centreline

Access

Select **Road Stakeout** (4) from the Road menu.

Road stakeout screens

As for point stakeout, there are three stakeout modes available. To select the desired stakeout mode, press the **PAGE** key.

Polar Stakeout mode:

[Stakeout] 1/3			
Search :		*	
Pt. :		5	
T. H :	1.500 m	1	
△ Hz :	← -13° 29' 60"		
△ / :	---		
△ /H :	---		
ALL	DIST	REC	↓
EDM	Coord.	View	↓
Polar	SO-PT		←

Orthogonal to Station Stakeout mode:

[Stakeout] 2/3			
Search :		*	
Pt. :		6	
T. H :	1.800 m	1	
△ Length: *	0.000 m		
△ Trav. :	← 2.052 m		
△ Z/H :	↑ -1.320 m		
ALL	DIST	REC	↓

Cartesian Stakeout mode:

[Stakeout] 3/3			
Search :		*	
Pt. :		5	
T. H :	2.000 m	1	
△ Y/E :	-0.306 m		
△ X/N :	0.404 m		
△ Z/H :	-1.299 m		
ALL	DIST	REC	↓

Road stakeout step-by-step



When no stakeout data has been saved before in the current road file, you need to define the road parameters first.

1. Enter start chainage and increment. To display the next screen, press **OK**.

2. Enter the chainage parameters:

- Left and right offset
- Left and right reflector height

To display the next screen, press **OK**.

3. *The parameters for centreline at the defined start chainage are displayed.*

- To display the parameters for left or right pile, press the **LEFT/RIGHT** keys.
- To display the parameters for another chainage point, press the **UP/DOWN** keys.
- To edit the currently displayed parameters, press **Edit**.
- To calculate the coordinates at the currently selected chainage point, press **CALC**.

4. • To save the point coordinate data, press **REC**.
If desired, edit the point ID before saving.
• To start staking out the point, press **Stakeout**.
• To calculate coordinates of another chainage point, press the **ESC** key.

Road SO-Right	
Pt. :	K+60.0
N:	115.170 m
E:	462.883 m
Z:	12.079 m
REC	Stakeout

To select the desired stakeout mode, press the **PAGE** key.

- For Polar Stakeout mode, display screen 1/3.
- For Orthogonal to Station Stakeout mode, display screen 2/3.
- For Cartesian Stakeout mode, display screen 3/3.



For a detailed description of the stakeout modes, refer to "Stakeout step-by-step" ("9.3 Stakeout").

5. To exit the application, press the **ESC** key.

9.10 Stakeout Reference Element

9.10.1 Overview

Access

1. Select **Program** (2) from the Main Menu.
2. Press the **PAGE** key to display screen 3. Select **Reference Element** (9) from the Program menu.
3. Complete application pre-settings. Refer to "8 Applications - Getting Started".
4. To display the Reference Element menu, select **Start**.
5. Reference Element menu:
 - To define a reference line, select **RefLine**. Refer to "9.10.2 Reference Line".
 - To define a reference arc, select **RefArc**. Refer to "9.10.3 Reference Arc".

9.10.2 Reference Line

Description

RefLine is an application that facilitates the stakeout or checking of lines, for example, for buildings, sections or road, or simple excavations. It allows the user to define a reference line and then complete the following tasks for that line:

- Stakeout Grid
- Measure Line&Offset
- Orthogonal Stakeout
- Segment Stakeout

A reference line can be defined by referencing a known baseline. The reference line can be offset either longitudinally, in parallel or vertically to the baseline, or be rotated around the first base point as required. Furthermore the reference height can be selected as the first point, second point or interpolated along the reference line.

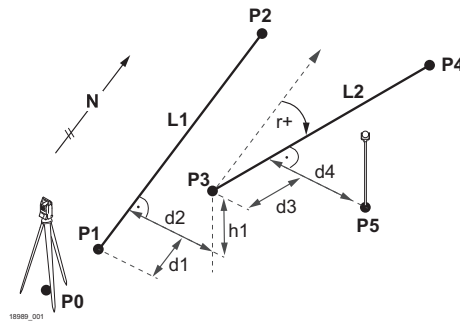

Known:

- P0 Instrument station
- P1, P2 First and second base point
- P3, P4 First and second reference point
- L1 Baseline
- L2 Reference line
- d1 Longitudinal offset of reference line
- d2 Perpendicular offset of reference line
- r+ Rotation parameter
- h1 Height offset of reference line

Unknown:

- P5 Measurement point
- d3 Longitudinal offset of measurement point from reference line
- d4 Perpendicular offset of measurement point from reference line

Define the baseline

The baseline is fixed by two base points. All points can be either measured, manually entered, or selected from the memory.

[Reference Line]			
Measure to first point!			
PT1 :		1	
T. H. :		2.000 m	
▲ :		10.536 m	
▲ :		8.361 m	
ALL	DIST	REC	↓
Find	List	Coord.	↓
EDM			←

Defining the baseline

1. Set the first base point.

Next step

Define the reference line.

Define the reference line

The baseline can be offset from, either longitudinally, in parallel or vertically, or be rotated around the first base point. This new line created from the offsets is called the reference line. All measured data refers to the reference line.

[Reference Line-Main] 1/2			
Length :		360.555 m	
Enter values to shift line!			
Offset :		5.000 m	
Line :		2.000 m	
Height :		10.536 m	
Rotate :		1° 02' 03"	
Grid	Meas.	Stake	↓
NewBL	Zero	Segment	←

[Reference Line-Main] 2/2			
PT1 :		1	
PT2 :		2	
Length :		360.555 m	
Select Height Reference!			
Ref. Hgt :		PT1	↕
Grid	Meas.	Stake	↓
NewBL	Zero	Segment	←

Softkey level 1

- Grid** To stake out a grid relative to the reference line.
- Meas.** To measure line and offset
- Stake** To stake out points orthogonal to the reference line.

Softkey level 2

- NewBL** To define a new baseline.
- Zero** To reset all offset values to 0.
- Segment** To subdivide a reference line into a definable number of segments and stake out the new points on the reference line.

Field	Description
Ref.Hgt	Select an option: <ul style="list-style-type: none"> • PT1 Height differences are computed relative to the height of the first reference point. • PT2 Height differences are computed relative to the height of the second reference point. • Equal Height differences are computed along the reference line. • None Height differences are not computed or shown.

Defining the reference line

1. Use the **UP/DOWN** keys to select an editable field.
Enter the necessary parameters to define the reference line.
2. To display the next screen, press the **PAGE** key.
3. Use the **LEFT/RIGHT** keys to select an option for the reference height.

Next step

Select a softkey option to proceed to a subapplication:

- Stakeout Grid: Refer to "Stakeout grid".
- Measure Line&Offset: Refer to "Measure Line&Offset".
- Orthogonal Stakeout: Refer to "Orthogonal stakeout".
- Segment Stakeout: Refer to "Segment stakeout".

Stakeout grid

The Stakeout Grid subapplication calculates and displays the stakeout elements for the points on the grid. The grid is defined without boundaries. It can be extended over the first and second base points of the reference line.

Defining the grid

1. Use the UP/DOWN keys to select an editable field.
Enter start chainage, increment and transverse to define the grid points.
2. To start staking out the grid points, press **OK**.

[Grid Definition]

Enter start chainage of grid!

Start Chain: 1.147 m

Increment grid points

Increment : 2.258 m

Transverse: 3.369 m

Back OK

Staking out a grid point

[Stakeout Grid]		1/2
PT :		3
T. H. :	2.000	m
Offset<-> :	3.369	↕
chainage:	1.147	↕
Δ Hz : →	1° 02' 03"	
Δ ↙ : ↑	1.256	m
ALL		DIST REC EDM

- To select a grid point, select "Offset" or "chainage" and use the **LEFT/RIGHT** keys.
- To select the desired stakeout mode, press the **PAGE** key.
 - For Polar Stakeout mode, display screen 1/2.
 - For Orthogonal to Station Stakeout mode, display screen 2/2.



For a detailed description of stakeout modes, refer to "9.3 Stakeout".

Measure Line&Offset

The Measure Line&Offset subapplication calculates longitudinal offsets, parallel offsets and height differences of a measured or stored target point relative to the reference line.

[Measure Line&Offset]	
PT. :	4
T. H. :	2.000 m
Δ Length:	3.369 m
Δ trav. :	1.147 m
Δ ↙ :	1.256 m
ALL DIST REC ↓	

- Set the target point.
- After setting the target point, the offsets and height differences are calculated.

Orthogonal stakeout

The Orthogonal Stakeout subapplication calculates the difference between a measured point and the calculated point. The orthogonal and polar differences are displayed.

Defining the offset parameters

[Orthogonal Stakeout]	
Enter orth. stakeout values!	
PT. :	3
T. H. :	2.000 m
EndW. OS :	9.876 m
Transverse:	8.765 m
Z :	7.654 m
Back Reset OK	

1. Use the **UP/DOWN** keys to select an editable field.
Enter the necessary offset parameters.
The software calculates the resulting point coordinates.
-
2. To start staking the calculated point, press **OK**.

Staking out the calculated point

[Orthg. Stakeout]		1/2	
PT.	:	3	
T.H.	:	2.000 m	
Δ Hz	:	\rightarrow 1° 02' 03"	
Δ	:	\uparrow -146.573 m	
Δ	:	\uparrow -15.842 m	
All	DIST	REC	\downarrow
NEXT PT	EDM	Back	\leftarrow

1. To select the desired stakeout mode, press the **PAGE** key.
 - For Polar Stakeout mode, display screen 1/2.
 - For Orthogonal to Station Stakeout mode, display screen 2/2.



For a detailed description of stakeout modes, refer to "9.3 Stakeout".

2. To stake out another point, press **NEXT PT**.

Segment stakeout

The Segment Stakeout subapplication calculates and displays the stakeout elements for points along the reference line. Line Segmentation is limited to the reference line, between the defined start and end points of the line.

Defining the segments

1. Use the **UP/DOWN** keys to select an editable field.
Enter either the number of segments, or the length of segments and define how the remaining line length is treated.
-
2. To start staking the first segment, press **OK**.

[Segment Definition]	
Line Length:	360.555 m
Segment Length:	60.000 m
Segment No. :	7
Misclosure:	0.555 m
Segment :	Start \updownarrow
Back	OK

Staking out a segment point

1. To select a segment point for staking, select "Segment No." or "Cum. Length" and press the **LEFT/RIGHT** keys.
-
2. To select the desired stakeout mode, press the **PAGE** key.
 - For Polar Stakeout mode, display screen 1/2.
 - For Orthogonal to Station Stakeout mode, display screen 2/2.



For a detailed description of stakeout modes, refer to "9.3 Stakeout".

Polar Stakeout mode

[Stakeout Segment]	1/2		
PT. :	3		
T.H. :	2.000 m		
Segment No. :	1		
Cum. Length :	0.555 m		
Δ Hz :	\leftarrow 1° 02' 03"		
Δ :	\uparrow -140.710 m		
ALL	DIST	REC	EDM

Orthogonal to Station Stakeout mode

[Stakeout Segment]	2/2		
PT. :	3		
Cum. Length :	0.555 m		
Segment No. :	1		
Δ Length:	\uparrow 130.644 m		
Δ Trav. :	\leftarrow -52.216 m		
Δ :	\uparrow -8.188 m		
ALL	DIST	REC	EDM

9.10.3

Reference Arc

Description

RefArc is an application that allows the user to define a reference arc and then measure line and offset of a point with respect to that arc.

The reference arc can be defined by:

- a centre point and a start point,
- a start point, an end point and the tangent angles.

Define arc by centre and start point

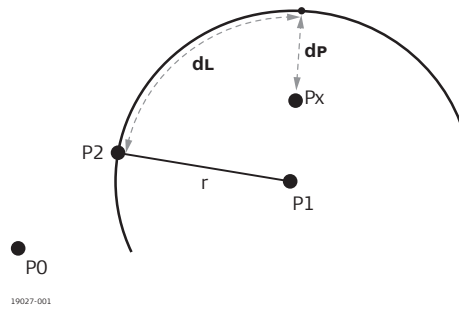



- P0 Instrument station
- P1 Centre point
- P2 Start point
- Px Target point
- dL Δ Line
- dP Δ Offset

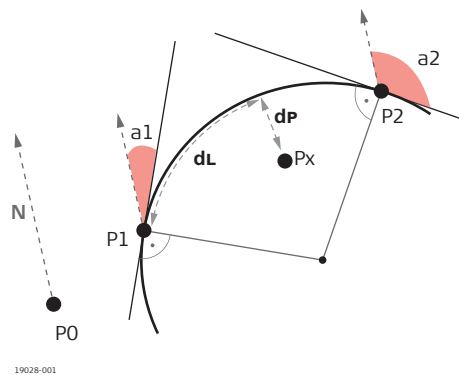

Define arc by start point, end point and tangent angles



- P0 Instrument station
- P1 Start point
- P2 End point
- a1 Tangent angle of start point
- a2 Tangent angle of end point
- Px Target point
- dL Δ Line
- dP Δ Offset

Define arc by centre and start point

[RefArc]			
Measure to centre point!			
CtrPt	:		1
T. H.	:	2.000	m
	:	10.536	m
	:	8.361	m
ALL	DIST	REC	↓
Find	List	Coord.	↓
EDM			←

[RefArc]			
Measure to start Point!			
Start	:		1
T. H.	:	2.000	m
	:	10.536	m
	:	8.361	m
ALL	DIST	REC	↓
Find	List	Coord.	↓
EDM			←

Defining the reference arc by centre and start point



- After starting the **RefArc** application, choose the method for defining the reference arc.
Select **Centre, Start Point (1)**.



- Set the centre point.

- Set the start point of the arc in the same way.
 Centre and start point must not be the same.

- After setting centre and start point, the main screen of RefArc application is displayed.

Define arc by start and end point and tangent angles

[RefArc]			
Measure to start Point!			
Start	:		1
T. H.	:	2.000	m
	:	10.536	m
	:	8.361	m
ALL	DIST	REC	↓
Find	List	Coord.	↓
EDM			←

[RefArc]			
Measure to end Point!			
EndPt	:		2
T. H.	:	2.000	m
	:	10.536	m
	:	8.361	m
ALL	DIST	REC	↓
Find	List	Coord.	↓
EDM			←

Defining the reference arc by start and end point and tangent angles

- After starting the **RefArc** application, choose the method for defining the reference arc.
Select **Start&End Pt, Angle (2)**.

- Set the start point.

- Set the end point of the arc in the same way.
After setting start and end point, the screen for entering tangent angles is displayed.

- Enter the tangent angles for start point (AZ1) and end point (AZ2).
To confirm and display the main screen of RefArc application, press **OK**.

-  If the entered data are not valid, an information message is displayed. To enter different data, press Yes. To cancel and start defining a new arc, press ESC.
If the entered data are valid, the main screen of RefArc application is displayed.

Measure Line&Offset

The Measure Line&Offset subapplication calculates longitudinal offsets, parallel offsets and height differences of a measured or stored target point relative to the reference arc.

[Measure Line&Offset]			
Pt.	:		4
T.H.	:	2.000	m
Δ Line	:	130.644	m
Δ Offset:		-52.216	m
Δ 	:	-8.188	m

ALL DIST REC ↓

1. Set the target point.
 2. *After setting the target point, offsets and height difference are calculated.*
-

10

Data Management

10.1

Overview

Access

1. Select **Manage** (3) from the Main Menu.
2. To select an application in the Manage menu, press a function key, **F1 - F4**. To toggle through the available screens, press the **PAGE** key.
 - To manage jobs, select **Job** (1). Refer to "10.2 Managing Jobs".
 - To manage fix points, select **Fix Pt.** (2). Refer to "10.3 Managing Fix Points".
 - To manage measurement data, select **Meas. PT** (3). Refer to "10.4 Managing Measurement Data".
 - To manage codes, select **Code** (4). Refer to "10.5 Managing Codes".
 - To display memory info or format the memory, select **Mem. Stat.** (5). Refer to "10.6 Managing Memory Space".

Data Manager menu

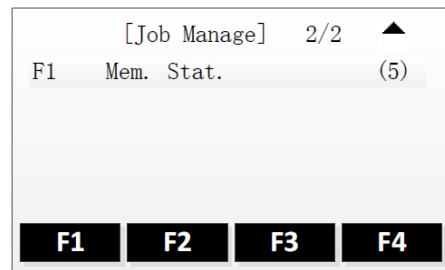
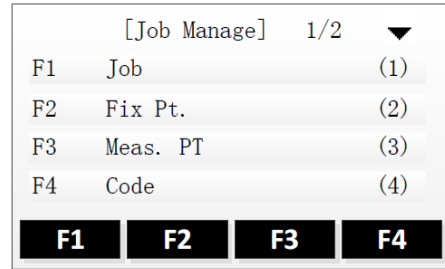

Menu item	Description
Job	To view, create and delete jobs. Jobs are a summary of data of different types, for example, known points, measurements or codes. The job definition consists of the job name and user. The system generates time and date at the time of creation.
Fix Pt.	To view, create, edit and delete fixpoints. Valid fixed points contain at least the point ID and the coordinates E, N or H.
Meas. PT	To view and delete measurement data. Measurement data available in the internal memory can be searched for via a specific point search, or by viewing all points within a job.
Code	To view, create, edit and delete codes. To each code a description and a maximum of 8 attributes with up to 12 characters each can be assigned.
Mem. Stat.	To display the memory usage for internal memory or external memory, if an SD card is inserted. To format the internal memory.
	 Deleting the memory cannot be undone. After confirming the message all data is permanently deleted.

10.2

Managing Jobs

Select, create or delete jobs

- Delete** To delete the selected job. To confirm deletion press Yes.
- New** To create a job.
- View** To view the details of the selected job.
- OK** To set the selected job as the active job and return to the Main Menu.



The currently active job is marked with an asterisk (*). It is not possible to delete the currently active job.
If an SD card is inserted, the jobs stored on the SD card are marked with "[SD]".

Creating a job

- To create a job, press **New** in the Job list screen.



If an SD card is inserted, you are prompted to choose the location for storing the job.

- To select the internal memory, highlight **A:Local Disk** and press **OK**.
- To select the external memory of the SD card, highlight **B:SD Card** and press **OK**.

- Enter a name of the new job. If necessary, enter operator name and additional notes.
The system generates time and date at the time of creation.
- To save the new job and set it as the active job, press **OK**.

10.3

Managing Fix Points

View, search, create, edit or delete fix points

The "View FixPoint" screen displays the fix points contained in the currently active job. At the top right corner, the total number of fix points within the job is displayed.

Softkey level 1

- Find** To search for a fixpoint within the job.
- New** To create a fix point within the current job.
- Edit** To edit.

Softkey level 2

- Delete** To delete fixpoints from the selected job.
- Job** To select another job.

10.4

Managing Measurement Data

View or delete measurement data

Search mode

- Job** To select another job.
- View** To view the search results.

Search results

[View Meas Pt] 1/28 ▼	
Pt. :	6
Job :	DEFAULT
Type :	Meas.
HA :	226° 43' 06"
VA :	89° 26' 11"
Date :	2015.05.23
Delete	Search

Delete To delete measurement data.
Search To display the search mode screen.

10.5

Managing Codes

View, create or delete codes

[View Code] 1/5 ▼	
Code :	TREE ◀▶
Note :	
Info 1 :	GREEN
Info 2 :	
Info 3 :	
Info 4 :	
Find	New Delete

Find To search for a code.
New To enter a new code.
Delete To delete the selected code.

10.6

Managing Memory Space

View memory space or format memory

[Disk List]	
A:Local Disk	
B:SD	
Prop.	Format OK

Prop To view properties for the selected disk.
Format To format internal memory (local disk). Confirm with yes.

[Disk Info.]	
Disk Name :	A:Local Disk
Disk Space:	2036 KB
Used Space:	48 KB
Free Space:	1988 KB
Format	OK

Format To format internal memory.



If an SD card is inserted, "B:SD" is displayed in "Disk List" screen.



Formatting the memory cannot be undone. After confirming the message all data is permanently deleted.

The function "Format" is not supported for SD card.

11

Data Transfer

11.1

Overview

Access

1. Select **Transfer** (4) from the Main Menu.
2. To select an application in the Transfer menu, press a function key, **F1** or **F2**.
 - To open the Import menu, select **Import** (1). Refer to "11.2 Importing Data".
 - To open the Export menu, select **Export** (2). Refer to "11.3 Exporting Data".

Description

The Transfer function allows data transfer between instrument and a computer, using the RS232C port, or between instrument and a removable storage device (UDisk) using the USB port.



For UDisks, the instrument supports up to 8GB of read/write performance. Do not insert or pull out a UDisk while the transfer application is running, as this might cause an error in the software.

Importable data formats

- GSI
- CSV
- GTS-7
- CASS

Exportable data formats

- GSI
- CSV
- GTS-7
- CASS
- HTF

11.2

Importing Data

Importing fix point or code data

Importing fix point data

You can import fix point data to the internal memory either using the USB port or the RS232C port.

1. To import fix point data, select **Fix Pt.** (1) from the Import menu.



Do not insert or pull out a UDisk while the transfer application is running, as this might cause an error in the software. Insert the UDisk before selecting the import method "UDisk".

2. To select the import method, press the **LEFT/RIGHT** keys.

3. **For RS232C:**

- To define the target job to which the imported fix points should be added, press **Job**.
- Connect the instrument to the computer using the RS232C cable.
- Start the transfer software on the computer and press **Send**.

For UDisk:

- To select the data file to be imported from the UDisk, press **Source**.
- To select the file format, select the field "Format" and press the **LEFT/RIGHT** keys.
- To define the target job to which the imported fix points should be added, press **Job**.

4. To start import process, press **Import**.
When import process is finished, the number of imported fix points is displayed.

RS232C port

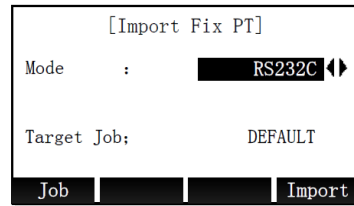

Job To select the target job.
Import To start the import process.

USB port

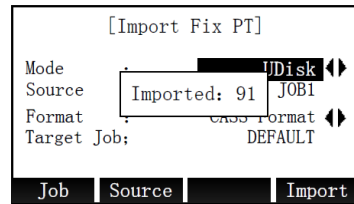

Job To select the target job.
Source To select the data file to be imported.
Import To start the import process.

Importing code data

You can import code data to the internal memory using the RS232C port only.

1. To import code data, select **Code Data** (2) from the Import menu.
2. Connect the instrument to the computer using the RS232C cable.
3. Start the transfer software on the computer and press **Send**.
4. To start import process, press **Import**.
The code data are added to the code library.

11.3

Exporting Data

Exporting job or code data

Exporting job data

You can export job data -that is, fix points or measurement data - from the internal memory either using the USB port or the RS232C port.

1. To export job data, select **Job Data** (1) from the Export menu.
 Do not insert or pull out a UDisk while the transfer application is running, as this might cause an error in the software.
Insert the UDisk before selecting the export method "UDisk".
2. To select the export method, select the field "Mode" and press the **LEFT/RIGHT** keys.
3. **For RS232C:**
 - To define the job to be exported, press **Job**.
 - To select the data to be exported, select the field "Data Type" and press the **LEFT/RIGHT** keys.
 - Connect the instrument to the computer using the RS232C cable.
 - Start the transfer software on the computer.**For UDisk:**
 - To define the job to be exported, press **Job**.
 - To select the data to be exported, select the field "Data Type" and press the **LEFT/RIGHT** keys.
 - To select the file format, select the field "Format" and press the **LEFT/RIGHT** keys.
4. Press **Export** to start export process.

RS232C port

```
[Job Data]
Job      :          DEFAULT
Data Type:          Meas. PT ◀▶
Mode     :          RS232C ◀▶
```

Job | | | Export

Job To select the job to be exported.
Export To start the export process.

USB port

```
[Job Data]
Job      :          DEFAULT
Data Type:          Meas. PT ◀▶
Mode     :          UDisk ◀▶
Format  :          Meas Fmt (*.htf) ◀▶
```

Job | | | Export

Job To select the job to be exported.
Export To start the export process.

Exporting code data

You can export code data from the internal memory using the RS232C port only.

1. To export code data, select **Code Data** (2) from the Export menu.
2. Connect the instrument to the computer using the RS232C cable.
3. Start the transfer software on the computer.
4. Press **Export** to start export process.

11.4

Working with X-Pad

Description

The software X-Pad is used for the data exchange between the instrument and a computer. It contains several auxiliary programs in order to support the instrument.



For more information about X-Pad, contact your GeoMax AG representative.

12

Check & Adjust

12.1

Overview

Description

GeoMax instruments are manufactured, assembled and adjusted to a high quality. Quick temperature changes, shock or stress can cause deviations and decrease the instrument accuracy. It is therefore recommended to calibrate the instrument from time to time. This can be done in the field by running through specific measurement procedures. The procedures are guided and have to be followed carefully and precisely as described in the following chapters. Some other instrument errors and mechanical parts can be adjusted mechanically.



During the manufacturing process, the instrument errors are carefully determined and set to zero. As mentioned, these errors can change and it is highly recommended to redetermine them in the following situations:

- Before the instrument is used for the first time.
- Before every high precision survey.
- After rough or long periods of transport.
- After long periods of work or storage.
- If the temperature difference between current environment and the temperature at the last calibration is more than 10°C (18°F).



For determining these errors, it is necessary to measure in both faces, but the procedure can be started in any face.

12.2

Preparation

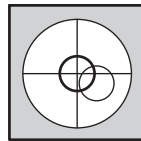

Before determining the instrument errors, the instrument has to be levelled using the electronic level. The tribrach, the tripod and the underground should be stable and secure from vibrations or other disturbances.



The instrument should be protected from direct sunlight in order to avoid thermal expansion on one side only.



Before starting to work, the instrument has to become acclimatised to the ambient temperature. Approximately two minutes per °C of temperature difference from storage to working environment, but at least 15 min, should be taken into account.

12.3

Adjustments

Access

1. Select **Tools** from the Main Menu.
2. Select **Adjust** from the Tools menu.
3. To select an option in the Adjust menu, press a function key, F1 - F4. To toggle through the available screens, press the **PAGE** key.

Adjust menu

Menu selection	Description
View Adjust Param.	Displays the current value of vertical index error and the parameters of tilt sensor.
Adjust Index Error	Refer to "12.4 Adjust Index Error".
Adjust Tilt X	Refer to "12.5 Adjust Tilt X / Tilt Y".
Adjust Tilt Y	Refer to "12.5 Adjust Tilt X / Tilt Y".

Menu selection	Description
Const. Setting	Allows to set the values for additive and multiplying constant.
Factory settings	Allows to reset all instrument settings to the factory default.

12.4

Adjust Index Error

Vertical index error

The vertical circle should read exactly 90° (100 gon) when the line of sight is horizontal. Any deviation from this figure is termed vertical index error. This is a constant error that affects all vertical angle readings.

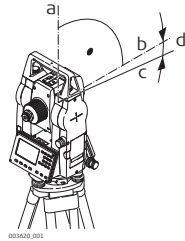

- a Mechanical vertical axis of the instrument, also called standing axis
- b Axis perpendicular to the vertical axis. True 90°
- c Vertical angle is reading 90°
- d Vertical index error



By determining the vertical index error the electronic level is adjusted automatically

Adjust Index Error step-by-step

1. Level the instrument with the electronic level. Refer to "Setup step-by-step" and "Electronic level and laser plummet".



Activate the compensator before starting the adjustment procedure.

2. Aim at the target point.

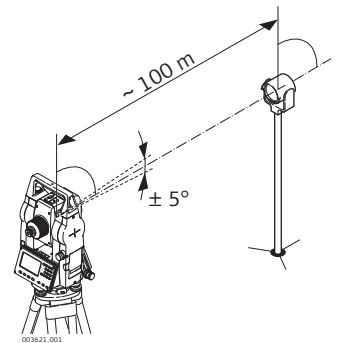

3. Press **OK** to measure to the target point.

4. Change face and aim at the target point again

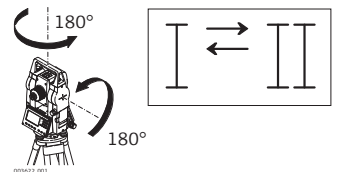

5. Press **OK** to measure to the target point.
The old and new calculated values are displayed.

6. Either:
 - Press **OK** to save the new calibration data, or
 - Press **ESC** to exit without saving the new calibration data.

12.5

Adjust Tilt X / Tilt Y

Adjust tilt X or tilt Y

1. Select the respective option in the Adjust menu.
 2. Follow the on-screen instructions for adjusting the x-direction or y-direction of the vertical compensator axis.
 -  If the absolute value of the linear coefficient (CoK) is greater than 1.5, recalibrate the compensator.
 3. To exit without changing the compensator parameters, press **ESC**.
-

13

Care and Transport

13.1

Transport

Transport in the field

When transporting the equipment in the field, always make sure that you

- either carry the product in its original container,
 - or carry the tripod with its legs splayed across your shoulder, keeping the attached product upright.
-

Transport in a road vehicle

Never carry the product loose in a road vehicle, as it can be affected by shock and vibration. Always carry the product in its container and secure it.

For products for which no container is available use the original packaging or its equivalent.

Shipping

When transporting the product by rail, air or sea, always use the complete original GeoMax packaging, transport container and cardboard box, or its equivalent, to protect against shock and vibration.

Shipping, transport of batteries

When transporting or shipping batteries, the person responsible for the product must ensure that the applicable national and international rules and regulations are observed. Before transportation or shipping, contact your local passenger or freight transport company.

Field adjustment

Exposing the product to high mechanical forces, for example through frequent transport or rough handling, or storing the product for a long time may cause deviations and a decrease in the measurement accuracy. Periodically carry out test measurements and perform the field adjustments indicated in the User Manual before using the product.

13.2

Storage

Product

Respect the temperature limits when storing the equipment, particularly in summer if the equipment is inside a vehicle. Refer to "14 Technical Data" for information about temperature limits.

Li-Ion batteries

- Refer to "14 Technical Data" for information about storage temperature range.
 - Remove batteries from the product and the charger before storing.
 - After storage recharge batteries before using.
 - Protect batteries from damp and wetness. Wet or damp batteries must be dried before storing or use.
 - A storage temperature range of 0 °C to +30 °C / +32 °F to +86 °F in a dry environment is recommended to minimize self-discharging of the battery.
 - At the recommended storage temperature range, batteries containing a 40% to 50% charge can be stored for up to one year. After this storage period the batteries must be recharged.
-

13.3

Cleaning and Drying

Objective, eyepiece and reflectors

- Blow dust off lenses and prisms.
 - Never touch the glass with your fingers.
 - Use only a clean, soft, lint-free cloth for cleaning. If necessary, moisten the cloth with water or pure alcohol. Do not use other liquids; these may attack the polymer components.
-

Damp products

Dry the product, the transport container, the foam inserts and the accessories at a temperature not greater than 40°C /104°F and clean them. Do not repack until everything is completely dry. Always close the transport container when using in the field.

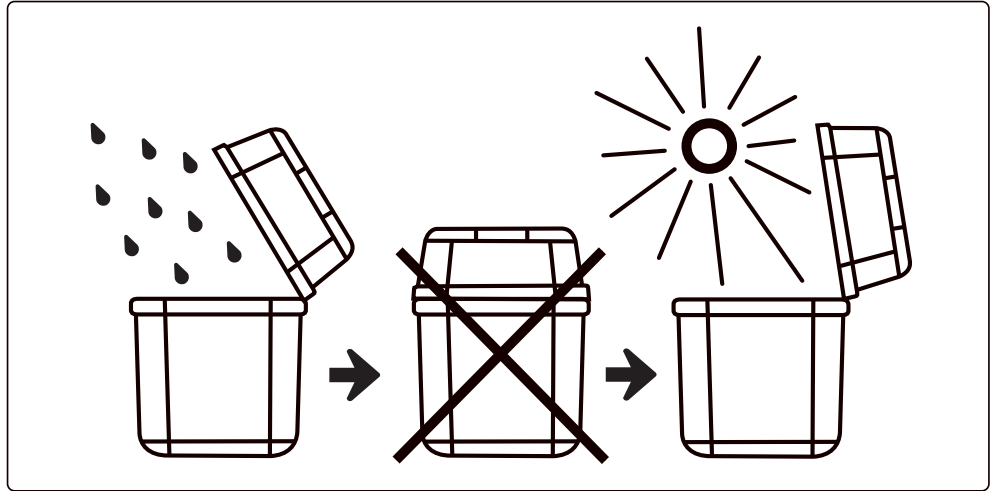

Cables and plugs

Keep plugs clean and dry. Blow away any dirt lodged in the plugs of the connecting cables.

14

Technical Data

14.1

General Technical Data of the Product

Telescope	Magnification:	30x
	Field of View:	1°20' (2.3 m at 100 m)
	Minimum Focusing Distance:	1.5 m
	Reticle:	Illuminated
Compensator	System:	Dual-axis
	Working Range:	±3'
	Setting Accuracy:	1"
Communication	Interface:	<ul style="list-style-type: none">• Standard RS232• SD card*• USB drive with micro USB• Bluetooth
	Internal Data Memory:	approximately 20.000 Points
	Data Format:	ASCII
	* Maximum extension up to 32 GB.	
Operation	Display:	High-resolution backlit black-and-white display with contrast adjustment Graphics: 280 x 160 pixels Characters: 6 lines, each containing up to 25 characters
	Dual Keyboard:	Alphanumeric backlit rubber keyboard

Instrument Dimensions

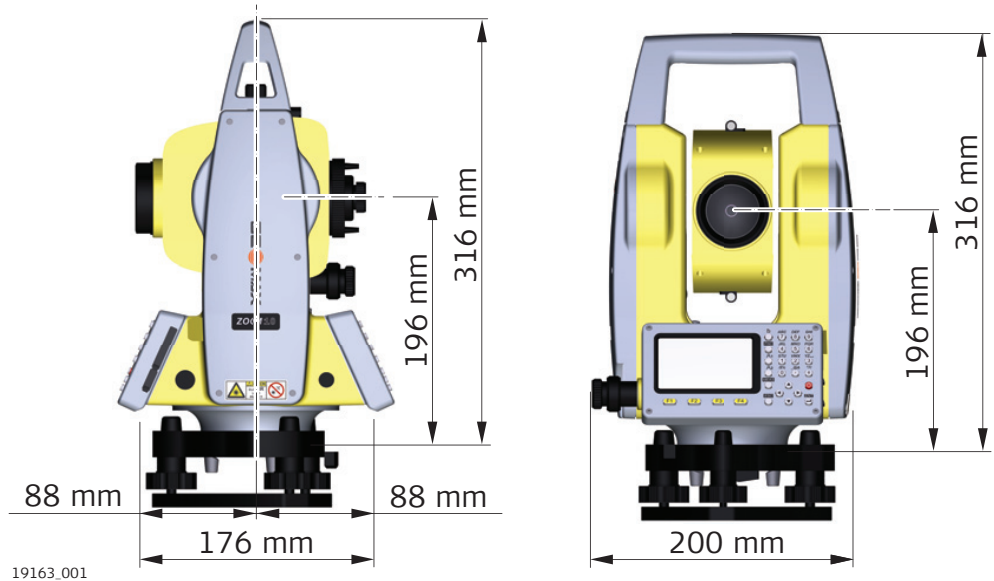

Laser plummet

Type:	Laser plummet with four brightness levels. No optical plummet.
-------	---

Centring Accuracy: 1 mm at 1.5 m instrument height.

Power supply

Battery Type: Rechargeable Li-Ion battery
Voltage/Capacity: ZBA10: 7.4 V DC/3000 mAh
Operating time with ZBA10: 16 h* (optimal) - continuous angle measurement every 30 s
10 h (typical)
Measuring times: About 12000 times

* New battery at 25°C, 24 h continuously angle measurement mode

Environmental specifications

Temperature

Type	Operating temperature		Storage temperature	
	[°C]	[°F]	[°C]	[°F]
Instrument	-20 to +50	-4 to +122	-40 to +70	-40 to +158
Battery	-20 to +50	-4 to +122	-40 to +70	-40 to +158

Protection against water, dust and sand

Type	Protection
Instrument	IP54 (IEC 60529)

14.2

Angle Measurement

Measurement Method: Absolute Encoding
Minimum Readout: 1"/5"/10" (0.3 mgon/1.5 mgon/3 mgon)
Accuracy*: 2"

* Accuracy with standard deviation based on ISO 17123-3.

14.3

Distance Measurement with Reflectors

Reflector	Range
Single prism	3000 m under good condition*
Three prisms	6000 m under good condition*
Reflective sheet	800 m

* Good condition: no haze, visibility about 40 km, moderate sunlight.

Accuracy: 2 mm + 2 ppm
Measuring time (Fine/Quick/Tracking): 1.5 s/1 s/0.5 s

14.4

Distance Measurements without Reflectors (Reflectorless mode)



Reflectorless distance measurement requires laser class 3R.

Reflectorless Range* :	350 m
Accuracy:	3 mm + 2 ppm
Measuring time:	1.5 s

* Calculated by Kodak Gray Card white side (90% reflective), exact distance depends on measuring object, observation and environment conditions.

14.5

Conformity to National Regulations

Conformity to national regulations

- FCC Part 15, 22 and 24 (applicable in US)
- Hereby, GeoMax AG declares that the radio equipment type Zoom10 is in compliance with Directive 2014/53/EU and other applicable European Directives. The full text of the EU declaration of conformity is available at the following Internet address: <http://www.geomax-positioning.com/Downloads.htm>.



Class 1 equipment according to European Directive 2014/53/EU (RED) can be placed on the market and be put into service without restrictions in any EEA member state.

- The conformity for countries with other national regulations not covered by the FCC part 15, 22 and 24 or European Directive 2014/53/EU has to be approved prior to use and operation.

Frequency band

Type	Frequency band [MHz]
Bluetooth	2402 - 2480

Output power

Type	Output power [mW]
Bluetooth	2.5

14.6

Scale Correction

Use of scale correction

By entering a scale correction, reductions proportional to distance can be taken into account.

- Atmospheric correction.
- Reduction to mean sea level.
- Projection distortion.

Atmospheric correction

The slope distance displayed is correct if the scale correction in ppm, mm/km, which has been entered corresponds to the atmospheric conditions prevailing at the time of the measurement.

The atmospheric correction includes:

- Adjustments for air pressure
- Air temperature

For highest precision distance measurements, the atmospheric correction should be determined with:

- An accuracy of 1 ppm
- Air temperature to 1 °C
- Air pressure to 3 mbar

Atmospheric corrections °C

Atmospheric corrections in ppm with temperature [°C], air pressure [mb] and height [m] at 60 % relative humidity.

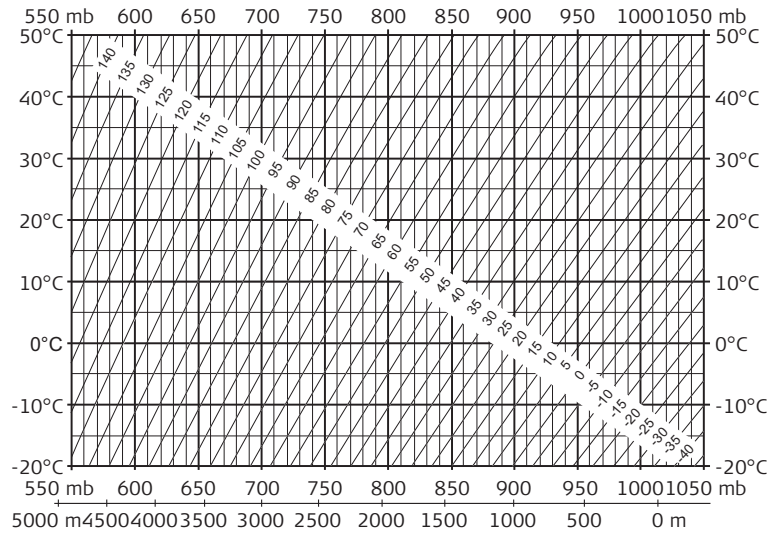

Atmospheric correction °F

Atmospheric corrections in ppm with temperature [°F], air pressure [inch Hg] and height [ft] at 60 % relative humidity.

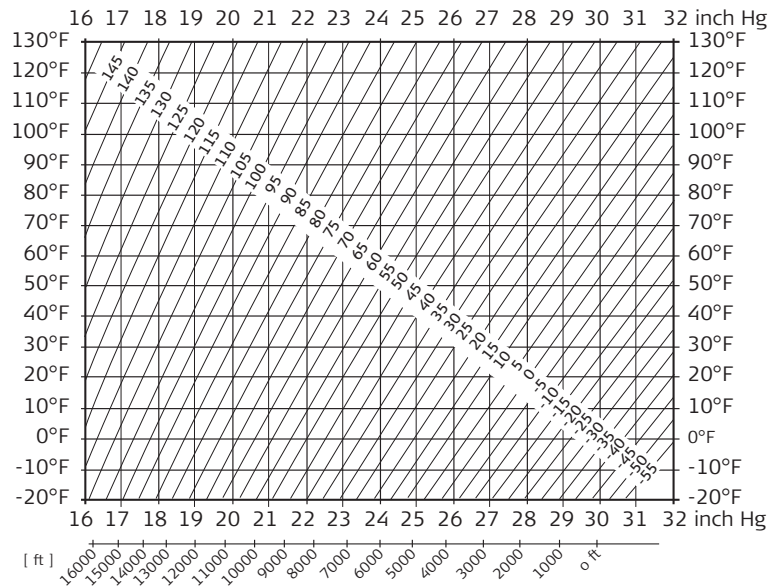

Formulas

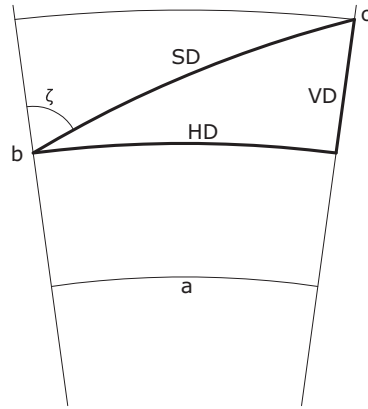

- a Mean Sea Level
- b Instrument
- c Reflector
- SD Slope distance
- HD Horizontal distance
- VD Height difference

The instrument calculates the slope distance, horizontal distance, and height difference in accordance with the following formulas. Earth curvature (1/R) and mean refraction coefficient (k = 0.13) are automatically taken into account when calculating the horizontal distance and height difference. The calculated horizontal distance relates to the station height and not to the reflector height.

Slope distance

$$SD = D_0 \cdot (1 + ppm \cdot 10^{-6}) + p$$

- SD Displayed slope distance [m]
- D0 Uncorrected distance [m]
- ppm Atmospheric scale correction [mm/km]
- p prism constant [m]

Horizontal distance

$$HD = Y - A \cdot X \cdot Y$$

- HD Horizontal distance [m]
- Y SD * |sinζ|
- X SD * cosζ
- A (1 - k/2)/R = 1.47 * 10⁻⁷ [m⁻¹]

ζ = Vertical circle reading
 k = 0.13 (mean refraction coefficient)
 R = 6.378 * 10⁶m (radius of the earth)

Height difference

$$VD = X + B \cdot Y^2$$

- VD Height difference [m]
- Y SD * |sinζ|

$$X = SD * \cos\zeta$$

$$B = (1 - k)/2R = 6.83 * 10^{-8} \text{ [m}^{-1}\text{]}$$

ζ = Vertical circle reading

$k = 0.13$ (mean refraction coefficient)

$R = 6.378 * 10^6 \text{ m}$ (radius of the earth)

Software Licence Agreement

This product contains software that is preinstalled on the product, or that is supplied to you on a data carrier medium, or that can be downloaded by you online according to prior authorisation from GeoMax. Such software is protected by copyright and other laws and its use is defined and regulated by the GeoMax Software Licence Agreement, which covers aspects such as, but not limited to, Scope of the Licence, Warranty, Intellectual Property Rights, Limitation of Liability, Exclusion of other Assurances, Governing Law and Place of Jurisdiction. Please make sure, that at any time you fully comply with the terms and conditions of the GeoMax Software Licence Agreement.

Such agreement is provided together with all products and can also be referred to and downloaded at the GeoMax home page at <http://www.geomax-positioning.com/swlicense> or collected from your GeoMax distributor.

You must not install or use the software unless you have read and accepted the terms and conditions of the GeoMax Software Licence Agreement. Installation or use of the software or any part thereof, is deemed to be an acceptance of all the terms and conditions of such Licence Agreement. If you do not agree to all or some of the terms of such Licence Agreement, you must not download, install or use the software and you must return the unused software together with its accompanying documentation and the purchase receipt to the distributor from whom you purchased the product within ten (10) days of purchase to obtain a full refund of the purchase price.



Depending on local firmware versions the menu items may differ.

Menu Tree

- |-- **Q-Survey**
- |-- **Program**
 - |-- Surveying
 - |-- Stakeout
 - |-- Resection
 - |-- Tie Distance
 - |-- Area
 - |-- Remote Height
 - |-- COGO
 - |-- Road
 - |-- Reference Element
- |-- **Manage**
 - |-- Job
 - |-- Fix Pt.
 - |-- Meas. PT
 - |-- Code
 - |-- Mem. Stat.
- |-- **Transfer**
 - |-- Import Data
 - |-- Export Data
- |-- **Setting**
 - |-- General
 - |-- EDM Setting
- |-- **Tools**
 - |-- Adjust
 - |-- View Adjust Param.
 - |-- Adjust Index Error
 - |-- Adjust Tilt X
 - |-- Adjust Tilt Y
 - |-- Const. Setting
 - |-- Factory Setting
- |-- Info
 - |-- Date Setting
 - |-- Time Setting
 - |-- FW. Upgrade

Appendix B

Glossary

Instrument axis

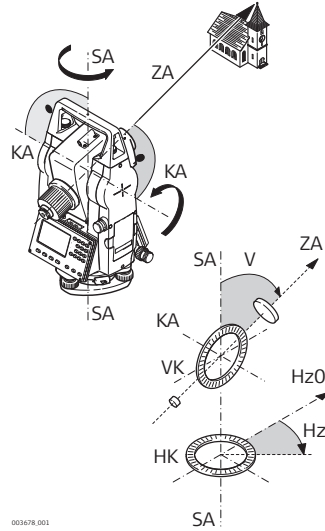

ZA = Line of sight / collimation axis

Telescope axis = line from the cross hairs to the center of the objective.

SA = Standing axis

Vertical rotation axis of the telescope.

KA = Tilting axis

Horizontal rotation axis of the telescope. Also known as the Trunion axis.

V = Vertical angle / zenith angle

VK = Vertical circle

With coded circular division for reading the vertical angle.

Hz = Horizontal direction

HK = Horizontal circle

With coded circular division for reading the horizontal angle.

Plumb line / compensator

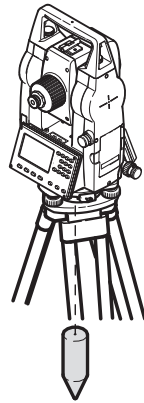

Direction of gravity. The compensator defines the plumb line within the instrument.

Standing axis inclination

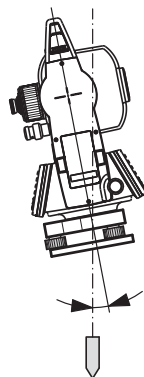

Angle between plumb line and standing axis. Standing axis tilt is not an instrument error and is not eliminated by measuring in both faces. Any possible influence it may have on the horizontal direction or vertical angle is eliminated by the dual axis compensator.

Zenith

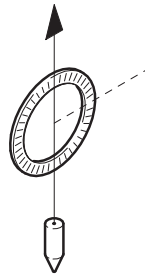

Point on the plumb line above the observer.

Crosshairs

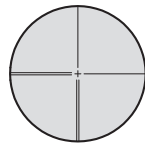

Glass plate within the telescope with reticle.

Line-of-sight error (horizontal collimation)

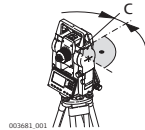

The line-of-sight error (c) is the deviation from the perpendicular between the tilting axis and line of sight. This could be eliminated by measuring in both faces.

Vertical index error

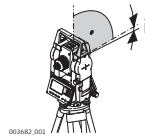

With a horizontal line of sight the vertical circle reading should be exactly 90°(100 gon). The deviation from this value is termed the Vertical index error (i).

Explanation of displayed data

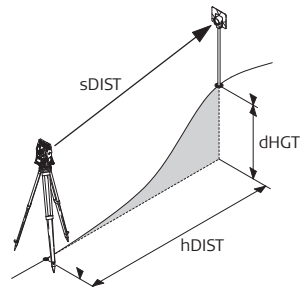

sDIST
Indicated meteorological corrected slope distance between instrument tilting axis and center of prism/laser dot

hDIST
Indicated meteorological corrected horizontal distance

dHGT
Height difference between station and target point



879542-1.0.0en

Original text

© 2019 GeoMax AG, Widnau, Switzerland