



A comprehensive range
of window blind systems
designed with unique
technical features and to
the exacting specifications
that active commercial
environments demand.



YewdaleDefiant® the blind systems range

A comprehensive range of window blind systems designed with unique technical features and to the exacting specifications that active commercial environments demand.



All YewdaleDefiant® blinds are carefully built to exacting standards, giving years of trouble free service. The superior design features and quality components enable them to be confidently specified for the most demanding environments.





YewdaleDefiant® Insect Screens

All YewdaleDefiant® Insect Screens are carefully built to exacting standards, giving years of trouble-free service. The superior design features and quality components enable them to be confidently specified for the most demanding environments.

The provision of insect screens at door and window openings is a legal requirement in areas where food is prepared for public consumption, such as restaurants, works canteens, schools, hospitals and all public buildings. YewdaleDefiant® screens comply with the relevant Health and Safety regulations, and all frame sections are manufactured from hygienic white powder-coated aluminium extrusions. The PVC coated glass fibre mesh is rot-proof and flame-retardant.

The greatly enhanced interior environment provided by YewdaleDefiant® screens is an important contributor to the quality of life in many situations, both residential and commercial. The screens are unobtrusive, with simple and attractive detailing and quality components. The full range is distributed globally through a network of partners providing an unrivalled level of support, and with experienced installation and service teams to exceed your expectations.

F30 Sidewinder	41
F32 Spring	42
F40 Single Door	43
F40D Double Door	43



this insect screen range comes with a Full Lifetime Warranty as standard.



F30 Sidewinder

Features:

The YewdaleDefiant® F30 retractable insect screen utilises a simple bead-chain sidewinder control as standard. White metal universal brackets for secure top fixing with powder-coated extruded aluminium cassette and side guide channels. Rot-proof PVC coated fiber glass mesh is locked into the barrel and bottom bar profile.

Benefits:

The discreet yet attractive profile of the F30 roll-up system provides a perfect solution for almost all types of window or door openings. A strong focus on a trouble-free quality mechanism with high-grade nylon fittings ensures consistency of operation.

Specification:

The YewdaleDefiant® F30 retractable insect screen with sidewinder operation as manufactured by Yewdale, +44 (0)1268 570900. Roll-up flame retardant, rot-proof PVC coated fiber glass mesh within white powder-coated aluminium cassette, guide channels and bottom bar. Supported by sturdy metal brackets and incorporating plastic control chain.

Please refer to NBS Plus N10 240.

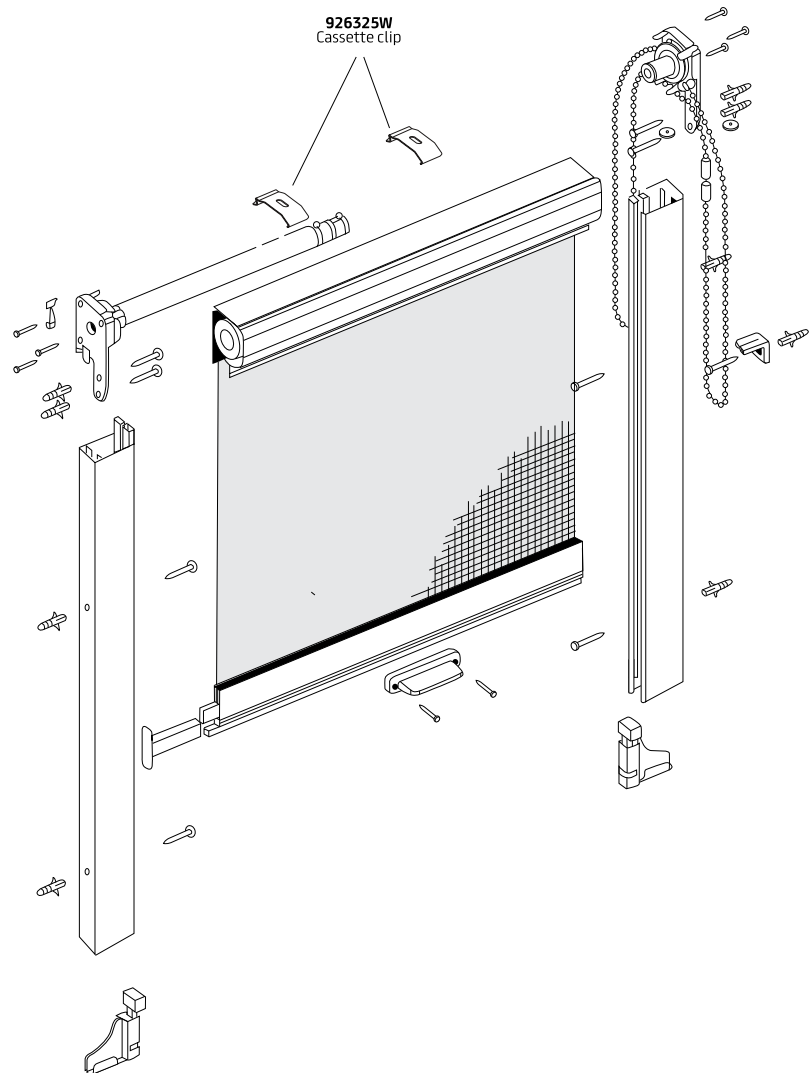

Insect Screen Specification Guide

Model	Min Width	Max Width	Min Drop	Max Drop	Max M ²
F30	800	1600	400	2500	3.5

YewdaleDefiant® Insect Screens

YewdaleDefiant® Insect Screens



F32 Spring

Features:

The YewdaleDefiant® F32 retractable insect screen with advanced slow-rise spring control ensures smooth and quiet operation. White metal universal brackets for secure top fixing with powder-coated extruded aluminium cassette and side guide channels. Rot-proof PVC coated fiber glass mesh is locked into the barrel and bottom bar profile.

Benefits:

The discreet yet attractive profile of the F32 roll-up system will complement the décor of many interiors. Coupled with the ease of the advanced spring operation, this system is perfectly suited to a wide range of both commercial and domestic applications. A strong focus on a trouble-free quality mechanism with high-grade nylon fittings ensures consistency of performance.

Specification:

The YewdaleDefiant® F32 retractable insect screen with advanced slow-rise spring operation as manufactured by Yewdale, +44 (0)1268 570900. Vandal resistant spring and decelerator mechanism is housed within white powder-coated aluminium cassette. Roll-up flame retardant, rot-proof PVC coated fiber glass mesh held securely inside guide channels and bottom bar. Supported by sturdy metal brackets.

Please refer to NBS Plus N10 240.

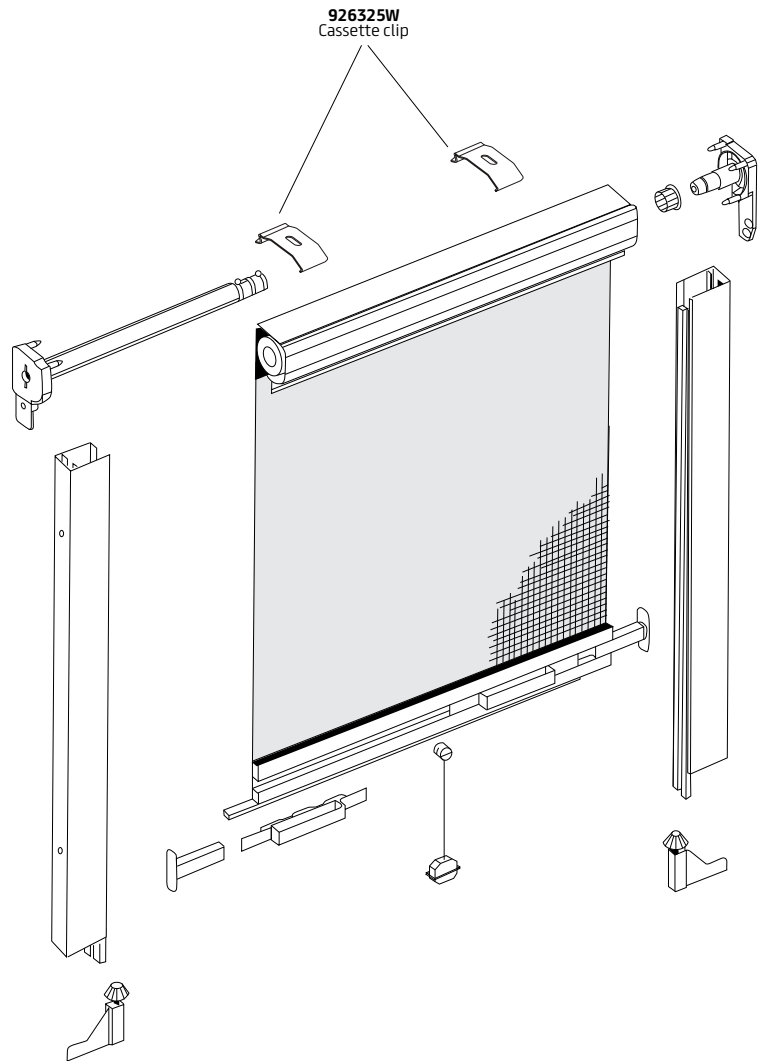

Insect Screen Specification Guide

Model	Min Width	Max Width	Min Drop	Max Drop	Max M ²
F32	600	1800	400	2500	3.5



F40 Single Door F40D Double Door

Features:

The YewdaleDefiant® F40 horizontally retractable insect screen with advanced slow-rise spring control ensures smooth and quiet operation. Available as single door unit (F40) or double door unit (F40D) as applicable. White metal universal brackets for secure top fixing with powder-coated extruded aluminium cassette and side guide channels. Rot-proof PVC coated fiber glass mesh is locked into the barrel and bottom bar profile.

Benefits:

The slim, unobtrusive profile of the F40 roll-up system provides a suitable solution for doorways and large window openings in areas where food preparation is carried out. The 43mm cassette units will complement the décor of many interiors and the advanced spring operation ensures a reliable, consistency of use.

Specification:

The YewdaleDefiant® F40/F40D horizontally retractable single/double insect screen unit with advanced slow-rise spring operation as manufactured by Yewdale, +44 (0)1268 570900. Vandal resistant spring and decelerator mechanism is housed within white powder-coated aluminium cassette. Roll-up flame retardant, rot-proof PVC coated fiber glass mesh held securely inside guide channels and bottom bar. Supported by sturdy metal brackets.

Please refer to NBS Plus N10 240.

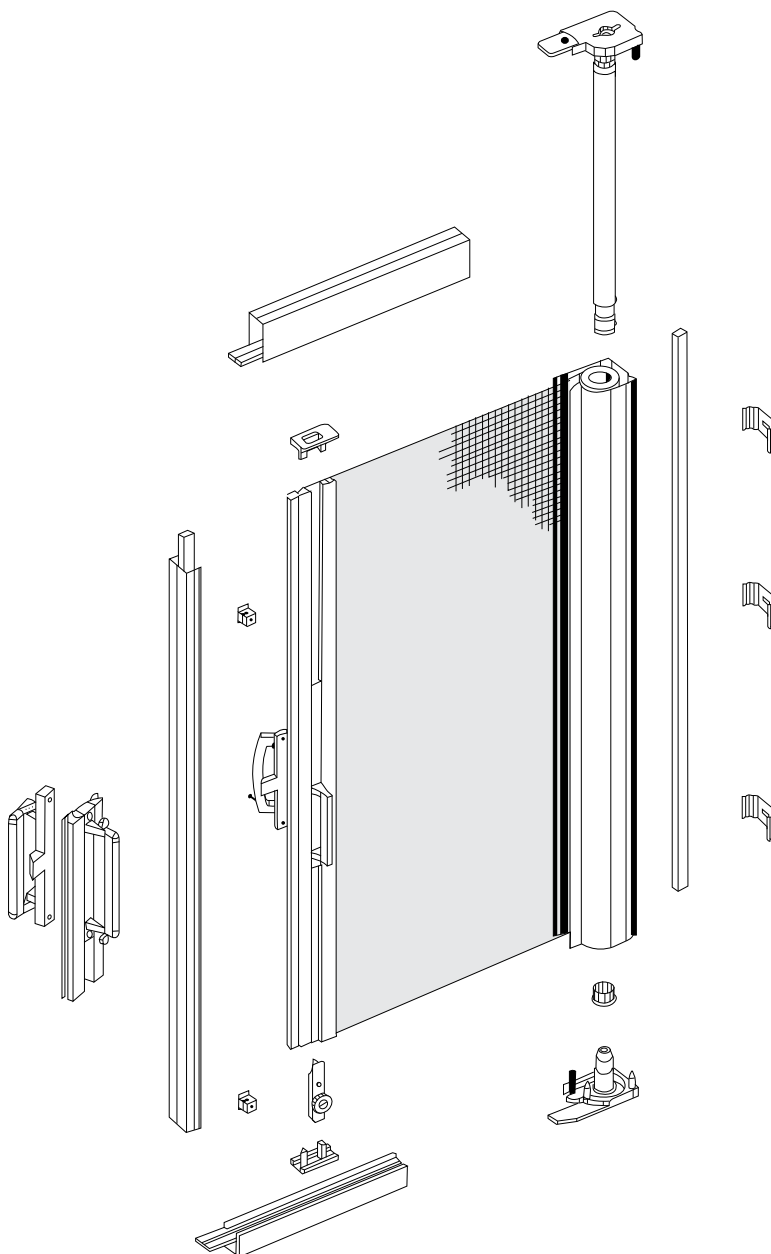

Insect Screen Specification Guide

Model	Min Width	Max Width	Min Drop	Max Drop	Max M ²
F40	400	1200	1000	2500	3.0
F40D	800	2500	1000	2500	6.0