

Transom Remote Control

Model: SEI-SERMTRNS



User Guide

Important

- Please read this User Guide before installation and use.
- A CR2032 coin/button cell Battery is pre-installed in the Transom Remote Control at the factory with a red plastic isolator in the Battery Compartment to preserve battery life before initial use. Before using the Transom Remote Control you **MUST** remove the plastic isolator as follows:

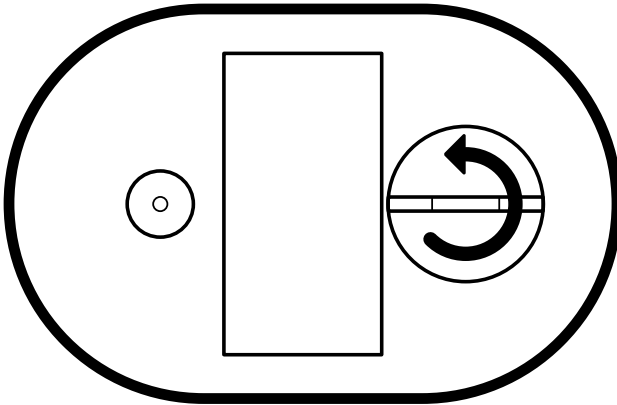

1. Unscrew the Battery Cap at the back of the Transom Remote Control with your fingernail or a coin.
2. Remove the battery and the red plastic isolator sheet.

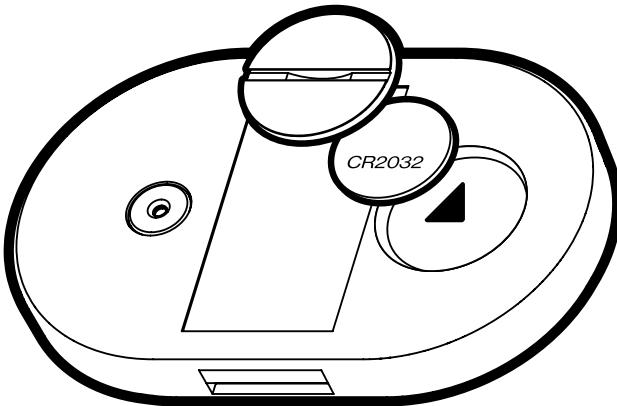

3. Place the battery back in the battery compartment.

IMPORTANT: Ensure the battery's positive side + faces down (towards the device).

4. Carefully place the Battery Cap flat over the battery. Tighten the Cap so the battery is secure in the compartment and sealed from water and dirt.
5. Press a button on the Transom Remote Control and you should see the red LED on the Button Panel flash. If you do not see the red LED flash when you press a button on the Transom Remote Control, open the Battery Cap and check if the battery is properly installed. (Make sure that the battery's positive side is facing the correct direction and in contact with the spring terminal).

WARNING:

- The Transom Remote Control contains an industry standard coin/button cell Battery.
- **DO NOT SWALLOW THE BATTERY.**
- **KEEP NEW AND USED BATTERIES AWAY FROM CHILDREN.**
- If the Battery Compartment does not close securely, stop using the product.
- If the Battery is swallowed, the Battery may cause severe internal burns and may eventually lead to death. If you think a Battery might have been swallowed or placed inside any part of a body, seek immediate medical attention.



Introduction

Features

The Transom Remote Control is an all-in-one device providing audio and LED lighting controls to a paired SoundExtreme product.

Rugged Design and Easy Installation

- IP67 marine grade waterproof.
- Compact size and easy mounting.

RF Remote Transmitter

- The Transom Remote Control has a built-in, long range RF 433 MHz remote transmitter, which is used to pair with and control SoundExtreme audio products.

Pair and Control Multiple Products

- The Transom Remote Control can pair and control up to 3 SoundExtreme products in the Transom Remote Control memory as P1, P2, and P3.

EcoCast and LEDCast: Audio and Lighting Controls

- Audio Mode / Source selection.
- 3-Zone Volume Control: For multi-audio-Zone SoundExtreme products like Marine Radios, with 2 wired Zones and 1 wireless (EcoCast) Zone controls.
- LED Lighting Scene Control: Switch between 5 of the predefined lighting Scenes on the paired SoundExtreme product.

Lighting Control Concepts

Below are some terms and definitions to help you better understand the Lighting Control Concepts associated with LEDCast-enabled SoundExtreme products. Please refer to the paired SoundExtreme product's User Guide for more details.

Zone

A Zone corresponds to all the LED lights that are connected directly to one physical connection on an LED Lighting Controller output. When you change a Zone status (on / off, Mode, etc.), the LEDs connected to that Zone will change accordingly. Depending on the product the Transom Remote Control is paired with, the SoundExtreme product may have 1 to 4 LED lighting Zones.

Mode

There are 3 LED Mode categories, totaling in 44 Modes supported by the Transom Remote Control:

- 8 Color Mode
- 20 Party Mode
- 16 Music Mode

Scene

A Scene is programmed via the SoundExtreme Smartphone App. You can customize each Zone into a Scene (a preset). Setting the Scenes on the app allows a 1-button press to bring up your desired custom settings for all of the LED products connected to the SoundExtreme product. LEDCast-enabled SoundExtreme products have 5 Scene settings.

Transom Remote Control Overview

Transom Remote Control Layout

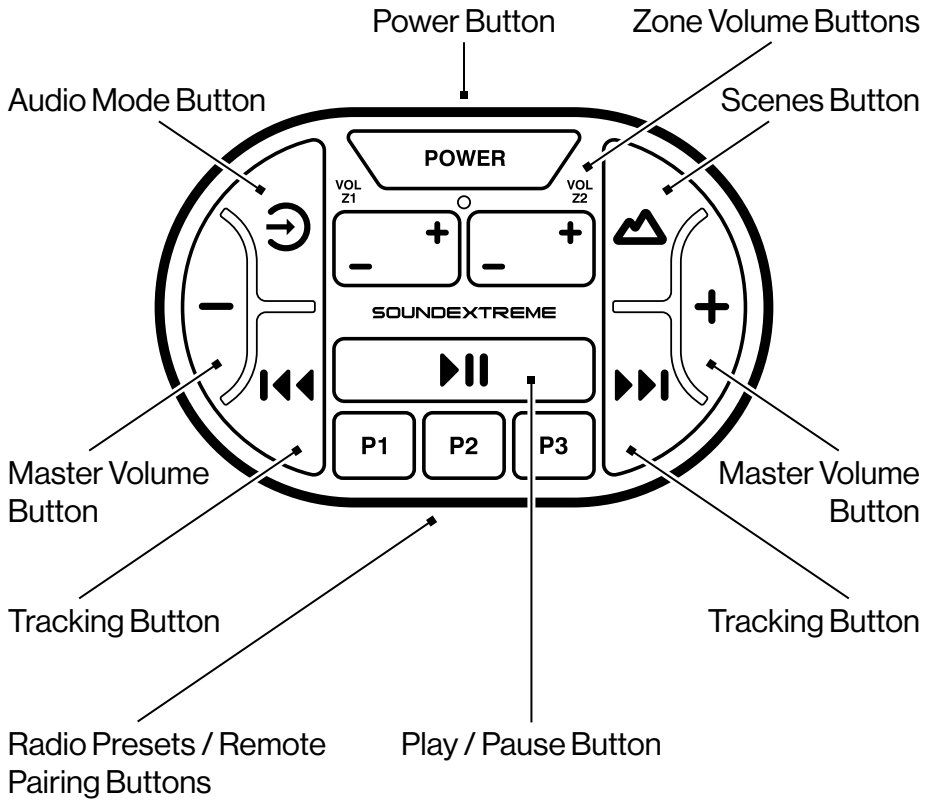

Transom Remote Control Overview

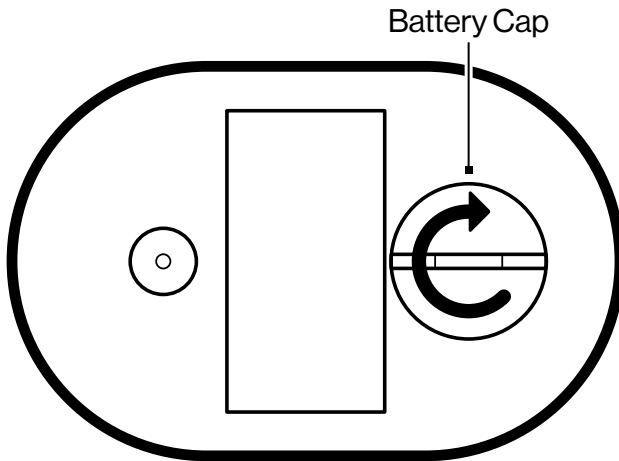

IMPORTANT: Maintaining Waterproofness



Your Bluetooth Remote is only waterproof when the Battery Door is properly closed. In order to properly close the cap, turn it clockwise, making sure that the cap fits flat and flush along the edges with the back panel. If not properly closed the unit is **NOT** watertight.

WARNING: Keep Battery Out of Reach of Children

Transom Remote Control Overview

BUTTON	ACTION	FUNCTION
POWER	Short-Press	To turn the paired SoundExtreme product on / off.
	Press and Hold (for 3 seconds)	To turn the paired SoundExtreme product's LED lights on / off.
	Short-Press	To cycle through the 5 defined Scenes for all Zones.
	Short-Press	To change Audio Source.
	Press and Hold (for 3 seconds)	To place the Transom Remote Control into RF Pairing Mode.
	Short-Press	To play / pause audio.
	Press and Hold (for 3 seconds)	To activate EcoTalk feature.

Transom Remote Control Overview

NOTES

If the paired SoundExtreme product is powered by a battery, short-pressing this button can turn the product off, but it cannot turn the product back on.

If paired with a SoundExtreme Marine Radio:

- Bring up the Audio Source Menu.
- Use the Tracking Buttons to highlight the Audio Mode you want, then short-press the Play Button to select.

If paired with a different SoundExtreme product:

- Each short-press will cycle through the available Audio Source / Modes on the product (e.g., Bluetooth, EcoCast Transmitting / Receiving, FM, AM, Aux-In, etc.).

While in Bluetooth Mode:

- Accept an incoming call if the paired SoundExtreme product has a microphone.





If paired with a SoundExtreme Marine Radio:

- While in AM/ FM Mode, change the radio's Tuning Mode (Auto, Manual, or Preset).

While in Bluetooth Mode:

- Activate Siri or Hey Google.
- Reject an incoming call if the paired SoundExtreme product has a microphone.

Transom Remote Control Overview

BUTTON	ACTION	FUNCTION
	Short-Press	<ul style="list-style-type: none"> · In Bluetooth Mode: To skip to the previous track. · In AM/ FM Mode: To tune in a previous station.
	Short-Press	<ul style="list-style-type: none"> · In Bluetooth Mode: To skip to the next track. · In AM/ FM Mode: To tune in a station.
	Short-Press	To increase or decrease the volume.
	Press and Hold (for 3 seconds)	To increase or decrease the volume.
Vol Z1 	Short-Press	To increase or decrease the volume in Zone 1, only when paired with a SoundExtreme Marine Radio.
Vol Z2 	Short-Press	To increase or decrease the volume in Zone 2, only when paired with a SoundExtreme Marine Radio.
P1/ P2/ P3	Press and Hold (for 3 seconds)	When in AM/ FM Mode: To save the current station to the corresponding Preset Button.
	Short-Press	When in AM/ FM Mode: To tune to the station saved to the corresponding Preset Button.

Transom Remote Control Overview

NOTES

If paired with a SoundExtreme Marine Radio:

- While in Aux-In Mode, decrease the Aux-In gain.

If paired with a SoundExtreme Marine Radio:

- While in Aux-In Mode, increase the Aux-In gain.

If paired with a SoundExtreme Marine Radio:

- To increase or decrease the Master (Zone 3) Volume.

For SoundExtreme products with only one audio Zone.

Button function not applicable for other SoundExtreme products.

Button function not applicable for other SoundExtreme products.

Refer to **Remote Control Pairing** for more details.

Installation

The Transom Remote Control offers 2 options for you to mount onto your water (boat, etc.) or land (UTV, etc.) vehicle's body:

3M – Double-Sided Tape

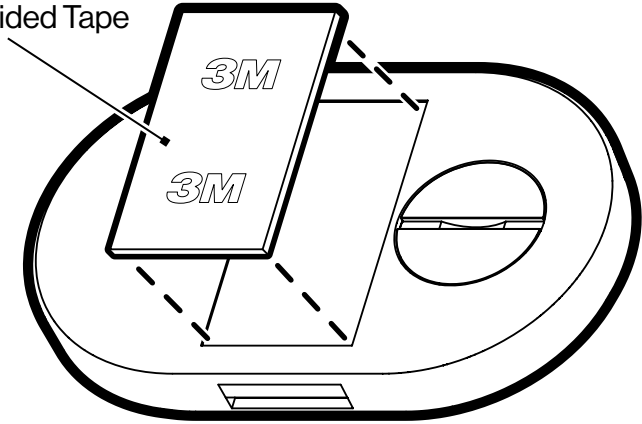

1. Attach the Transom Remote Control directly to a flat surface on your vehicle's body, with the smaller Double-Sided Tape.
2. The Transom Remote Control also includes a Snap-In Holder.

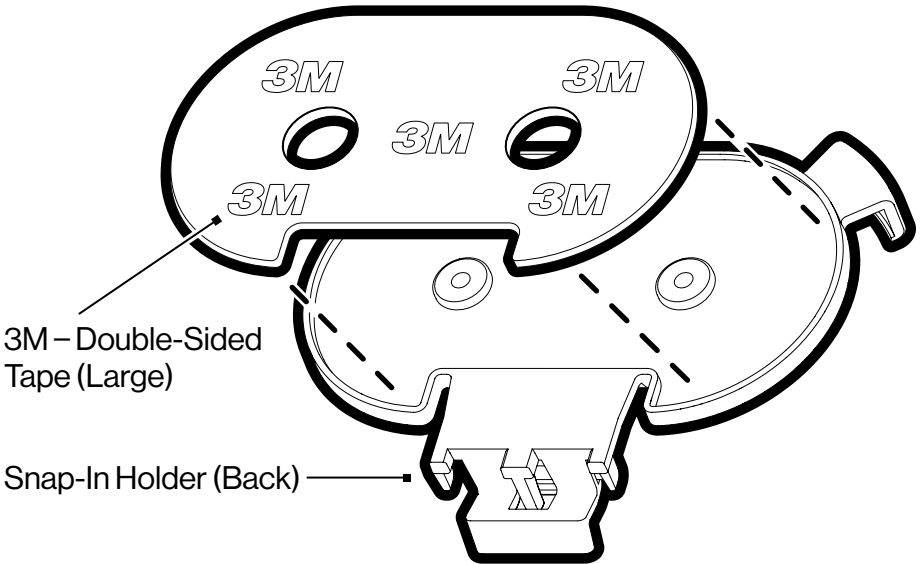

- a. Attach the Snap-In Holder with the larger Double-Sided Tape or,

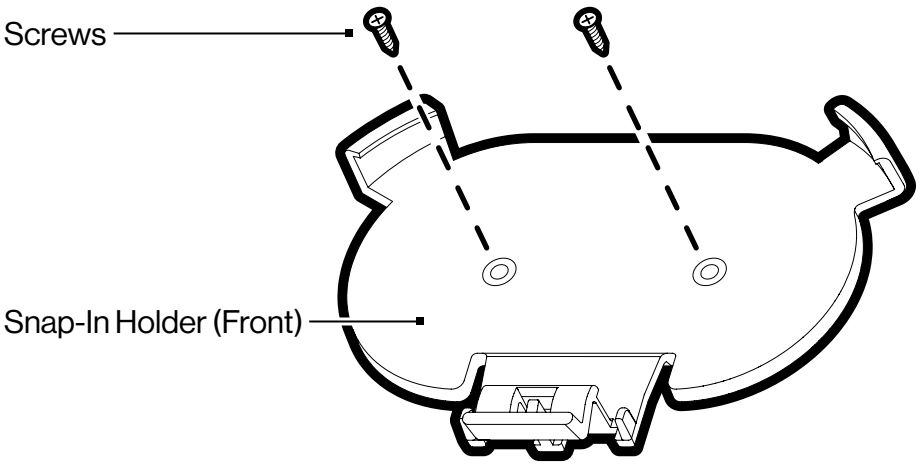

- b. Install the Holder with the two stainless steel Screws to a flat surface on your vehicle's body. (Screws included).

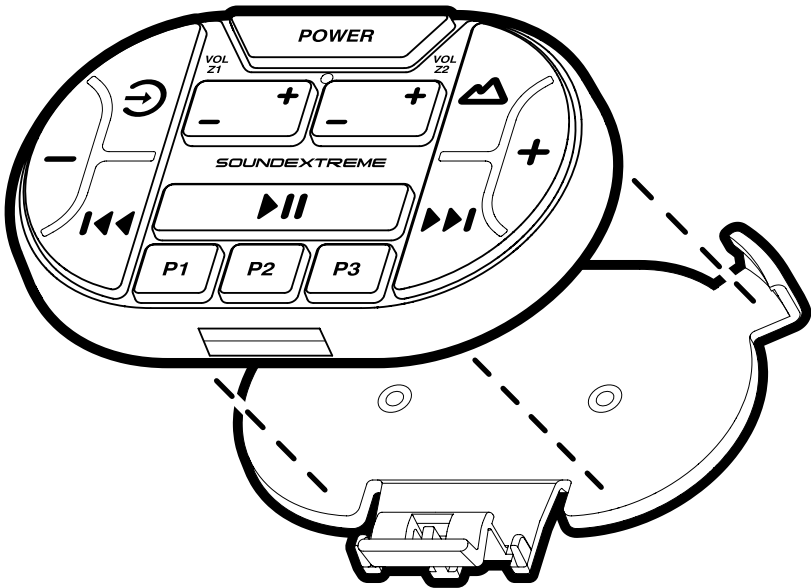

You can now snap in your Transom Remote Control to the holder.

Remote Control Pairing

Remote Control Pairing and Product Selection

The first time you use the Transom Remote Control, you will need to pair it with a SoundExtreme product. Once they are paired, your product will remember your Transom Remote Control. Next time you power on your product, your Transom Remote Control's functions will be ready to use.

The Transom Remote Control can pair with and save up to 3 SoundExtreme products in its memory as P1, P2, and P3.

First Time Remote Control Pairing with a SoundExtreme Product

Before use, pair your Transom Remote Control with a SoundExtreme product as follows:

1. Check if the Transom Remote Control is turned on. You can press any button to see if the LED Status Indicator below the Power Button responds. If not, unscrew the Battery Cap to see if the coin/button battery is well placed, or if the isolator has been removed from the Battery Compartment.

IMPORTANT: If you open the Battery Cap, be sure to properly tighten the cap so that the Battery Compartment is closed and sealed.

2. Turn on the SoundExtreme product you want to pair with the Transom Remote Control. Refer to the SoundExtreme product's User Guide for instructions regarding how to put it into Remote Pairing Mode.

For example, to pair with an amplified Extreme Tower speaker, **press and hold** the **<** and **>** Buttons on the speaker at the same time for 3 seconds. The **L** and **R** LED Status Indicators and the speaker's Party Lights will flash Green, indicating the speaker is ready to pair.

3. On your Transom Remote Control, **press and hold** the Audio Source Button **↻** for 3 seconds, then press P1 (P2 or P3) to save

Remote Control Pairing

the pairing with the SoundExtreme product as P1 (P2 or P3) on the Transom Remote Control.

The **L** and **R** LED Status Indicators on an amplified Extreme Tower speaker and its Party Lights will flash Green 3 times, indicating a successful pairing.

4. You can now press a button on your Transom Remote Control to control the paired product.

Select a SoundExtreme Product to Control

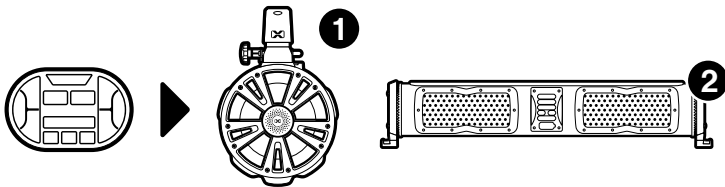

Assuming your Transom Remote Control has paired with **Speaker 1** and **2** as P1 and P2 products, and **Speaker 1** is currently controlled by the Transom Remote Control:

If you want to use the Transom Remote Control to control **Speaker 2**, follow the steps below.

1. **Press and hold** the Audio Source Button  for 3 seconds. **Speaker 1**'s Party Lights will flash Blue, indicating your Transom Remote Control is in the process of speaker selection.
2. While **Speaker 1** is flashing Blue, press P2. The Party Lights on **Speaker 2** will flash Blue 3 times and produce a prompt double-beep tone, indicating **Speaker 2** is selected.
3. The Transom Remote Control will now control **Speaker 2**, while **Speaker 1** will have no response.

Specifications

Unit Dimensions

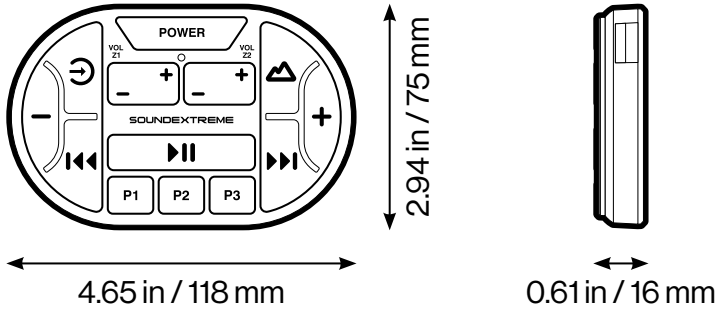

Unit + Holder Dimensions

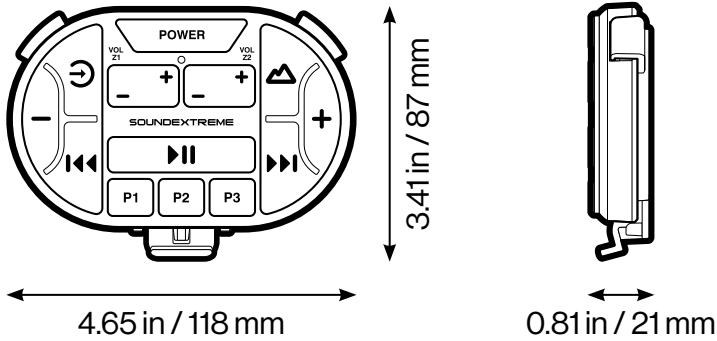

Unit Weight

3.03 oz (86 g)

Unit + Holder Weight

3.88 oz (110 g)

Power Supply

CR2032 coin/button
battery, 3.0V

Remote Frequency

RF 433.92 MHz

Storage Temperature

-40°F to 122°F / -40°C to 50°C

Operating Temperature

23°F to 95°F / -5°C to 35°C

Waterproof / Dustproof Rating

IP67

FCC STATEMENT:

This device complies with Part 15 of the FCC Rules. Operation is subject to the following two conditions:

- 1.) This device may not cause harmful interference, and
- 2.) This device must accept any interference received, including interference that may cause undesired operation.

WARNING: Changes or modifications not expressly approved by the party responsible for compliance could void the user's authority to operate the equipment.

NOTE: FCC's RF Exposure guidelines, this equipment should be installed and operated with minimum distance between 20cm the radiator to your body.

This equipment has been tested and found to comply with the limits for a Class B digital device, pursuant to Part 15 of the FCC Rules. These limits are designed to provide reasonable protection against harmful interference in a residential installation. This equipment generates, uses, and can radiate radio frequency energy and, if not installed and used in accordance with the instructions, may cause harmful interference to radio communications. However, there is no guarantee that interference will not occur in a particular installation. If this equipment does cause harmful interference to radio or television reception, which can be determined by turning the equipment off and on, the user is encouraged to try to correct the interference by one or more of the following measures: reorient or relocate the receiving antenna, increase the separation between the equipment and receiver, connect the equipment into an outlet on a circuit different from that to which the receiver is connected, consult the dealer or an experienced radio/TV technician for help.

RF WARNING STATEMENT:

The device has been evaluated to meet general RF exposure requirement. The device can be used in portable exposure condition without restriction.

IC STATEMENT:

This device complies with Industry Canada licence-exempt RSS standard(s). Operation is subject to the following two conditions:

- 1.) This device may not cause interference, and
- 2.) This device must accept any interference, including interference that may cause undesired operation of the device.

PRODUCT USE AND PROTECTION:

Read and follow all instructions. Use only as intended.

The SoundExtreme unit is intended to be used indoors or outdoors and in land or water environments. The unit has been tested to IP66 waterproofing standards, which means the unit can be exposed to dust and water, but should **NOT** be submerged underwater.

To prevent fire or shock, do **NOT** attempt to power this unit if it is wet or you suspect water has entered the unit. In this situation, please return the unit to SoundExtreme for a free assessment. If we have found that the unit has carried water, we will repair or replace the unit free of charge.

SAFETY ADVISORY & WARNING:

Read and follow all instructions. Use only as intended.

CAUTION: Do **NOT** open to repair. A qualified technician must carry out repair work.

ATTENTION: Do **NOT** connect to a SoundExtreme product with LEDCast technology while the unit is wet. Make sure all connections are dry **BEFORE** connecting to a power source. Failure to do so may result in electrical damage to the unit and may void the warranty.

⚠ WARNING: Cancer and Reproductive Harm - www.P65Warnings.ca.gov

ATTENTION: Do **NOT** dispose of in a landfill. Contact SoundExtreme at www.gracesupport.com or a certified recycling agent to dispose of the unit.

SAFETY:

This product has a limited life span of use and should be replaced when it shows obvious signs of wear.

Do not modify or remove any original component parts of the speaker. Doing so could cause damage to the unit, allowing water to ingress. A unit with water ingress should not be charged due to potential risk of fire or shock.

Please exercise care and good judgment when using your SoundExtreme unit.

You should always

- 1.) Return the unit to SoundExtreme if you suspect water ingress into the unit or if the unit has experienced a severe impact that may have affected the integrity of the unit to take on water.

Important Legal Information

You should never

- 1.) Never power your SoundExtreme unit if you suspect water has entered the device. Powering a device with water inside could be potentially hazardous and cause fire or a spark.
- 2.) Never use your SoundExtreme unit if you have dropped it or thrown it against a hard surface which may have destroyed the integrity of the housing. In the event of a severe impact to your unit, please return the unit to SoundExtreme to review for potential damage.
- 3.) Never attempt to fix, repair your SoundExtreme unit. Please send it back to SoundExtreme for any assessments and repairs.

CARE, MAINTENANCE & PRECAUTIONS:

- 1.) Do **NOT** apply excessive force to any surfaces of the unit.
- 2.) Do **NOT** use or store the unit in places with high temperature.
- 3.) **AVOID** prolonged exposure to strong magnetic fields.

LIMITED MANUFACTURER'S WARRANTY:

The Transom Remote Control is covered by a 1-year limited warranty that covers defects in workmanship and / or materials for a period of 1 year from original purchase date. This warranty does not apply to any products which have been abused, neglected, modified or used for a purpose other than the one for which they were manufactured. Please refer to the above care and maintenance instructions for suggested care details. The warranty is valid only for the original owner who purchases the unit from an authorized dealer. Transfers do not qualify for warranty protection. SoundExtreme reserves the right to replace any out-of-stock or discontinued product with a comparable product. Discontinued products may not be available for warranty replacement. Any contents are **NOT** covered by the limited manufacturer's warranty. Warranty terms may be revised without notification at the discretion of the manufacturer. Please visit www.soundextreme.com for additional product & warranty information.



Transom Remote Control by SoundExtreme Inc., Houston, Texas.
Designed in Texas. Made in China.



soundextreme.com

EXTREME INNOVATION
for YOUR LIFESTYLE

What's in the Box

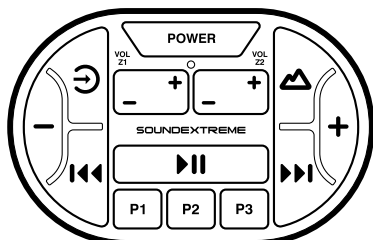

Transom Remote Control

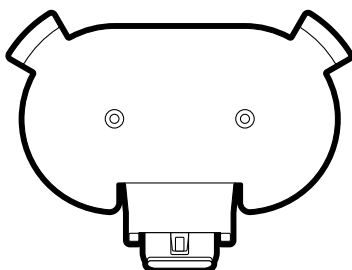

Snap-In Holder

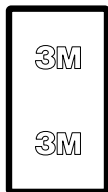

3M Double-Sided Tape
(Smaller)

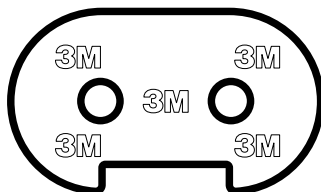

3M Double-Sided Tape
(Larger)



(2x) Stainless Steel Screws

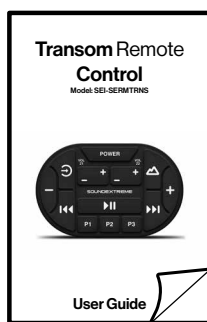

User Guide