

Bluetooth Receiver Remote Control

Model: SEI-SERXBT



User Guide

Important

- Please read this User Guide before installation and use.
- **CAUTION:** The power input voltage range for your Bluetooth® Receiver Remote Control (referred to as Receiver) is 9V to 16V. It is designed to work with a +12V DC battery power supply. If your vehicle battery power output is not 12V (e.g., 24V, 36V, or 48V), you will need a voltage converter with 12V output (e.g., a 48V-to-12V converter). Connecting the Receiver directly to higher voltages will cause damage to your device and **VOID THE PRODUCT WARRANTY.**
- The Receiver has a Remote Turn-On Input feature; this is an optional connection to your vehicle ignition switch so you can turn the Receiver on or off via the ignition switch. When this input has a signal between 12V to 56V, the Receiver will turn on. When there is no input voltage, the Receiver will turn off.
- The Receiver's audio outputs are pre-amplified signals that need to be connected to a power amplifier, radio, or powered speakers (sold separately).
- The Receiver fits in a standard Carling rocker switch opening, which is commonly used in the dashboard of many off-road vehicles, boats, and golf cars. The Receiver panel is waterproof; however, the housing behind the panel is only splash proof.
- **CAUTION:** In order to make sure there is no potential damage to your audio system, unplug or power off your audio equipment until after all connections are completed.

Features

The Receiver is an all-in-one device that supports Bluetooth, EcoCast, and Aux-In.

Bluetooth

The Receiver utilizes Bluetooth 5.1, which provides up to 100 foot Bluetooth range and dual simultaneous smartphone connections.

EcoCast

The Receiver also has EcoCast built-in, which allows the Receiver to broadcast (transmit) or receive audio streams to/from other EcoCast-enabled products. ECOXGEAR and SoundExtreme have a complete line of EcoCast-enabled speakers, soundbars, subwoofers, and radios.

If you currently do not have any other EcoCast-enabled product to work with the Receiver, you can skip all EcoCast-related content.

All EcoCast-enabled products have two optional streaming modes:

- EcoCast Transmitting Mode. When set in this mode, the EcoCast-enabled product transmits either Aux-In or Bluetooth Audio to multiple wirelessly connected EcoCast-enabled products.
- EcoCast Receiving Mode. When set in this mode, this Receiver product receives audio from another EcoCast transmitting audio product, like a SoundExtreme soundbar, radio, or tower speaker.

Receiver Audio Modes

The Receiver has the following 4 Audio Modes: Speaker (Bluetooth) Mode, EcoCast Transmitting Mode, EcoCast Receiving Mode, and Aux-In Mode. Refer to the following table for details.

Introduction

RECEIVER AUDIO MODE	CONNECTED TO PHONE	ECOCAST
Speaker (Bluetooth)	Yes	Disabled
EcoCast Transmitting	Yes	Transmitting
EcoCast Receiving	No	Receiving
Aux-In	No	Disabled or Enabled (Transmitting)

AUDIO INPUT TO RECEIVER

The Receiver is connected to a phone's Bluetooth signal.

The Receiver is connected to a phone's Bluetooth signal.

The Receiver receives audio streams from a wirelessly connected EcoCast-enabled product in Transmitting Mode.

The Receiver receives audio from an Aux-In audio source.

AUDIO OUTPUT TO AMPLIFIER

Audio Output via the RCA cables that are connected to an amplifier, radio, soundbar, etc.

Audio Output via the RCA cables that are connected to an amplifier, radio, soundbar, etc., as well as sending audio wirelessly to other EcoCast-enabled products.

Audio Output via the RCA cables that are connected to an amplifier, radio, soundbar, etc.

Audio Output via the RCA cables that are connected to an amplifier, radio, soundbar, etc. If enabled (Transmitting), it also broadcasts the Aux-In Audio to multiple wirelessly connected EcoCast-enabled products.

Receiver Overview

Receiver Layout

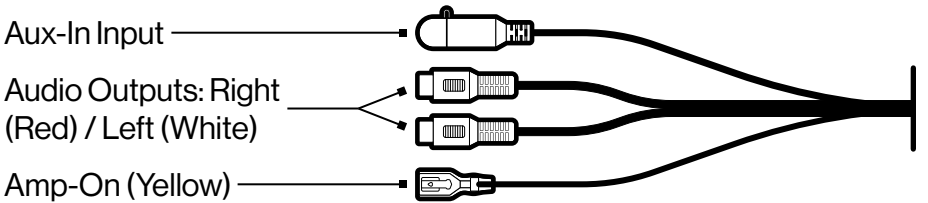
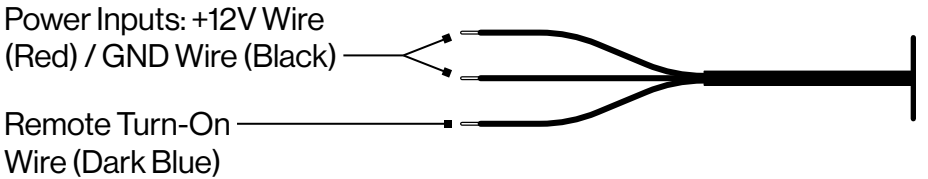
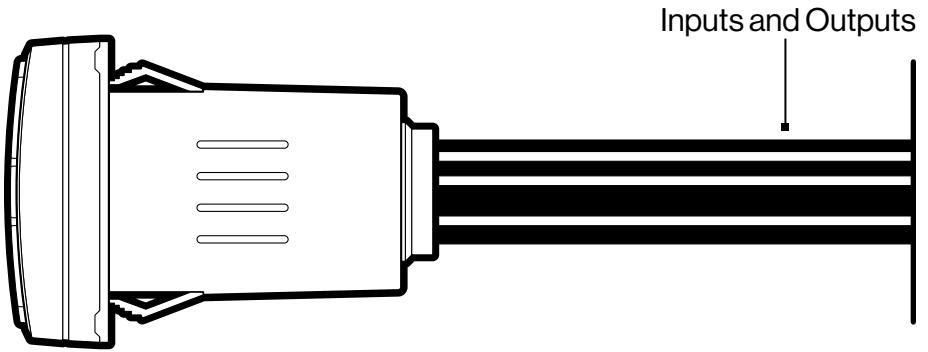
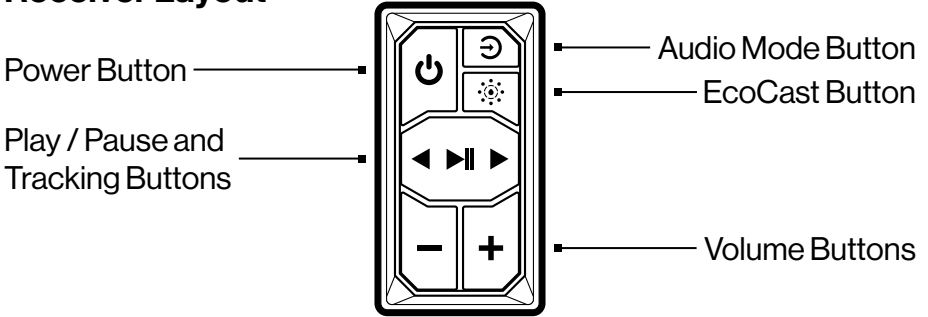

Connectors

Inputs:

- Power +12V, GND
- Remote Turn-On (input signal: 12 - 56V) – When this input is connected to your vehicle's ignition switch (or rocker switch or any switch accessory panel), it will turn on or off without having to press the Power Button .
- Aux In – 3.5mm audio jack. This input can be used to connect an additional soundbar, or other audio source, like your phone, CD player, MP3 player, etc.

Outputs:

- Amp-On – With this output, you can turn on the audio power amplifier the Receiver is connected to.
- RCA Aux-Out – This is the audio output. The Red and White RCA Jacks are the Right and Left audio channels, respectively. Connect the device to an audio power amplifier with RCA to RCA cables (not included) or RCA to 3.5mm audio cables (not included).

Buttons and LED Status Indicators

On / Off

The Receiver can be turned on and off by the following methods:

- If you connect the Remote Turn-On Input to your vehicle's ignition switch or a switch accessory panel, you can turn it on or off by turning the ignition switch on or off.
- If you leave the Remote Turn-On Input unconnected, **press and hold** the Power Button  to turn the Receiver on or off.

Backlit Buttons



When the Receiver is on, all the backlit buttons on the Receiver can be turned on or turned off by short-pressing the Power Button .

Receiver Overview



Mute

- When the Receiver is playing music, double-click the Power Button  to mute or unmute your audio.
- When the Receiver is muted, short-press any button to unmute.



Enable Bluetooth and EcoCast Pairing

- Short-press EcoCast Button  to enable EcoCast pairing.
- **Press and hold** the EcoCast Button  to enable Bluetooth pairing. The Receiver will announce, “Ready to connect.” If the Receiver has already connected to a phone, **press and hold** the EcoCast Button  to disconnect the connected phone and enable pairing to a new phone.
- Press ◀ and ▶ at the same time to clear Bluetooth pairing records.

LED Status Indicator and Voice Prompts

There is a LED Status Indicator behind the Power Button  and the Audio Mode Button . The LEDs correspond to different functions:

i. Speaker (Bluetooth) Audio Mode

- When the Audio Mode is switched to Bluetooth Mode, the Receiver will announce, “Speaker Mode. Ready to connect.” The LED Status Indicator behind the Audio Mode Button  will shine solid Blue, indicating the Audio Source is set to Bluetooth. The LED Status Indicator behind the Power Button  will flash Blue, indicating that Bluetooth pairing has been enabled.
- Once the Receiver has successfully connected to a phone, it will announce, “Your Phone is Connected.” The LED Status Indicator behind the Power Button  will shine solid Blue.

ii. EcoCast Audio Mode

- When the Audio Mode is switched to EcoCast Transmitting Mode, the Receiver will announce, “EcoCast Transmitting.” The LED

Status Indicator behind the Audio Mode Button  will flash Red, indicating EcoCast pairing has been enabled.



- When the Audio Source is switched to EcoCast Receiving Mode, the Receiver will announce, "EcoCast Receiving". The Status LED behind the Audio Mode Button  will flash Green, indicating EcoCast pairing has been enabled. Once the Receiver is paired and connected to a speaker in EcoCast Transmitting mode, it will announce, "Connection successful." The Status LED will shine solid Green.

iii. Aux-In Audio Mode

- When the Audio Source is switched to Aux-In Audio Mode, the Receiver will announce, "Aux-In." The Status LED behind the Audio Mode Button  will shine solid Yellow.

The following table lists all the Button functions with related Status LED indications and voice prompts.







Receiver Overview

BUTTON	ACTION	FUNCTION
	Press and Hold (for 3 seconds)	To turn on / off the Receiver.
	Short-Press	To turn on / off the Backlit Buttons.
	Double-Click	To mute / unmute audio.
	Short-Press	To cycle through each of the four Audio Source Modes.

Receiver Overview

LED STATUS INDICATOR	VOICE PROMPT
<ul style="list-style-type: none">· On: The Receiver is connected to a phone.· Off: No LED.	N/A
N/A	N/A
N/A	N/A
Bluetooth Audio Mode <ul style="list-style-type: none">· Solid Blue – Bluetooth Mode.	<ul style="list-style-type: none">· "Speaker Mode. Ready to connect."· "Your phone is connected."
Power Button LED Status Indicator <ul style="list-style-type: none">· Flashing Blue – Pairing ready.· Solid Blue – Pairing successful.	
EcoCast Transmitting Audio Mode <ul style="list-style-type: none">· Flashing Red – Pairing ready.· Solid Red – Pairing not enabled.	<ul style="list-style-type: none">· "EcoCast Transmitting."
EcoCast Receiving Audio Mode <ul style="list-style-type: none">· Flashing Green – Pairing ready.· Solid Green – Pairing successful.	<ul style="list-style-type: none">· "EcoCast Receiving."· "Connection successful."
Aux-In Audio Mode <ul style="list-style-type: none">· Flashing Yellow – EcoCast Transmitting, pairing ready.· Solid Yellow – Aux-In Audio Mode enabled.	<ul style="list-style-type: none">· "Aux-In."· "EcoCast enabled."· "EcoCast disabled."

Receiver Overview

BUTTON	ACTION	FUNCTION
	Short-Press	EcoCast Pairing.
	Press and Hold (for 3 seconds)	Bluetooth Pairing.
	Short-Press	Play or pause.
	Short-Press	Skip to next track.
	Short-Press	Skip to previous track.
	Short-Press	Increase volume.
	Press and Hold (for 3 seconds)	Increase volume continuously.
	Short-Press	Decrease volume.
	Press and Hold (for 3 seconds)	Decrease volume continuously.

Receiver Overview

LED STATUS INDICATOR

VOICE PROMPT

- Flashing Red, Green, or Yellow, depending on the Audio Mode.

N/A

- Flashing Blue.

- "Ready to connect."

N/A

N/A

N/A

N/A

N/A

N/A

N/A

N/A

N/A

N/A

N/A

N/A

N/A

N/A

Installation and Wiring

Installing Your Receiver Onto Your Vehicle

The Receiver is designed to snap into a standard Carling style rocker switch opening.

- If you already have that style of an opening on your vehicle, you can simply snap the Receiver into place.
- If your vehicle doesn't already have that style of an opening, you will need to cut a rectangular hole into your vehicle. Before you cut, please refer to the dimensions under the Specifications section to determine the cutout size.

Connecting to 12VDC Power Supply

The Receiver does not have an internal battery. It must be connected to an external 12VDC power supply to function. When you install the Receiver to a battery or a voltage regulator on a golf cart, a boat, a quad bike, a UTV, or another vehicle, you need to make sure that your vehicle battery or battery pack terminal voltage is 12VDC. If the battery terminal voltage is not 12V, you will need a DC-DC converter with output 12V. Connecting the Receiver to a non-12VDC power source will lead to a malfunction or damage to the Receiver.

Recommendation: If you are not familiar with all of the vehicle's battery or ignition switch connections, consult your vehicle's manual or a technician. Incorrect connections to your vehicle's battery or ignition signal terminal may cause damage to your speaker and your vehicle.

Connect the +12V and GND wires to the 12VDC power supply.

- Make sure that the **RED** Wire is connected to +12V battery's positive (+) terminal and the **BLACK** Wire is connected to battery's negative (-) terminal.

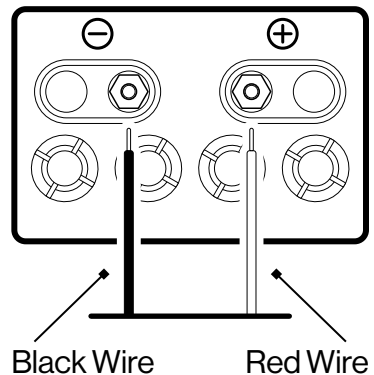

WARNING! Only connect to a 12V power supply. Do **NOT** connect to a 24V, 36V, or 48V power supply. Connecting the Receiver directly to these higher voltages will cause damage to the Receiver and **VOID THE PRODUCT WARRANTY.**

Connecting the Remote Turn-On Input Wire to a Switch

Besides the 12V power supply, the Receiver has an optional Remote Turn-On Signal Input to turn on and power off via your vehicle's ignition switch. The input voltage range to turn on is 12V to 56V. When the input voltage is 0, it will power off the receiver.

You will need to connect the (Dark Blue) Remote Turn-On Wire to the vehicle ignition switch with an extension cable (not included). If you are not able to connect it to your vehicle's ignition switch, connect this input to a rocker switch (not included), then connect the rocker switch to a 12V to 56V power supply on your vehicle or to a switch accessory panel.

Connecting to a Switch

To connect the Receiver to your vehicle's ignition switch, a rocker switch, or the vehicles switched power distribution panel, follow the steps below:

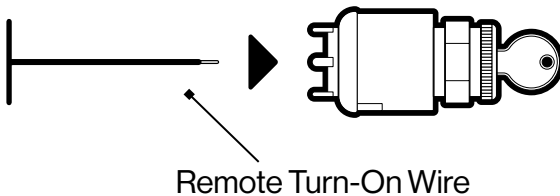

1. Connect the (Dark Blue) Remote Turn-On Wire to the Accessories terminal of your switch with an extension cable.
2. Once the connections are completed, the Receiver will turn on or off when the switch is turned on or off.

Installation and Wiring

Connecting Your Audio Output

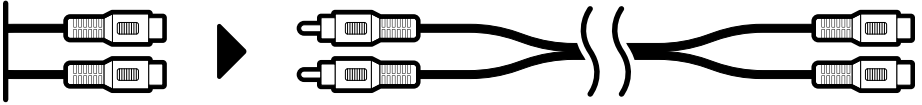



1. Connect the audio output to the audio power amplifier inputs with an RCA to RCA cable (not included) or an RCA to 3.5mm audio cable (not included).

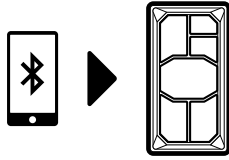

2. Connect the AMP-On Wire (Yellow) to the Remote-Control input on the audio power amplifier. This feature will turn your amplifier on when the Receiver is turned on.

First Time Pairing in Speaker (Bluetooth) Mode



1. Press and hold the Power Button  to turn on the Receiver. If the Receiver is in Speaker (Bluetooth) Mode, it will announce, "Speaker Mode. Ready to connect," and the LED Status Indicator behind the Power Button will flash Blue.
 - If you do not hear this voice prompt, you can switch the Audio Mode to Speaker Mode by short-pressing the Audio Mode Button  to cycle through the Audio Modes.
2. Refer to your phone's Bluetooth settings. Search for and select '**SoundEX-Rocker**' to pair and connect.
3. Once paired and connected to your phone, the Receiver will announce, "Your phone is connected," and the LED Status Indicator behind the Power Button will shine solid Blue.

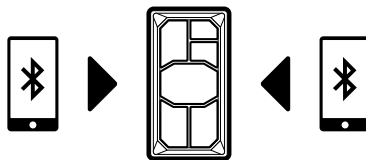

Dual Simultaneous Connections and Switching Media Player Between Two Phones



Your Receiver can maintain simultaneous connections with two smartphones, which allows you and your family or friends to share music by switching the music playback between your phone and

Audio Functions

your family member or friend's phone. Follow the steps outlined below to switch back and forth between two phones:

1. Connect your phone to the Receiver.
2. **Press and hold** the EcoCast Button  for 3 seconds. This will disconnect your phone and enable Bluetooth pairing. Connect a second phone to the Receiver.
3. **Press and hold** the Power Button  to turn off the Receiver. Then **press and hold** the button again to turn it on.
4. Your Receiver will automatically reconnect to both phones.
5. On the first phone, play a selected music track on your phone. Your Receiver will play your music.
6. On the second phone, select music to play. Your Receiver will play the music from the second phone. The music on the first phone will pause or stop.
7. If you want to switch back to your phone, press the play button on your phone's media player. Your Receiver will play the music on your phone. The media player on the second phone will pause or stop.
8. You can now switch back and forth between the two phones.

EcoCast – Stream Music Between Multiple Speakers

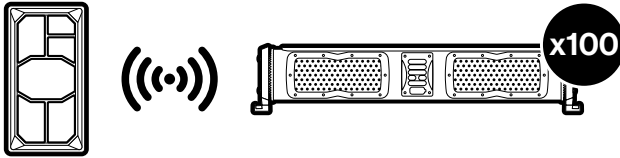

The Receiver has EcoCast built-in, which allows it to broadcast (transmit) or receive wireless audio streams to or from other EcoCast-enabled products.

EcoCast: First Time Pairing in EcoCast Mode

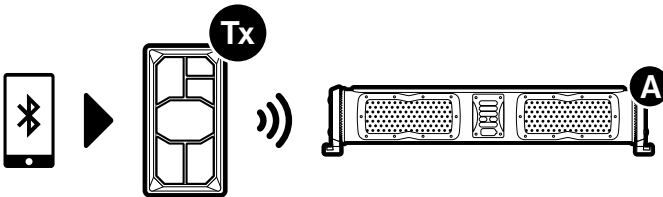

Like the Bluetooth pairing between the Receiver and your phone, there is an EcoCast pairing process. To enable EcoCast pairing, follow the steps below:

1. Turn on the Receiver (**Tx**) and put it into Speaker Mode. Connect to your phone and play your desired audio.
2. Press the Audio Mode Button  to switch the Receiver to EcoCast Transmitting Mode. The LED Status Indicator will flash Red, and the speaker will announce, “EcoCast transmitting.”
3. Turn on an EcoCast-enabled product (e.g. an SE28 soundbar, **Speaker A**) and put it into EcoCast Receiving Mode. The LED Status Indicator will flash Green, and the speaker will announce, “EcoCast receiving.”

Audio Functions

- Once the connection between the products is successful, **Speaker A** will announce, “Connection successful,” and start playing music.

EcoCast: Additional Receiving Speakers

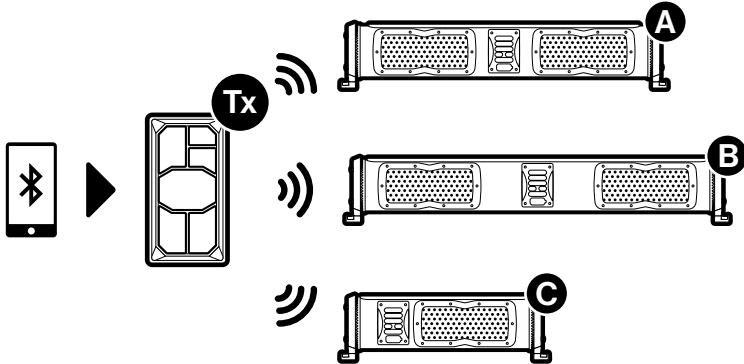

To add additional EcoCast-enabled products, follow the steps below:

- Turn on additional EcoCast-enabled products (**Speaker B** and **Speaker C**) and put them into EcoCast Receiving Mode. The LED Status Indicator will flash Green, and the product will announce, “EcoCast receiving.”
- On the Receiver, press the EcoCast Button . The LED Status Indicator will flash Red.
- Once the connection between the products is successful, **Speaker B** (and **Speaker C**) will announce, “Connection successful,” and start playing audio.

Notes:

- If all the products are turned off, then turned on, the product(s) in EcoCast Receiving Mode (**Speakers A, B, and C**) will automatically reconnect to the product in EcoCast Transmitting Mode (the



Receiver). If they do not automatically reconnect, please follow the above steps to reconnect.

- The EcoCast functionality has a maximum range of 30 feet between products.
- While connecting the speakers, make sure that they are within a few feet of each other.

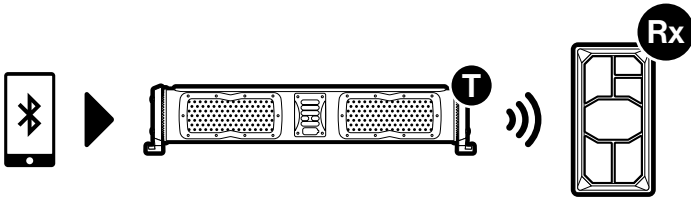
EcoCast: Play Audio Streams From Another Speaker



If there is an EcoCast-enabled product in EcoCast Transmitting Mode and playing music nearby, you can set your Receiver (**Rx**) to receive and play audio streams from the EcoCast Transmitting product (**Speaker T**). Follow the steps below:

1. Turn on your Receiver and press the Audio Mode Button  to cycle through to EcoCast Receiving Mode. The LED Status Indicator will flash Green, and the Receiver will announce, "EcoCast receiving."
2. On **Speaker T**, **press and hold** the EcoCast Button  for 3 seconds. The LED Status Indicator will flash Red.

Note: If **Speaker T** is not a SoundExtreme Elite soundbar, it may require a different button operation to enter EcoCast Transmitting (Pairing Ready) Mode. Please refer to **Speaker T's** User Guide.

3. Once the connection between the Receiver and the speaker is successful, your Receiver will announce, "Connection successful," and start playing audio.

Audio Functions

Note: Your Receiver in EcoCast Receiving Mode will play at the same volume level (Volume Sync) as received in the audio streams from the EcoCast Transmitting product. You can press **+** or **-** on the Receiver to adjust the volume for its Audio Outputs only. However, as soon as the EcoCast Transmitting product has a playback change (e.g., track change or a volume change), the Receiver will once again Volume Sync with the Transmitting speaker.

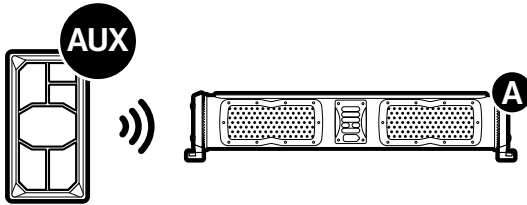

EcoCast: Streaming Your Aux-In Audio to Multiple Speakers



The Receiver also has the capability to stream Aux-In Audio to other EcoCast-enabled products in Receiving Mode.

Each time the Audio Source is switched to Aux-In Audio Mode, the Receiver automatically disables EcoCast. To enable EcoCast Transmitting, press the **-** and  Buttons at the same time. The Receiver will announce, "EcoCast enabled."

To transmit Aux-In Audio streaming via EcoCast, follow the steps below:

1. Turn on another EcoCast-enabled product (**Speaker A**). Press the Audio Mode Button  to cycle through to EcoCast Receiving Mode. The Status LED Indicator will flash Green, and **Speaker A** will announce, "EcoCast receiving."
2. On the Receiver, press the EcoCast Button . The LED Status Indicator will flash Yellow.

3. Once the connection between the products is successful, **Speaker A** will announce, "Connection successful," and start playing your Aux-In audio.

If you wish to disable EcoCast Transmitting again while in Aux-In Audio Mode, you can press the **—** and  Buttons at the same time. The Receiver will announce, "EcoCast disabled."

Specifications

Dimensions

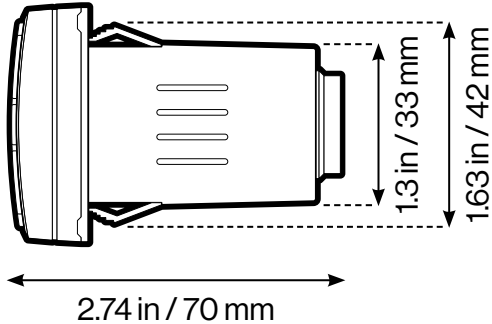
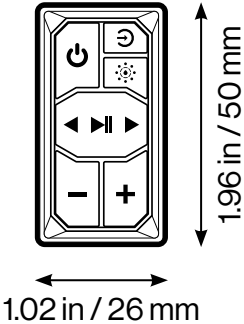
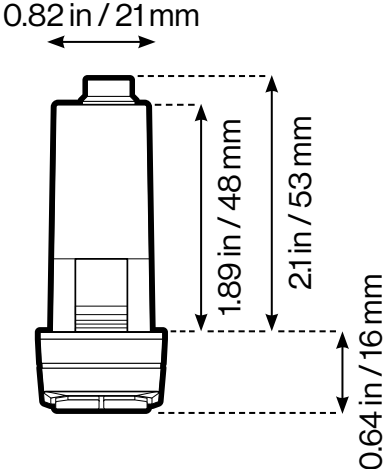

Unit Weight

3.88 oz (110 g)

Power Input

9~16V, 1A

Remote Turn-on Input

9~56V, 1A

AMP-On Output

9~16V, $1 \leq 12$ mA

Bluetooth Frequency Band

2.402~2.480GHz ISM Spectrum

Bluetooth Compliance

Bluetooth® 5.1

EcoCast Range

30 ft / 9.1 m between Casting
speaker and the Receiver

Storage Temperature

-40°F to 122°F / -40°C to 50°C

Operating Temperature

23°F to 95°F / -5°C to 35°C

Important Legal Information

FCC STATEMENT:

This device complies with Part 15 of the FCC Rules. Operation is subject to the following two conditions:

- 1.) This device may not cause harmful interference, and
- 2.) This device must accept any interference received, including interference that may cause undesired operation.

WARNING: Changes or modifications not expressly approved by the party responsible for compliance could void the user's authority to operate the equipment.

NOTE: FCC's RF Exposure guidelines, this equipment should be installed and operated with minimum distance between 20cm the radiator to your body.

This equipment has been tested and found to comply with the limits for a Class B digital device, pursuant to Part 15 of the FCC Rules. These limits are designed to provide reasonable protection against harmful interference in a residential installation. This equipment generates, uses, and can radiate radio frequency energy and, if not installed and used in accordance with the instructions, may cause harmful interference to radio communications. However, there is no guarantee that interference will not occur in a particular installation. If this equipment does cause harmful interference to radio or television reception, which can be determined by turning the equipment off and on, the user is encouraged to try to correct the interference by one or more of the following measures: reorient or relocate the receiving antenna, increase the separation between the equipment and receiver, connect the equipment into an outlet on a circuit different from that to which the receiver is connected, consult the dealer or an experienced radio/TV technician for help.

RF WARNING STATEMENT:

The device has been evaluated to meet general RF exposure requirement. The device can be used in portable exposure condition without restriction.

IC STATEMENT:

This device complies with Industry Canada licence-exempt RSS standard(s). Operation is subject to the following two conditions:

- 1.) This device may not cause interference, and
- 2.) This device must accept any interference, including interference that may cause undesired operation of the device.

PRODUCT USE AND PROTECTION:

Read and follow all instructions. Use only as intended.

The SoundExtreme unit is intended to be used indoors or outdoors and in land or water environments. The unit has been tested to IP66 waterproofing standards, which means the unit can be exposed to dust and water, but should **NOT** be submerged underwater.

To prevent fire or shock, do **NOT** attempt to power this unit if it is wet or you suspect water has entered the unit. In this situation, please return the unit to SoundExtreme for a free assessment. If we have found that the unit has carried water, we will repair or replace the unit free of charge.

SAFETY ADVISORY & WARNING:

Read and follow all instructions. Use only as intended.

CAUTION: Do **NOT** open to repair. A qualified technician must carry out repair work.

ATTENTION: Do **NOT** connect to a SoundExtreme product with LEDCast technology while the unit is wet. Make sure all connections are dry **BEFORE** connecting to a power source. Failure to do so may result in electrical damage to the unit and may void the warranty.

⚠ WARNING: Cancer and Reproductive Harm - www.P65Warnings.ca.gov

ATTENTION: Do **NOT** dispose of in a landfill. Contact SoundExtreme at www.gracesupport.com or a certified recycling agent to dispose of the unit.

SAFETY:

This product has a limited life span of use and should be replaced when it shows obvious signs of wear.

Do not modify or remove any original component parts of the speaker. Doing so could cause damage to the unit, allowing water to ingress. A unit with water ingress should not be charged due to potential risk of fire or shock.

Please exercise care and good judgment when using your SoundExtreme unit.

You should always

- 1.) Return the unit to SoundExtreme if you suspect water ingress into the unit or if the unit has experienced a severe impact that may have affected the integrity of the unit to take on water.

Important Legal Information

You should never

- 1.) Never power your SoundExtreme unit if you suspect water has entered the device. Powering a device with water inside could be potentially hazardous and cause fire or a spark.
- 2.) Never use your SoundExtreme unit if you have dropped it or thrown it against a hard surface which may have destroyed the integrity of the housing. In the event of a severe impact to your unit, please return the unit to SoundExtreme to review for potential damage.
- 3.) Never attempt to fix, repair your SoundExtreme unit. Please send it back to SoundExtreme for any assessments and repairs.

CARE, MAINTENANCE & PRECAUTIONS:

- 1.) Do **NOT** apply excessive force to any surfaces of the unit.
- 2.) Do **NOT** use or store the unit in places with high temperature.
- 3.) **AVOID** prolonged exposure to ultraviolet radiation (UV sunlight) and strong magnetic fields.

LIMITED MANUFACTURER'S WARRANTY:

The Receiver is covered by a 1-year limited warranty that covers defects in workmanship and / or materials for a period of 1 year from original purchase date. This warranty does not apply to any products which have been abused, neglected, modified or used for a purpose other than the one for which they were manufactured. Please refer to the above care and maintenance instructions for suggested care details. The warranty is valid only for the original owner who purchases the unit from an authorized dealer. Transfers do not qualify for warranty protection. SoundExtreme reserves the right to replace any out-of-stock or discontinued product with a comparable product. Discontinued products may not be available for warranty replacement. Any contents are **NOT** covered by the limited manufacturer's warranty. Warranty terms may be revised without notification at the discretion of the manufacturer. Please visit www.soundextreme.us for additional product & warranty information.



The Bluetooth® word mark and logos are registered trademarks owned by Bluetooth SIG, Inc. and any use of such marks by ECOXGEAR is under license. Other trademarks and trade names are those of their respective owners.

Bluetooth Receiver Remote Control by SoundExtreme Inc., Houston, Texas.
Designed in Texas. Made in China.

What's in the Box

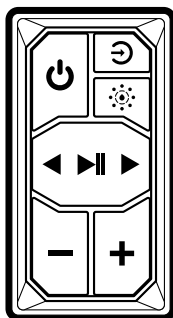

Bluetooth Receiver
Remote Control



User Guide