



# 4 Channel Amplifier

Model: SEI-AMP30041



## User Guide

# Introduction

---

- Please read this User Guide before installation and use.

## Features

The 4 Channel Amplifier (hereafter referred to as Amp) includes the following features.

- Compact marine / powersports HD 4-channel amplifier with 75W RMS @ 4 ohms.
- Perfect for any outdoor vehicle where space is at a premium. The Amp is ideal for UTVs, ATVs, boats, and golf cars.
- Integrating top-of-the-line Texas Instruments High-Definition amplifier integrated circuit.
- Built-in DSP Crossover Frequency controls provide the widest frequency filter adjustments. From 20Hz to 6kHz, 24dB/Octave for high-pass and 55Hz to 6kHz, 24dB/Octave for low-pass.
- 100% waterproof and dirtproof, you can rinse off your Amp with a hose. The die-cast aluminum chassis is sealed to keep all the components free of water, dirt, sand, and salt.
- **Recommendation:** Wiring and hardware not included with amplifier. Purchase 8-gauge power and ground leads.

## Important

- The Amp requires +12V DC voltage for the power input. If your vehicle battery power is not 12V (e.g., 24V, 36V, or 48V), you will need a DC-DC voltage converter with 12V output (e.g. a 48V-to-12V converter). Connecting the Amp directly to higher voltages will cause damage to the amp and **VOID THE PRODUCT WARRANTY.**
- The power input has an in-line 35 amp fuse. Do **NOT** replace the fuse with one of a different value and never bypass the fuse.
- The Amp has a Remote Turn-On Input feature; this is to ensure that the amplifier is completely powered off (no battery consumption) when your vehicle is not in use. When the input has a signal

between 10V and 15V, the amp will turn on. When the input voltage is lower than 10V or there is no input voltage, the amplifier will turn off. In general, this Remote Turn-On Input connects to your audio source's amp-on output.

- The Amp will put an increased load (maximum 30A, 12V) on a vehicle's battery and charging system. We recommend checking your alternator and battery condition to ensure that the electrical system has enough capacity to handle the increased load from your stereo system.
- The Amp's Settings and Controls Panel is located on the right side, behind a cover with a waterproof gasket. Unscrew the left and right screws to remove the cover to change the amplifier's settings. After completing the adjustments, please reinstall the cover back to the panel tightly, ensuring the panel is sealed. Failing to do so will result in potential water or moisture intrusion and damage to the electronics inside.
- **BEFORE** installation, disconnect any and all negative leads from the battery's negative (-) terminal to prevent damage to the unit, fire, and/or possible injury.
- **BEFORE** wiring and connecting the Amp, disconnect the device(s) you are connecting to from their respective power source(s) to ensure no damage is done to the amplifier or audio source devices. Failure to do so could result in permanent damage to the audio system, amplifier, or connected speaker(s).
- If you bridge the Amp, make sure all the wiring is correct. Under no circumstances should the positive and negative Speaker Outputs connect to each other. Doing so will result in a short-circuit.
- **Hearing Damage Warning:** Listening to audio at a high volume for a prolonged period of time can cause damage to your hearing.
- **Recommendation:** If you are not familiar with the vehicle's battery connections, consult your vehicle's manual or a technician. Incorrect connections to your vehicle's battery terminal may cause damage to your speaker and your vehicle.

# 4 Channel Amp Overview

## Amp Layout

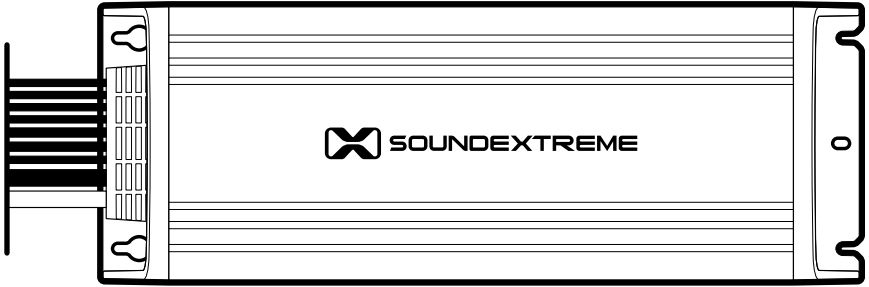

Front

### LED Status Indicator

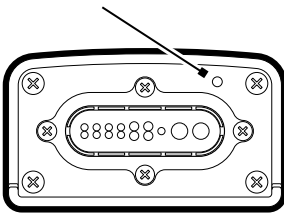

Connectors Panel

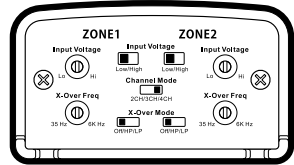

Settings and Controls Panel

# 4 Channel Amp Overview

## 4 Channel Speaker Outputs:

- Zone 2 Right Speaker (+)
- Zone 2 Right Speaker (-)
- Zone 2 Left Speaker (+)
- Zone 2 Left Speaker (-)
- Zone 1 Right Speaker (+)
- Zone 1 Right Speaker (-)
- Zone 1 Left Speaker (+)
- Zone 1 Left Speaker (-)

## 4 Channel Audio Inputs: RCA Aux-In

- Zone 2 Left (White)
- Zone 2 Right (Red)
  
- Zone 1 Left (White)
- Zone 1 Right (Red)

Remote Turn-On Wire (Turquoise)

Ground (GND) Wire (Black)

Power-In (+12V) Wire (Red)

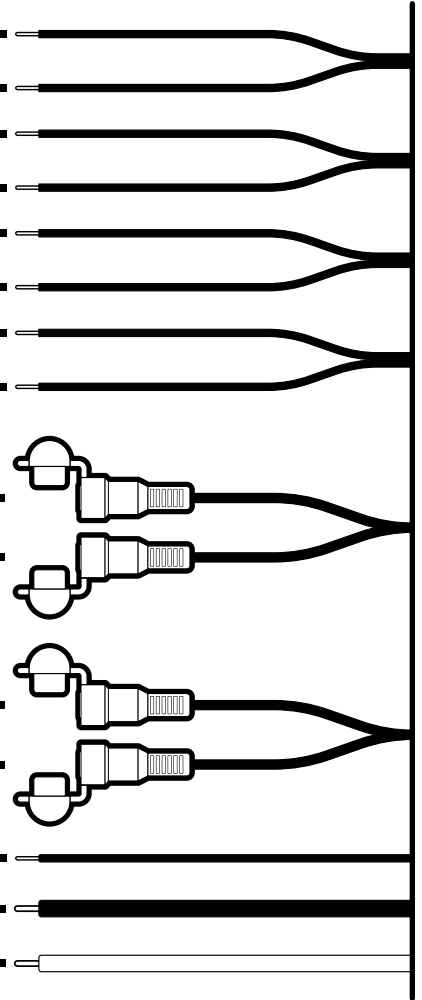

# 4 Channel Amp Overview

---

## Connectors Panel

### LED Status Indicator

- No light: The Amp is powered off.
- Solid Green: The Amp is on and operating normally.
- Flashing Orange and Green: The Amp is in Protected Mode from overcurrent, short-circuit, or overheating. Refer to **Troubleshooting** for more details.

**Note:** The Amp will enter Protected Mode to prevent product failure, shutting down to protect the device's circuitry. When the problem is corrected, the Amp will return to normal operation and the LED Status Indicator should shine solid Green.

- Solid Orange: Contact SoundExtreme customer service for technical support.

### Connectors

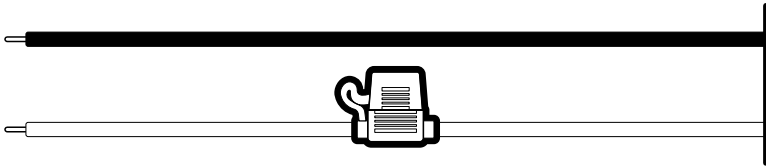

- Power Input: +12V and GND bare wire connectors, with in-line 35 Amp Fuse Holder.
- Remote Turn-On Input: When the input signal is +10V to +15V, the Amp is turned on. When the input signal is lower than +10V, the Amp is turned off.
- 4 Channel Audio Signal Inputs: 2 pairs of stereo RCA connector jacks, set for 2 Zones.
  - Zone 1 – Left (White) and Right (Red)
  - Zone 2 – Left (White) and Right (Red)

## 4 Channel Amp Overview

- 4 Channel Speaker Outputs: 4 pairs of speaker output wires, set for 2 Zones.
  - Zone 1 – Left Speaker Output Wires L- and L+
  - Zone 1 – Right Speaker Output Wires R- and R+
  - Zone 2 – Left Speaker Output Wires L- and L+
  - Zone 2 – Right Speaker Output Wires R- and R+

### Settings and Controls Panel

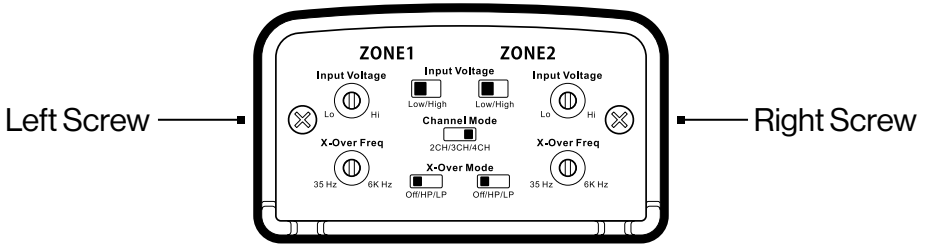

The Amp's Settings and Controls Panel is located on the right side of the unit, behind a waterproof Panel Cover. Unscrew the left and right screws to find and access the switches and dials for changing the amplifier's settings.

**Recommendation:** Use a flathead screwdriver to turn the dials.

The panel has three settings:

1. Channel Mode
2. Input Voltage Signal Range for Zone 1 and 2
3. Crossover Frequency for Zone 1 and 2

**IMPORTANT:** After completing any changes to the settings on the device, be sure to put the Panel Cover back in place and tightly screw

## 4 Channel Amp Overview

---

in the panel to ensure the device is properly sealed. Failing to properly seal your device may result in potential moisture intrusion that may damage the internal electronics.

### Channel Mode Settings

The Channel Mode Switch has 3 positions for different speaker setups and wirings. Refer to **Channel Mode and Bridge** for details.

1. 2CH – 2 Channels
2. 3CH – 3 Channels
3. 4CH – 4 Channels

### Input Signal Voltage Range Settings

Each Zone has the following Input Signal Voltage Range settings.

1. Input Voltage Switch – 2-position switch
  - Low position: RCA/Preamp Level Range (500mV – 3V).
  - High position: RCA/Preamp or Speaker Level Range (3V – 14.5V).
2. Input Voltage Dial: Adjust the input signal for attenuation so that it does not exceed the amplifier signal input limit.
  - Higher Voltage Input: Turn the dial clockwise to decrease the volume.
  - Lower Voltage Input: Turn the dial counterclockwise to increase the volume.

### Crossover Frequency Settings

The Amp has DSP Crossover Frequency controls, providing the widest frequency high-pass and low-pass filter adjustments. Each Zone has the following settings.



### 1. Crossover Frequency Settings

#### a. 3-Position X-Over Mode Switch – Off, High, and Low.

- Off: This allows all frequencies to pass through, no matter the X-Over Freq Dial setting.
- High Pass: This only allows frequencies **ABOVE** the X-Over Freq Dial setting to pass through.
- Low Pass: This only allows frequencies **BELOW** the X-Over Freq Dial setting to pass through.

#### b. X-Over Freq Dial: Adjusts the filter cutoff frequency of the selected X-Over Mode.

- When the X-Over Mode Switch is off, the Dial setting does not apply.
- When the X-Over Mode Switch is set to High, the Dial setting range is 20Hz to 6kHz, 24dB/Octave.
- When the X-Over Mode Switch is set to Low, the Dial setting range is 55Hz to 6kHz, 24dB/Octave.

# Channel Mode and Bridge

The Amp has 4 Channels of amplified Speaker Outputs, which allow you to connect 4 speakers to make a 2-Zone stereo system. If you only have 2 or 3 speakers and want more amplifier power output to one or two speakers, you can Bridge the Amp. The table below lists 3 Speaker Output settings for the Amp.

**Note:** Bridging the Amp requires:

1. Correct Channel Mode Switch setting
2. Proper Audio Signal Input and Speaker Output wirings

**IMPORTANT:** Speaker Output cannot be Bridged across different Zones.

SPEAKER OUTPUT	CHANNEL MODE	BRIDGED INPUT	BRIDGED OUTPUT	AUDIO OUTPUT
4 Speakers	4 Channels	No	No	2 Zones Each in Stereo
3 Speakers	3 Channels	Yes	Yes	1 Zone in Stereo + 1 Zone Bridged in Mono
2 Speakers	2 Channels	Yes	Yes	1 Zone Bridged in Stereo

## 4 Channel Setting

### Channel Mode



2CH/3CH/4CH

The 4 Channel Setting allows you to set up a 2-Zone stereo audio system. As there is no Bridging, wiring is straightforward:

# Channel Mode and Bridge

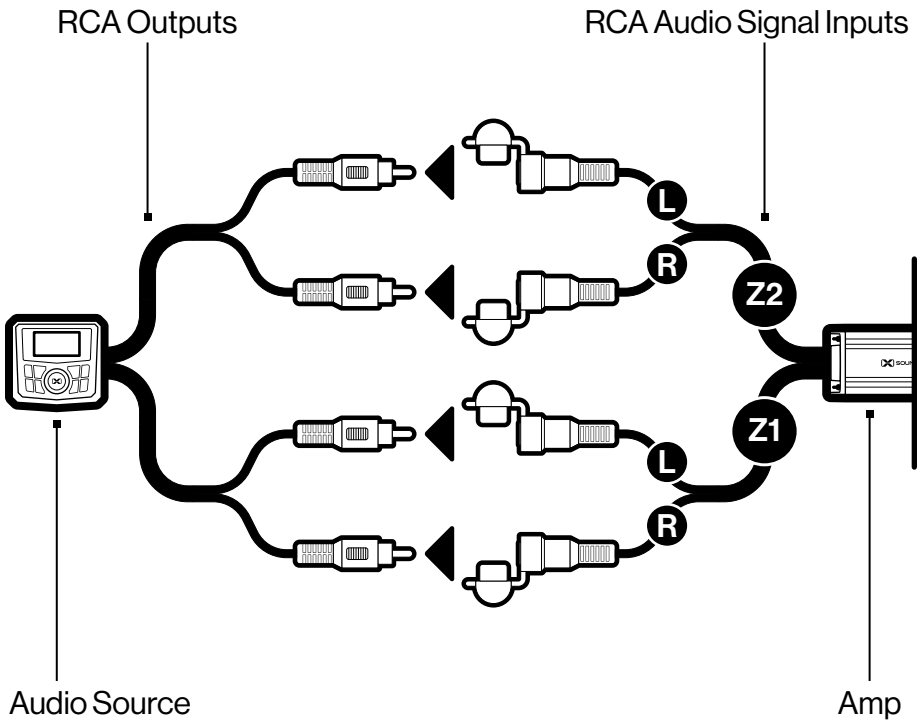

1. Connect the left and right RCA outputs from your audio source (e.g., the SoundExtreme Marine Gauge Radio) to the Amp's Left and Right RCA Audio Signal Inputs.

# Channel Mode and Bridge

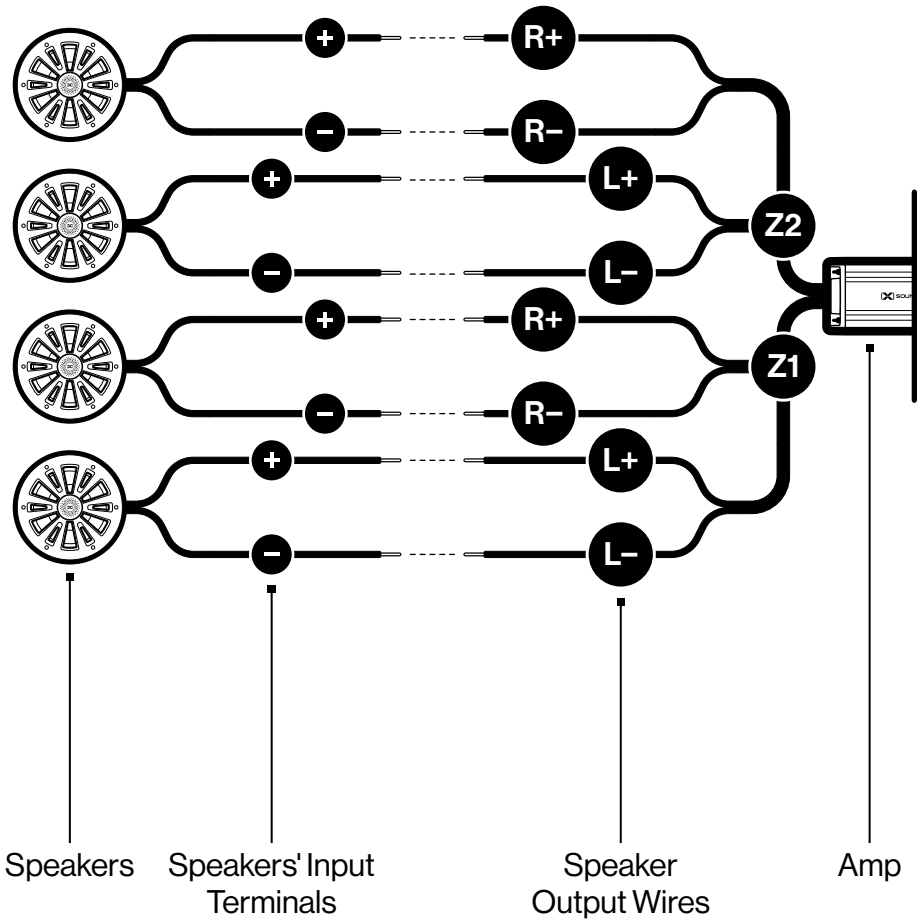

2. Connect the Left Speaker Output wires to the left speakers' positive and negative terminals and the Right Speaker Output wires to the right speakers' positive and negative terminals.

# Channel Mode and Bridge

## 4 CHANNEL SETTING AND WIRING 2 ZONES – EACH IN STEREO

Channel Mode Switch	Set to 4CH
Signal Range & Crossover	Independent Settings for 2 Zones
Amp Audio Output	Zone 1 – Stereo (Left and Right) Zone 2 – Stereo (Left and Right)
Audio Signal Inputs	Zone 1 – RCA (Left and Right) Zone 2 – RCA (Left and Right)
Speaker Outputs	Zone 1 – L Speaker (L+   L-), R Speaker (R+   R-) Zone 2 – L Speaker (L+   L-), R Speaker (R+   R-)
RMS Power	75W x 4 @ 4 ohms, THD+N < 2%

### 3 Channel Setting

If you only have 3 speakers (e.g. a pair of speakers and one subwoofer), you can still use the **4 Channel Setting** and leave one Speaker Output unconnected (not used).

### Channel Mode



2CH/3CH/4CH

However, you can also optimize (maximize) the Amp output power by setting it to 3 Channel Mode. In this Mode, Zone 2 is Bridged with the following wiring:

# Channel Mode and Bridge

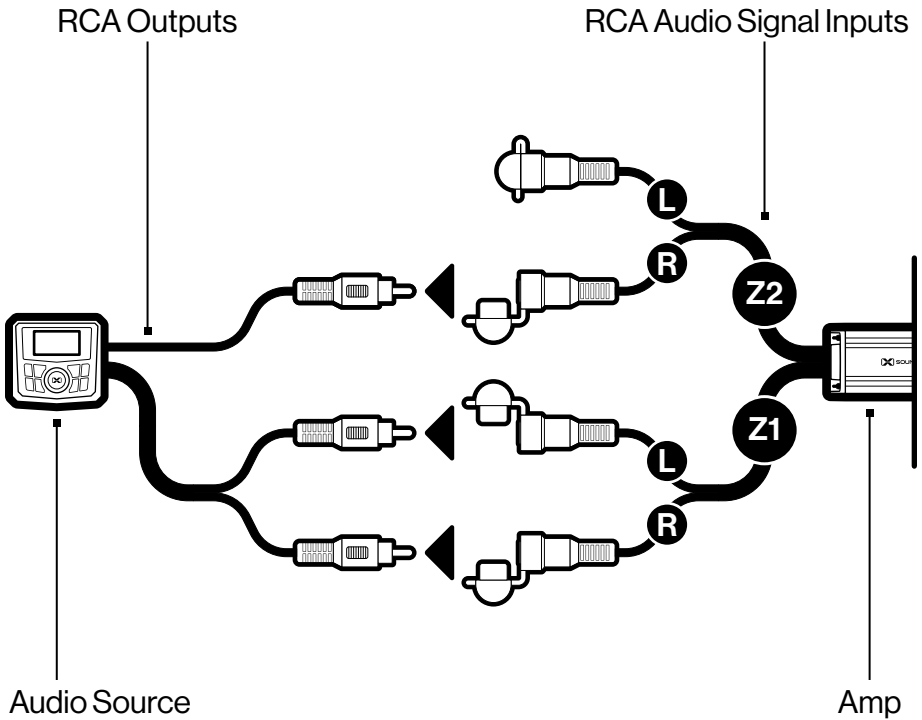

## 1. Audio Signal Inputs

- Connect the audio source's Zone 1 left and right RCA outputs to the Amp's Zone 1 Left (White) and Right (Red) RCA Audio Signal Inputs.
- Connect the audio source's Zone 2 right RCA output to the Amp's Zone 2 Right (Red) RCA Audio Signal Input. The Amp's Zone 2 Left (White) RCA Input is not used.

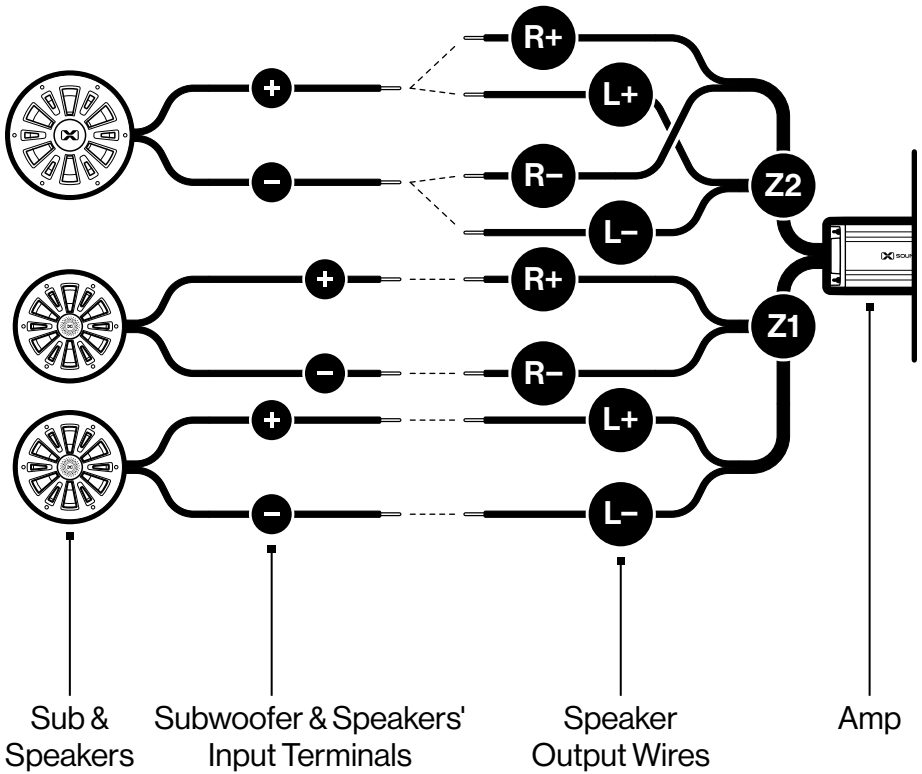

## 2. Speaker Outputs

- Connect the Zone 1 Speaker Output Left wires (L+ and L-) to the left speaker's positive and negative terminals and the Zone 1 Right wires (R+ and R-) to the right speaker's positive and negative terminals.
- Connect the Zone 2 Speaker Output positive Left and Right wires (L+ and R+) to the subwoofer's positive terminal and the Zone 2 negative Left and Right wires (L- and R-) to the subwoofer's negative terminal.

**Recommendation:** If connecting to a subwoofer, set the Zone's Crossover Mode Switch to Low Pass (LP) to optimize the Crossover Frequency setting.

# Channel Mode and Bridge

---

## 3 CHANNEL SETTING AND WIRING 1 ZONE IN STEREO + 1 ZONE BRIDGED IN MONO

Channel Mode Switch	Set to 3CH
Signal Range & Crossover	Independent Settings for 2 Zones
Amp Audio Output	Zone 1 – Stereo (Left and Right) Zone 2 – Bridged Mono
Audio Signal Inputs	Zone 1 – RCA (Left and Right) Zone 2 – Right RCA (Left RCA not used)
Speaker Outputs	Zone 1 – L Speaker (L+   L-), R Speaker (R+   R-) Zone 2 – Bridged Sub (L+ & R+   L- & R-)
RMS Power	75W x 2 @ 4 ohms + 150W @ 2 ohms, THD+N < 2%

## 2 Channel Setting

### Channel Mode



2CH/3CH/4CH

If you only have 2 speakers (that you want to designate as a left and right speaker in order to play your audio in stereo), you can maximize the Amp output power by setting it to 2 Channel Mode. In this Mode, both Zone 1 and 2 are Bridged with the following wiring:



# Channel Mode and Bridge

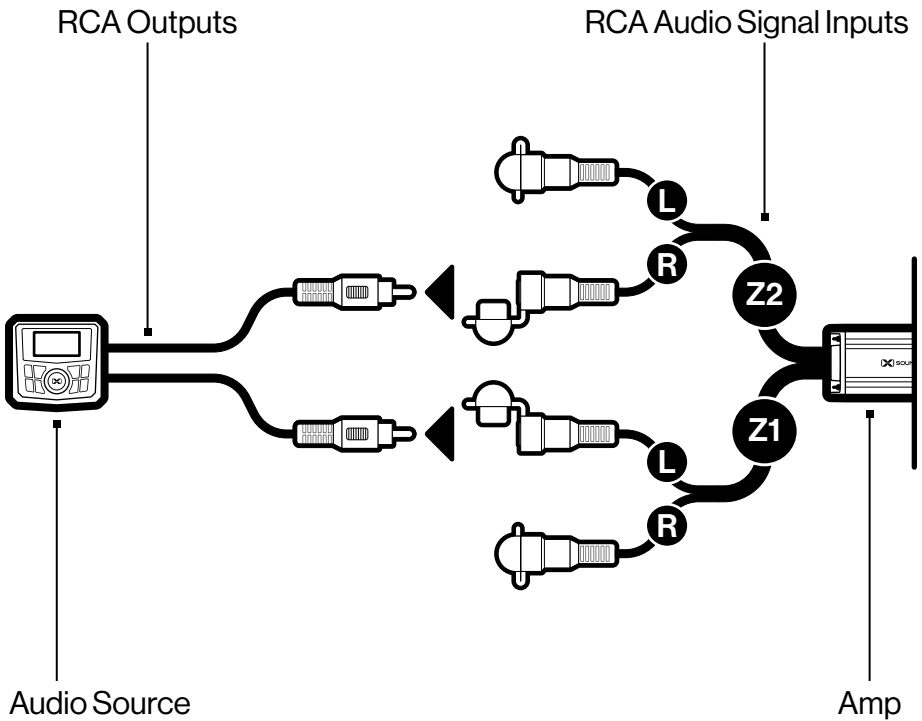

## 1. Audio Signal Inputs

- Connect the audio source's Zone 1 left RCA output to the Amp's Zone 1 Left (White) RCA Audio Signal Input. The Amp's Zone 1 Right (Red) RCA Input is not used.
- Connect the audio source's Zone 2 right RCA output to the Amp's Zone 2 Right (Red) RCA Audio Signal Input. The Amp's Zone 2 Left (White) RCA Input is not used.

# Channel Mode and Bridge

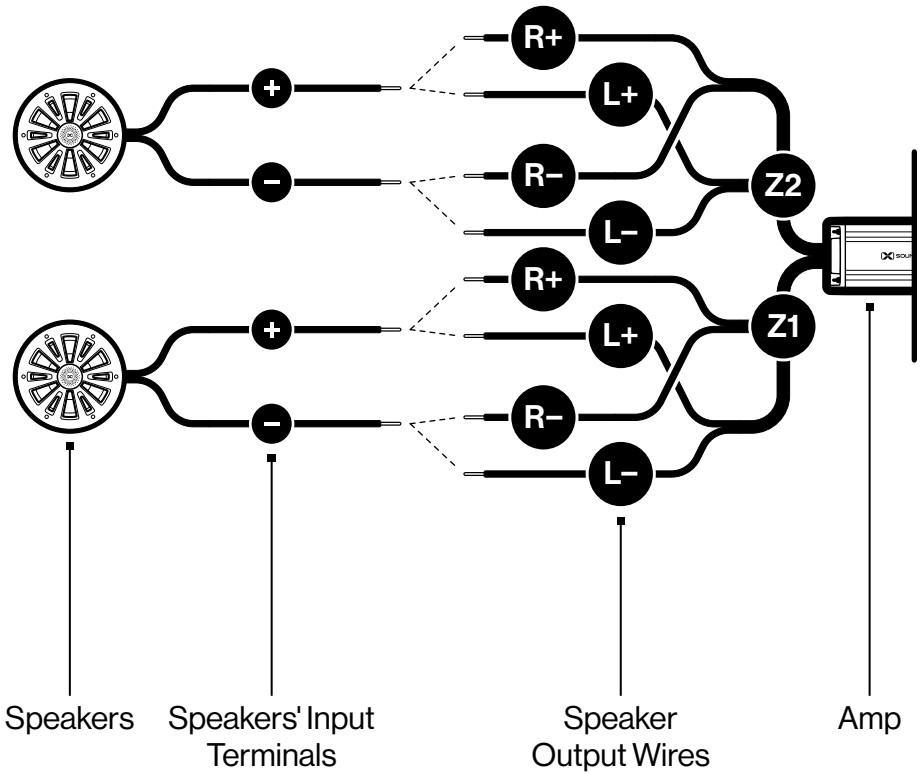

## 2. Speaker Outputs

- Connect the Zone 1 Speaker Output positive Left and Right wires (L+ and R+) to the left speaker's positive terminal and the Zone 1 negative Left and Right wires (L- and R-) to the left speaker's negative terminal.
- Connect the Zone 2 Speaker Output positive Left and Right wires (L+ and R+) to the right speaker's positive terminal and the Zone 2 negative Left and Right wires (L- and R-) to the right speaker's negative terminal.

# Channel Mode and Bridge

## 2 CHANNEL SETTING AND WIRING 1 ZONE BRIDGED IN STEREO

<b>Channel Mode Switch</b>	<b>Set to 2CH</b>
<b>Signal Range &amp; Crossover</b>	<b>Settings for 1 Zone</b>
<b>Amp Audio Output</b>	<b>Zone 1 – Stereo (Left and Right)</b>
<b>Audio Signal Inputs</b>	<b>Zone 1 – Left RCA (White) Zone 2 – Right RCA (Red)</b>
<b>Speaker Outputs</b>	<b>Zone 1 – Bridged L Speaker (L+ &amp; R+   L- &amp; R-) Zone 2 – Bridged R Speaker (L+ &amp; R+   L- &amp; R-)</b>
<b>RMS Power</b>	<b>150W x 2 @ 2 ohms, THD+N &lt; 2%</b>

# Installation and Wiring

---

## Installation and Wiring Safety

### Wiring Considerations

- **IMPORTANT: BEFORE** installation, disconnect any and all negative leads from the battery's negative (-) terminal to prevent damage to the unit, fire, and/or possible injury.
- **BEFORE** wiring and connecting the Amp, disconnect the device(s) you are connecting to from their respective power source(s) to ensure no damage is done to the amplifier or audio source devices. Failure to do so could result in permanent damage to the audio system, amplifier, or connected speaker(s).
- For easier assembly, it is recommended you run all wires prior to mounting your unit in place.
- Plan out your system layout and best wiring routes to save installation time. Carefully route all system wiring away moving parts and sharp edges; secure with cable ties or wire clamps and use rubber or plastic grommets where appropriate to protect from sharp edges.
- To avoid short-circuiting, cover any disconnected leads with electrical tape. It is important to insulate any unused wires, which, if left uncovered, may cause a short circuit.
- Route the RCA cables close together and isolated from the Amp's power cables and any high-power / high-current wires and auto accessories, especially electric motors. This is to prevent coupling the noise from radiated electrical fields into the audio signal.
- When connecting two wires, make sure to seal the connection either by using electrical tape or heat shrink tubing. Failing to do this may result in long-term corrosion on the connection and cause a premature malfunction.
- Use high-quality, audio cables and connectors to minimize signal or power loss.

- Do **NOT** connect the Power Cable to your Vehicle's battery until all the installations and wirings are completed.

## Mounting Considerations

- Mount the Amp in a dry, well-ventilated location, not in a spot exposed to direct sunlight or excessive heat.
- Be sure that the Amp's Control Panel will be easily accessible if future adjustments are desired.
- Securely mount the amplifier so that it does not come loose due to severe conditions or sudden stops.

## Input Voltage and Cross Over Frequency Considerations

Before you connect your audio source's outputs into the Amp's inputs, you need to check what the audio source's output voltage level is in order to set the Input Voltage Switch to the correct position.

- If your audio source's output voltage is between 250mV and 4V, set the switch to the Low position.
- If the voltage is between 750mV and 15V, set the switch to High.

If you don't have your audio source's output voltage information, you can follow the guidance below.

**Note:** Set your audio source volume level to a mid-range level when performing these tests. A high volume level may destroy your speakers and a low volume level may be difficult to hear.

- If you connect the audio source's RCA/Preamp outputs into the Amp's input, set the Input Voltage Switch to Low.
- If you find that the Amp's speaker output signal is distorted, then change the Switch setting to High.
- If you connect the audio source's speaker outputs into the Amp's input, set the Input Voltage Switch to High.

# Installation and Wiring

---

After you select the Input Voltage settings, you will need to adjust the Crossover Frequency settings based on the type of speaker you want the Amp to drive in each Zone:

- Set the X-Over Mode Switch to Off. This will disable the Low and High Pass filters. Therefore, the full frequency range (20 – 20kHz) will pass through, no matter the X-Over Freq Dial setting.
- Set the X-Over Mode Switch to High and turn the X-Over Freq Dial to a selected Crossover Frequency between 20Hz and 6kHz. This will filter out the audio signals with frequencies below the selected Crossover Frequency. These outputs are normally utilized for midrange speakers or pro audio tweeters.
- Set the X-Over Mode Switch to Low and turn the X-Over Freq Dial to a selected Crossover Frequency between 20Hz and 6kHz. This will filter out the audio signals with frequencies above the selected Crossover Frequency. These outputs are normally utilized for midrange speakers or subwoofers.

## System Wiring

1. **BEFORE** connecting any wires / cables, turn off all the audio devices (powered speakers, amplifier, and audio source), then disconnect any and all negative leads from the battery's negative (-) terminal to prevent damage to the unit, fire, and / or possible injury. Secure the disconnected cables to prevent accidental reconnection during installation.
2. Grounding: Locate a proper ground point on the vehicle's chassis and remove all paint, dirt or debris to reveal a bare metal surface. Attach the ground wire (not included) to that contact point. Connect the opposite end of the ground wire to the Amp's **BLACK** Power Input GND wire. If no metal chassis ground is available, it may be necessary to make this connection to the **NEGATIVE (-)** battery terminal. All ground connections (audio source unit and amplifiers) should be made at the same location.

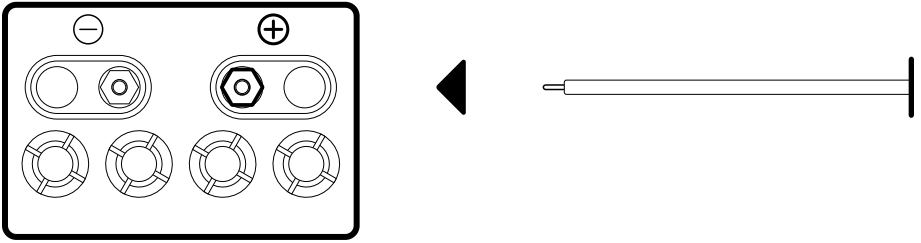

3. Connect the Amp's **RED** Power Input wire to the **POSITIVE** (+12V) battery terminal. An 8 AWG (or higher) extension cable is recommended. (Extension cable not included).



4. Connect the **TURQUOISE** Remote Turn-On wire to the audio source unit's positive (+12V) amplifier-on or remote turn-on output.

If your audio source unit does not have a dedicated amplifier-on or remote turn-on output, the Amp's Remote Turn-on Input cable can be connected to a +12V input via a switch that derives power from an ignition-switched circuit.

5. Based on your audio system configurations, audio input level, and speaker type, do the following:
  - Set the Input Voltage Switch to Low or High, depending on the audio source.
  - Set the Channel Mode Switch to 2CH, 3CH, or 4CH.

# Installation and Wiring

---

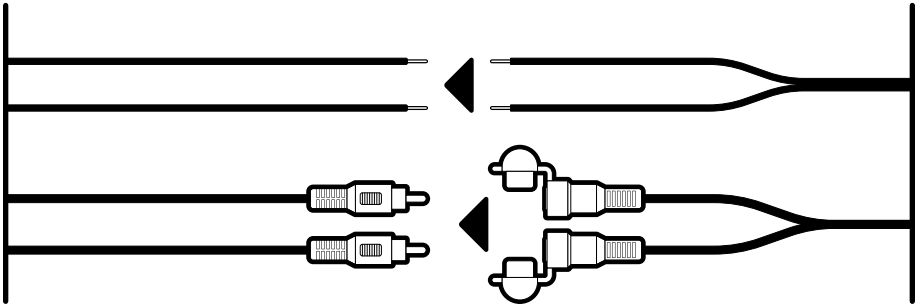

- Make the audio input and speaker output connections, per the selected Channel Setting and wiring as described under **Channel Mode and Bridge**.
6. Perform a final check of the completed system wiring to ensure that all connections are accurate.
- If you bridge the Amp, check if any of the positive Speaker Output wires were accidentally connected to any negative wires.
- Warning:** Under no circumstances should the positive and negative Speaker Outputs connect to each other. Doing so will result in a short-circuit.
- Check all the unused Speaker Output wires, making sure they are insulated to prevent a short-circuit.
  - Check all power and ground connections.
7. Turn the Amp's Input Voltage levels all the way down (clockwise).
8. Reconnect the vehicle's negative battery cable back to the battery. Also reconnect any additional devices back to their respective power sources.
9. Turn on the Audio Source.



10. Check if the Amp's LED Status Indicator shines solid Green. If not, refer to **Troubleshooting**.
11. While the audio is playing, make any necessary adjustments.
  - Slowly turn up the Input Voltage Dial level (turn counterclockwise) so that the audio volume is maximized without clipping.

**IMPORTANT:** The Input Voltage Dial needs to be set to a proper level where no audio distortion is heard when the audio source plays music at least one or two steps lower than maximum volume.
  - Slowly turn the X-Over Freq Dial until a desired crossover point is achieved.
12. Once the installation is completed, put the Cover back on the Settings and Controls Panel and tightly screw in the panel to ensure it is properly sealed. Failing to properly seal your device may result in potential moisture intrusion that may damage the internal electronics.

# Troubleshooting

---

<b>PROBLEM</b>	<b>CAUSE</b>
<b>Amp LED off</b>	<b>No power at Remote Turn-On Wire</b>
	<b>No power at Power-In Wire</b>
	<b>Insufficient Ground connection</b>
	<b>Blown power fuse</b>
<b>Amp LED on, but no Audio Output</b>	<b>Audio source volume is off</b>
	<b>Speaker connections incomplete</b>
	<b>Input Voltage level too low</b>
<b>Distorted Audio Output</b>	<b>Audio source volume set too high</b>
	<b>Amp Input Gain set too high</b>
<b>LED Status Indicator flashing Orange and Green</b>	<b>Speaker output short-circuit</b>
	<b>Amp output current too high</b>
	<b>Amp is overheated</b>

## **SOLUTION**

**Supply +12V to terminal**

**Supply +12V to terminal**

**Check Ground connection**

**Check the root cause and replace fuse**

**Increase audio source volume**

**Complete Speaker Output connections**

**Turn the Input Voltage Dial counterclockwise to increase the volume**

**Lower audio source volume**

**Turn the Input Voltage Dial clockwise to lower the volume**

**Check speaker output wiring and fix if connections are wrong**

**Lower audio source volume**

# Specifications

---

## Dimensions

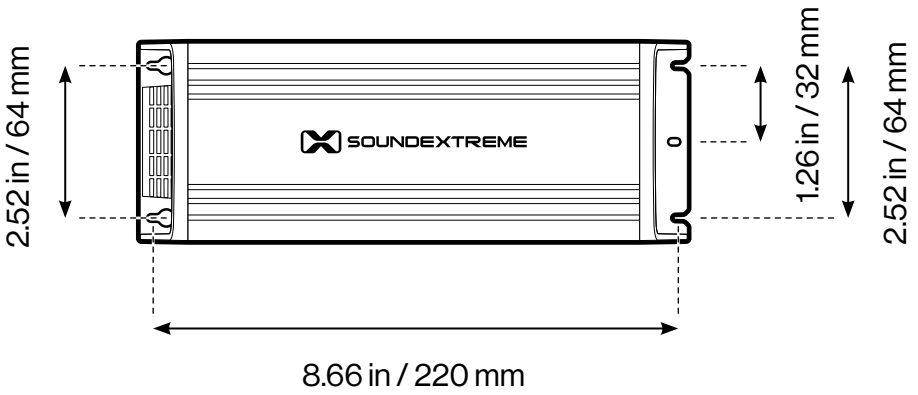
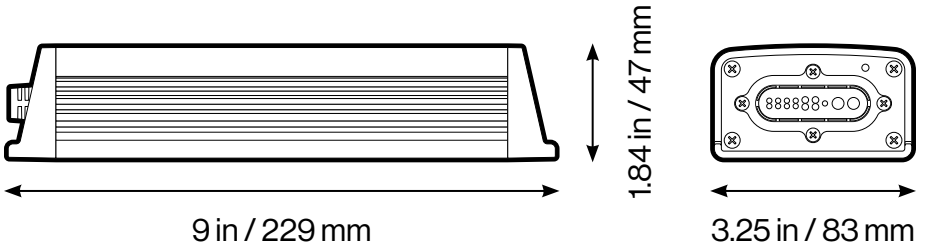

**Unit Weight**

2 lbs (907 g)

**Operating Voltage Range**

11.5V – 18V

**Remote Turn-On Operating Voltage Range**

10V – 15V

**Power Input in-line Blade Fuse**

35A, 32V

**Power Output**

75 Watts RMS x 4

**Amplifier Class**

Class D

**Current Draw**

Standby 5mA / On 330mA,  
@ 14.4V

**Input Voltage Range**

- Low Position: 500mV – 3V
- High Position: 3V – 14.5V

**Frequency Response**

20Hz – 20kHz, +/-1dB

**High Pass Filter**

20Hz – 6kHz, 24dB /Octave

**Low Pass Filter**

55Hz – 6kHz, 24dB /Octave

**Input Impedance**

15k ohms

**Input Sensitivity**

500mV @ rated power  
output, 4 ohms

**Signal to Noise Ratio**

- Low Voltage Input: 86dB @  
rated power output, 4 ohms
- High Voltage Input: 93dB @  
rated power output, 4 ohms

**Connector Cables – Length**

11 in (279.4 mm)

**Waterproof / Dust Rating**

IP67

**Storage Temperature**

-40°F to 122°F / -40°C to 50°C

**Operating Temperature**

23°F to 95°F / -5°C to 35°C

# Important Legal Information

---

## FCC STATEMENT:

This device complies with Part 15 of the FCC Rules. Operation is subject to the following two conditions:

- 1.) This device may not cause harmful interference, and
- 2.) This device must accept any interference received, including interference that may cause undesired operation.

**WARNING:** Changes or modifications not expressly approved by the party responsible for compliance could void the user's authority to operate the equipment.

**NOTE:** FCC's RF Exposure guidelines, this equipment should be installed and operated with minimum distance between 20cm the radiator to your body.

This equipment has been tested and found to comply with the limits for a Class B digital device, pursuant to Part 15 of the FCC Rules. These limits are designed to provide reasonable protection against harmful interference in a residential installation. This equipment generates, uses, and can radiate radio frequency energy and, if not installed and used in accordance with the instructions, may cause harmful interference to radio communications. However, there is no guarantee that interference will not occur in a particular installation. If this equipment does cause harmful interference to radio or television reception, which can be determined by turning the equipment off and on, the user is encouraged to try to correct the interference by one or more of the following measures: reorient or relocate the receiving antenna, increase the separation between the equipment and receiver, connect the equipment into an outlet on a circuit different from that to which the receiver is connected, consult the dealer or an experienced radio/TV technician for help.

## RF WARNING STATEMENT:

The device has been evaluated to meet general RF exposure requirement. The device can be used in portable exposure condition without restriction.

## IC STATEMENT:

This device complies with Industry Canada licence-exempt RSS standard(s). Operation is subject to the following two conditions:

- 1.) This device may not cause interference, and
- 2.) This device must accept any interference, including interference that may cause undesired operation of the device.

## PRODUCT USE AND PROTECTION:

**Read and follow all instructions. Use only as intended.**

The SoundExtreme unit is intended to be used indoors or outdoors and in land or water environments. The unit has been tested to IP67 waterproofing standards, which means the unit can be exposed to dust and water, but should **NOT** be submerged underwater.

To prevent fire or shock, do **NOT** attempt to power this unit if it is wet or you suspect water has entered the unit. In this situation, please return the unit to SoundExtreme for a free assessment. If we have found that the unit has carried water, we will repair or replace the unit free of charge.

## SAFETY ADVISORY & WARNING:

**Read and follow all instructions. Use only as intended.**

**CAUTION:** Do **NOT** open to repair. A qualified technician must carry out repair work.

**ATTENTION:** Do **NOT** connect to a 12VDC power supply while the unit is wet. Make sure all connections are dry **BEFORE** connecting to a power source. Failure to do so may result in electrical damage to the unit and may void the warranty.

 **WARNING:** Cancer and Reproductive Harm - [www.P65Warnings.ca.gov](http://www.P65Warnings.ca.gov)

**ATTENTION:** Do **NOT** dispose of in a landfill. Contact SoundExtreme at [www.gracesupport.com](http://www.gracesupport.com) or a certified recycling agent to dispose of the unit.

## SAFETY:

This product has a limited life span of use and should be replaced when it shows obvious signs of wear.

Do not modify or remove any original component parts of the speaker. Doing so could cause damage to the unit, allowing water to ingress. A unit with water ingress should not be charged due to potential risk of fire or shock.

Please exercise care and good judgment when using your SoundExtreme unit.

**You should always**

- 1.) Return the unit to SoundExtreme if you suspect water ingress into the unit or if the unit has experienced a severe impact that may have affected the integrity of the unit to take on water.

# Important Legal Information

---

## You should never

- 1.) Never power your SoundExtreme unit if you suspect water has entered the device. Powering a device with water inside could be potentially hazardous and cause fire or a spark.
- 2.) Never use your SoundExtreme unit if you have dropped it or thrown it against a hard surface which may have destroyed the integrity of the housing. In the event of a severe impact to your unit, please return the unit to SoundExtreme to review for potential damage.
- 3.) Never attempt to fix, repair your SoundExtreme unit. Please send it back to SoundExtreme for any assessments and repairs.

## CARE, MAINTENANCE & PRECAUTIONS:

- 1.) Do **NOT** apply excessive force to any surfaces of the unit.
- 2.) Do **NOT** use or store the unit in places with high temperature.
- 3.) **AVOID** prolonged exposure to ultraviolet radiation (UV sunlight) and strong magnetic fields.

## LIMITED MANUFACTURER'S WARRANTY:

The 4 Channel Amplifier is covered by a 1-year limited warranty that covers defects in workmanship and / or materials for a period of 1 year from original purchase date. This warranty does not apply to any products which have been abused, neglected, modified or used for a purpose other than the one for which they were manufactured. Please refer to the above care and maintenance instructions for suggested care details. The warranty is valid only for the original owner who purchases the unit from an authorized dealer. Transfers do not qualify for warranty protection. SoundExtreme reserves the right to replace any out-of-stock or discontinued product with a comparable product. Discontinued products may not be available for warranty replacement. Any contents are **NOT** covered by the limited manufacturer's warranty. Warranty terms may be revised without notification at the discretion of the manufacturer. Please visit [www.soundextreme.com](http://www.soundextreme.com) for additional product & warranty information.



4 Channel Amplifier by SoundExtreme Inc., Houston, Texas.  
Designed in Texas. Made in China.

# What's in the Box

---

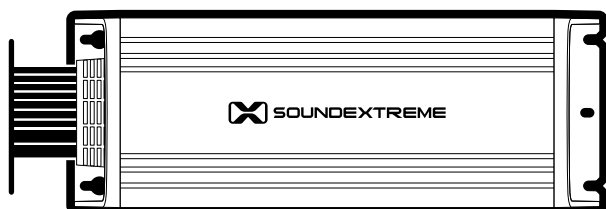

4 Channel Amplifier



(4x) 1" Self-Tapping Screws



User Guide

V03.24