

# RETROLIFE

## ALL-IN-ONE TURNTABLE

MODEL: R517



### **Instruction Manual**

PLEASE READ THIS MANUAL CAREFULLY BEFORE USE AND KEEP IT  
FOR FUTURE REFERENCE

Support@retrolifeplayer.com  
retrolifeplayer.com

## BEFORE USE

1. Choose a safe location and avoid placing the unit in direct sunlight or near any heat source.
2. Avoid environments subject to vibration, excessive dust, cold or moisture.
3. Due to the risk of electrical shock, do not open the cabinet. Should a foreign object accidentally find its way into the interior of the unit, contact your local dealer.
4. Do not attempt to clean the unit with chemical solvents as this might damage the finishing. A clean, dry cloth is recommended for cleaning.
5. Keep this manual for future reference.

## TURNTABLE PARTS:

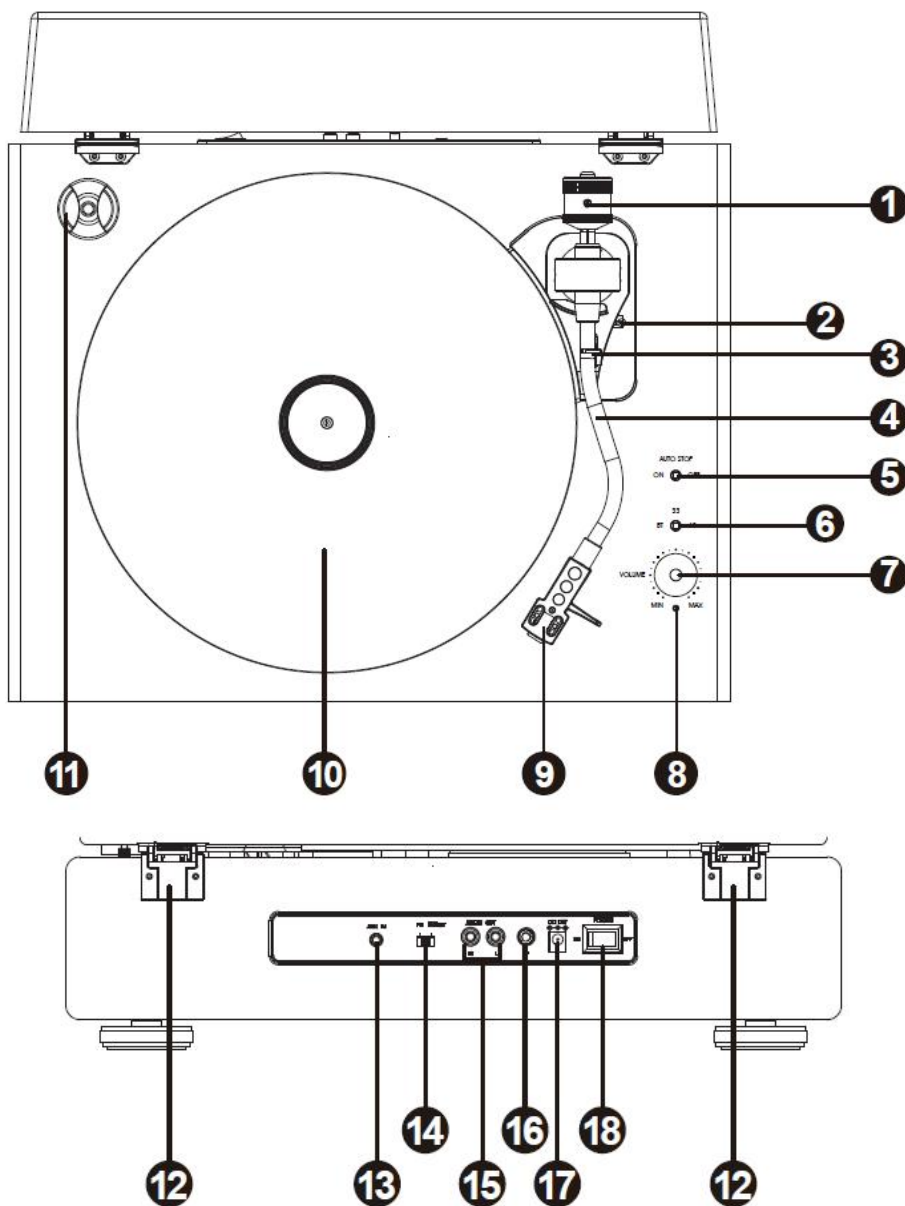

1. Tonearm Counterweight—adjust the counterweight to make sure that the needle pressure is at 3G, +0.5G measured by a needle balance(not included in the package)
2. Lift Lever
3. Tone-arm Clip
4. Tone-arm
5. Auto Stop ON/OFF Switch
6. Function/Speed Switch
7. Volume Control Knob
8. LED Indicator
9. Stylus/Needle Cartridge—Audio Technica AT-3600L MM cartridge
10. Platter
11. 45RPM Adaptor
12. Hinges—Fix the dust cover to the two hinges
13. 3.5MM AUX IN Jack
14. Phono/Line Out Mode Switch—Only used when connecting to external speaker system
15. L/R RCA Output Jack—to connect other external amplifier or speaker system with RCA audio cable(not included in the package)
16. Ground Connector—Only used when connecting to external speaker system
17. DC IN Power Jack—to connect power adaptor for power
18. Power ON/OFF Control Switch

## Getting Started

Fix the dust cover onto the main unit via the two hinges.

Firmly and securely insert the DC plug of the adaptor to the DC IN Jack on the back of the unit. Plug the adaptor's AC plugs into a power outlet.

Turn on the unit by switching the Power On/Off Switch to the ON position.

## Phono Mode

1. Place a record on the turntable platter and select the desired speed (33/45 RPM) by switching the Function/Speed Switch according to the record. **NOTE:** when playing a 45RPM record, use the 45RPM adapter

2. Remove the stylus protector. Open the tone-arm clip to release the tone-arm. Push the lift lever backward to raise the tone-arm and gently move the tone-arm to the desired position over the record. The turntable will begin to spin when the arm is moved toward the record when the AUTO STOP switch is ON.

Push the lift lever forward to lower the tone-arm slowly onto the desired position on the record to begin playing the record.

3. Turn the VOLUME CONTROL KNOB to adjust the volume.

**Remark: AUTO STOP function applies to most 33RPM vinyl records. However, for very few vinyl records, it will stop when it does not come to the end(in this case, turn the AUTO STOP switch to OFF position and then it will continue playback), or it will not stop when it comes to the end when AUTO STOP is ON.**

**Remark: This product has built-in speakers. When you listen to vinyl music via the**

**built-in speakers, please make sure that the RCA OUTPUT jack and AUX IN jack are not plugged in by any audio cable.**

## **Bluetooth Mode**

1. Switch the Function/Speed Switch to BT. The LED indicator will become blue color with flashing.
2. Turn on your Bluetooth function on your mobile phone or tablet PC and then search the turntable player with its name Vintage Turntable. After pairing and connection, the LED indicator will become blue color without flashing, and you can play your music of your mobile phone or tablet PC on this turntable player.
3. Turn the VOLUME CONTROL KNOB to adjust the volume.

**Remark: the mobile phone or tablet PC's volume level also impact the overall volume; please adjust that as well to have a satisfying sound.**

## **AUX IN Mode**

1. Connect your iPod, MP3 player, mobile phones etc. to the AUX IN Jack with a 3.5mm-3.5mm audio cable(not included in the package).
2. You can enjoy the music of iPod, MP3 player, mobile phones etc. at the turntable player.
3. Turn the VOLUME CONTROL KNOB to adjust the volume.gers

**Remark: the volume level of iPod, MP3 player, mobile phones etc. also impact the overall volume; please adjust that as well to have a satisfying sound.**

## **Connecting With External Amplifier/Speaker System**

At phono mode or Bluetooth Mode, this turntable player can connect to other external amplifier or speaker system via the RCA output jack. There are two modes.

### **Mode One:**

When Phono/Line Out Mode Switch is switched to PH mode, connect the turntable to the external phono amplifier and then connect the phono amplifier to the speaker system(with power amplifier built-in)

### **Mode Two:**

When Phono/Line Out Mode Switch is switched to LINE OUT mode, connect the turntable to the speaker system(with power amplifier built-in).

**Remark: During music playback via the external amplifier or speaker system, there is sound coming from the built-in speakers as well; turn the VOLUME CONTROL KNOB to MIN to have a satisfying sound.**

## **TIPS FOR BETTER TURNTABLE PERFORMANCE**

1. When opening or closing the turntable cover, handle it gently
2. Do not touch the needle tip with your fingers; avoid bumping the needle against the turntable platter or record edge.
3. Gently wipe the dust cover and turntable housing with a soft cloth. Use only a small amount of mild detergent to clean the turntable and dust cover.
4. Never apply harsh chemicals or solvents to any part of the turntable system.