

ROADWARE MatchCrete™ Clear Application Chart

For Professional Use Only
READ ALL DIRECTIONS CAREFULLY BEFORE USE!

Tools Recommended for Concrete Repair:



Roadware Sylcat 100. For easy dispensing of Roadware 300 x 300 ml Cartridges

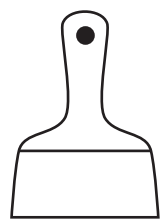

4" Taping knife for smoothing repairs

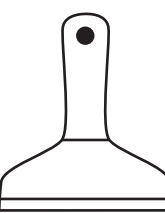

Sharp scraper for shaving off cured material.



Wire brush for cleaning cracks and spalls

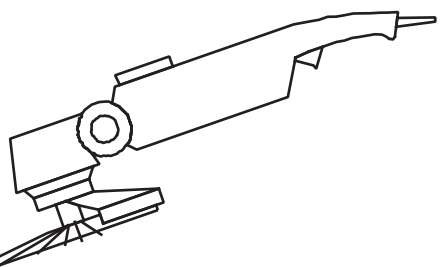

4" Grinder with a diamond blade or twisted wire wheel for cleaning cracks and spalls

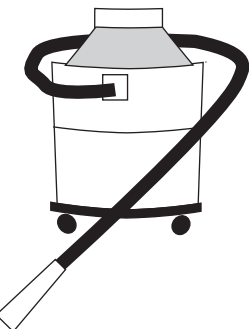

Shop vacuum for cleaning out dust and debris from cracks and spalls



20 - 40 grit manufactured silica sand. Used for repairing cracks and spalls.



Gloves



Safety Glasses

Cartridge Assembly Instructions

Each cartridge set contains the following:

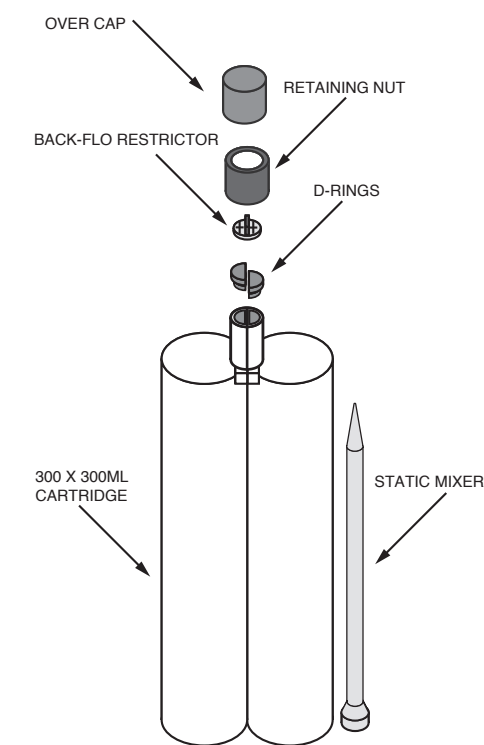

1

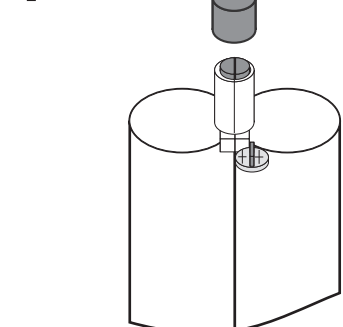

Step 1: Remove over cap and wipe off excess sealant material.

2

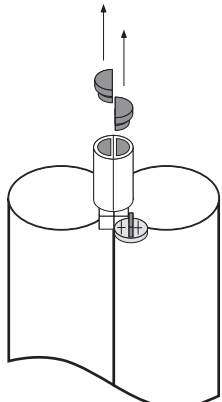

Step 2: Remove black D-rings and save.

3

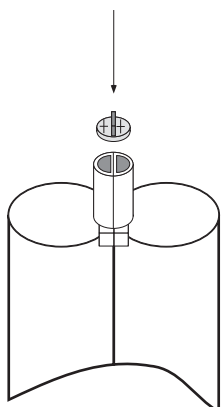

Step 3: Place back-flow restrictor on top of cartridge. Be careful to align material openings.

4

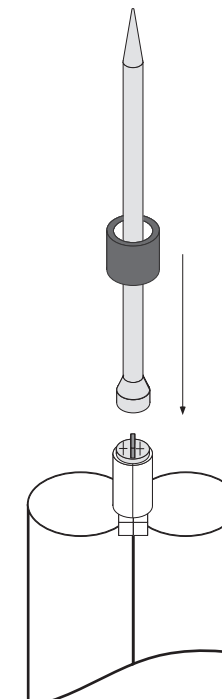

Step 4: Place static mixer over the Back-flow restrictor and secure with black retaining nut.

5

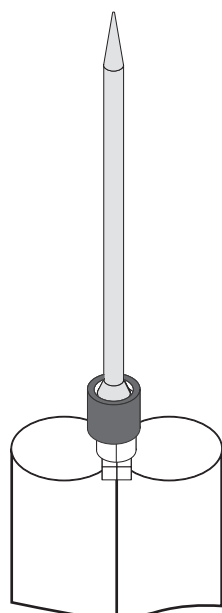

Step 5: Tighten firmly with hands. KEEP CARTRIDGE UPRIGHT UNTIL USE.

Cartridge Start-up Procedure

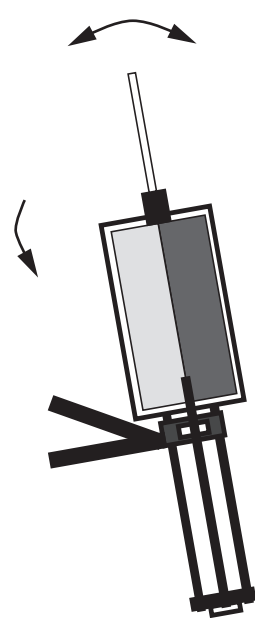

Hold cartridge upward and load into gun. Bleed off any air inside the cartridge by slightly squeezing handle and rocking the cartridge from side to side as needed to force the air bubble out through the mixer.

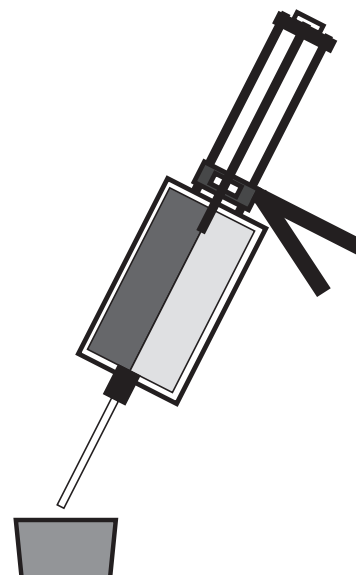

Immediately point mixer into a waste container and apply a small amount to start the material mixing.



CAUTION: DO NOT POINT MIXER UPWARD AFTER MATERIAL IS FLOWING! This may cause Back-flo and clogging.

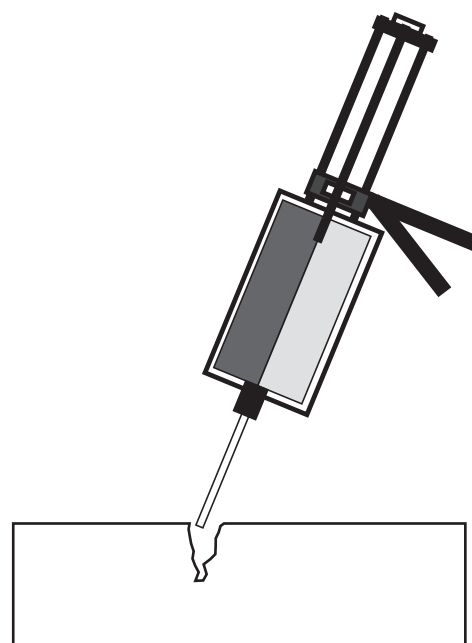

Apply material immediately, with a gentle trigger motion.

Crack Repair Spalled Control Joint Repair

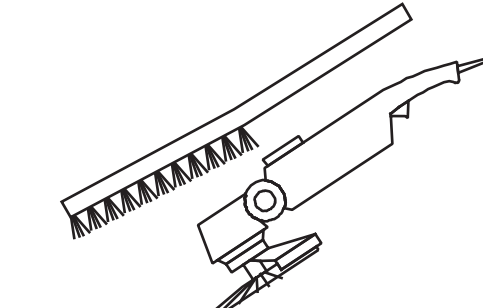

Clean repair area. Remove all dirt, oils, and loose debris. **Surfaces must be dry.**

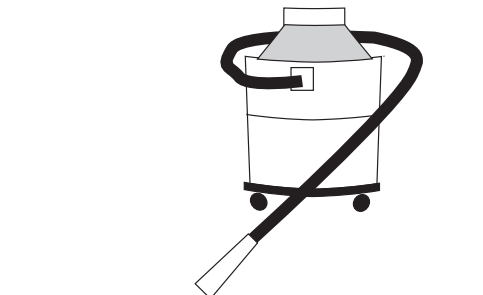

Remove any dust with a vacuum or compressed air.

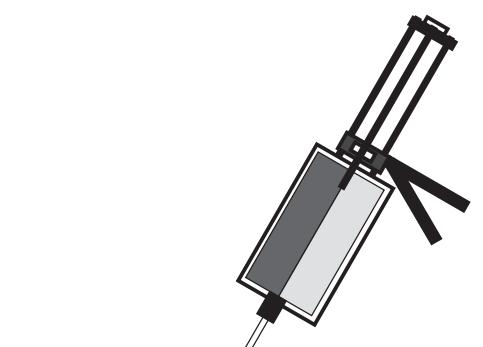

For cracks and joints pre-wet with Roadware MatchCrete™ Clear.

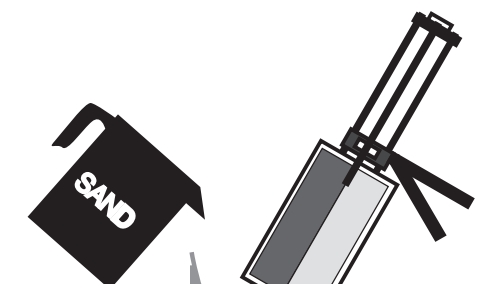

Immediately add dry silica sand and more MatchCrete™ Clear. Add enough material to slightly overfill the repair. Use enough liquid to completely saturate the sand.

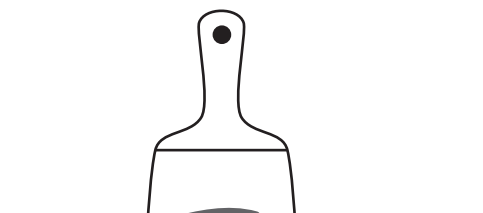

Use a tapping or putty knife to smooth and shape the sand and material mixture. Cement powder may be added at this time to blend the repair with existing concrete.

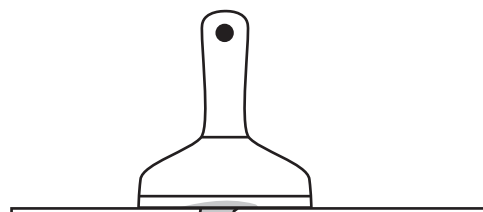

When material cures (in about 30 minutes), scrape off over banding with a sharp scraper or sand off with a rubbing brick.



Finished repair is open for all traffic. Any staining due to over banding will quickly wear off or can be removed with a light sanding.

Spall Repair

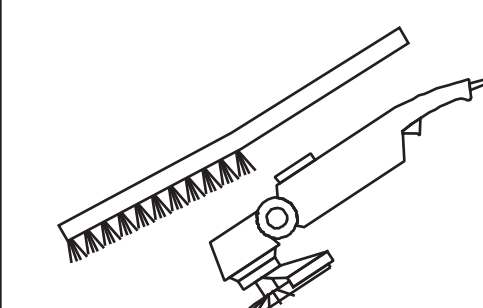

Clean repair area. Remove all dirt, oils, and loose debris. **Surfaces must be dry.**

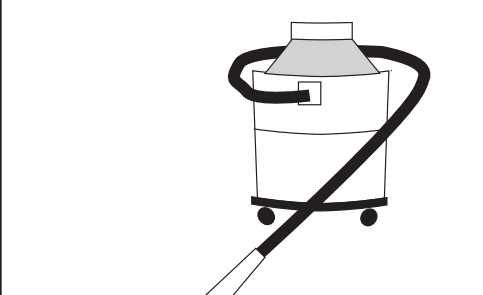

Remove any dust with a vacuum or compressed air.

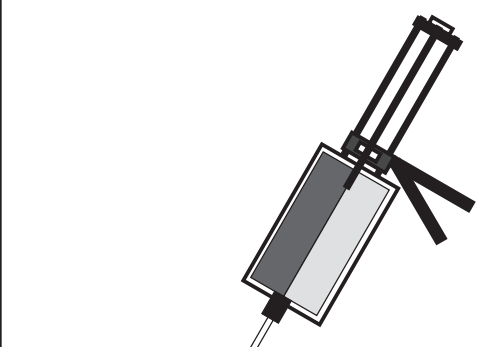

For spalls, pre-wet with MatchCrete™ Clear.

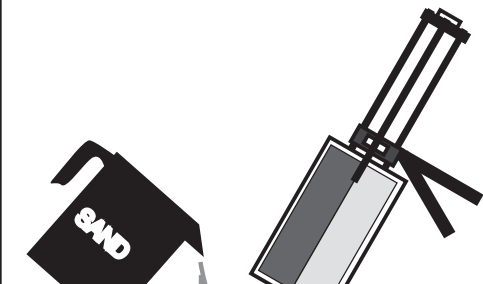

Immediately add dry silica sand and more MatchCrete™ Clear. Add enough material to slightly overfill the repair. Use enough liquid to completely saturate the sand.



Use a tapping or putty knife to smooth and shape the sand and material mixture. Cement powder may be added at this time to blend the repair with existing concrete.

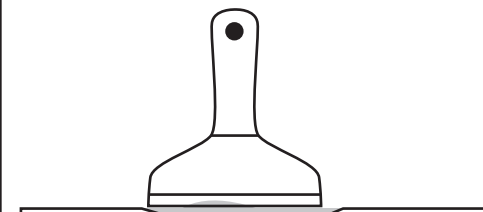

When material cures, scrape off over banding with a sharp scraper.



Finished repair is open for all traffic. Any staining due to over banding will quickly wear off or can be removed with a light sanding.

Recapping Partially Used Tubes

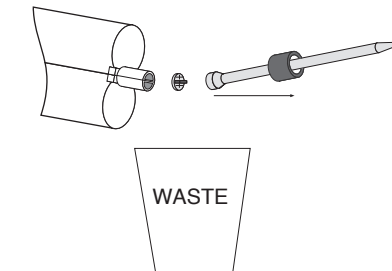

Hold cartridge sideways over a waste container and remove retaining nut, mixer, and Back-flow restrictor.

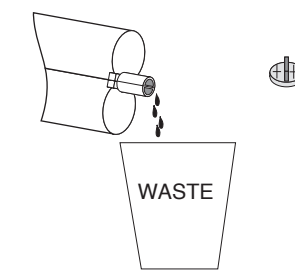

Bleed off a few drops of material to clear out any cured product. Clean or replace Back-flow restrictor.

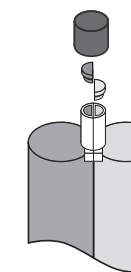

Hold cartridge upright and place D-rings into the top ports. Place overcap on cartridge.

Store upright in a cool, dry place. Material will remain usable for a varying amount of time depending on the moisture level of the storage area. Signs of moisture contamination are heavy caking and crystallization of the A-side material at the D-rings and the rear seals.

To reuse cartridge, follow normal start-up procedures.

Trouble Shooting

Every reasonable effort is made to insure every cartridge of Roadware MatchCrete™ Clear is easy to use and trouble free. Below is a list of possible problems, their causes and suggested solutions. For more information, please call Roadware Technical Service at 800-522-7623.

Problem: Material does not cure.
Cause: Material was not mixed properly.
Solution: Make sure all start-up procedures are followed. Check for any blockage of cartridge openings.

Problem: Material is slow to cure.
Cause: Low ambient temperature
Solution: This material will set in approximately 30 minutes at 72° F. Cooler concrete and sand temperatures will increase cure time.

Problem: Cartridge is hard to pump or surges off ratio.
Possible Cause: Rear plunger is sticking. Slight leakage (mostly found in partially used cartridges) has caused the "A" (light colored) material to crystallize on the plunger causing sticking and surging.
Solution: Carefully rim the skirt of the plunger seal with a small, flat screwdriver.
Possible Cause: Material has cured inside the static mixer or Back-flow restrictor.
Solution: Replace static mixer and Back-flow restrictor if needed.

Problem: Cured material has soft spots.
Possible Cause: Inadequate mixing.
Solution: Follow start up procedures carefully. Make sure all air pockets are bled off before application. Use medium even strokes when applying material.
Possible Cause: Improperly placed or missing Back-flow restrictor.
Solution: Make sure the wipers in the Back-flow restrictor line up with the openings in the cartridge. Hold the static mixer in place when securing the retaining nut to prevent the Back-flow restrictor from twisting.

Problem: Material grows, foams or bubbles when curing.
Cause: Moisture is in contact with the material.
Solution: Apply to dry surfaces only. Use Roadware 10 Minute Concrete Mender as a primer if necessary.

Clean up

Wipe tool clean with a rag before material is allowed to cure. Cured material may be removed by abrading with a wire brush or soaking in acetone, xylene, MEK, or epoxy thinner. USE EXTREME CARE WHEN WORKING WITH INDUSTRIAL SOLVENTS.

Roadware MatchCrete™ Clear is may be harmful to exposed skin in liquid form. Gloves should be worn to keep material from contacting skin. In the event of skin contact, flush with water. Remove immediately with an industrial paint and stain hand cleaner.

SEE MSDS SHEETS FOR FURTHER INFORMATION

Disposal Methods

Empty cartridges may be disposed of with normal waste disposal methods in accordance with Federal, State, and local environmental control regulations.

Unused material is best disposed of by mixing equal parts of side A and side B and allowed to cure in a waste container. DO NOT DISPOSE OF UNCURED MATERIAL DOWN THE DRAIN OR IN SEWER SYSTEM. SEE MSDS SHEETS. Cured material may then be disposed of with normal methods.

ACTION TO TAKE FOR SPILLS/LEAKS: Properly protected personnel should contain spill. Ventilate area, cover spill with sawdust or other absorbent material. Scoop and place in open container and treat with decontamination solution (93% water, 5% ammonia, 2% detergent). Leave open in a ventilated area for 24 hours.

DISPOSAL METHOD: Bury or landfill decontaminated waste in accordance with Federal, State, and local environmental control regulations.

SEE MSDS SHEETS FOR FURTHER INFORMATION