

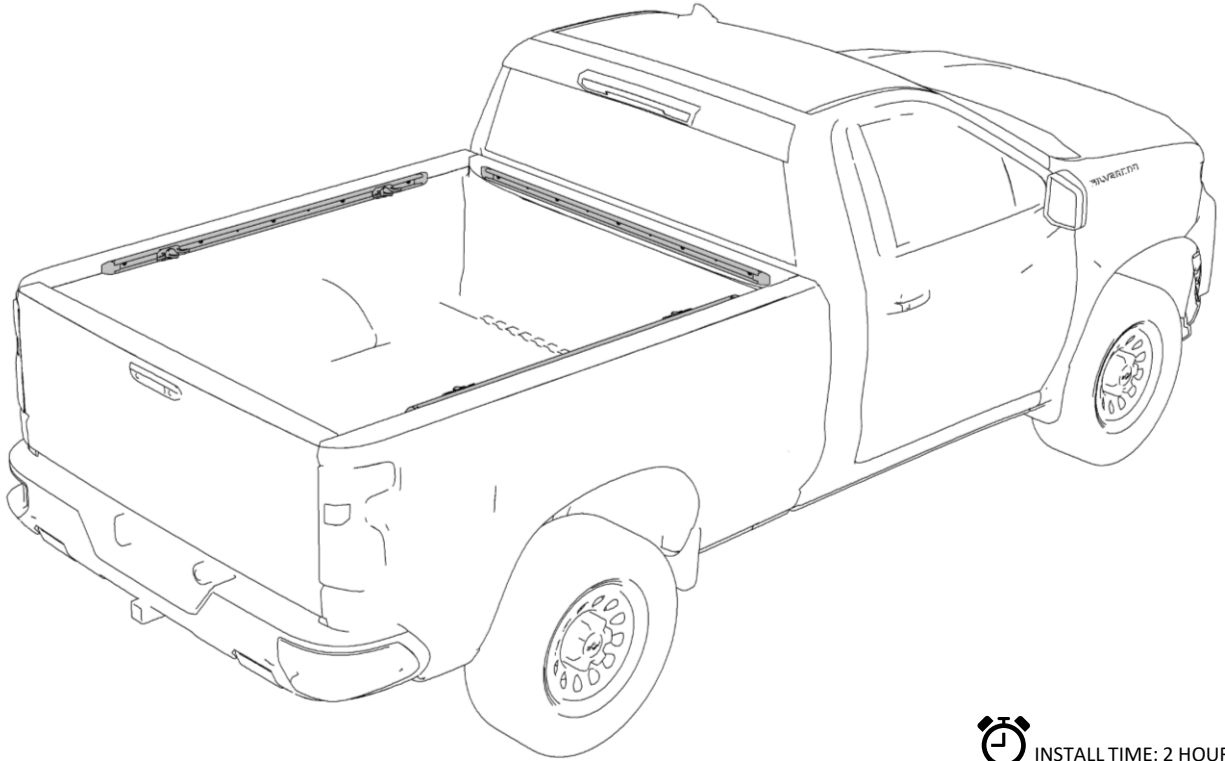



ApexOEM

32192-CARGO RAILS / STANDARD, SHORT BED



 INSTALL TIME: 2 HOURS

PARTS LIST

ITEM	QTY.	DESCRIPTION	PART NO.
1	4	TIE DOWN	3219-100
2	6	END CAP	3219-1001
3	3	56" RAIL	32192-1000
4	10	¼" SQUARE WASHER	
5	15	¼" FLAT WASHER	
6	10	¼"-20 NYLON INSERT LOCK NUT	
7	15	¼"-20 X 1" BUTTON HEAD SCREW	
8	5	¼"-20 RIVET NUT	
9	1	RIVET NUT INSTALL TOOL	3219-200

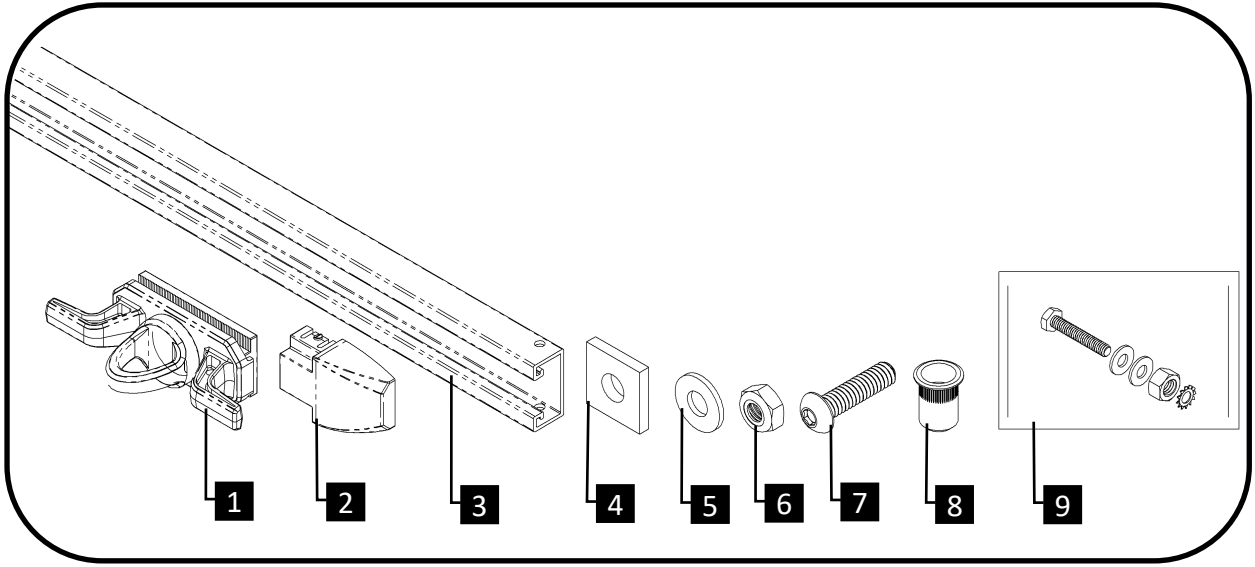

TOOLS REQUIRED

A	DRILL
B	5/16" DRILL BIT
C	25/64" DRILL BIT
D	TAPE MEASURE
E	5/32" ALLEN KEY
F	7/16" WRENCH
G	9/16" WRENCH
H	7/16" SOCKET
I	RATCHET
J	C-CLAMP

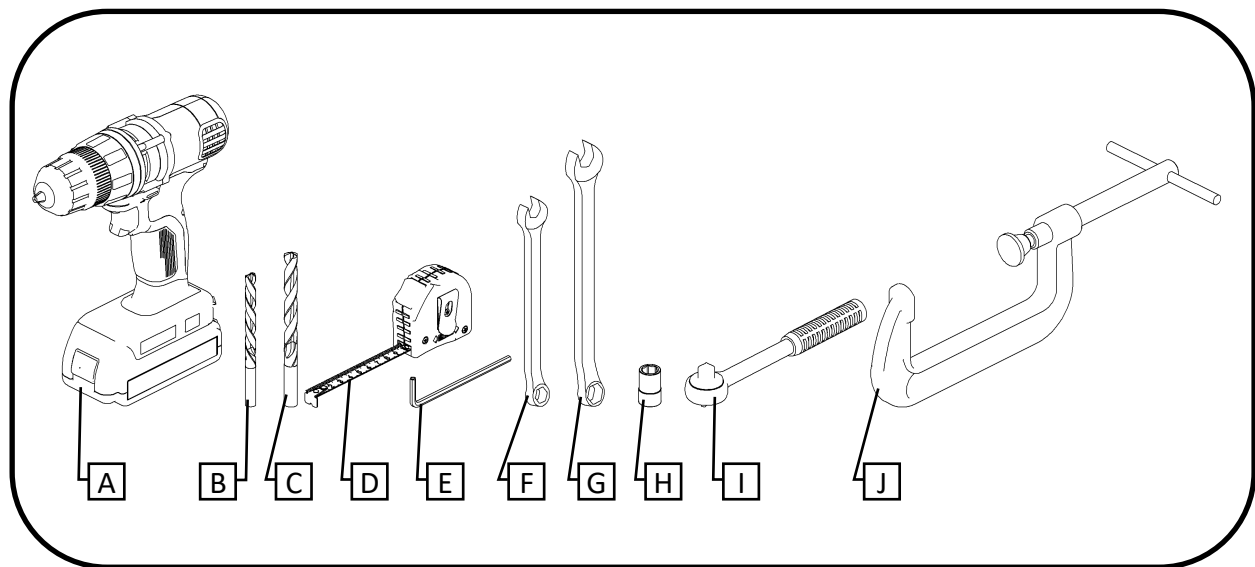

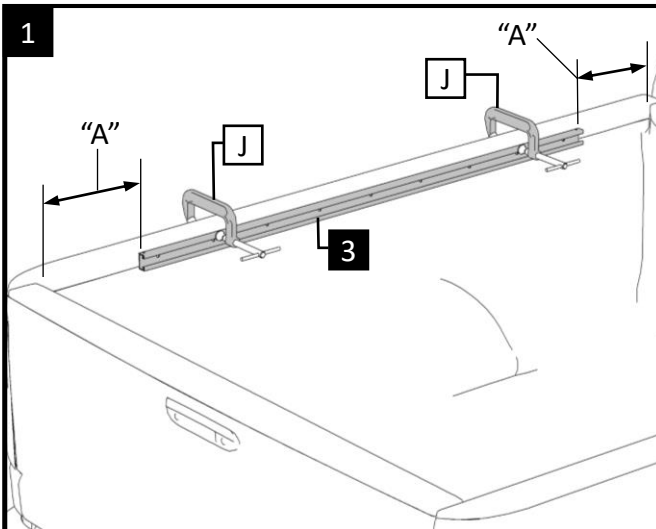

MEASUREMENT "A" AND "A" TO BE EQUAL.

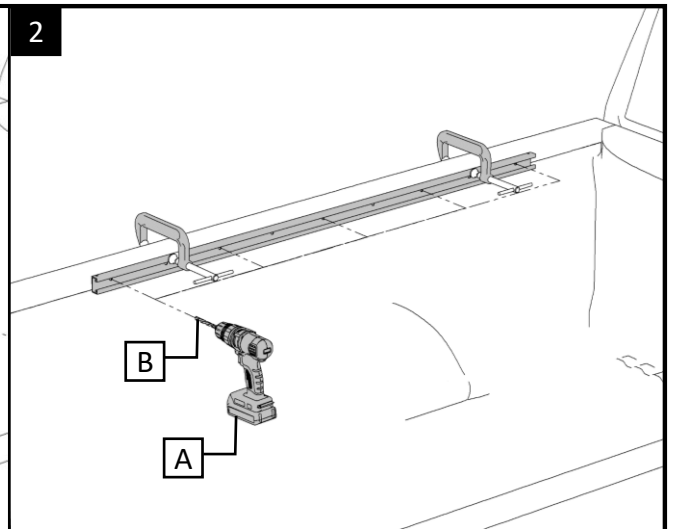

DRILL FIVE HOLES USING 5/16" DRILL BIT, MAKING SURE TO HAVE CLEAR ACCESS ON BACK SIDE.

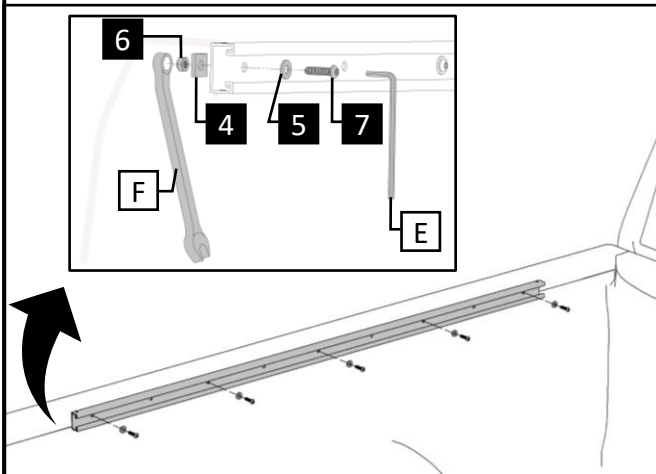

INSTALL SIDE RAIL USING 5/32" HEX KEY AND 7/16" WRENCH.

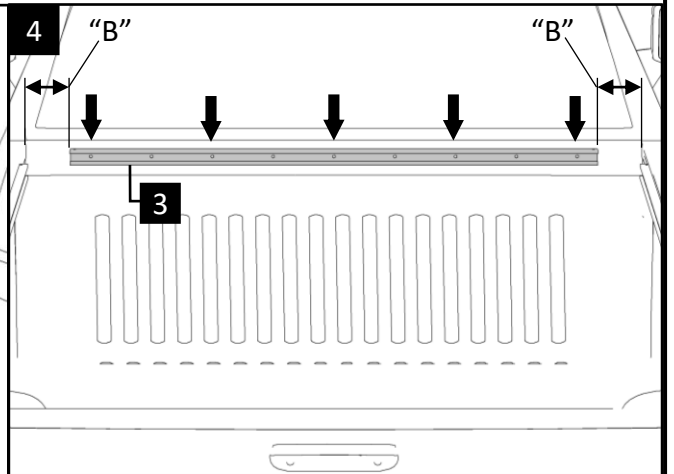

MEASUREMENT "B" AND "B" TO BE EQUAL. MARK NOTED HOLES.

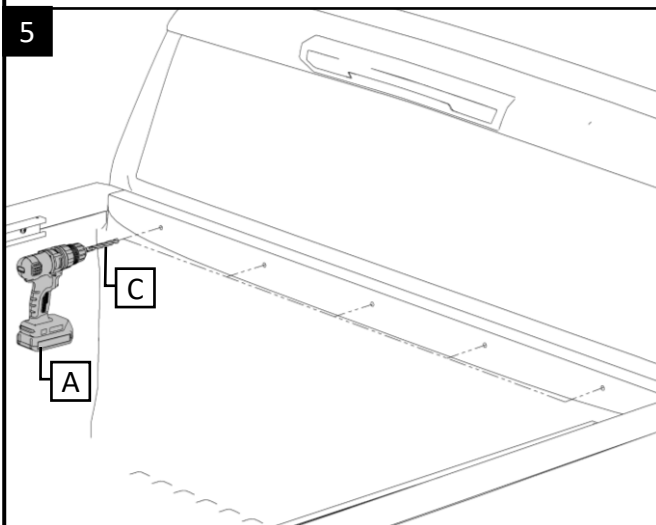

DRILL MARKED HOLES USING 25/64" DRILL BIT.

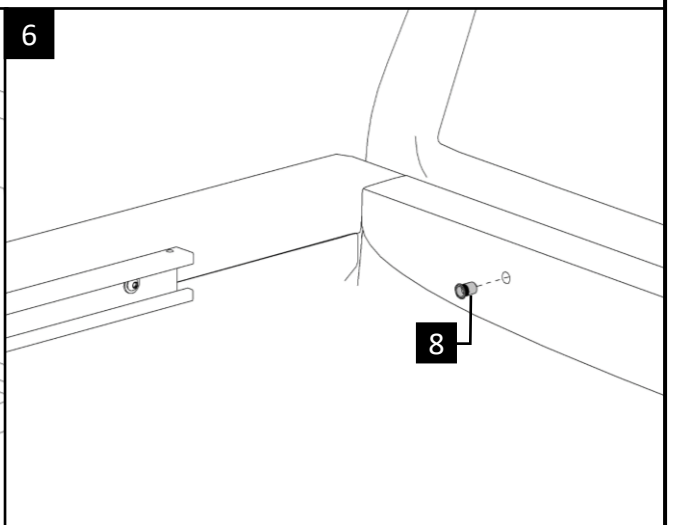

INSERT RIVET NUT INTO 25/64" HOLE.

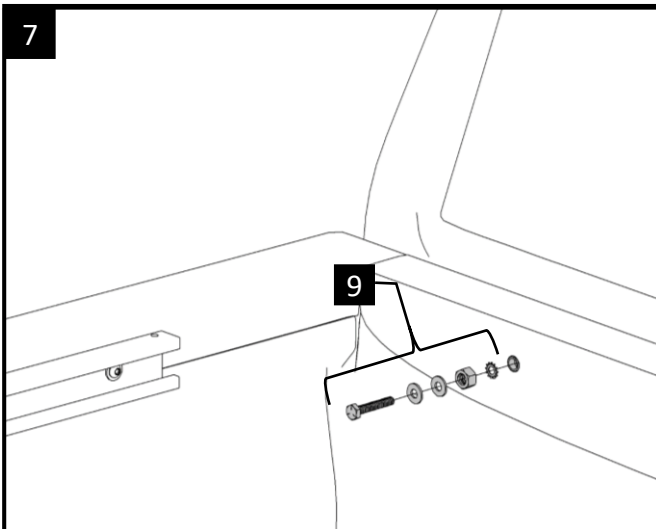

7
INSERT RIVET NUT INSTALLATION KIT COMPONENTS IN ORDER SHOWN.

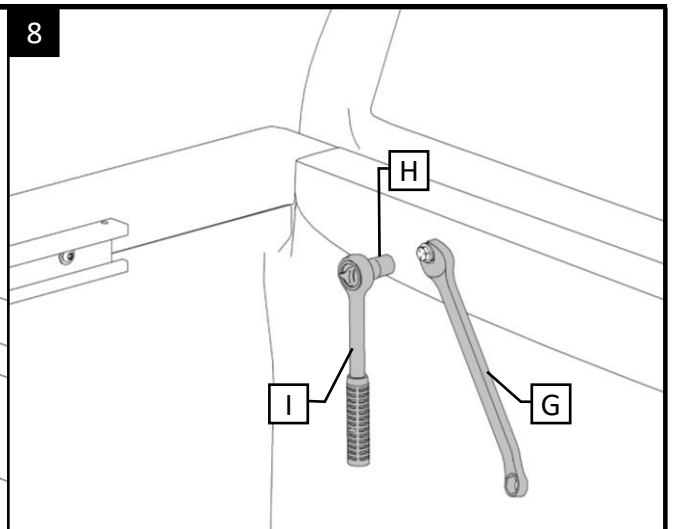

8
SECURELY HOLD HEX NUT USING 9/16" WRENCH.

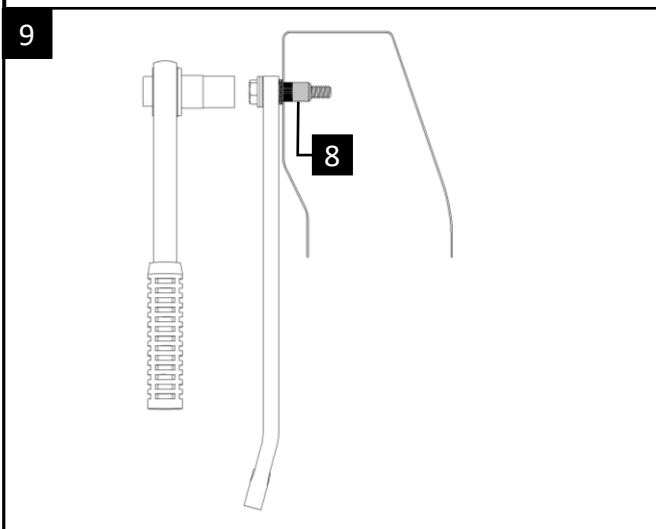

9
SECURELY HOLD HEX NUT USING 9/16" WRENCH.

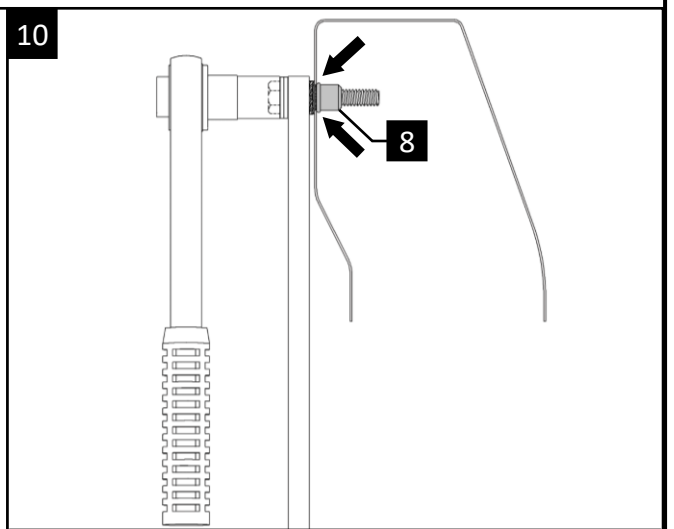

10
TIGHTEN HEX SCREW USING 7/16" SOCKET UNTIL RIVET NUT IS FULLY COLLAPSED.

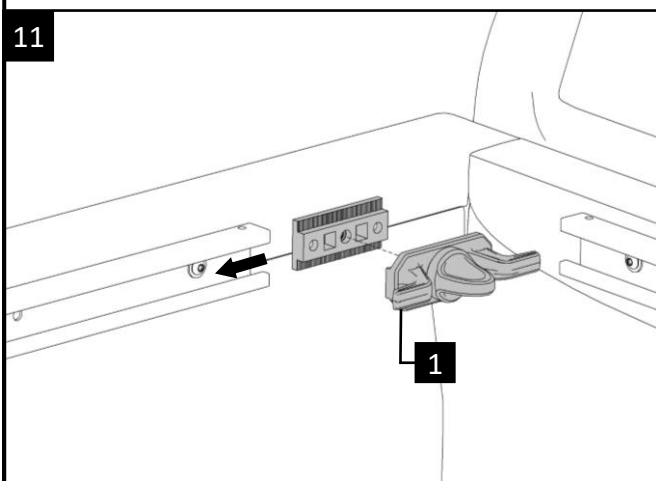

11
INSERT SLIDE NUT INTO RAIL.

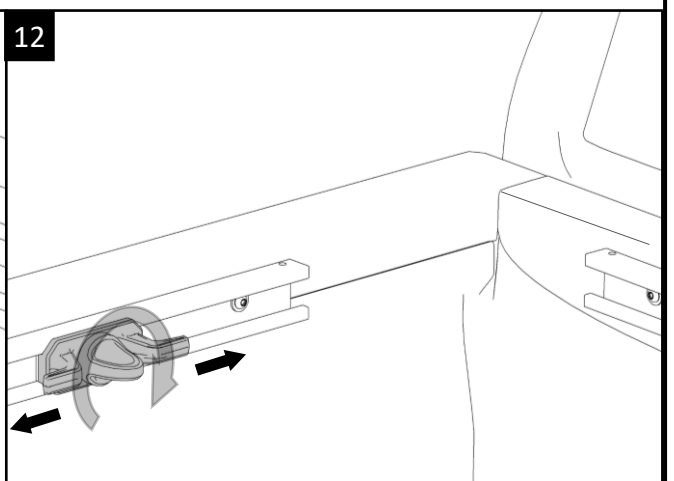

12
SLIDE TIE DOWN TO DESIRED LOCATION. TURN CENTER LOOP CLOCKWISE TO LOCK IN PLACE.

13

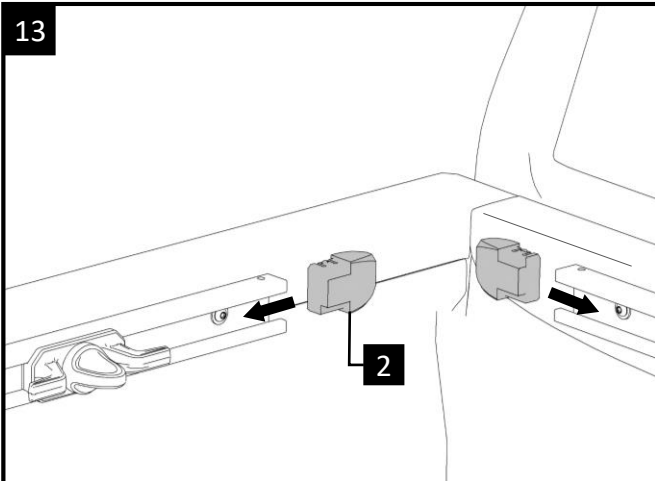

14

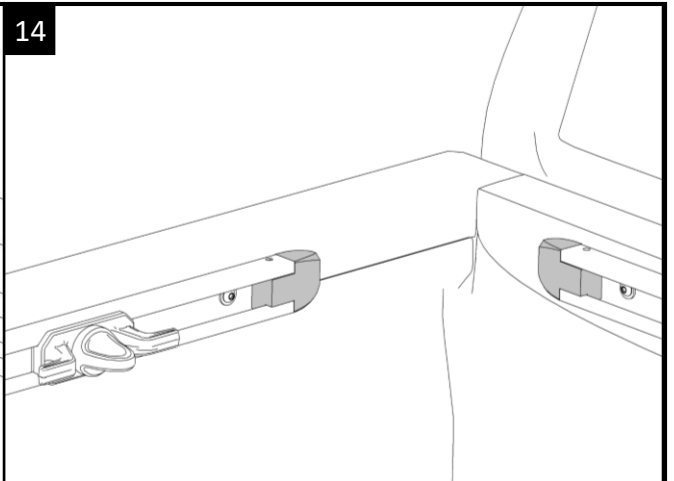

INSERT END CAPS INTO RAILS.

INSTALLATION COMPLETE.