

# cepa

buffet / buffet / *buffet*

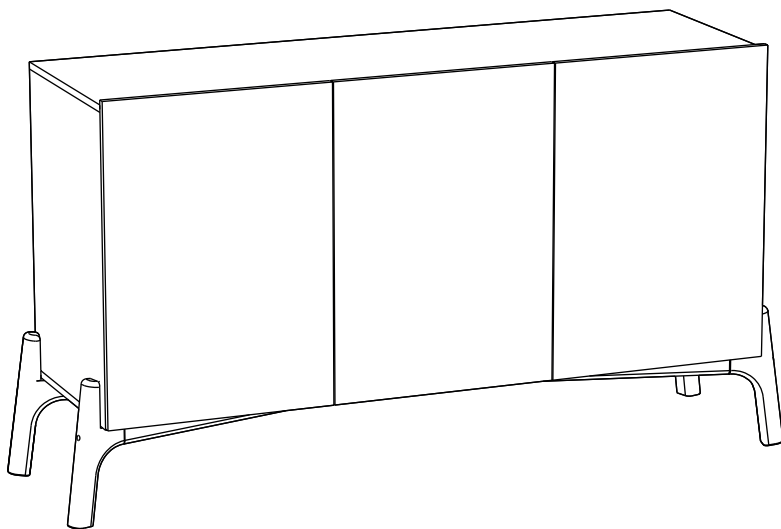

veromobili

feito **com amor** no brasil





Leia atentamente as instruções antes de montar seu novo móvel preferido!

¡Lea atentamente las instrucciones antes de montar su nuevo mueble favorito!

*Read the instructions carefully before assembling your new favorite furniture!*

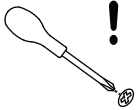

A Veromobili disponibiliza uma chave Philips para vc realizar a montagem com segurança!

La Veromobili te ofrece una llave Philips para que realices el montaje de forma segura.

*The Veromobili offers a Philips key for you to carry out the assembly safely!*

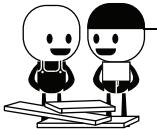

Peça a um amigo para te ajudar nesta montagem. Fica mais fácil e divertido em boa companhia!

Pídale a un amigo que le ayude con esta montaje. ¡Es más fácil y divertido en buena compañía!

*Ask a friend to help you with this setup. It is easier and more fun in good company!*



Realize a montagem sobre um tapete ou pano para não estragar ou arranhar o acabamento!

¡Realice el montaje sobre una alfombra o paño para evitar dañar o rayar el acabado!

*Perform the assembly on a carpet or cloth to not damage or scratch the finish!*



Tenha atenção para a posição correta de cada peça. Posiciona-las invertidas pode prejudicar a estabilidade e segurança do seu móvel!

Presta atención a la posición correcta de cada pieza. ¡Colocarlos invertidos puede poner en peligro la estabilidad y seguridad de sus muebles!

*Pay attention to the correct position of each piece. Positioning them inverted can jeopardize the stability and security of your furniture!*

**A1.** x2



**A2.** x2



**B1.** x1

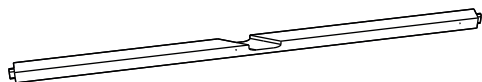

**B2.** x1

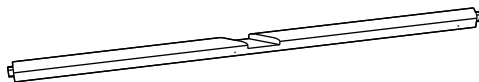

**C1.** x1

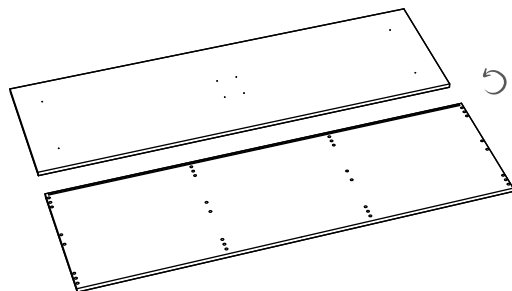

**C2.** x1

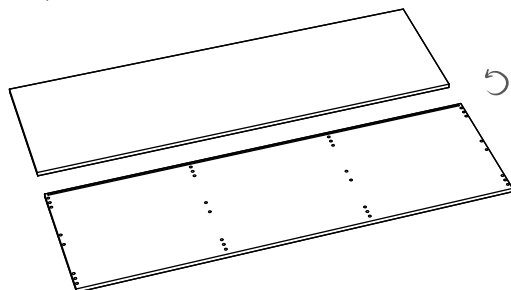

**D1.** x1

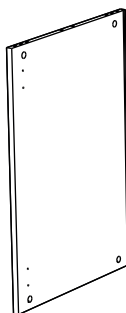

**D2.** x1

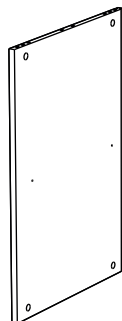

**D3.** x1

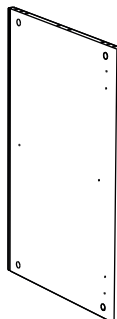

**D4.** x1

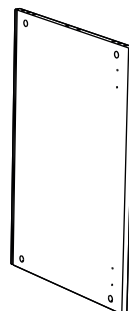

**E1.** x2

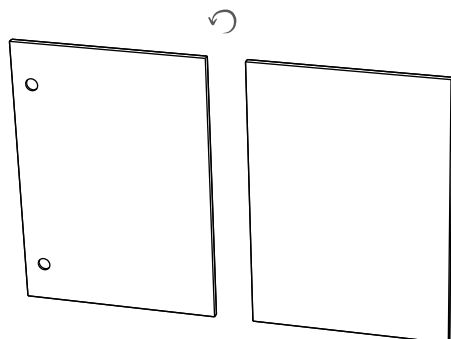

**E2.** x1

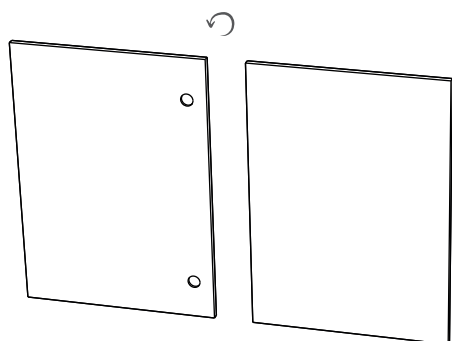

**F.** x1

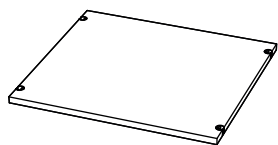

**G1.** x1

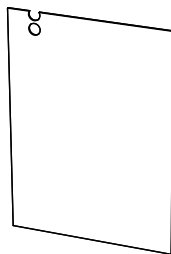

**G2.** x1

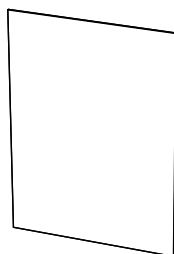

**G3.** x1

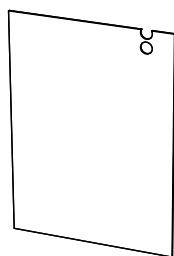

# Ferragens

Herrajes  
Hardware



**1.** x4 Parafuso 5,5x65



**2.** x8 Parafuso 4x25 Flangeado

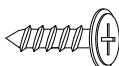

**3.** x8 Parafuso 4x14 Flangeado



**4.** x8 Cantoneira



**5.** x48 Cavilha



**6.** x16 Haste Rodofix



**7.** x16 Tambor Rodofix



**8.** x4 Parafuso 6x10 Chamfrado

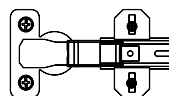

**9.** x6 Dobradiça



**10.** x4 Suporte prateleira

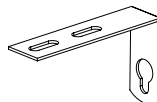

**11.** x2 Cantoneira L

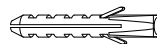

**12.** x2 Bucha 6mm



**13.** x2 Arruela



**14.** x2 Parafuso 5x40

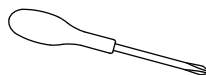

x1 Chave Philips

kit dispositivo de segurança

# Vista explodida

Explosión  
*Exploded view*

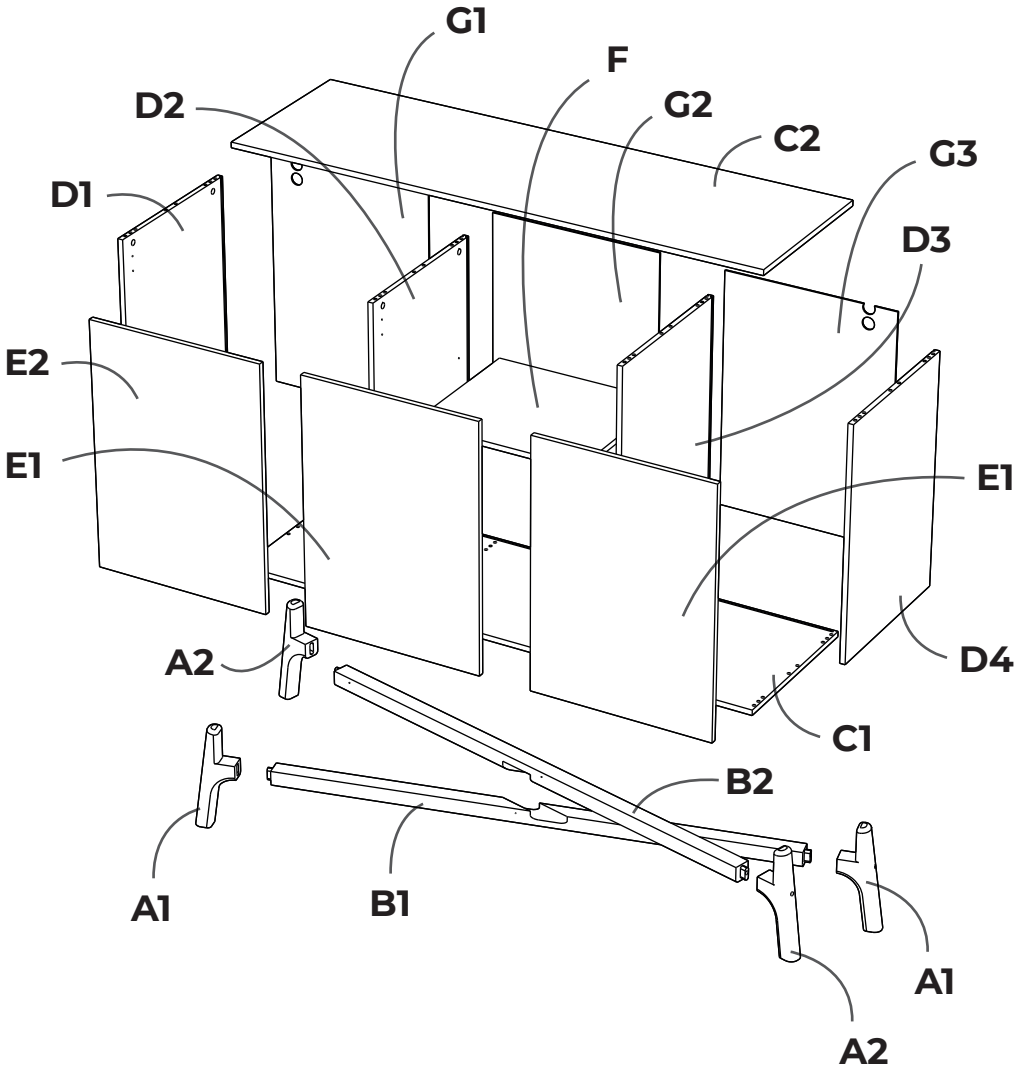

I.

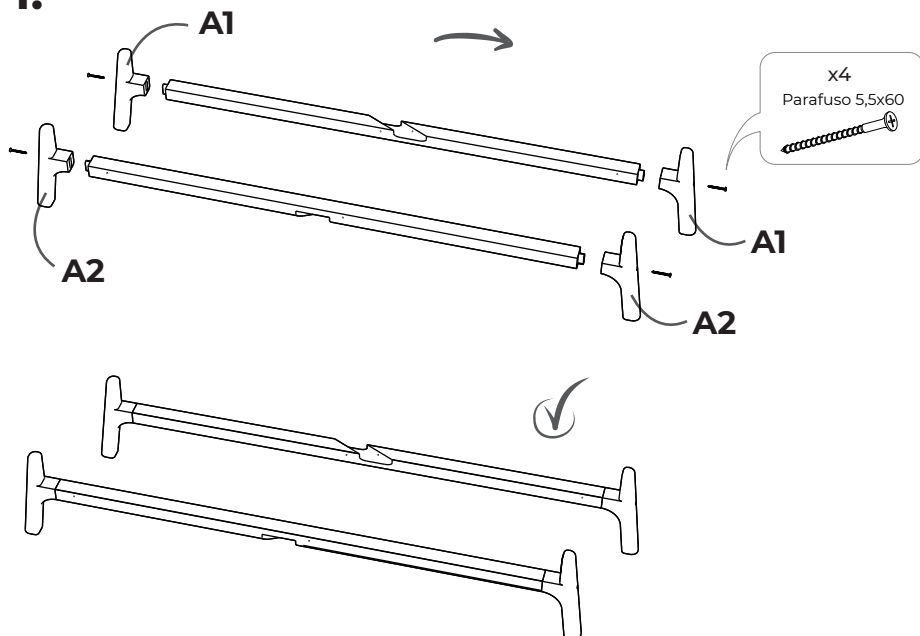

II.

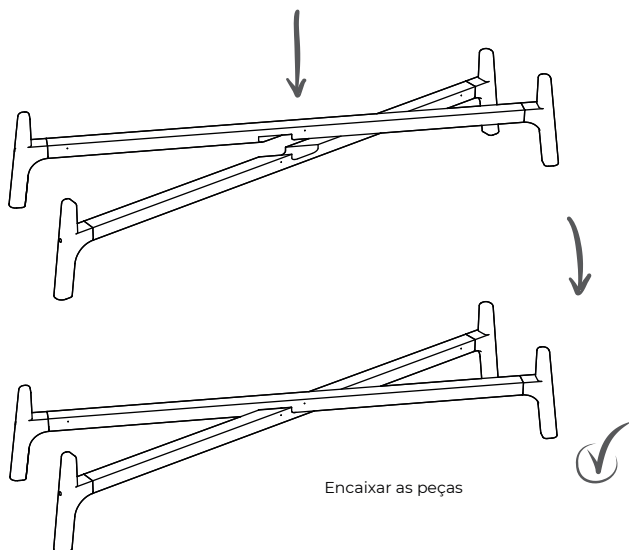



III.

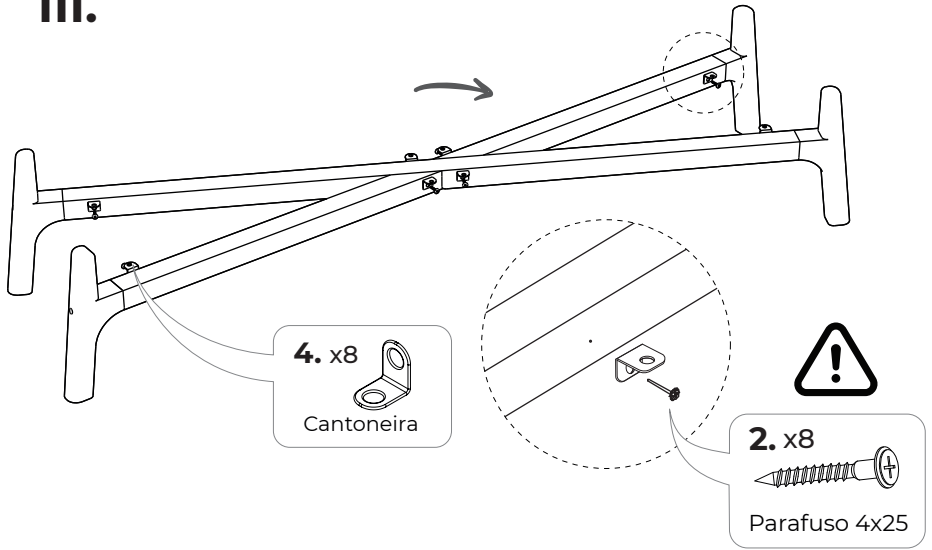

IV.

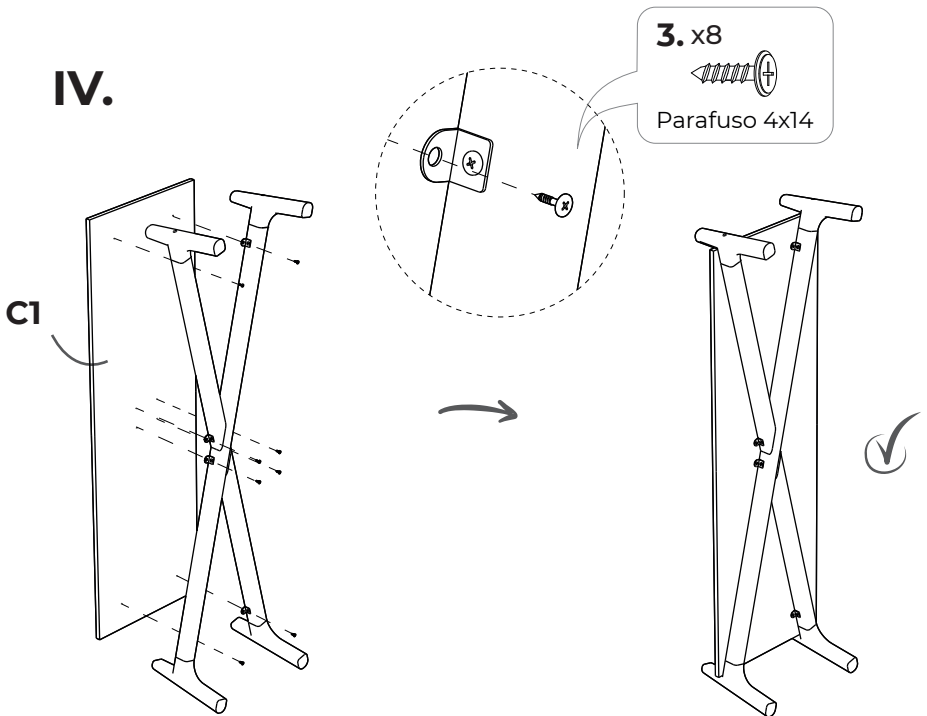

V.

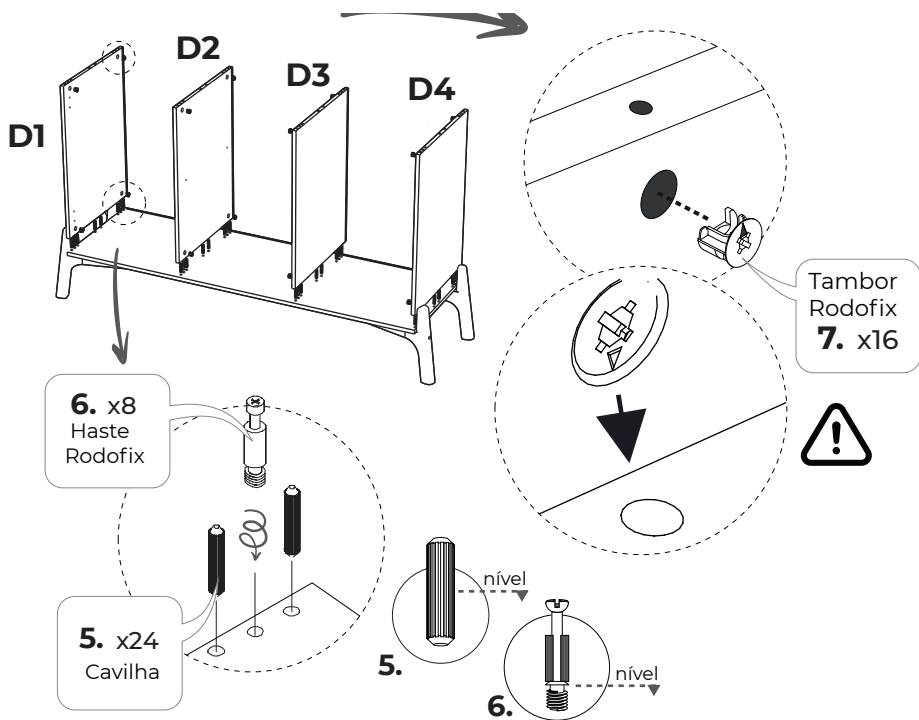

VI.

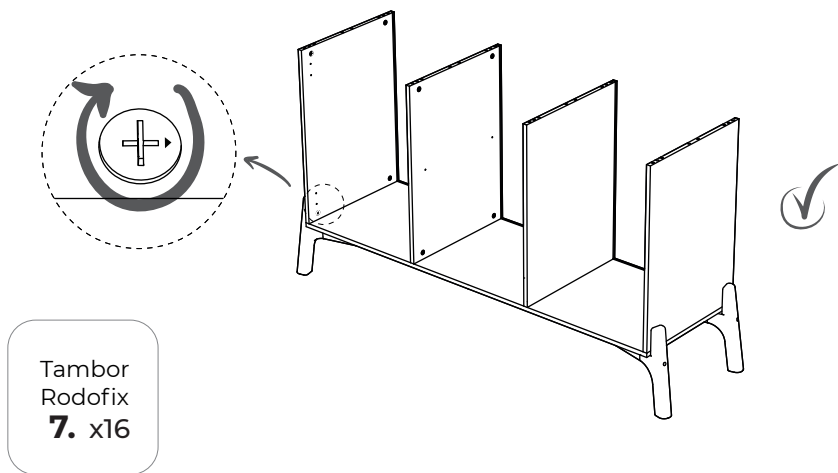

## VII.

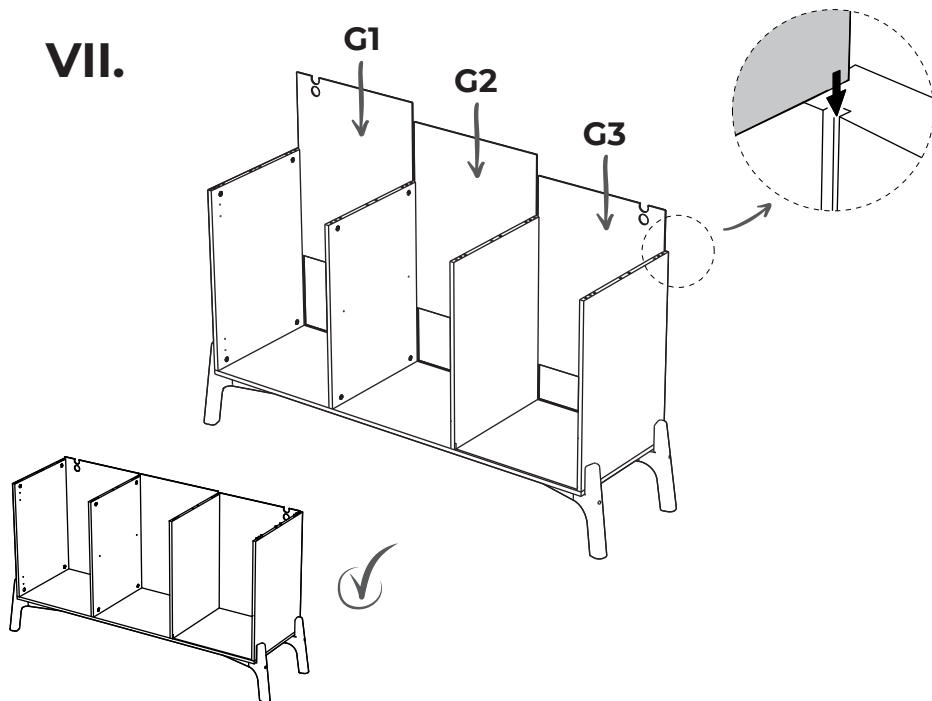

## VIII.

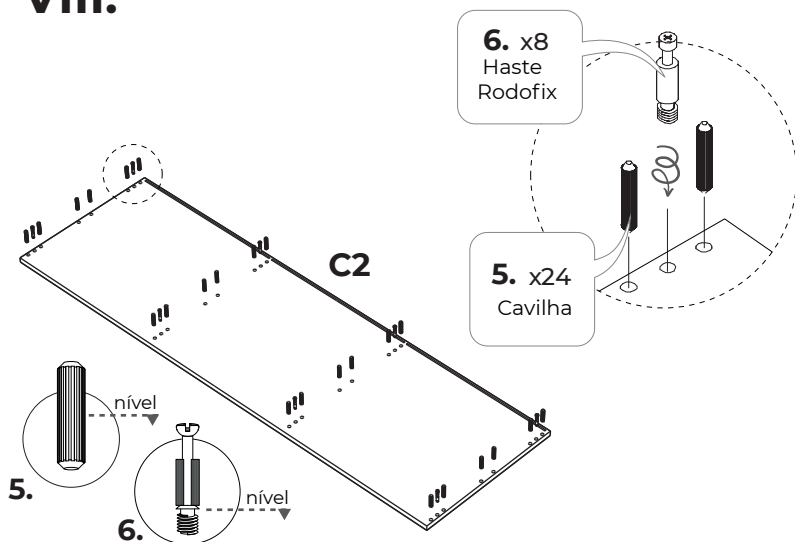

**IX.**

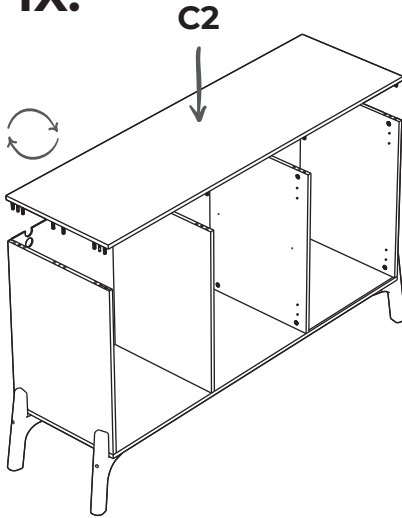

Tambor  
Rodofix  
**7. x16**

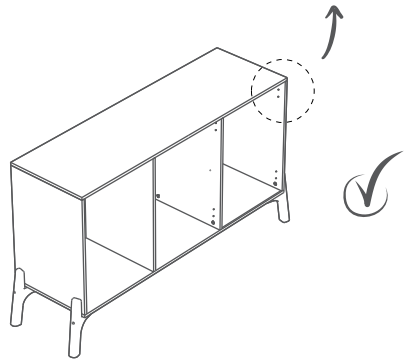
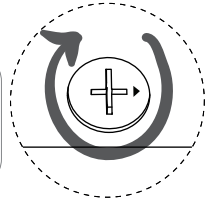

**X.**

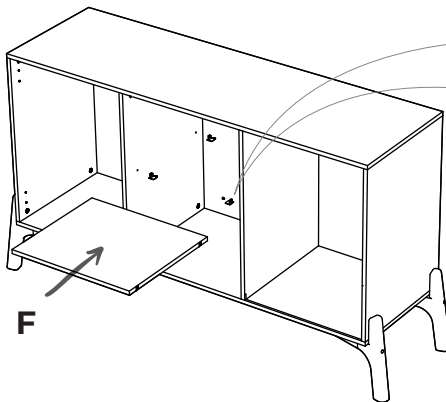

**8. x4**  
Parafuso 6x10  
Chanfrado



Suporte  
prateleira **10. x4**

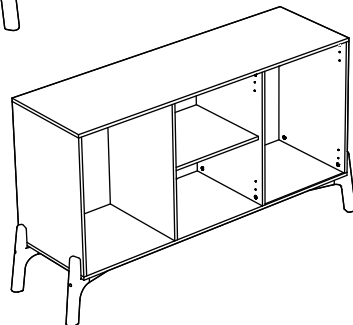

# XI.

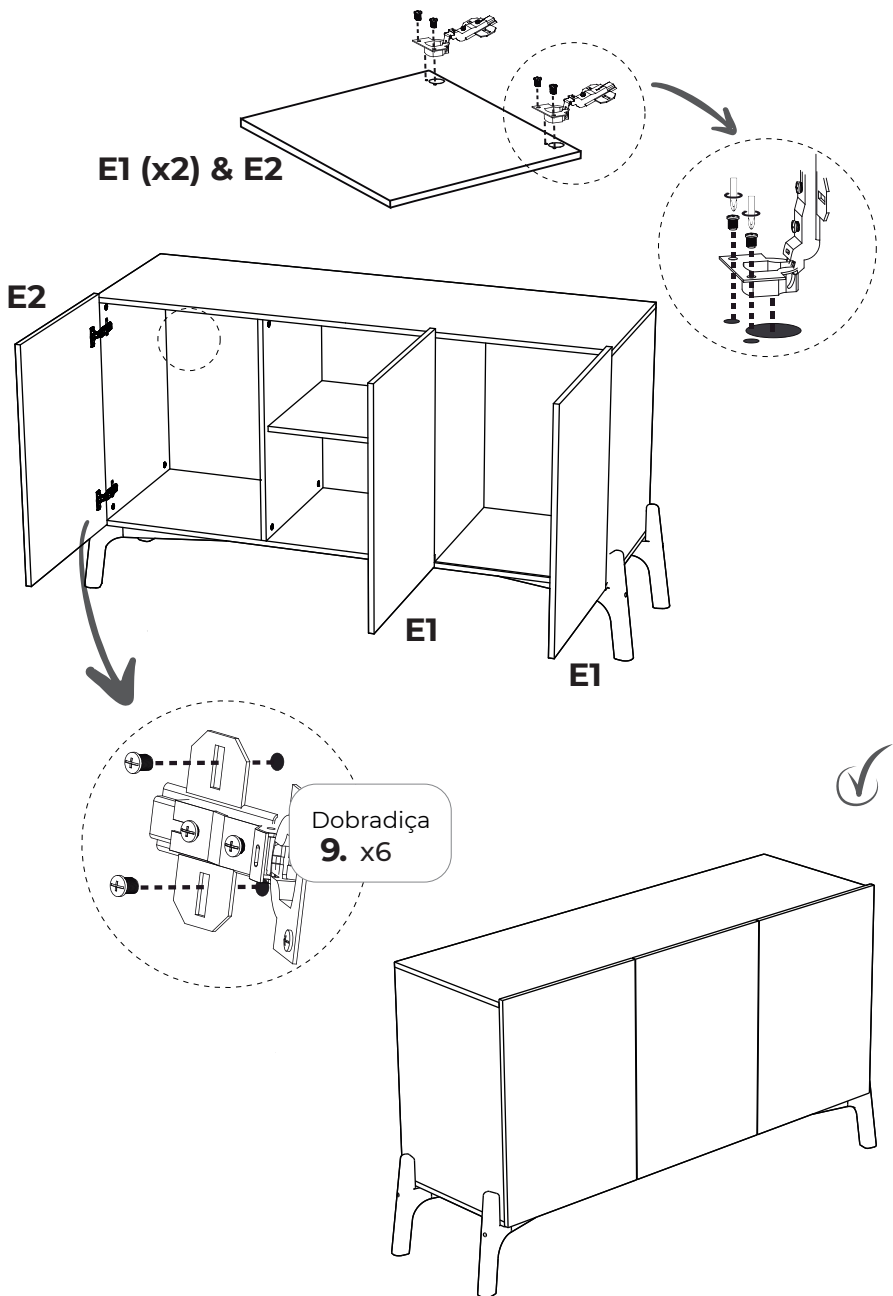

## PARA AJUSTAR A DOBRADIÇA

Caso a porta não esteja 100% alinhada, é bem simples arrumá-la: basta Desparafusar os parafusos de modo que eles fiquem meio soltos, arrumar a porta e, então, parafusar os parafusos novamente.

## PARA AJUSTAR LA BISAGRA

Si la puerta no está 100% alineada, es bastante simple arreglarlo: basta con desatornillar los tornillos para que están un poco flojos, se acomoda la puerta nuevamente y luego vuelva a enroscar los tornillos.

## TO ADJUST THE HINGE

If the door is not 100% aligned, it's quite simple to fix it: just unscrew the screws so that they are a little loose, place the door again and then screw the screws back in.

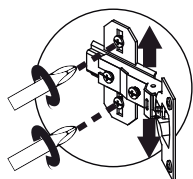

Alinha altura da porta com a furação da lateral  
Alinea la altura de la puerta con el orificio del lateral  
Align the height of the door with the hole on the side

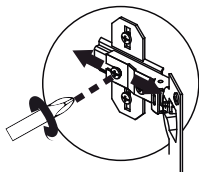

Alinha largura da porta com a furação da lateral  
Alinea el ancho de la puerta con el agujero en el lateral  
Align the width of the door with the hole in the side

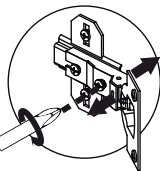

Alinha profundidade da porta com a furação da lateral  
Align the depth of the door with the hole in the side  
Alinea la profundidad de la puerta con el agujero en el lateral

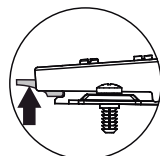

Para tirar a dobradiça, basta puxar essa parte detrás  
To remove the hinge, just pull this part back.  
Para quitar la bisagra, simplemente tire de esta parte hacia atrás.

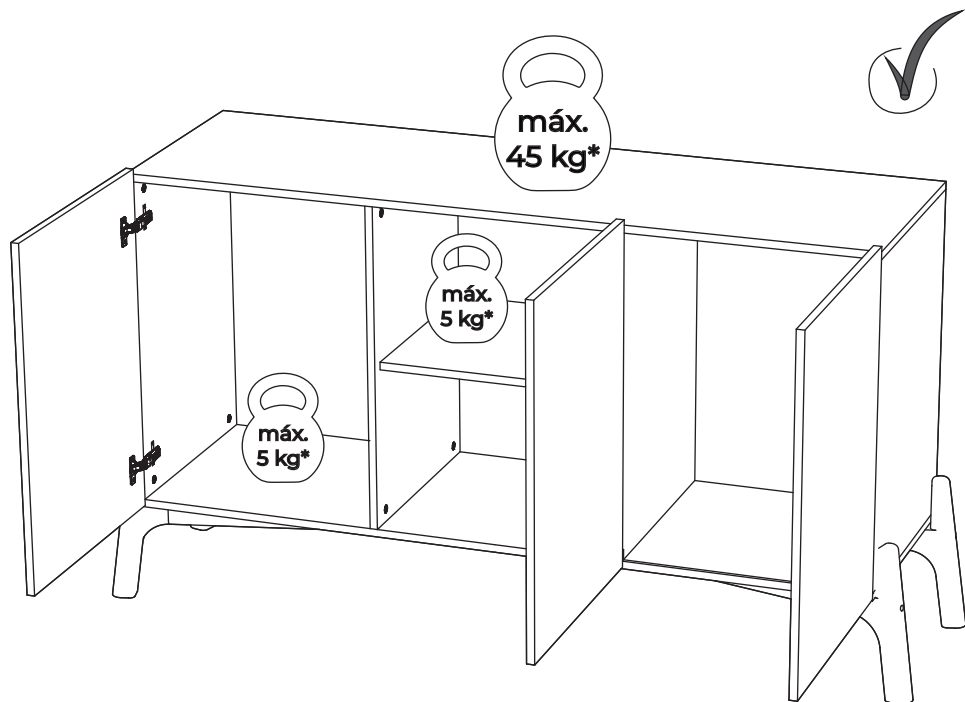

\* Peso máximo por prateleira distribuído uniformemente na superfície.

\* Peso máximo por estante distribuidos uniformemente en la superficie.

\* Maximum weight per shelf evenly distributed on the surface.



## Dispositivo de segurança

Dispositivo de seguridad

Safety device

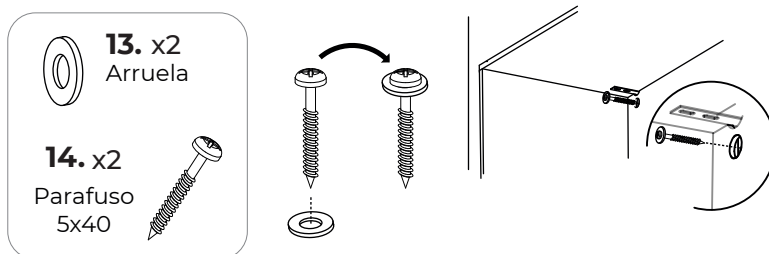
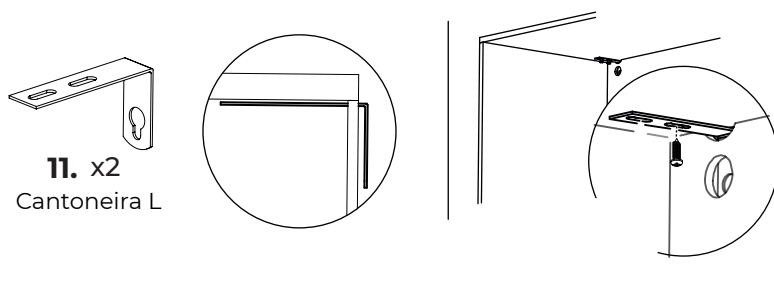
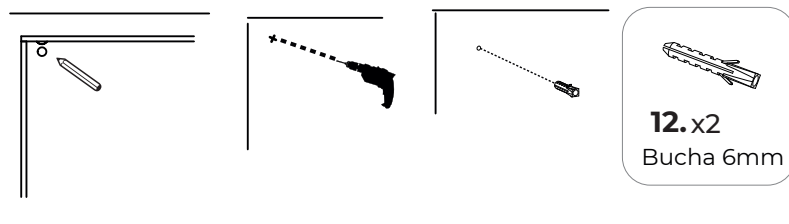
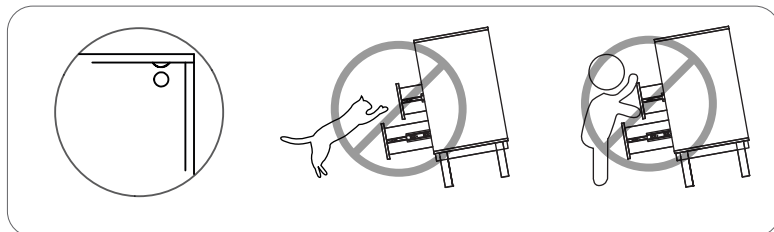





## Cuide bem do seu Veromobili!

Cuida bien de tu Veromobili!

*Take good care of your Veromobili!*

### Limpeza

Madeira.

Utilize apenas produtos neutros e panos brancos levemente umedecidos para a limpeza. Nunca utilize produtos abrasivos.



Dobradiças e Corrediças.

Para as dobradiças e corrediças, utilize pano seco ou um pincel macio para retirar a poeira.

### Limpieza

Madera.

Utilice únicamente productos neutros y paños blancos ligeramente humedecidos para la limpieza. Nunca use productos abrasivos.

Bisagras y brazos corredizos.

Para bisagras y guías, use un paño seco o un cepillo suave para quitar el polvo.

### Cleaning

Wood.

Use only neutral products and lightly moistened white cloths for cleaning. Never use abrasive products.

Hinges and sliders.

For hinges and slides, use a dry cloth or a soft brush to remove dust.

---

### Contato

Em caso de dúvidas, ligue pra gente. Ficaremos felizes em te ajudar!

### Contacto

En caso de duda, llámanos. ¡Estaremos encantados en ayudarte!

### Contato

*If in doubt, call us. We will be happy to help you!*



contato@veromobili.com.br  
veromobili@veromobili.com.uy (Uruguay)



<https://www.veromobili.com.br/fale-conosco/>  
<https://www.veromobili.com.uy/contacto/> (Uruguay)



Siga,  
Curta,  
Compartilhe!

**#meuVero**  
**#miVero**

@veromobili