

Dorian

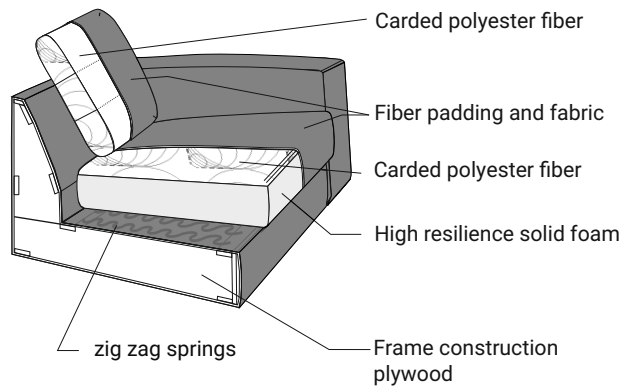

Comfort



Extra dimensions

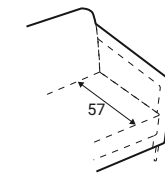

depth of seat

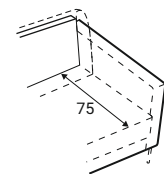

depth of seat without back cushions

Legs

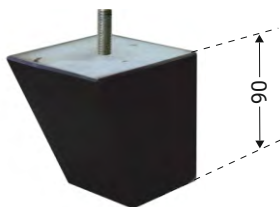

Leg W-25, H-90
Solid wood, painted black

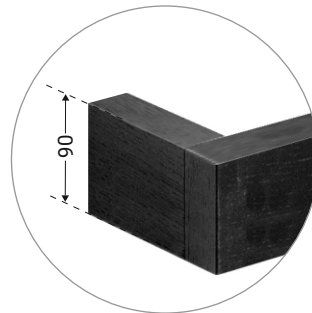

Leg W-34, H-90
MDF, painted black

Accessories

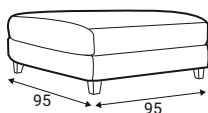

Footstool 95x95

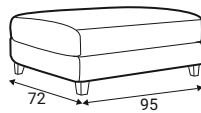

Footstool 72x95



Dorian

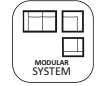

Standard sets

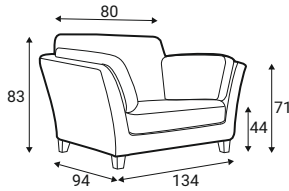

1S - seater

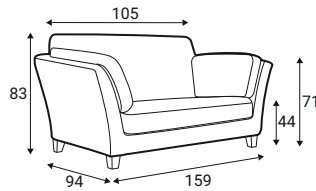

1,5S - seater

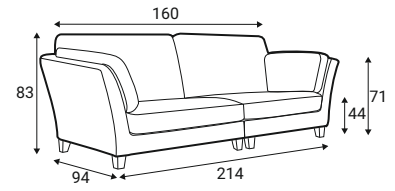

2S - seater

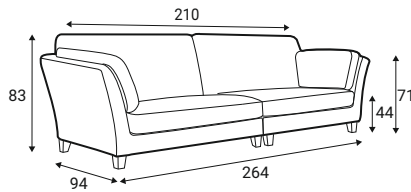

3S - seater

Modules

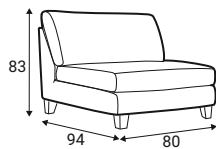

80 - middle

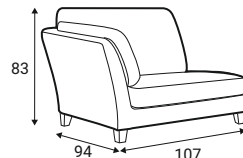

80L - left

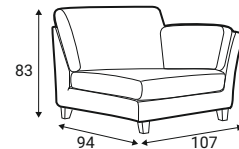

80R - right

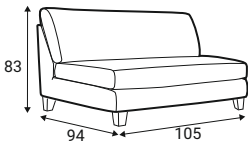

105 - middle

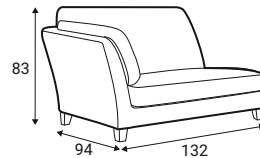

105L - left

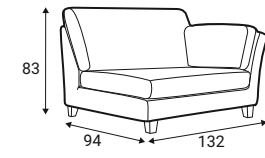

105R - right

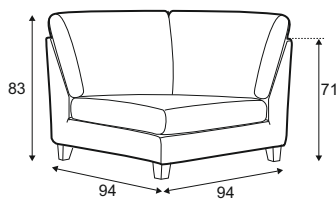

C1 - corner

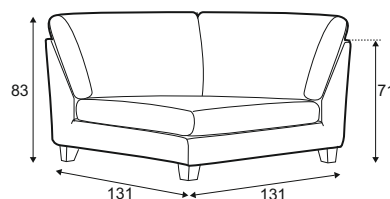

C2 - corner



Dorian



Modules

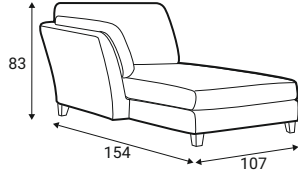

D80L - left

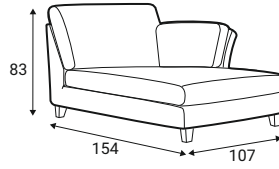

D80R - right

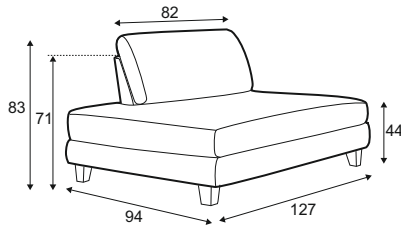

OEL - left

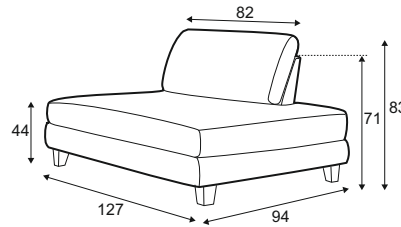

OER - right

Furniture features in symbols



- Seat and back cushions are loose from the frame.



- Fabric



- Removable cover for loose cushions.
(For maintenance please check fabric information.)



- Modular system