

Installation Guide and Support Manual

PHOENIX

Phase Converters

GP7PL



VER 1.1.0



GENERAL SPECIFICATIONS	
HP	7.5
KW	5.6
KVA	6.51
HZ	50/60
ENCL	TEFC/NEMA 4
FRAME	213T
IDLER WEIGHT	158.76
PANEL WEIGHT	21

CONSTRUCTION, DIMENSIONS, WEIGHT	
ELECTRICAL PANEL	
ENCLOSURE TYPE	NEMA 4
ENCLOSURE CERTIFICATIONS	UL 508A (CSA C22.2 No. 14-13.), TUV, CE.
COLOR	Light Gray
HEIGHT	20
WIDTH	12
DEPT	8
MOUNTING	Wall Mount

SINGLE PHASE ELECTRICAL SPECS	
VOLTAGE INPUT	208-250V
MOTOR LOAD BREAKER Minimum Size	15
MOTOR LOAD BREAKER Maximum Size	40
SERVICE KVA Minimum Size	15
SERVICE AMPS Minimum Size	60
COPPER WIRE Minimum Size	6

THREE PHASE ELECTRICAL SPECS	
VOLTAGE OUTPUT	208-230 Volts Delta
MAX OUTPUT INDUCTIVE LOAD AMPS	21
MAX OUTPUT RESISTIVE LOAD AMPS	10
VOLTAGE BALANCING	+/- 2%
WIRE SIZE MIN Idler/Generator	8
LARGEST SPINDLE MOTOR START	3
LARGEST COMPRESSOR LOAD START	2
TOTAL COMBINED HORSEPOWER RUN	7.5

Optional Feature

- 208, 460 Volt Output (includes transformer)
- AutoStart and AutoOff with load detection
- PL Model (includes Start and Stop with Built-in Mag Starter)
- GPX Model (includes WFI Cloud Controls, Timers, Energy Monitor)
- Wireless Remote ON/OFF

PHOENIX PHASE CONVERTERS

800-417-6568

CAUTION

READ INSTRUCTIONS BEFORE OPERATING

READ FIRST - BEFORE INSTALLATION

- **Most important step to know.**
- NEVER Start the phase converter with a load, this includes transformers.
- Make sure you have the incoming service to start the phase converter, call your electric company verify the KVA size of the transformer, that KVA number should be larger then the HP of the idler motor.
- **DO NOT use WIRE NUTS for any connection, use the bolt down lugs. Check all make sure all connections even factory connections to the power block are secure, also recheck connections after a few week of using the converter.**
- **When powering up the unit, if the idler does NOT come up to FULL SPEED, then shut the phase converter down right away. If you don't understand then call us or a qualified electrician. if you do not turn the unit off you have a chance to damage the idler motor that will not be covered under warranty.**
- Must be installed by a license industrial electrician, our guidelines are not to supersede local and state laws.

Power requirements

- You will need to use a **motor load** type breaker. NOT a quick blow or instant trip breaker.
- Sizing a breaker for a single machine with an inductive load (motors) double the amps size of the machine. Example if the equipment pulls 20 amps use a 40 amp breaker.
- Sizing the equipment for multiple machine double the amp of the largest machine and add the the other machine that will run at the same time. Example; 20 AMP Lathe. 9 amp saw, 6 amp milling machine. $20 \times 2 = 40 + 9 + 6 = 45$ amps, use the next standard size breaker which would be 50 Amps two pole breaker.
- Use the chart to make sure you don't go over or under the Minimum and maximum size allowed. For rural areas increase the minimum size breaker by 20% Click on the next picture to see this chart.

GP7

WIRE AND BREAKER SIZES

SINGLE PHASE	8 AWG MIN Copper under 50 feet
IDLER MOTOR	10 MIN AWG COPPER
BREAKER/FUSE	20 MIN / 40 MAX

Mounting the Phase Converter Panel

Mount the enclosure first, to a non-vibrating surface, there are two options provided for mounting, next install the back plate with the four nuts provided. Mounting the phase converter panel near the breaker panel is recommended the larger wire is you single phase line, that is best to keep as short as possible. Every 50 feet you will need to increase the size of the single phase wire.

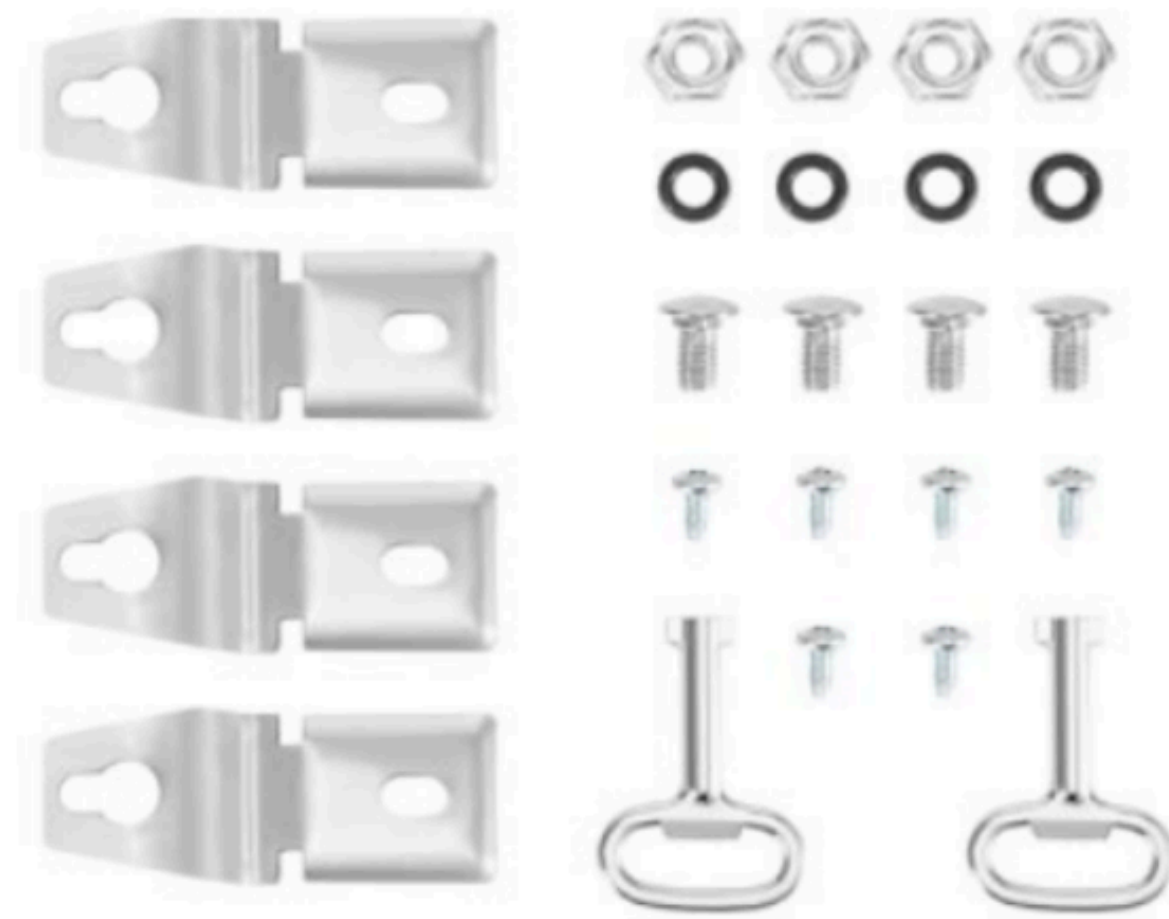

Additional mounting brackets and hardware are inside the enclosure.



Indoor or outdoor enclosure



CONNECTING THE IDLER MOTOR WIRES

THIS IS JUST A ILLUSTRATION OF WHAT WIRES GET CONNECTED TOGETHER, **DO NOT USE WIRE NUTS**, USE BOLT DOWN LUGS

IF YOU HAVE 9 LEADS AT THE MOTOR CLICK HERE

IF YOU HAVE 12 LEADS AT THE MOTOR CLICK HERE

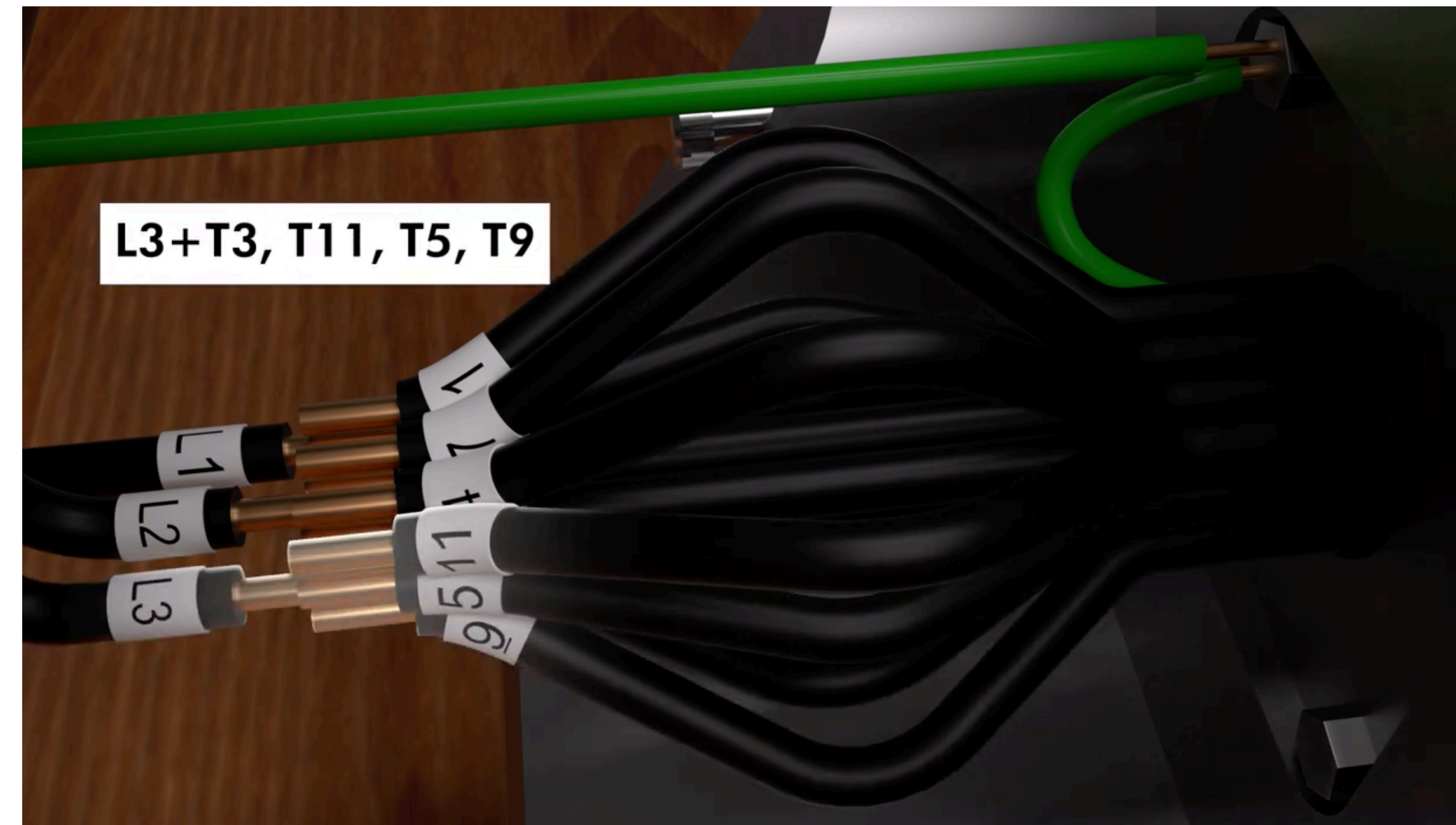

PL AND PH MODELS

MUST BE INSTALLED BY A INDUSTRIAL LICENSED ELECTRICIAN

Motor Load Breaker should be size
Twice the full load amps of your
equipment

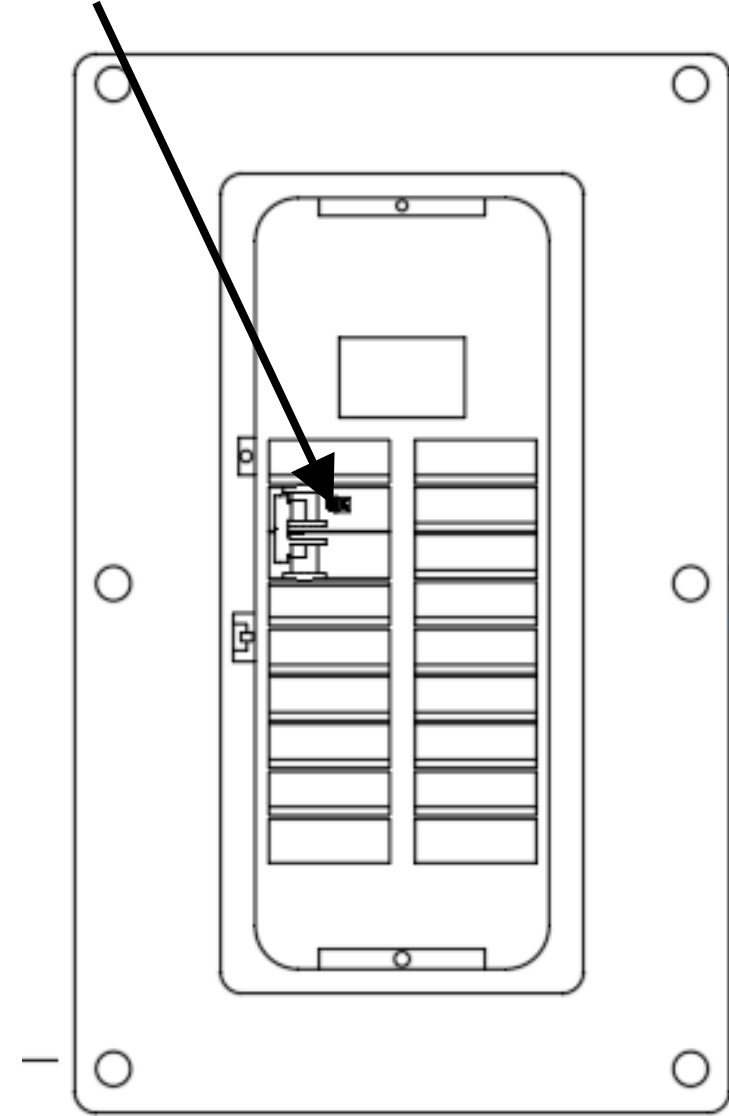

SINGLE PHASE CIRCUIT
BREAKER PANEL

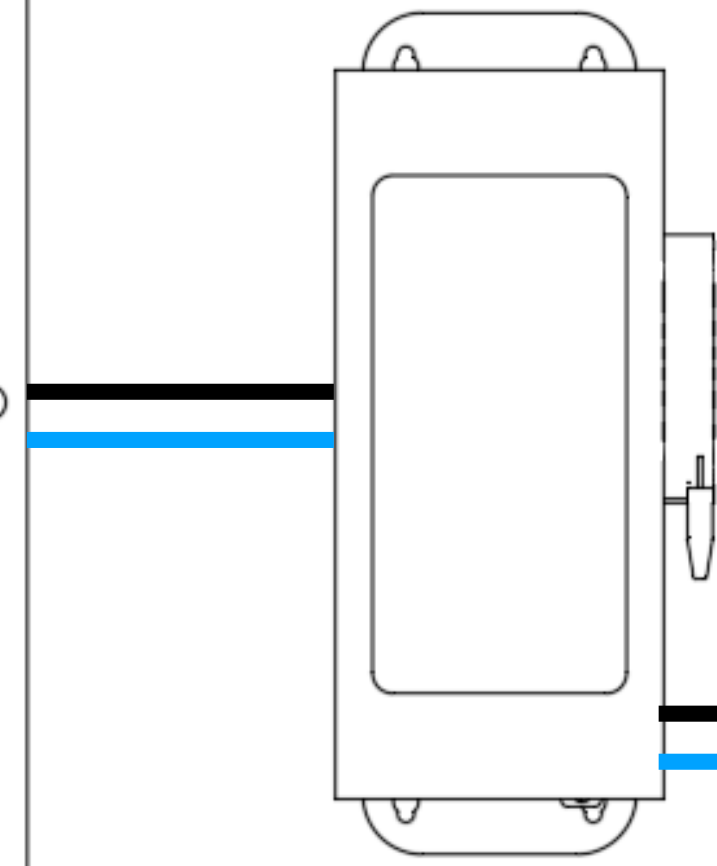

DISCONNECT
SHOULD BE USED
IF YOUR RUN IS
OVER 50 FEET

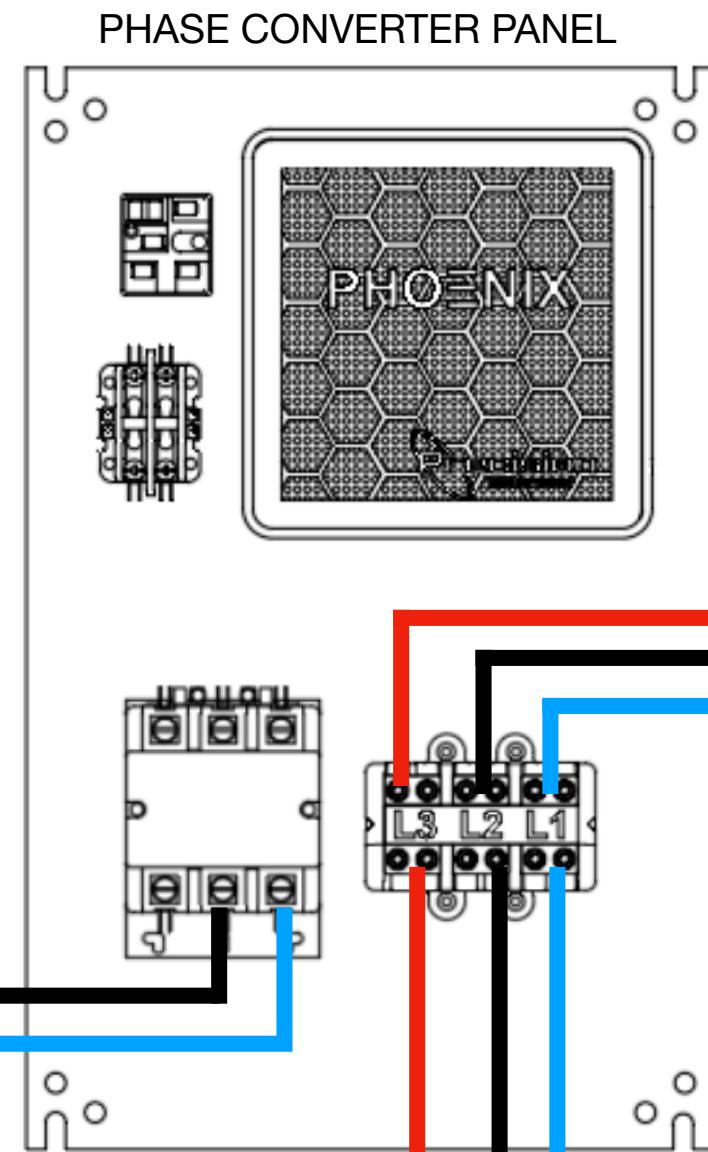

PHASE CONVERTER PANEL

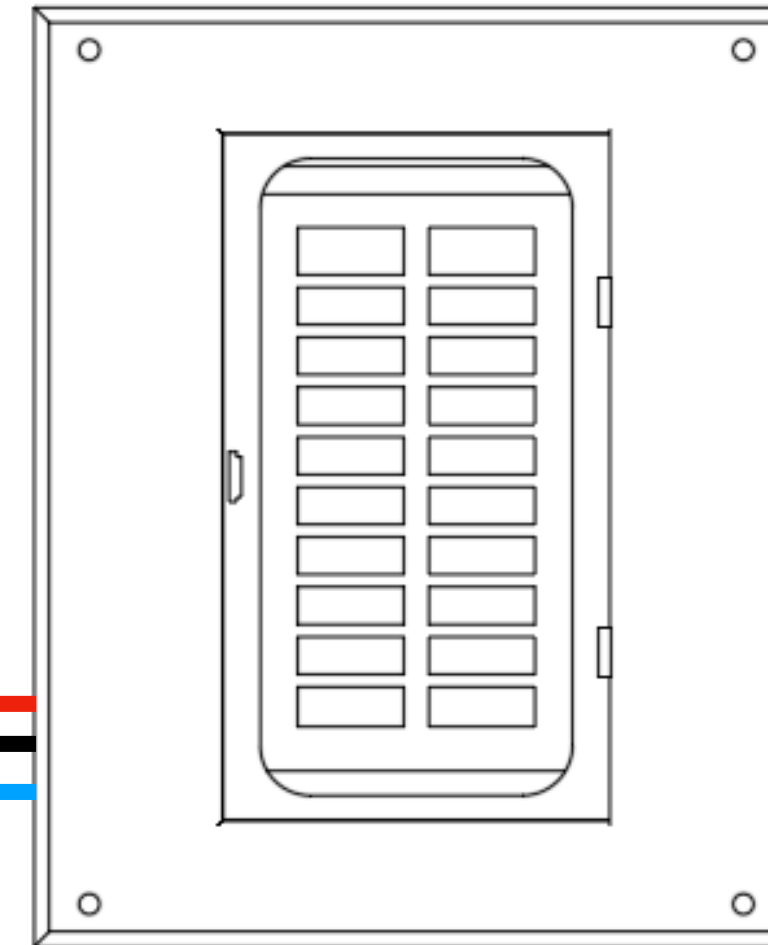

LOAD CENTER,
3PH BREAKER
PANEL, OR
EQUIPMENT

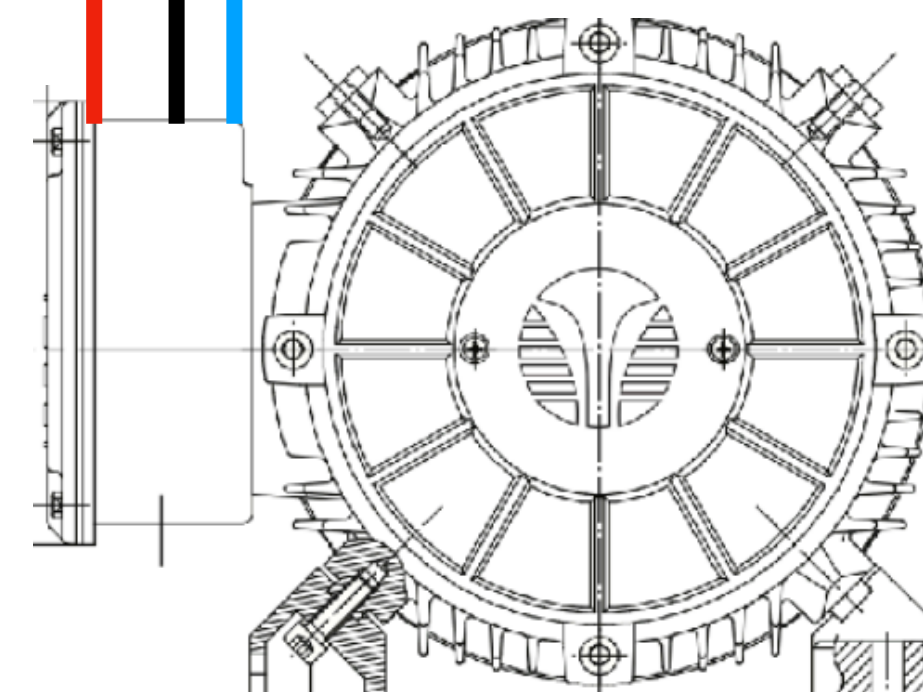

IDLER/GENERATOR
MOTOR

230V Connection for NL and PL Models (low voltage)

460V Connection for NH and PH Models (high voltage)

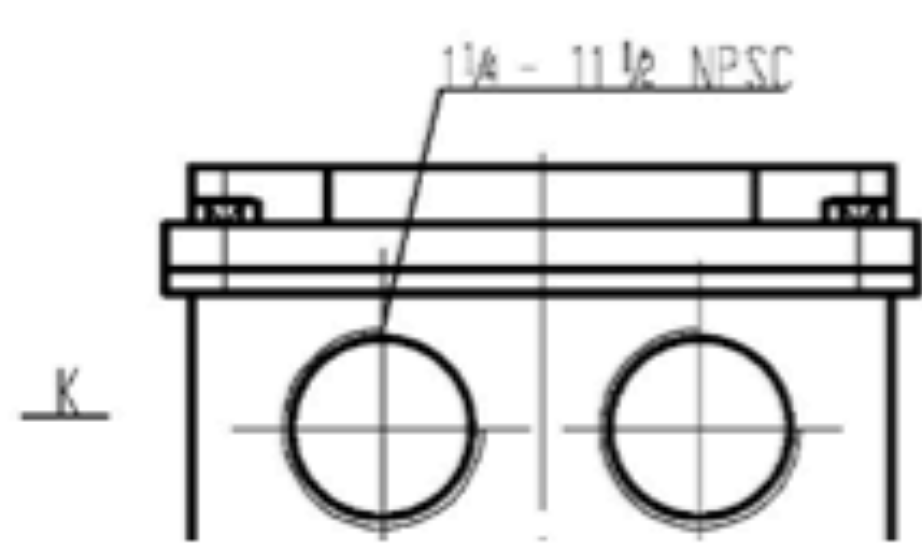
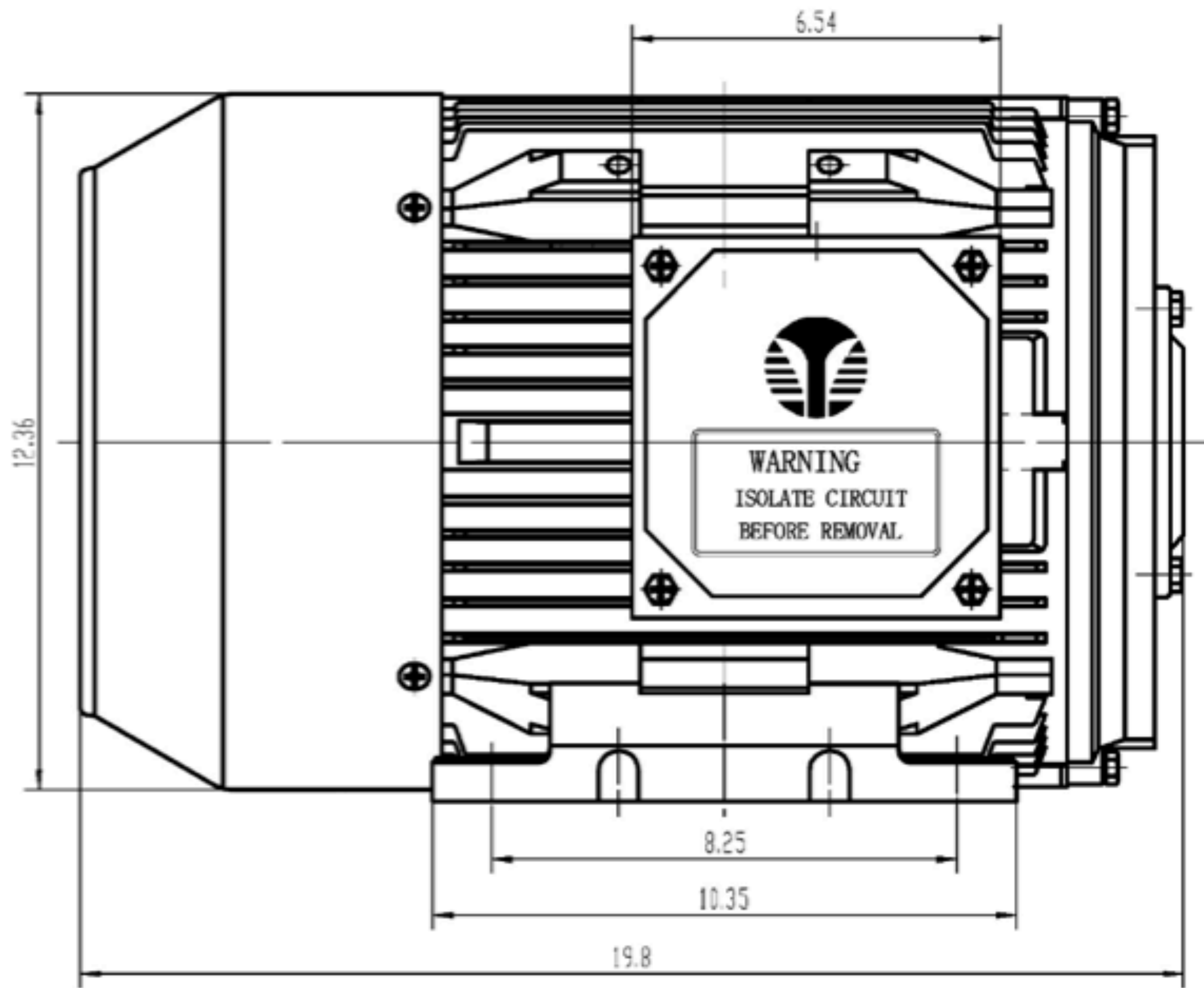
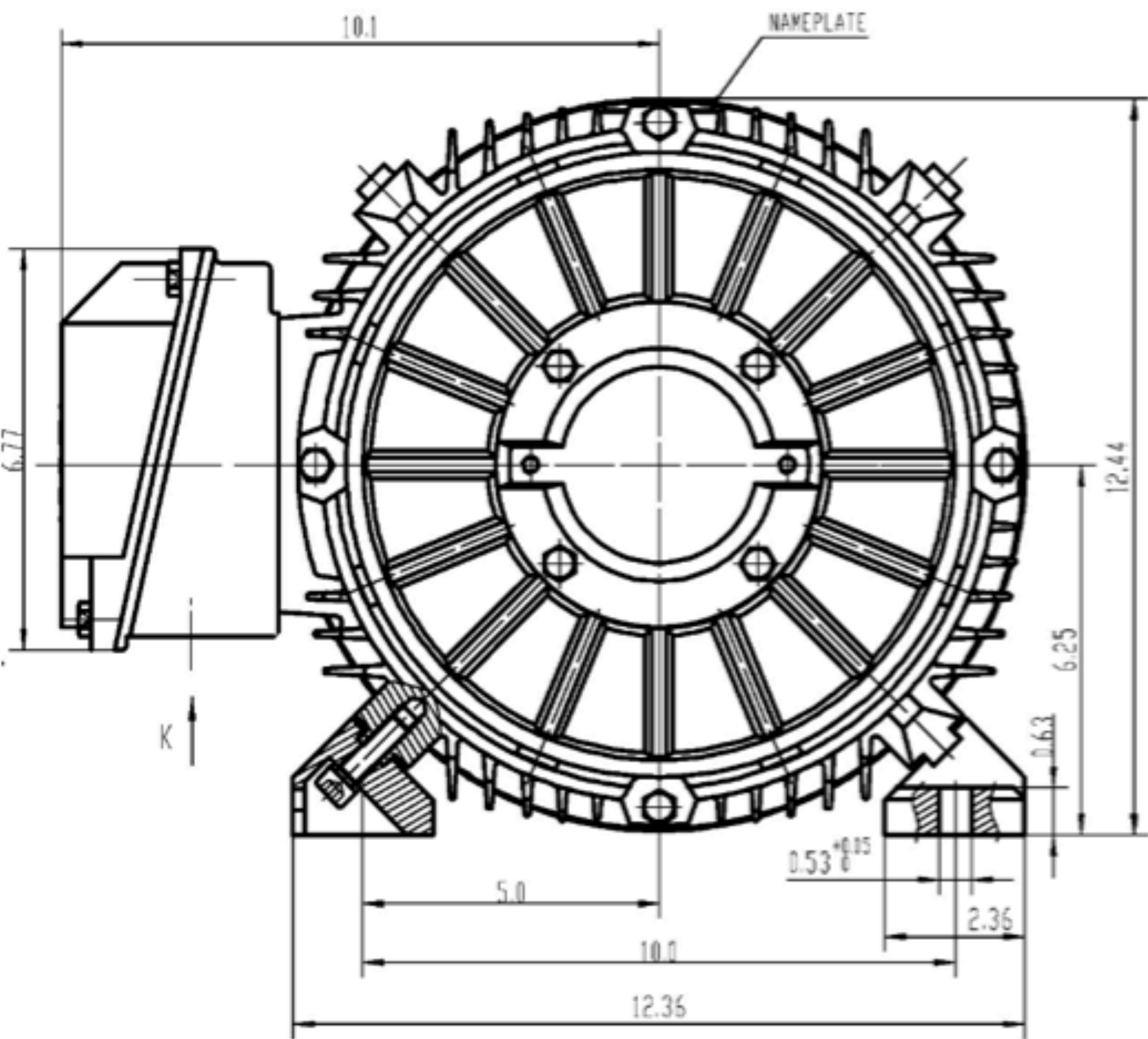

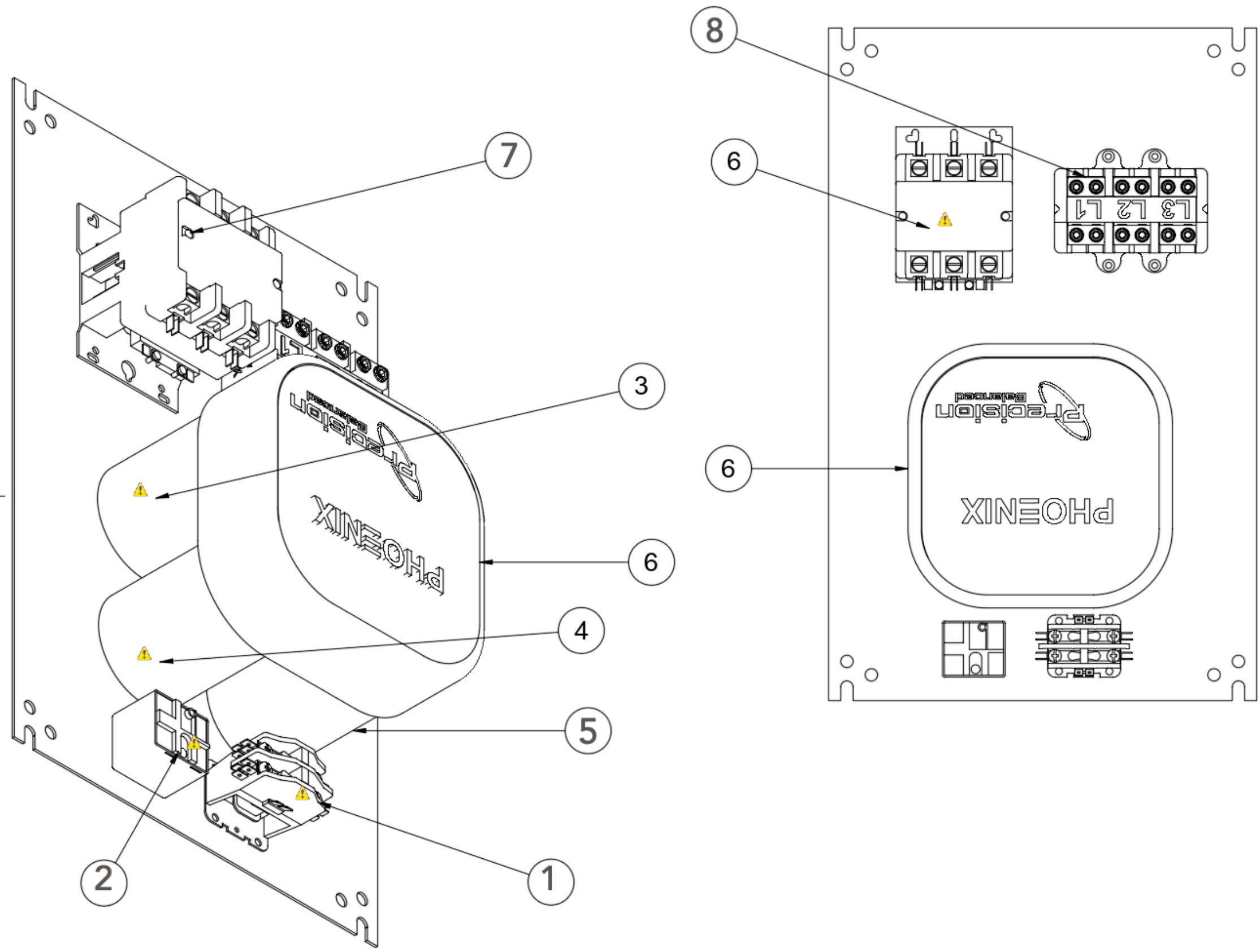

7.5 HP Rotary Phase Converter Components

Item Number	Description (click on the description to visit the link to the item)	Quantity in Model	PRICE	SKU# Click SKU for 3d Viewing
1	Two Pole Contactor - 230 Volts 30-40 Amps	1	28.00	GP2P30A
2	Relay 90-66	1	47.00	GP90-66
3	100 MFD 370V Run Capacitor (SILVER CAP)	2	26.00	
4	630 MFD 220V Start Capacitor (BLACK LARGER CAP)	1	24.14	
5	270-324 MFD 220V Start Capacitor (BLACK SMAL CAP)	1	18.00	
6	Capacitor Holder and Lid	1	115.00	
7	3 Pole Contactor 50-60 AMP 230 Volts	1	52.84	C375C
8	5 HP 3 Pole Power Block	1	45.00	